

# 1.1 Exercises

## ✓ CONCEPT CHECK

1. \_\_\_\_\_ reasoning starts with specific examples or observations and comes to a general conclusion.
2. \_\_\_\_\_ reasoning starts with accepted facts and comes to a specific conclusion.
3. True or False: If every pair in a sequence of terms differs by a multiple of two, then the sequence is an arithmetic sequence.
4. True or False: If a single counterexample to a line of reasoning is found, then the line of reasoning is false.

## 💡 PRACTICE

Identify whether each statement is an example of inductive or deductive reasoning.

5. The sides of all squares are proportional. The three quadrilaterals shown are all squares. Therefore all of their sides are proportional.

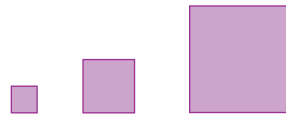

6. If Jessica plays basketball and makes 7 out of every 12 free throws, then she should make 35 out of every 60 free throws.
7. I have an 8:00 a.m. math class on Tuesdays and Thursdays. Each class day, I leave for class in my car at 7:30 a.m. Every day that the drive to campus takes 15 minutes, I arrive to class on time. Therefore, if I leave for class at 7:30 a.m. today and the drive to campus takes 15 minutes, I will be on time.
8. My grade on the first test in Quantitative Reasoning was 85, so I will make a B in the course.
9. If you live in New York, you are a resident of the United States.
10. All squares are rectangles, and all rectangles have four sides. Therefore all squares have four sides.
11. All known planets travel about the sun in elliptical orbits; therefore all planets travel about the sun in elliptical orbits.
12. I spent \$76.54 on groceries last week and \$77.23 on groceries this week, so I will spend less than \$80 on groceries next week.

Find the missing terms of each sequence and determine if the sequence is arithmetic, geometric, or neither. If the sequence is arithmetic, state the common difference; if the sequence is geometric, state the common ratio.

13. 1, 3, 5, 7, \_\_\_\_\_, \_\_\_\_\_, \_\_\_\_\_      14. 1, 5, 9, 13, \_\_\_\_\_, \_\_\_\_\_, \_\_\_\_\_
15. 15, 10, 5, 0, \_\_\_\_\_, \_\_\_\_\_, \_\_\_\_\_      16. 5, 10, 20, 40, \_\_\_\_\_, \_\_\_\_\_, \_\_\_\_\_
17.  $1, \frac{1}{2}, \frac{1}{4}, \frac{1}{8},$  \_\_\_\_\_, \_\_\_\_\_, \_\_\_\_\_      18. 3, 5, 8, 12, 17, \_\_\_\_\_, \_\_\_\_\_, \_\_\_\_\_
19. 10, 100, 1000, 10,000, \_\_\_\_\_, \_\_\_\_\_, \_\_\_\_\_

20. 1, 3, 4, 7, 11, 18,

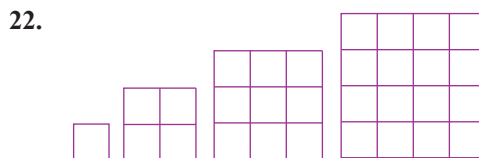
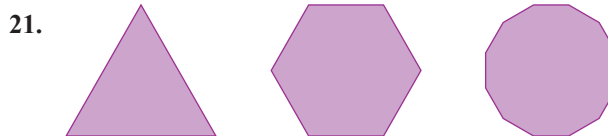

Find a counterexample to each statement.

23. Every Tuesday is an even day of the month.
24. The product of two numbers is always even.
25. If the difference between two numbers is even, then the numbers are both even.
26. If a geometric figure has 4 sides, then the figure is a square.
27. If  $a > b$  and  $a > c$ , then  $b > c$ .
28. If the sum of two numbers is odd, then both numbers are odd.

Use deductive reasoning to choose the correct conclusion for each argument.

29. A grocery store requires a membership card to receive exclusive discounts on groceries. I do not have a store membership card, so I \_\_\_\_.
- a. cannot buy groceries from this store.
  - b. cannot receive the exclusive discounts on groceries from this store.
30. A local animal shelter only allows residents of the county it is located in to adopt animals from the shelter. Julian is a resident of the county the shelter is located in, so Julian \_\_\_\_.
- a. is allowed to adopt an animal from the shelter.
  - b. will adopt a puppy from the shelter.

31. Chicken that is baked in an oven needs to reach an internal temperature of  $165^{\circ}\text{F}$  to be considered fully cooked. A piece of chicken that was baked in the oven has an internal temperature of  $150^{\circ}\text{F}$ , so the piece of chicken \_\_\_\_.
- needs to go back into the oven.
  - is not fully cooked.
32. An album receives gold status after attaining the equivalent of 500,000 sales. A musician's album passed the equivalent of 500,000 sales last week, so the album \_\_\_\_.
- will receive gold status.
  - was well received.

Figurate numbers are numbers that can be represented by any regular geometric figure. (A regular geometric figure is a figure such as a triangle, pentagon, or hexagon where all sides have the same length.)

33. **Triangular Numbers:** Triangular numbers are numbers that can be represented by an equilateral triangle. The first three triangular numbers, 1, 3, and 6, are shown in the figure. Find the next two triangular numbers and represent them with dots in the shape of a triangle.

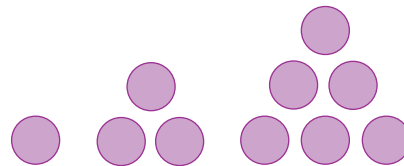

34. **Square Numbers:** Square numbers are numbers that can be represented by a square. We discussed the first five square numbers, 1, 4, 9, 16, and 25, in Examples 2 and 5. Determine the 6th and 7th square numbers and represent them using squares in the shape of a square.

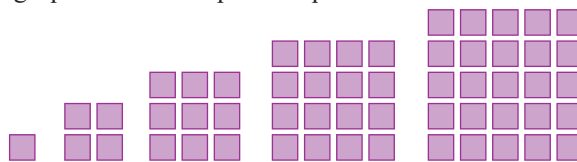

Complete the following Sudoku puzzles.

35.

9	3		5	6	8	1	2	
	2	6	7	1		5	9	3
	5	7	9		3	4	6	
	7	8	1	5	9	3	4	6
6	4	1	3	8		2	5	9
3	9		6	4		7	8	1
5	6	3	4		1	8	7	2
	8		2	3	5	6	1	
4	1	2					3	5

36.

	5				9	3		6
7		9		5	6	8		1
4	6	8	3	7	1			5
	8	7		2	4		5	9
		1		6	3	4	2	8
2	4	6		9		7		3
9	1	4	6	3	7	5	8	2
	2	5	9		8	1	3	7
			5	1	2	9		4

 **WRITING & THINKING**

37. Consider the following pattern.

$$\begin{aligned}
 1 \cdot 12 &= 12 \\
 11 \cdot 12 &= 132 \\
 111 \cdot 12 &= 1332 \\
 1111 \cdot 12 &= 13,332
 \end{aligned}$$

- Based on this pattern, predict the product  $111,111 \cdot 12$ .
- Check your prediction by finding the product.
- What type of reasoning did you employ?

38. Consider the following information.

Multiplication Patterns		
Multiplication	Repeated Addition	Sum
$4 \cdot -2$	$-2 + (-2) + (-2) + (-2)$	-8
$3 \cdot -7$	$-7 + (-7) + (-7)$	-21
$5 \cdot -6$	$-6 + (-6) + (-6) + (-6) + (-6)$	-30

What can you conclude about the sign of the final sum based on multiplication?

## 1.1 PROJECT

### THE LOGIC OF NONOGRAMS

In Section 1.1, you learned about solving problems using logic and you explored a variety of situations and a logic puzzle. Another type of logic puzzle is the nonogram. Nonograms are picture logic puzzles and were created by Non Ishida in 1987. A beginner level 6 x 5 nonogram is shown here.

		1	1	5	1	4	1
5							
1 1 1							
1 1							
1 1							
1 1							

The numbers across the top and along the side indicate how many squares in the columns or rows should be shaded to solve the puzzle. For instance, the 5 in the first row indicates that 5 consecutive squares should be shaded in that row. A space between numbers indicates that there is a gap of *at least* one square between the consecutive shaded squares. For instance, 1 1 indicates that there are two single shaded squares that are separated by at least one empty square. When a nonogram is solved, the solution creates a picture.

There are several ways to approach solving these puzzles, but we'll only cover a few in this project. As you answer the questions, shade any squares you are confident about in the puzzle. If you know a cell will *not* be shaded, you may place an X in that square.

1. While we can start anywhere with solving this puzzle, we'll start with the largest numbers. The third column indicates that 5 consecutive squares should be shaded. Can we guarantee any of the squares in this column will be shaded? Explain your reasoning.
2. The top row indicates that 5 of the 6 squares in the row should be shaded. Since the 5 shaded squares are consecutive, which squares can we guarantee will be shaded? Explain your reasoning.

**Example 1.2.6****Using the Wisdom of the Crowd**

Thirty people were asked to estimate the attendance at an outdoor community concert to the nearest 10. Their estimates are shown in Table 1.2.1. Use the crowd-sourced data to make an estimate of the community concert attendance.

**Table 1.2.1:** Community Concert Attendance Estimates

370	210	310	270	300	260
270	220	270	320	220	330
240	280	230	300	310	200
210	260	240	250	260	300
200	260	310	340	350	290

**Solution**

One method of making an estimate could be to look for the number that was most commonly guessed. However, the wisdom of the crowds says that the average of many estimates is better than a single estimate. So instead of using a single number, we can add all of the estimates together and divide by the number of estimates (30).

The sum of all of the estimates is 8180. Dividing by 30, we have the following.

$$\frac{8180}{30} \approx 272.7$$

Thus, we should estimate that there were approximately 273 people at the community concert.

**Skill Check Answers**

1. Tens (In 2021, there were 13 member countries) 2. Only the estimation for food will change; \$10,450 for 50 guests and \$17,200 for 200 guests 3. Approximately 1.6 billion people

## 1.2 Exercises

**✓ CONCEPT CHECK**

- The values 10 minutes, 10 hours, and 10 days are examples of \_\_\_\_\_.
- Breaking the original question into \_\_\_\_\_ questions can make estimating easier.

3. True or False: Collective intelligence is used to make a more accurate estimate than a single person can make.
4. True or False: When making an estimate, you should never round the values in your calculations.

 **PRACTICE**

Determine the most appropriate order of magnitude for each situation.

5. Student enrollment at a university
6. Number of hamburgers sold worldwide every day
7. Number of flavors of ice cream sold at a local ice cream stand
8. Number of seats in a movie theater

For each estimation, determine which piece of information would be most helpful. Explain your reasoning.

9. Estimate the average gestation period of an Asian elephant.
  - a. The average lifespan of an Asian elephant
  - b. The average weight of newborn Asian elephant
  - c. The average number of elephants born each year
  - d. The average weight of a newborn human
10. Estimate the number of pounds of food served for lunch at a local elementary school each day.
  - a. The average weight of a sandwich
  - b. The average weight of the students
  - c. The number of students who attend the elementary school
  - d. The length of the lunch period
11. Estimate the total number of hours employees of a certain company spend in meetings per year.
  - a. The number of employees who work in the office
  - b. The number of meeting rooms in the office
  - c. The average number of minutes employees spend in the breakroom each day
  - d. The average number of vacation days employees get per year

12. Estimate the length, in minutes, of the audiobook recording of this year's best-selling fiction novel.
  - a. The number of chapters in the novel
  - b. The number of five star reviews the novel received
  - c. The average amount of time it takes to read a single page out loud
  - d. The average length of the audiobook recording of the top five best-selling fiction novels from the past five years

### APPLICATIONS

Estimate the indicated cost.

13. A city is planning a new 3-acre park that will include a playground, a walking trail, and several picnic shelters. Previous parks the city constructed that were similar in amenities averaged 5-acres in size with cost an average of \$900,000 to create. Estimate the cost to create the new park.
14. The Ziegler family plans to create a cement patio in their backyard to use for picnics and grilling. They'd like the patio to be a rectangle that is 18 feet by 20 feet. The previous year, they had a cement patio poured onto the side entrance of their house that was 7 feet by 4 feet, which cost \$250. Estimate the cost of the new backyard patio. Round your answer to the nearest dollar.
15. A family of four plans to go on a seven-night vacation next summer. The previous summer, they went to a similar location for a four-night trip and spent \$4500 total. Estimate the cost of a seven-night vacation.
16. The Wild Flower Foundation is planning their annual Bee the Difference fundraising dinner. The previous dinners had a maximum of 100 seats available and cost on average \$8500 to host (including venue, food, and entertainment). This year, the foundation wants to increase the seating capacity to 175. Estimate the budget they should expect for this year's fundraising dinner.

Break each situation down into smaller parts.

17. You are hosting a birthday party for an 8-year-old child. A total of 20 children plus their parents will attend. You need to estimate the total cost of the party.
18. You are building a new house that needs three bedrooms, two bathrooms, and an attached garage. You need to estimate the total cost to build the house.
19. You and a friend are opening a restaurant. You need to estimate the upfront costs to run the restaurant for 6 months.

20. You are planning a destination wedding and will cover the travel expenses for members of the bridal party. You need to estimate the cost of the wedding.

Solve.

21. A local café sells beverages and pastries and is open for 8 hours each day. On average, customers spend \$6.73 per order. The café averages 24 orders per hour.
- Estimate the amount of money made by the café in one day.
  - Estimate the amount of money made by the café in one week.
22. A new video streaming service claims to have over 700,000 hours of video available for streaming. Each day, an average of 47,882 subscribers use the streaming service for approximately 126 minutes each.
- Estimate the number of hours of video that is streamed each day.
  - Estimate the number of hours of video that is streamed each month.
23. A local food bank takes donations of nonperishable foods every day of the year. The average donation weighs 6.25 pounds, and the food bank receives approximately 32 donations per day.
- Estimate how many pounds of donated food the food bank receives per month.
  - Estimate how many pounds of donated food the food bank receives per year.
24. A taco truck is open for business during a 4-hour window each day. They fulfill an average of 46 orders per hour and each order has an average of 12 tacos.
- Estimate the number of tacos that are served each day.
  - Estimate the number of tacos that are served each month.
25. A farmer is estimating his expected crop yield for the season. He has a farm that is 250 acres, and he planted corn on 100 acres. He planted 31,000 seeds per acre and expects 95% of the seeds to germinate and grow into full stalks. Based on previous years, the farmer expects an average of one ear of corn per stalk. Estimate the number of ears of corn per acre and then estimate the expected corn crop yield for the season.
26. A local news network is estimating the number of people attending a parade based on aerial footage. A single block of the parade route is determined to hold 173 people. The parade route is 24 blocks long. Estimate the number of people who attended the parade.

27. A bakery held a contest for people to guess how many sprinkles are on the top of a cake. The winner would receive a \$50 gift card. You determine that the cake is a half-sheet, meaning it measures 18-by-13 inches. You count that there are 31 sprinkles on a section of cake that is approximately one square inch in area. Based on this information, how many sprinkles would you guess are on the cake?
28. An editor is asked to give an estimate for the cost to edit a chapter of a book. To create the estimate, she needs to first determine the number of words in the chapter. The chapter is 56 pages long and the first two pages of the chapter each have an average of 472 words. How many words should she estimate are in the chapter?
29. Twenty people are asked to estimate the number of tacos sold by a local taco stand per day, rounded to the nearest ten. Their estimates are shown in the following table. Use the crowd-sourced data to make an estimate of the number of tacos sold per day by the local taco stand.

840	890	840	810	870
730	810	720	790	770
870	870	800	830	760
760	830	820	780	800

30. Twenty-five people are asked to estimate the number of people who attend a local corn festival per day, rounded to the nearest ten. Their estimates are shown in the following table. Use the crowd-sourced data to make an estimate of the number of corn-fest attendees per day.

810	960	870	1170	920
870	1030	860	1000	890
1160	920	1080	1060	1150
1070	1010	980	1120	820
1100	890	860	1100	1190

31. A contest is held to guess the number of jelly beans in a jar. The guesses of 20 people are provided in the following table. Use the crowd-sourced data to make an estimate of the total number of jelly beans in the jar.

282	312	328	331	311
373	341	328	284	308
277	353	277	389	275
385	280	286	374	277

32. Twenty-five college students are asked to estimate the number of minutes they think students spend on social media per day. Their estimates are shown in the following table. Use the crowd-sourced data to estimate the total number of minutes students spend on social media per day.

103	162	168	167	124
151	174	176	218	116
148	194	158	181	170
182	91	144	156	154
204	191	166	91	202

33. Suppose your project needs one project manager, two user-experience professionals, and three app developers. The rates for each of these team members are as follows.

Project manager: \$118.50 per hour

User-experience professionals: \$88 per hour

App developers: \$125 per hour

The project requires the project manager for 100 hours, each user experience professional for 50 hours, and each app developer for 100 hours. Estimate the total cost of the project.

34. In his first week at college, Chase spent the following.

Entertainment: \$28

Apparel: \$24

Travel (gas): \$18

If there are 12 weeks in the semester, estimate the amount of money Chase will spend on these things throughout the semester.

35. Trying to prepare a budget for his first few months in his new place, Darren has done research and found the following average costs per month: health insurance \$183, phone/internet/cable \$140, electric \$179. If Darren will be earning \$1700 per month, estimate the amount of money he will have after paying these bills each month.
36. Jane had a dream to complete an Ironman triathlon. The race consists of a 2.4-mile swim, a 112-mile bike ride, and a marathon run of 26.2 miles. In training, Jane can swim at an average pace of 1.9 mph. She rides her bike at an average of 20.8 mph, and runs at 4.1 mph. Estimate how long it will take her to complete the Ironman triathlon.
37. Because Elias is self-employed, he is advised to pay quarterly estimated federal tax payments since his income tax withholding will not fully cover next year's tax liability. Online advice instructs him to determine last year's tax, minus any withholding, and divide by four. Estimate the quarterly taxes Elias should pay if his total tax from last year was \$23,741 and his total withholding was \$7500.

38. Amelia is planning a road trip from Nashville, Tennessee, to Washington, D.C. The distance from Nashville to Washington is 651 miles and will take about 36 gallons of gas to complete.
- If gas costs an average of \$3.745, estimate the fuel cost for the one-way trip.
  - Use your answer for part **a.** to estimate the total cost of fuel for the round trip.
39. Debbie needs to purchase some printer paper and USB jump drives for the department where she works. Each ream of paper costs \$4.55 and each pack of 4 jump drives costs \$27.85. She needs nine reams of paper and six packages of jump drives. Approximate to the nearest dollar the amount of money Debbie will spend to make the purchase.
40. Marcel has decided to paint his new apartment. He estimates the cost of paint will be \$385. Which estimate should Marcel use for the job so that his budget includes a contingency factor of 8% in addition to the cost of paint?
- \$38
  - \$432
  - \$395
  - \$800

**WRITING & THINKING**

41. Three students estimate the product  $57 \cdot 159$ . Explain which of the following estimations will be the most precise and why:  $50 \cdot 100$ ,  $60 \cdot 200$ ,  $60 \cdot 160$ .

## 1.2 PROJECT

### ESTIMATING TUNERS AND TOILETS

The physicist Enrico Fermi once asked a class of students to estimate the number of piano tuners in Chicago. We'll walk through the same estimating process that he used to solve this problem. For each step, explain your thought process for the estimate or calculation. Do not look up any values during this project. Use your reasoning skills to estimate at each step along the way.

- Suppose the city of Chicago has approximately 3 million people living in it. From this value, estimate how many households are in Chicago. (**Hint:** First estimate how many people are in a household.)
- Estimate how many households in Chicago own a piano. Using this estimate, determine how many pianos are likely to exist in Chicago.
- Next, estimate how often the average piano owner has their piano tuned per year.
- Now, consider how many pianos a single piano tuner can tune per year. Assume that it takes an hour to an hour and a half to tune a piano. (**Hint:** Would the piano tuner work every day of the year? How much travel time might the tuner need between appointments?)

## 1.3 Exercises

### ✓ CONCEPT CHECK

1. True or False: When understanding a problem, it can be helpful to restate the problem using different phrasing.
2. True or False: When devising a plan to solve a problem, it can be helpful to look for patterns in the given data.
3. True or False: When carrying out the plan to solve a problem, if the plan you devised doesn't work, it's not worth creating a new plan and trying again.
4. True or False: It is useful to look back over your problem-solving process to help ensure that the conclusion you reached makes sense for the situation.

### 👤 APPLICATIONS

5. A child snuck out of the house one evening and bought a bag of candy. His older sister caught him sneaking back into the house and said that if he handed over one-fourth of the candy, she wouldn't tell their parents. So he gave her the candy. His younger sister saw him sneaking back to his room and said if he gave her twenty percent of the candy, she wouldn't tell their parents, so he gave her some candy. His younger brother found him hiding the candy in the room they shared and said if he gave him half of the candy, he wouldn't tell their parents. So he gave him some candy. After the series of negotiations, the child had 6 pieces of candy to hide. How many pieces of candy were in the bag when he returned home?
6. An employee baked a fresh batch of cookies and brought them to work the next day. She told a coworker that she'd give him one-fourth of the cookies plus three if he went to a meeting in her place. He accepted. She then told another coworker that she'd give her one-third of the remaining cookies plus two if she created a PowerPoint presentation for a meeting later in the week. She accepted. The employee finally told another coworker that she'd give him three-fourths of the remaining cookies if he researched a new product line for her. He accepted. After these work negotiations, she had three cookies left. How many cookies did she take to work with her that day?
7. Complete the following magic square using the numbers 1 through 16, where the sum of every row, column, and diagonal is the same.

16	2		
5	11		8
	7	6	
4	14		1

8. Arrange the numbers 1, 2, 3, 4, 5, and 6 in the given circles so that the sum of the numbers of each side is equal to 9.

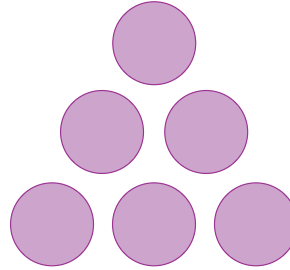

9. Arrange the numbers 1, 2, 3, 4, 5, and 6 in the given circles so that the sum of the numbers of each side is equal to 10.

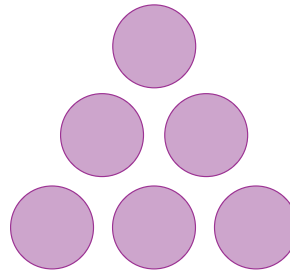

10. Place the digits 1, 2, 3, 4, and 5 in the circles so that the sums across (horizontally) and down (vertically) are equal.

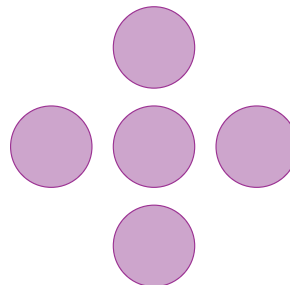

11. Arrange the numbers 1, 2, 3, 4, 5, 6, 7, 8, and 9 in the given circles so that the sum of the numbers of each side is equal to 19.

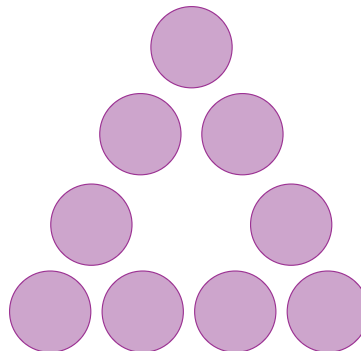

12. Arrange the numbers 1, 2, 3, 4, 5, 6, 7, 8, and 9 in the given circles so that the sum of the numbers of each side is equal to 23.

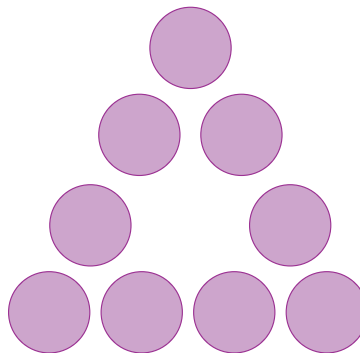

13. Place the numbers 1, 2, 3, 4, 5, 6, 7, 8, and 9 in the magic square so that the sum of the numbers in each row, column, and diagonal is equal to 15.

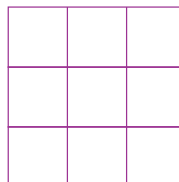

14. Use the digits 0, 1, 2, 3, 4, 5, 6, 7, and 8 to create another magic square so that the sum of the numbers in each row, column and diagonal is equal to 12.

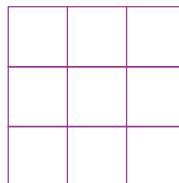

15. A rectangle has an area of 72 square inches. Its length and width are whole numbers.
- What are the possible dimensions of the rectangle?
  - Which of those dimensions yield a rectangle with the smallest perimeter?
16. Carlos is placing an order online for curbside pickup and notices a promotion that if he spends \$75 on his order (before tax), he will receive a \$20 gift card for a future purchase. He needs to purchase a pack of LED lightbulbs for \$32.99, a bottle of laundry detergent for \$15.99, a throw blanket for \$24.99, and a travel coffee mug for \$17.99. Can he purchase three of the four items with this online order and use the gift card to purchase the remaining item? If so, which three of items should he purchase?
17. Marcus is considering which presents to buy for his son's birthday. He wants to limit the overall cost to \$100, including tax, so he is aiming for the gift total to be no more than \$90 before taxes. His son has the following toys on his wish list: fire station playset (\$19.69), dinosaur expedition playset (\$22.99), toy soldiers set (\$35.99), construction truck set (\$31.99), miniature racetrack with cars (\$9.99), and a medieval castle (\$85.89). If Marcus wants to purchase as many gifts as possible and stay within the set budget, which toys should he buy?

18. Emmet has five bills due this month: water & sewer (\$95.50), internet (\$75.45), electric (\$115.79), gas (\$63.98), and phone (\$112.79). He currently only has \$350 to put towards bills. Each company imposes a \$20 late fee if the bill is not paid on time. It is possible for Emmet to pay four of the bills in order to incur only one late fee? If so, which bills should he pay?
19. Sofia is planning a weekend trip and wants to limit her spending to \$500, not including travel expenses. She'll stay for two nights at a hotel that costs \$115 per night (including taxes and fees), and she estimates her meals will cost a total of \$120. The activities in the area that Sofia is considering include an aquarium (\$58), an art museum (\$25), a zipline tour (\$75), and a wine tasting tour (\$65). Can Sofia pick three of the activities and stay within her budget? If so, which three activities?
20. Azra has four assignments that are due by the end of the week and only has 20 hours to spend working on them. Any late assignments will incur a 10% grade deduction. She estimates that her math assignment will take 4 hours, her literature assignment will take 7.5 hours, her sociology assignment will take 8 hours, and her business ethics assignment will take 5 hours. All courses are equally important to her. Can Azra complete three of the four assignments and only incur one late penalty? If so, which three assignments?
21. Find the sum of the whole numbers from 1 to 900.
22. Find the sum of the even numbers from 1 to 500.
23. Find the sum of the odd numbers from 1 to 700.
24. The Alpha Zeta Math Club is having a pizza party. The president of the club decides to have fun cutting the pizza and challenges the members to cut a pizza into 11 pieces with only 4 straight cuts. Show a way that this could be done.
25. There are eight teams in the intramural basketball league. Each of the teams will play each other five times. What is the total number of games played in the league?
26. A local bowling league consists of seven teams and each team plays each other team three times. What is the total number of games played in the league?
27. At a birthday party, a child was permitted to cut his own cake to serve to the guests. The cake was round, and the child cut it into 16 pieces using only 5 cuts. (Each cut was vertical through the top of the cake.) Draw a diagram of how this was possible.
28. A farmer looks over a field and sees 37 heads and 98 feet. Some are goats, some are chickens. How many of each are there?
29. Jessica needs to mail a USB drive to her friend. She uses a combination of 41-cent stamps and 8-cent stamps to pay \$1.71 in postage. How many of each stamp did Jessica use?

30. While inspecting tanks at an aquarium, a keeper counts 148 legs and 16 heads in a tank that holds octopuses and crabs, which have 8 and 10 legs, respectively. How many of each creature are there?
31. Ruth is sending a care package to her granddaughter, Sarah, who is in college. The care package contains two of Sarah's favorite cookies: fudge swirls, which come in packs of 12, and extra chocolate chunk, which come in packs of 5. The care package contains a total of 107 cookies. How many packs of each cookie type were included?
32. The product of two whole numbers is 196 and their sum is 35. What are the two numbers?
33. The product of two whole numbers is 902 and their sum is 63. What are the two numbers?
34. Twice the difference of a number and 1 is 4 more than that number. Find the number.
35. A number is multiplied by 8, and that product is added to 3. The sum is equal to the product of 5 and 7. Find the number.

 **WRITING & THINKING**

36. One of the most interesting and useful patterns in all of mathematics is called Pascal's triangle, as shown. It is named after the French mathematician Blaise Pascal (1623–1662) who showed that these numbers play an important role in the theory of probability.

$$\begin{array}{c}
 1 \\
 1 \ 1 \\
 1 \ 2 \ 1 \\
 1 \ 3 \ 3 \ 1 \\
 1 \ 4 \ 6 \ 4 \ 1 \\
 1 \ 5 \ 10 \ 10 \ 5 \ 1 \\
 1 \ 6 \ 15 \ 20 \ 15 \ 6 \ 1
 \end{array}$$

- a. Copy the array and fill in the next three rows of numbers using the pattern(s) that you notice.
- b. Compute the sum of the elements in each row of Pascal's triangle for the first 6 rows.
- c. Look for a pattern in the sums of the first 6 rows. See if you can predict the sum of the elements for row 7, then check by adding. Do the same for rows 8 and 9. State the general rule for the sum of the elements in words.

**Solution**

Since  $A$  consists of American adults who have at least one tattoo, the complement of  $A$  consists of American adults who do *not* have at least one tattoo. We know that *at least one* means greater than or equal to one, so *does not have at least one* implies has less than one or simply no tattoos at all. We can write the complement of  $A$  as follows.

$$A' = \{x \mid x \in U \text{ and } x \text{ has no tattoos}\}$$

This could also be written as  $A' = \{x \mid x \text{ is in } U \text{ and } x \text{ has no tattoos}\}$ . Note that based on the poll data,  $A'$  represents approximately 70% of American adults.

$B$  is the set of American adults with exactly two tattoos. The complement of  $B$  includes all of the elements in our universal set that are not contained in  $B$ . This translates to American adults that do *not* have exactly two tattoos. The complement of  $B$  therefore contains adults with 0 tattoos, 1 tattoo, or 3 or more tattoos. We can write the complement of  $B$  in either of the following ways.

$$B' = \{x \mid x \text{ is an American adult who does not have exactly two tattoos}\}$$

Or

$$B' = \{x \mid x \in U \text{ and } x \text{ has either 0 tattoos, 1 tattoo, or 3 or more tattoos}\}$$

**✓ Skill Check 2.1.4**

Let

$U = \{x \mid x \text{ is a book published in the US in 2021}\}$

$A = \{x \mid x \in U \text{ and you read } x \text{ as an e-book}\}$ .

1. Find  $A'$ .
2. Is it possible for you to have read a book in  $A'$ ?

**Skill Check Answers**

1.  $|W| = 4$ ,  $|Y| = 5$ ;  $W$  and  $Y$  are neither equal nor equivalent.
2. Roster notation:  $J = \{1, 2, 3, 4, 5, 6, 7, 8, 9\}$ ; Set-builder notation: possible answers include  $J = \{x \mid x \text{ is a natural number less than } 10\}$  and  $J = \{x \mid x \in \mathbb{N}, x < 10\}$
3. Yes,  $Y = \emptyset$ .
4.  $A' = \{x \mid x \in U \text{ and you did not read } x \text{ as an e-book}\}$ ; Yes, but not as an e-book; perhaps as a printed or audio book.

## 2.1 Exercises

**✓ CONCEPT CHECK**

Determine whether each statement is true or false. If the statement is false, explain why.

1. It is always possible to list every element of a set using roster notation.
2.  $\emptyset \sim \{0\}$
3. Let  $U = \{\text{set of all students enrolled at Xavier University}\}$  and  $A = \{x \mid x \in U \text{ and } x \text{ is a student with less than 30 earned credit hours}\}$ . Then  $A' = \{x \mid x \in U \text{ and } x \text{ is a student with at least 30 earned credit hours}\}$ .
4.  $0 \in \emptyset$

5.  $x \in \{x, y, z\}$
6.  $\{x\} \in \{x, y, z\}$
7.  $|\emptyset| = 0$
8. Let  $Y = \{\text{Tim, Emilia, Aleesa, Whit}\}$ , then  $|Y| = 4$ .
9. Let  $A = \{\text{Sounds, Angels, Ravens, Titans}\}$  and  $B = \{201, 38, 46, 23\}$ , then  $A \sim B$ .

 PRACTICE

Write each set using roster notation.

10.  $A$  is the set of months of the year that have exactly 30 days.
11.  $B$  is the set of states whose names begin with the letter N.
12.  $C$  is the set of positive numbers smaller than 100 that have 2 digits that are the same.
13.  $D$  is the set of last names of people who teach this course at your university.
14.  $E$  is the set of planets in our solar system.
15.  $F$  is the set of weekdays.
16.  $A = \{x \mid x \text{ is an odd number and } 20 < x < 30\}$
17.  $B = \{x \mid x \leq 15 \text{ and } x \text{ is a positive multiple of } 3\}$
18.  $C = \{x \mid 2x = 4\}$
19.  $D = \{x \mid x \text{ is a state that shares a common border with Colorado}\}$

Determine the cardinal number of each set.

20.  $W = \{3, 4, 5, 6, 7, 8, 9, 10, 0\}$
21.  $X = \{x \mid x \text{ is a positive integer and } x \leq 10\}$
22. The empty set
23.  $Y = \{x \mid x \text{ is a United States president, past or present}\}$

Determine if the given pairs of sets are equal, equivalent, or neither.

24.  $A = \{1, 2, 3, 5, 7, 11, 13, 17, 19\}$

$B = \{2, 4, 6, 10, 14, 22, 26, 34, 38\}$

25.  $C = \{\text{banana, tomato, grape, eggplant, watermelon, pumpkin}\}$

$D = \{\text{blackberry, raspberry, strawberry, sloeberry}\}$

26.  $E = \{\text{c, o, n, s, t, r, u, e}\}$

$F = \{\text{r, e, c, o, u, n, t, s}\}$

27.  $G = \{\text{r, e, s, c, u, e, d}\}$

$H = \{\text{s, e, c, u, r, e}\}$

Write each set using set-builder notation.

28. Let  $G$  be the set of whole numbers less than five.

29. Let  $H$  be the set of natural numbers less than or equal to 50.

30. Let  $U$  be the set of all the states in the United States of America and  $J$  be the set of all states that border an ocean.

31. Let  $U$  be the set of all students enrolled at a public school of higher education and  $K$  be the set of all collegiate athletes.

32.  $M = \{2, 3, 4, 5, 6, 7\}$

33.  $Q = \{3, 6, 9, 12, 15, 18, 21, \dots\}$

34.  $U = \{-10, -8, -6, -4, -2\}$

35.  $P = \{1, 2, 4, 9, 16, 25, 36, \dots\}$

Determine whether each set is the empty set.

36.  $W = \{x \mid x \text{ is a positive integer less than } 0\}$

37. The set  $X$  is the set of months that have fewer than 30 days.

38.  $Y = \{\emptyset\}$

39.  $Z = \{x \mid x \text{ is divisible by } 10\}$

Use the set  $A = \{\text{b, a, s, k, e, t}\}$  to solve each problem.

40. Find  $|A|$ .

41. If  $U = \{\text{a, b, c, d, } \dots, \text{x, y, z}\}$ , find  $A'$ .

42. If  $U = \{\text{a, b, c, d, } \dots, \text{x, y, z}\}$ , find  $|A'|$ .

43. If  $U = \{\text{a, b, c, d, } \dots, \text{x, y, z, A, B, C, D, } \dots, \text{X, Y, Z}\}$ , find  $A'$ .

44. If  $U = \{a, b, c, d, \dots, x, y, z, A, B, C, D, \dots, X, Y, Z\}$ , find  $|A'|$ .

Use the set  $B = \{1, 2, 3, 4\}$  to solve each problem

45. Find  $|B|$ .

46. If  $U = \{0, 1, 2, 3, 4, 5, 6, 7, 8, 9\}$ , find  $B'$ .

47. If  $U = \{0, 1, 2, 3, 4, 5, 6, 7, 8, 9\}$ , find  $|B'|$ .

48. If  $U = \{-9, -8, -7, -6, \dots, 6, 7, 8, 9\}$ , find  $B'$ .

49. If  $U = \{-9, -8, -7, -6, \dots, 6, 7, 8, 9\}$ , find  $|B'|$ .

Use the given sets to answer each question.

$P = \{\text{lasagna, rotini, orzo, tortellini, penne}\}$

$Q = \{x \mid x \text{ is a pasta shape}\}$

$R = \{\text{penne, tortellini, orzo, rotini, lasagna}\}$

$S = \{\text{marinara, pesto, alfredo, Bolognese, carbonara}\}$

50. Is  $P = Q$ ? Why or why not?

51. Is  $P = R$ ? Why or why not?

52. Is  $P = S$ ? Why or why not?

53. Are any of  $P$ ,  $Q$ ,  $R$ , and  $S$  equivalent? Explain.

Use the given sets to answer each question.

$A = \{\text{Business, Physics, Psychology, Kinesiology, Graphic Design, History}\}$

$B = \{\text{History, Graphic Design, Kinesiology, Physics, Business}\}$

$C = \{\text{Art History, Education, Nursing, Biology, Statistics}\}$

$D = \{x \mid x \text{ is a university major}\}$

54. Is  $A = B$ ? Why or why not?

55. Is  $B = C$ ? Why or why not?

56. Is  $A = D$ ? Why or why not?

57. Are any of  $A$ ,  $B$ ,  $C$ , and  $D$  equivalent? Explain.

### WRITING & THINKING

58. Give an example of a set that cannot be represented using roster notation. Explain your reasoning.

Dr. Williams could put together is the number of subsets of the 16 items on the buffet. We can use the formula for the number of subsets to determine how many different meals he could make. Using the formula for the number of subsets, we have the following.

$$\text{Number of Plates} = 2^{16} = 65,536.$$

This means that if Dr. Williams ate at the buffet once a day every day, he could eat for almost 180 years without duplicating a meal. Certainly, it would seem the sign is not misleading.

### Skill Check Answers

1. 1, 2, 3

2.

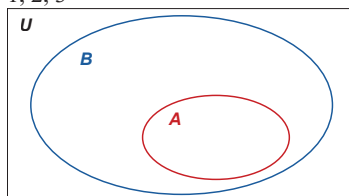

3.  $\emptyset, \{a\}, \{b\}, \{c\}, \{d\}, \{a, b\}, \{a, c\}, \{a, d\}, \{b, c\}, \{b, d\}, \{c, d\}, \{a, b, c\}, \{a, b, d\}, \{a, c, d\}, \{b, c, d\}$

## 2.2 Exercises

### ✓ CONCEPT CHECK

1. A \_\_\_\_\_ is a visualization of the relationships that exist between sets.
2. If set  $A$  is a subset of set  $B$ , that means every element of set \_\_\_\_\_ is also an element of set \_\_\_\_\_.
3. In a proper subset, there is at least one \_\_\_\_\_ of the set that is not in the subset.
4. True or False: The empty set is a subset of every set.
5. True or False: If set  $X$  is a subset of set  $Y$  and set  $X$  is also equivalent to set  $Y$ , then set  $X$  is not a proper subset of set  $Y$ .

 PRACTICE

Use the Venn diagram to solve each problem.

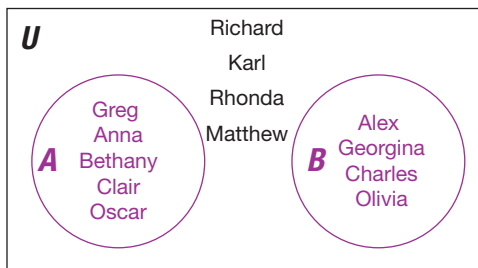

6. List  $A$  and  $B$  using roster notation.
7. Find  $A'$ .
8. List  $U$  using roster notation.

The following Venn diagram represents the sets  $M$ ,  $N$ , and  $P$  within the universal set  $U = \{x \mid x \text{ is a positive integer and } x \leq 25\}$ . The sets are defined as  $M = \{x \mid x \text{ is a multiple of 5}\}$ ,  $N = \{x \mid x \text{ is divisible by 12}\}$ , and  $P = \{x \mid x \text{ is a perfect square}\}$ . Use the diagram to answer the following questions.

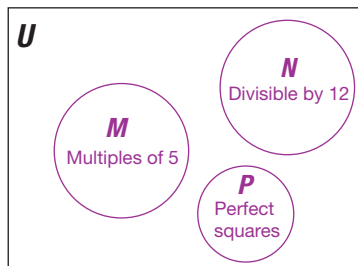

9. List the elements of sets  $M$ ,  $N$ , and  $P$  in roster notation.
10. Find  $|M|$ ,  $|N|$ , and  $|P|$ .
11. Find  $M'$ .
12. Is  $M = P$ ? Is  $M \sim P$ ? Explain your answers.

The following Venn diagram represents the sets  $Q$ ,  $R$ , and  $S$  within the universal set  $U = \{x \mid x \text{ is a positive integer and } x < 20\}$ . The sets are defined as  $Q = \{x \mid x \text{ is an even number}\}$ ,  $R = \{x \mid x \text{ is divisible by } 2\}$ , and  $S = \{x \mid x \text{ is a multiple of } 0\}$ . Use the diagram to answer the following questions.

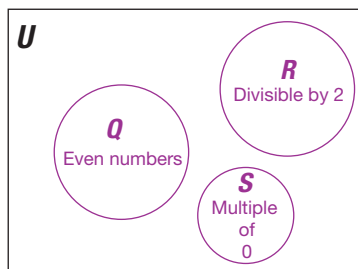

13. List the elements of sets  $Q$ ,  $R$ , and  $S$  in roster notation.
14. Find  $|Q|$ ,  $|R|$ , and  $|S|$ .
15. Find  $R'$ .
16. Is  $Q = R$ ? Is  $Q \sim R$ ? Explain your answers.
17. Let  $A = \{0, 1, 2, 3, 4, 5\}$  and  $B = \{5, 4, 3, 2, 1\}$ . Is  $B \subseteq A$ ?
18. Let  $A = \{\{a, b\}, c, d, e\}$  and  $B = \{a, b, c\}$ . Is  $B \subseteq A$ ?
19. The set  $B$  contains the names of three of the most expensive paintings ever sold. If  $B = \{\textit{The Card Players}$  by Cézanne, *No. 5 1948* by Pollock, *Woman III* by de Kooning}, list all the subsets of  $B$ .
20. Given  $A = \{x \mid x \in \text{positive whole numbers less than } 100\}$  and  $B = \{x \mid x \in \text{even non-negative integers less than } 100\}$ , is either set a subset of the other? Explain.

List all subsets of the given set.

21.  $L = \{\text{lemon, lime}\}$
22.  $T = \{1, 2, 3\}$
23.  $Q = \{\text{four, vier, cuatro, quatre}\}$
24.  $W = \{\text{one}\}$

Draw each Venn diagram.

25. Let  $U$  consist of all artists. Draw a Venn diagram to represent the two sets violinist and musicians.
26. Let  $U$  consist of all four legged animals. Draw a Venn diagram to represent the two sets male dogs and female dogs.

27. Draw a separate Venn diagram to illustrate each of the following.
- $W \subseteq Y$
  - $Y \subseteq W$
28. Let  $U = \{x \mid x \in \mathbb{R}\}$ ,  $W = \{x \mid x \text{ is a counting number less than } 20\}$ , and  $Y = \{2, 4, 6, 8, 10\}$ . Draw a Venn diagram to represent  $U$ ,  $W$ , and  $Y$  with the elements in the proper regions.
29. Let  $U = \{\text{Red, Orange, Yellow, Green, Blue, Indigo, Violet}\}$ ,  $A = \{\text{Green, Orange, Yellow}\}$ , and  $B = \{\text{Indigo, Violet}\}$ . Draw a Venn diagram to represent  $U$ ,  $A$ , and  $B$  with the elements in the proper regions.

Solve.

30. Let  $P = \{\text{baklava, cannoli, eclair, polvorones, strudel}\}$ . Determine if the following sets are proper subsets of  $P$ .
- $A = \{\text{baklava, cannoli, eclair}\}$
  - $B = \{ \}$
  - $C = \{\text{baklava, strudel, cannoli, eclair, polvorones}\}$
  - $D = \{\text{polvorones, pie, paxlava}\}$
31. Let  $M = \{\text{c, a, l, i, p, e, r}\}$ . Determine if the following sets are proper subsets of  $M$ .
- $A = \{\text{r, e, p, l, i, c, a}\}$
  - $B = \{\text{r, e, c, a, p}\}$
  - $C = \{\text{l, e, a, p}\}$
  - $D = \{\text{r, a, i, s, e}\}$

List all proper subsets of the given set.

32. The set  $C$  contains the names of the top three grossing films of all time as of Summer 2014,  $C = \{\text{Avatar, Titanic, Marvel's The Avengers}\}$ .
33.  $F = \{2, 4, 6\}$
34.  $P = \{\text{pen, pencil}\}$
35.  $W = \{\text{cloudy, rainy, sunny}\}$
36.  $T = \{10, 20, 30, 40\}$
37.  $L = \{0\}$

Solve.

38.  $W$  contains The New York Times' top five fiction books for 2013. If  $W = \{\text{The Goldfinch, Americanah, The Flamethrowers, Life After Life, Tenth of December}\}$ , how many subsets does  $W$  contain? How many proper subsets?

39. Given that  $B = \{\zeta, \mathfrak{H}, \heartsuit, \omin�, \odot, \mathfrak{A}, \mathfrak{B}, \odot\}$ . How many subsets does  $B$  have? How many proper subsets does  $B$  have?
40. Determine the number of subsets contained in  $Y$  if  $Y = \{x \mid x \text{ is an odd positive integer and } x < 25\}$ .
41. A set has 32 subsets. How many elements are in the set?
42. A set has 127 proper subsets. How many elements are in the set?
43. The national fast food chain Wendy's advertises that there are 256 ways to personalize a Wendy's hamburger. How many condiments must Wendy's carry for their customer to have this many choices?

### 🔑 APPLICATIONS

Every year, thousands of deaths happen as the result of a drunk driver causing a car crash. The number of deaths varies state to state, with higher numbers occurring in states with higher populations. In 2019, the five states with the highest number of deaths due to drunk drivers were California, Florida, Georgia, North Carolina, and Texas. Let

$$U = \{x \mid x \in \text{death as the result of drunk driving in the United States}\}$$

$$C = \{x \mid x \in \text{death as the result of drunk driving in California}\}$$

$$F = \{x \mid x \in \text{death as the result of drunk driving in Florida}\}$$

$$G = \{x \mid x \in \text{death as the result of drunk driving in Georgia}\}$$

$$N = \{x \mid x \in \text{death as the result of drunk driving in North Carolina}\}$$

$$T = \{x \mid x \in \text{death as the result of drunk driving in Texas}\}$$

The following Venn diagram depicts the five states with the most deaths that occur as the result of drunk driving in 2019 within the universal set of all deaths that occurred as a result of drunk driving in the United States. The cardinal number for each set is shown inside the appropriate circle.

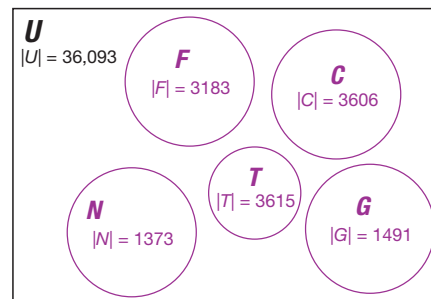

44. Which state had the most deaths caused by drunk driving in 2019?
45. Which state had the second highest number of deaths caused by drunk driving in 2019?

46. How many total deaths caused by drunk driving happened in these five states in 2019?
47. How many deaths caused by drunk driving happened in the United States in 2019 but did not happen in one of these five states?

 **WRITING & THINKING**

48. Explain why  $\text{Red} \not\subset \{\text{Red, Blue, Green}\}$ .
49. A new keyless car security system allows the owner to create a “handprint” to start the car by selecting up to five places on the six-space keypad on which to place their fingers. How many possible handprints can the user choose from if at least one space must be selected?
50. Pizza Jet promotes a special lifetime offer—once you order all possible pizza combinations from Pizza Jet, you can get free pizza for life! Pizza Jet offers a selection of 12 toppings (including cheese) for their pizzas. How many different pizzas must you order from Pizza Jet to qualify for their lifetime offer? Is this possible? Explain.

## 2.2 PROJECT

### ONES, ZEROS, AND THE NUMBER OF REGIONS IN A VENN DIAGRAM

A computer chip is basically a collection of transistors, which are electronic components that work as switches. A transistor can be in one of two states: on or off. In computer engineering, the number 1 is used to represent the *on* state while 0 is used to represent the *off* state. Numbers composed only of zeros and ones are called binary numbers.

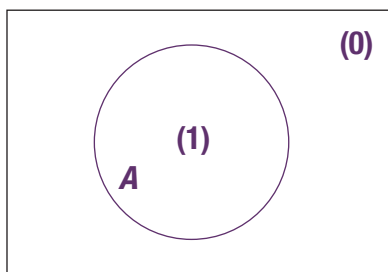

**Figure 1:** One-Set Venn Diagram

In this activity, you will investigate the relationship between binary numbers and the regions of a Venn diagram. Consider the one-set Venn diagram in Figure 1. We have labeled each region of the diagram by asking the question, “Does this region contain elements of set  $A$ ?” If the answer is yes, we labeled the region with (1); if the answer is no, we labeled the region with (0). Table 1 shows a summary of the regions.

**Table 1:** Regions in Figure 1

Elements of Set $A$ ?	Region
Yes	(1)
No	(0)

As you can see, we have exactly 2 regions: (1) and (0). We are labeling the Venn diagram using single digit binary numbers. Let’s use the same idea to label a two-set Venn diagram. (Note that some regions in the figures may end up containing no elements when actual sets are considered, but the diagrams take into account all possible regions when considering the relationship between a fixed number of sets.) The region in Figure 2 that contains no elements of set  $A$  but some of the elements of set  $B$  is labeled (10), and the region that contains no elements of set

## 2.3 Exercises

### ✓ CONCEPT CHECK

- The \_\_\_\_\_ of two sets is represented by the overlapping region in a Venn diagram.
- The \_\_\_\_\_ of two sets contains all elements of the two sets.
- De Morgan's Laws are used to find the \_\_\_\_\_ of the union or intersection of two sets.
- True or False: If two sets are disjoint, then the cardinality of the union of the two sets is equal to the sum of the cardinality of each set.

### 💡 PRACTICE

Use set notation to represent each shaded region.

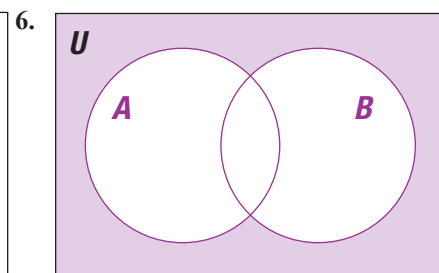
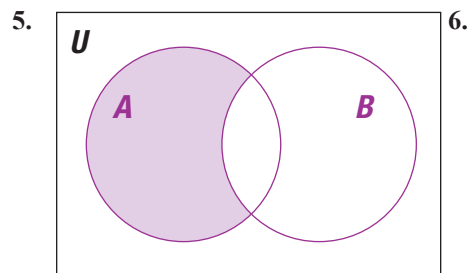

Show that each pair of sets is equal by drawing a Venn diagram of each set.

- $A \cap B$  and  $B \cap A$
- $A \cup B$  and  $B \cup A$
- $(A \cap B) \cap C$  and  $A \cap (B \cap C)$
- $(A \cup B) \cup C$  and  $A \cup (B \cup C)$
- $A \cup \emptyset$  and  $A$

Let  $U = \{1, 2, 3, 4, 5, 6, 7, 8, 9, 10\}$ ,  $A = \{2, 4, 6, 8, 10\}$ , and  $B = \{1, 4, 9\}$ .

- Find  $A \cup B$ .
- Find  $A \cap B$ .
- Find  $|A \cup B|$ .
- Find  $|A \cap B|$ .
- Verify  $(A \cup B)' = A' \cap B'$ .

Let  $U = \{1, 2, 3, 5, 8, 13, 21, 34\}$ ,  $X = \{1, 3, 5, 13, 21\}$ , and  $Y = \{3, 21\}$ .

17. Find  $X \cup Y$ . 18. Find  $X \cap Y$ .  
 19. Find  $|X \cup Y|$ . 20. Find  $|X \cap Y|$ .  
 21. Verify  $(X \cup Y)' = X' \cap Y'$ .

Let  $U = \{a, r, c, h, i, v, e, d\}$ ,  $H = \{h, i, r, e, d\}$ , and  $R = \{r, i, c, h\}$ .

22. Find  $H \cup R$ . 23. Find  $H \cap R$ .  
 24. Find  $|H \cup R|$ . 25. Find  $|H \cap R|$ .  
 26. Verify  $(H \cap R)' = H' \cup R'$ .

Let  $U = \{e, d, u, c, a, t, i, o, n\}$ ,  $D = \{d, a, n, c, e\}$ , and  $N = \{n, o, t, e\}$ .

27. Find  $D \cup N$ . 28. Find  $D \cap N$ .  
 29. Find  $|D \cup N|$ . 30. Find  $|D \cap N|$ .  
 31. Verify  $(D \cap N)' = D' \cup N'$ .

Let  $U = \{c, o, p, y, r, i, g, h, t, a, b, l, e\}$ ,  $B = \{b, i, o, g, r, a, p, h, y\}$ ,  
 $C = \{c, h, i, p, o, t, l, e\}$ , and  $P = \{p, i, r, a, c, y\}$ .

32. Find  $B \cap (C \cup P)$ . 33. Find  $B \cup (C \cap P)$ .  
 34. Find  $P \cup (B \cap C)$ . 35. Verify  $(C \cup P)' = C' \cap P'$ .

Let  $U = \{m, e, l, t, d, o, w, n, s\}$ ,  $S = \{s, n, o, w, m, e, l, t\}$ ,  $M = \{m, o, d, e, l\}$ , and  
 $T = \{t, o, w, e, d\}$ .

36. Find  $S \cap (M \cup T)$ . 37. Find  $S \cup (M \cap T)$ .  
 38. Find  $T \cup (S \cap M)$ . 39. Verify  $(M \cap T)' = M' \cup T'$ .

 APPLICATIONS

Use the Venn diagram to solve each problem.

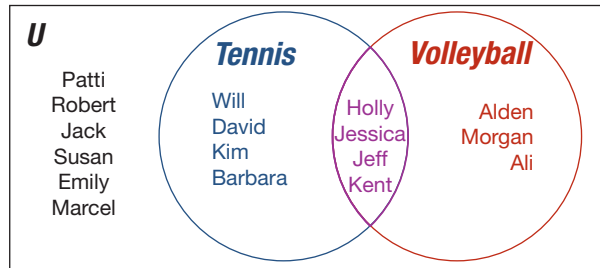

40. Which students played only tennis?
41. Determine which students played tennis or volleyball.
42. Determine which students played tennis and volleyball.
43. Find the number of students that play tennis or volleyball.

Solve.

44. A grocery store found that 275 of its customers use push carts to shop, 185 used a carry basket to shop, and that 145 used both a push cart and a carry basket. How many customers use only a push cart or a carry basket? Draw the Venn diagram.
45. Determine the number of playing cards in a standard deck that are red cards or face cards.
46. Determine the number of playing cards in a standard deck that are odd numbered cards or black cards.

## 2.3 PROJECT

### EXPLORING INTERVALS: INTERSECTIONS AND UNIONS

In Section 2.3, you learned about the intersection and union of sets. In this activity, you will investigate intersections involving sets that cannot be described using roster notation.

Consider the set  $I_1$  of all real numbers that are greater than or equal to 0 and less than or equal to 1. Using set-builder notation, we have  $I_1 = \{x \mid 0 \leq x \leq 1\}$ , which we can also represent using interval notation as  $I_1 = [0, 1]$  or graphically as shown in Figure 1.



Figure 1

Question 3:  $331 - 175 - 150 - 2 = 4$

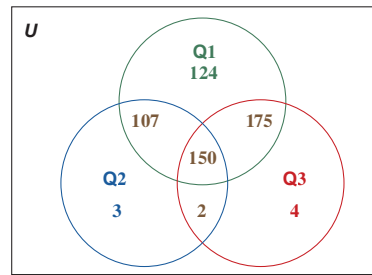

Figure 2.4.20

Finally, subtract all the numbers in the regions (1) through (7) from 1000 to determine how many residents answered No to all three questions.

$$1000 - 124 - 107 - 175 - 150 - 3 - 2 - 4 = 435$$

Figure 2.4.21 shows the completed Venn Diagram.

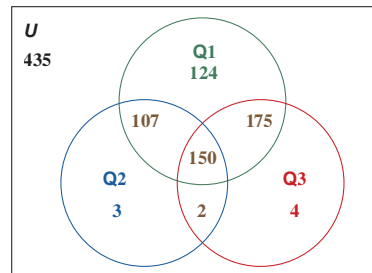
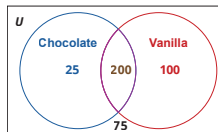

Figure 2.4.21

There were 435 residents who responded No to all three questions.

**Skill Check Answers**

1.  $75$  like neither ice cream.    2. a.  $|A \cap C| = 8$  b.  $|B \cap C| = 2$



3.  $405$  shoppers in the survey.

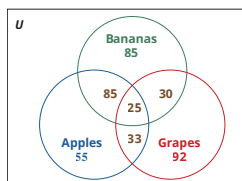

## 2.4 Exercises

✓ CONCEPT CHECK

1. A two-set Venn diagram has a total of \_\_\_\_\_ regions.
2. A three-set Venn diagram has a total of \_\_\_\_\_ regions.

3. True or False: Region (8) of a three-set Venn diagram represents the complement of the union of the three sets.
4. True or False: If three sets are disjoint, then regions (4), (5), and (6) will be empty and regions (1), (2), (3), and (7) will contain elements.

### PRACTICE

5. Construct a Venn diagram illustrating the following sets:  $A = \{\text{apple, orange, grape, peach}\}$ ,  $B = \{\text{grape, banana, apple, kiwi}\}$ , and  $C = \{\text{kiwi, apple, peach, banana}\}$  if  $U = \{\text{apple, orange, peach, grape, banana, kiwi}\}$ .
6. Construct a Venn diagram illustrating the sets:  $A = \{1, 2, 3, 4\}$ ,  $B = \{2, 4, 6, 8, 10\}$ , and  $C = \{3, 4, 6\}$  if  $U = \{1, 2, 3, 4, 5, 6, 7, 8, 9, 10\}$ .

### APPLICATIONS

7. A survey of 400 college freshmen showed that 200 drink soda, 300 drink juice, and 150 drink both. Draw a Venn diagram to determine how many students responded that they drink neither.
8. A survey of 350 students showed that 225 listen to rap and 200 listen to rock and 135 listen to both. Draw a Venn diagram to determine how many students responded that they listen to neither.
9. A researcher collecting data on 100 households finds that 47 have a DVD player; 52 have only streaming video, and 27 have both. Determine the answer to the following questions.
  - a. How many do not have video streaming?
  - b. How many have neither video streaming nor a DVD player?
  - c. How many have a DVD player but not video streaming?
10. A survey of 600 workers yielded the following information: 417 belonged to the Auto Workers Union, 275 were Democrats, and 215 of the Auto Workers Union were Democrats.
  - a. How many workers belonged to the Auto Workers Union or were Democrats?
  - b. How many workers belonged to the Auto Workers Union but were not Democrats?
  - c. How many workers were Democrats but did not belong to the Auto Workers Union?
  - d. How many workers neither belonged to the Auto Workers Union nor were Democrats?

11. A three-course meal is served during the soft opening of a new restaurant. The three-course meal included an appetizer, the main course, and dessert. After the meal, diners were asked whether they enjoyed each course. The following Venn diagram summarizes the results.

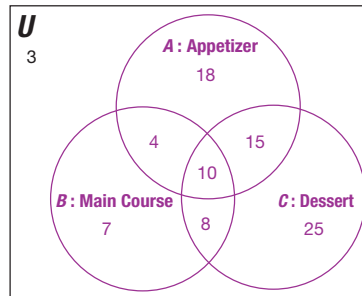

Use the information in the diagram to determine the following and describe what each represents.

- $|A \cup B \cup C|$
  - $|B \cup C|$
12. There are 43 students in the University Travel Club. They discovered that 17 members have visited Mexico, 10 have been to England, 28 have visited Canada, 8 have been to Mexico and Canada, 3 have only been to England, and 4 have only been to Mexico. No student has been to only England and Canada. Two students have been to all three countries. Some of the club members have not been to any of the three.

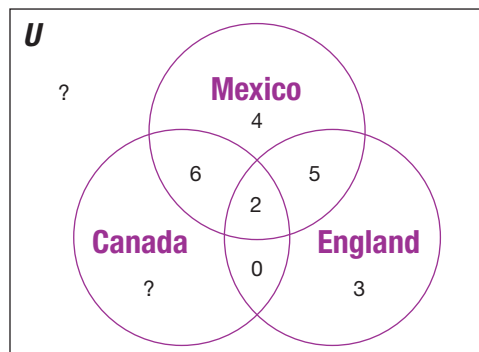

- How many students have been to all three countries?
- How many students have been only to Canada?
- How many have been to Mexico or Canada but not England?
- How many have been to none of the countries?

13. Students were polled on which of the three restaurants in the student center they have purchased food from in the past week. Out of those surveyed, 250 students made a purchase from Pizza Palace, 278 students made a purchase from Maing Wok, 226 students made a purchase from Salad Express, 87 students made a purchase from both Pizza Palace and Maing Wok, 57 students made a purchase from both Pizza Palace and Salad Expression, 95 students make a purchase from both Maing Wok and Salad Express, and 22 students made a purchase from all three restaurants. A total of 63 students replied that they had not made a purchase from any of the restaurants. Draw a Venn diagram to illustrate this survey and determine how many students were polled.
14. A variety show consisted of three acts: music, comedy, and magic. All audience members were asked which acts they enjoyed. Out of those surveyed, 105 enjoyed the music, 122 enjoyed the comedy, 95 enjoyed the magic, 50 enjoyed both the music and the comedy, 37 enjoyed both the music and the magic, 57 enjoyed both the comedy and the magic, and 15 enjoyed all three. Only 7 audience members did not enjoy any of the three acts. Assuming every audience member completed a survey, draw a Venn diagram to illustrate this survey and determine how many people were in the audience.
15. A survey of 125 freshman business students at a large university produced the following results:

35 read *Money*;  
 25 read *The Wall Street Journal*;  
 32 read *Fortune*;  
 21 read *Money* but not *The Wall Street Journal*;  
 11 read *The Wall Street Journal* and *Fortune*;  
 13 read *Money* and *Fortune*;  
 9 read all three.

Use this information to answer the following questions:

- a. How many students read none of the publications?
  - b. How many read only *Fortune*?
  - c. How many students read *Money* and *The Wall Street Journal*, but not *Fortune*?
16. Taylor Swift, Drake, and BLACKPINK toured the United States. A large group of teenagers were surveyed about whether they went to any of the concerts and the following information was obtained: 825 saw Drake, 1033 saw Taylor Swift, 1247 saw BLACKPINK, 211 saw all three, 514 saw none, 240 saw only BLACKPINK, 677 saw BLACKPINK and Taylor Swift, and 201 saw Taylor Swift and Drake but not BLACKPINK.
- a. What percent of the teenagers saw at least one concert?
  - b. What percent of the teenagers saw exactly one concert?

17. A book publishing company asked 400 random customers of a bookstore whether they purchased print books, e-books, or audiobooks in the past year. The results are summarized in the following table.

Bookstore Customer Book Format Preference	
Print Book	149
e-Book	281
Audiobook	215
Print Book and e-Book	98
Print Book and Audiobook	69
e-Book and Audiobook	153
Print Book, e-Book, and Audiobook	42

- How many people purchased none of the three book formats in the past year?
  - How many people purchased e-books and audiobooks but not print books?
  - How many people purchased only print books?
18. An artist sent out a survey with her newsletter asking fans which type of merchandise they would be interested in buying. The options were art prints, T-shirts, and stickers. The results of the 326 fans who completed the survey are shown in the following table.

Merchandise Preference	
Art Prints	153
T-Shirts	121
Stickers	198
Art Prints and T-Shirts	37
Art Prints and Stickers	66
T-Shirts and Stickers	62
Art Prints, T-Shirts, and Stickers	12

- How many fans indicated they would buy none of the options?
- How many fans indicated they would buy art prints and stickers but not T-shirts?
- How many fans indicated they would buy only T-shirts?

 **WRITING & THINKING**

19. There are three types of blood antigens that determine blood type: A, B, and Rh+. An individual's blood type is determined by the specific combination of these antigens. In order to receive a blood transfusion, you can't receive blood from a donor who has an antigen that you don't have yourself. That means that people with AB+ blood can receive a transfusion from ANY donor, since they have all of the possible antigens. They can only donate to other people with AB+. People with O- blood (none of the antigens) can only receive type O- blood, since all other blood types have at least one of the antigens. However, they can donate their blood to anyone, since their blood does not have any of the antigens. A laboratory looked at blood samples for 200 patients and found the following information provided in the table. How many patients were classified as O-? Explain your reasoning.

Blood Antigen Survey Results	
Number of Samples	Antigen in Blood
80	A
36	B
82	Rh
10	A and B
62	A and Rh
22	B and Rh
4	A, B, and Rh

## 2.4 PROJECT

### SET THEORY AND ALLOCATION OF RESOURCES

According to the job interviewing coaches Jeff & Mike *The Interview Guys*,

Analytical skill is the ability for an individual to solve complex issues by gathering and then analyzing the information that is available to them through a variety of other skills including critical thinking, research, and attention to detail.

In this activity, you will solve a seemingly complex allocation of resources problem by using a mathematical model involving Venn diagrams.

A medium-size tech company has to staff 3 distinct departments: Social Media Outreach (SM), Information Technology (IT), and Web Development (WD). The fast-paced and innovative environment at the company may require an employee to be part of more than one department.

The company has the following staffing requirements.

- The total number of employees in the three departments must be exactly 40.
- There must be exactly 16 employees in Information Technology and exactly 20 employees in Social Media Outreach.
- No employee can work in Information Technology and Social Media Outreach without also being a part of Web Development.

## 3.1 Exercises

### ✓ CONCEPT CHECK

1. A \_\_\_\_\_ is a statement that contradicts itself.
2. Negations of a statement has the \_\_\_\_\_ truth value as the original statement.
3. Conjunctions are compound statements that use the connective word \_\_\_\_\_, while disjunctions are compound statements that use the connective word \_\_\_\_\_.
4. True or False: Questions are considered mathematical statements.
5. True or False: The sentence “this statement is false” is an example of a paradox.

### 💡 PRACTICE

Decide if each sentence is a mathematical statement.

6. My computer is fast.
7. The car in front of me is turning around.
8. Who are you voting for in the election?
9. I always lie.
10. Running is fun.
11. Are you cold today?
12. I received 35 e-mails today, half of which ended up in my spam folder.
13. Get out of my room!
14. This computer’s processor is at least 1.8 GHz.
15. Either we are going to the beach or the mountains for vacation this year.
16. No one goes to that mall anymore; it’s too crowded.
17. I will go to the concert if and only if I can get front row seats.

Negate each statement.

18. Kelsey’s website had more than 50,000 visits yesterday.
19. Three hundred twenty-nine people applied for the same job I did.

20. I did not get the job.
21. Austin slept until 8:00 a.m. this morning.
22. None of the Christmas tree lights are not working.
23. Every student is volunteering at the food pantry this year.

Using the letters given to represent simple statements and the proper logic connectives, express each compound statement in symbolic form.

24. It is not true that Miranda likes both art and history.

*m*: Miranda likes art.

*n*: Miranda likes history.

25. Miranda does not like art or Miranda does not like history.

*m*: Miranda likes art.

*n*: Miranda likes history.

26. If I don't eat meat, then I don't get sick.

*a*: I don't eat meat.

*b*: I get sick.

27. I don't get sick or I don't eat meat.

*a*: I don't eat meat.

*b*: I get sick.

28. I will bake cookies if and only if I can give them all away.

*a*: I will bake cookies.

*b*: I can give all the cookies away.

29. If Mrs. Walker is a teacher, then she is not a rocket scientist.

*t*: Mrs. Walker is a teacher.

*r*: Mrs. Walker is a rocket scientist.

30. If Mrs. Walker is not a rocket scientist, then she is a teacher.

*t*: Mrs. Walker is a teacher.

*r*: Mrs. Walker is a rocket scientist.

31. Right angles are formed by the lines if the lines are perpendicular.

*w*: The lines are perpendicular.

*z*: Right angles are formed by the lines.

32. The lines are not perpendicular or right angles are formed by the lines.

$w$ : The lines are perpendicular.

$z$ : Right angles are formed by the lines.

33. I will not adopt a puppy if and only if I have to move next month.

$a$ : I will adopt a puppy.

$b$ : I have to move next month.

Use the given simple statements to write each compound statement in words.

$a$ : Driving makes me smile.

$b$ : I grill more often than I bake.

$c$ : It is sunny.

34.  $b \wedge a$

35.  $a \vee c$

36.  $c \wedge \sim b$

37.  $c \Rightarrow b$

38.  $\sim a \Leftrightarrow c$

39.  $\sim c \Rightarrow \sim b$

Use the given simple statements to write each compound statement in words.

$p$ : My video reached 1000 views on YouTube.

$q$ : I have 1000 Facebook friends.

$r$ : The home page of my website has a bounce rate of less than 20%.

40.  $p \wedge q$

41.  $\sim q \Rightarrow \sim r$

42.  $q \vee p$

43.  $\sim r \Leftrightarrow \sim p$

Use the given statements to write each compound statement in words.

$p$ : The moon is full.

$q$ : I don't know if it's cloudy or bright outside.

$r$ : I've lost my glasses.

44.  $p \wedge r$

45.  $(\sim p) \vee q$

46.  $\sim(q \wedge r)$

47.  $p \Leftrightarrow \sim q$

48.  $r \Rightarrow q$

49.  $\sim r \Rightarrow \sim q$

## 3.2 Exercises

### ✓ CONCEPT CHECK

1. Truth tables are used to keep track of different possible \_\_\_\_\_ for a mathematical statement.
2. A conjunction of two statements  $a$  and  $b$  is true when \_\_\_\_\_.
3. A disjunction of two statements  $a$  and  $b$  is true unless \_\_\_\_\_.
4. True or False: The statement “if today is Sunday, then I will eat a sundae” is false if today is Tuesday and I eat a Sunday.
5. True or False: The statement “the snow will melt if and only if the temperature is above freezing” is true if the snow doesn’t melt and the temperature is below freezing.

### 💡 PRACTICE

Complete each truth table.

6.  $a \wedge \sim b$

Truth Table			
$a$	$b$	$\sim b$	$a \wedge \sim b$
T	T		
T	F		
F	T		
F	F		

7.  $\sim w \vee \sim z$

Truth Table				
$w$	$z$	$\sim w$	$\sim z$	$\sim w \vee \sim z$
T	T			
T	F			
F	T			
F	F			

8.  $c \Rightarrow \sim d$

Truth Table			
$c$	$d$	$\sim d$	$c \Rightarrow \sim d$
T	T		
T	F		
F	T		
F	F		

9.  $m \leftrightarrow \sim n$

**Truth Table**

$m$	$n$	$\sim n$	$m \leftrightarrow \sim n$
T	T	F	F
T	F	T	T
F	T	F	F
F	F	T	T

10.  $\sim(p \Rightarrow q)$

**Truth Table**

$p$	$q$	$p \Rightarrow q$	$\sim(p \Rightarrow q)$
T	T	T	F
T	F	F	T
F	T	T	F
F	F	T	F

11.  $\sim(s \Leftrightarrow t)$

**Truth Table**

$s$	$t$	$s \Leftrightarrow t$	$\sim(s \Leftrightarrow t)$
T	T	T	F
T	F	F	T
F	T	F	T
F	F	T	F

12.  $(a \vee b) \vee c$

**Truth Table**

$a$	$b$	$c$	$a \vee b$	$(a \vee b) \vee c$
T	T	T	T	T
T	T	F	T	T
T	F	T	T	T
T	F	F	T	T
F	T	T	T	T
F	T	F	T	T
F	F	T	F	T
F	F	F	F	F

13.  $(p \vee r) \Rightarrow q$

**Truth Table**

$p$	$r$	$q$	$p \vee r$	$(p \vee r) \Rightarrow q$
T	T	T	T	T
T	T	F	T	F
T	F	T	T	T
T	F	F	T	F
F	T	T	T	T
F	T	F	T	F
F	F	T	F	T
F	F	F	F	T

14.  $(\sim a \wedge \sim b) \wedge \sim c$

Truth Table						
$a$	$b$	$c$	$\sim a$	$\sim b$	$\sim c$	$(\sim a \wedge \sim b) \wedge \sim c$
T	T	T	F	F	F	F
T	T	F	F	F	T	F
T	F	T	F	T	F	F
T	F	F	F	T	T	F
F	T	T	T	F	F	F
F	T	F	T	F	T	F
F	F	T	T	T	F	F
F	F	F	T	T	T	F

15.  $(m \wedge n) \Leftrightarrow r$

Truth Table				
$m$	$n$	$r$	$m \wedge n$	$(m \wedge n) \Leftrightarrow r$
T	T	T	T	T
T	T	F	T	F
T	F	T	F	F
T	F	F	F	T
F	T	T	F	F
F	T	F	F	T
F	F	T	F	F
F	F	F	F	T

16.  $\sim p \Rightarrow (q \vee r)$

Truth Table					
$p$	$q$	$r$	$\sim p$	$q \vee r$	$\sim p \Rightarrow (q \vee r)$
T	T	T	F	T	T
T	T	F	F	T	T
T	F	T	F	T	T
T	F	F	F	F	F
F	T	T	T	T	T
F	T	F	T	T	T
F	F	T	T	F	F
F	F	F	T	F	F

17.  $(\sim b \leftrightarrow c) \Rightarrow \sim a$

Truth Table						
$a$	$b$	$c$	$\sim a$	$\sim b$	$\sim b \leftrightarrow c$	$(\sim b \leftrightarrow c) \Rightarrow \sim a$
T	T	T	F	F	F	T
T	T	F	F	F	T	F
T	F	T	F	T	T	F
T	F	F	F	T	F	T
F	T	T	T	F	F	T
F	T	F	T	F	T	F
F	F	T	T	T	T	F
F	F	F	T	T	F	T

Convert each compound statement into variables and then construct the truth table for the compound statement.

18. We will buy a new smartphone or we will buy a new computer.
19. I plan to go to the movies and go out to eat this weekend.
20. Ella is not on the dance team and Coleman is on the soccer team.
21. My calculator is not working correctly and I need to buy a new one if and only if it calculates that one plus one equals three.
22. If it rains and you don't put the convertible hood up, the inside of your convertible will get wet.
23. If Meg doesn't get gas, then her car will break down and she will miss her exam.

Use a truth table to determine if each statement is a tautology.

24.  $(\sim p \vee \sim q) \vee (p \wedge q)$

25.  $w \Rightarrow v$

26.  $(m \wedge n) \vee (\sim n)$

27.  $(a \wedge \sim b) \vee (a \Rightarrow b)$

Convert each compound statement into variables and create a truth table for the given statement. Then determine whether it is a tautology.

28. If I like the cake, then it is chocolate, or if the cake is chocolate, then I like the cake.
29. If the bird is blue or green, then the bird is not from here.
30. You wrote the love letter if and only if you liked her, or you did not write the love letter if and only if you did not like her.
31. The animal is a penguin implies it wears a bow tie if and only if the animal does not wear a bow tie implies it is not a penguin.

**Solution**

The statement we are given is a conditional statement,  $a \Rightarrow b$ , where  $a$  is the statement “I save enough money” and  $b$  is the statement “I will go on a vacation.” Now we can write each of the variations.

Converse ( $b \Rightarrow a$ ): If I go on vacation, then I saved enough money.

Inverse ( $\sim a \Rightarrow \sim b$ ): If I do not save enough money, then I will not go on vacation.

Contrapositive ( $\sim b \Rightarrow \sim a$ ): If I do not go on vacation, then I did not save enough money.

The contrapositive is logically equivalent to the original statement.

**✓ Skill Check 3.3.3**

Write the converse, inverse, and contrapositive of the following statement.

*If I cannot find my phone, then it is in the car.*

**Skill Check Answers**

1. Truth Table for  $a$  and  $a \vee a$

$a$	$a$	$a \vee a$
$T$	$T$	$T$
$F$	$F$	$F$

2. The weather gets worse and we will not leave. 3. Converse: If my phone is in the car, then I cannot find it. Inverse: If I can find my phone, then it is not in the car. Contrapositive: If my phone is not in the car, then I can find it.

## 3.3 Exercises

**✓ CONCEPT CHECK**

- \_\_\_\_\_ statements have exactly the same truth values in all corresponding circumstances.
- De Morgan's Laws define the negation of two \_\_\_\_\_.
- The negation of a conditional statement is a \_\_\_\_\_.
- True or False: The statement “if the dog is a good boy, then he gets a treat” is logically equivalent to “if the dog did not get a treat, then he is not a good boy.”
- True or False: The statement “if the calculator gives me the wrong answer, then it is broken” is logically equivalent to “if the calculator is broken, then it gives me the wrong answer.”

**PRACTICE**

Complete each truth table for the given tautology and then decide which two statements within the compound statement are logically equivalent, if applicable.

6.  $(p \Rightarrow \sim q) \Leftrightarrow \sim(p \wedge q)$

**Truth Table**

$p$	$q$	$\sim q$	$p \Rightarrow \sim q$	$p \wedge q$	$\sim(p \wedge q)$	$(p \Rightarrow \sim q) \Leftrightarrow \sim(p \wedge q)$
T	T	F	F	T	F	F
T	F	T	T	F	T	T
F	T	F	T	F	T	T
F	F	T	T	F	T	T

7.  $\sim(p \Rightarrow q) \Rightarrow (p \vee q)$

**Truth Table**

$p$	$q$	$p \Rightarrow q$	$\sim(p \Rightarrow q)$	$p \vee q$	$\sim(p \Rightarrow q) \Rightarrow p \vee q$
T	T	T	F	T	T
T	F	F	T	T	T
F	T	T	F	T	T
F	F	T	F	F	T

8.  $(\sim p \wedge \sim q) \Leftrightarrow \sim(p \vee q)$

**Truth Table**

$p$	$q$	$\sim p$	$\sim q$	$\sim p \wedge \sim q$	$p \vee q$	$\sim(p \vee q)$	$(\sim p \wedge \sim q) \Leftrightarrow \sim(p \vee q)$
T	T	F	F	F	T	F	F
T	F	F	T	F	T	F	F
F	T	T	F	F	T	F	F
F	F	T	T	T	F	T	T

9.  $[p \wedge (\sim p \vee q)] \Leftrightarrow (p \wedge q)$

**Truth Table**

$p$	$q$	$\sim p$	$\sim p \vee q$	$p \wedge (\sim p \vee q)$	$p \wedge q$	$[p \wedge (\sim p \vee q)] \Leftrightarrow (p \wedge q)$
T	T	F	T	T	T	T
T	F	F	F	F	F	T
F	T	T	T	F	F	T
F	F	T	F	F	F	T

Show that each pair of statements is logically equivalent or explain why they are not.

10. a.  $a \Rightarrow b$                       b.  $b \Rightarrow a$

11. a.  $n \Rightarrow m$                       b.  $m \vee \sim n$

12. a.  $p \wedge \sim q$                       b.  $\sim(\sim p \vee q)$   
 13. a.  $r \wedge \sim s$                       b.  $\sim(r \Rightarrow s)$   
 14. a.  $w \Rightarrow z$                       b.  $\sim w \Rightarrow \sim z$   
 15. a.  $p \vee q$                               b.  $p \vee (q \wedge \sim p)$

Write the negation of the given compound statement using De Morgan's laws.

16. The band will go on tour, or the band will release a new album and film a new music video.  
 17. The dog will wear a bow tie and will not wear a hat, and the dog will have his picture taken.

De Morgan's Laws state that  $\sim(p \wedge q) \equiv \sim p \vee \sim q$  and  $\sim(p \vee q) \equiv \sim p \wedge \sim q$ . Construct a truth table to show that each pair of compound statements is logically equivalent.

18.  $\sim(p \wedge q)$  and  $\sim p \vee \sim q$                       19.  $\sim(p \vee q)$  and  $\sim p \wedge \sim q$

Use De Morgan's Laws to write an equivalent statement without using parentheses.

20.  $\sim(\sim p \wedge q)$     21.  $\sim(\sim p \vee \sim q)$

Use De Morgan's Laws to write an equivalent statement.

22.  $\sim p \wedge q$     23.  $p \vee q$

Negate each conditional statement.

24.  $\sim p \Rightarrow a$     25.  $a \Rightarrow (c \vee d)$   
 26.  $(c \wedge d) \Rightarrow b$     27.  $(w \vee z) \Rightarrow (w \wedge z)$

28. If Brooke comes to my room before 2:00 p.m. then I do not finish my homework before 10:00 p.m.  
 29. My computer goes to sleep whenever I leave it alone for 15 minutes.  
 30. Having a ticket from the Sunday paper is sufficient to get a free ice cream at Dairy Dip.  
 31. Being in Charleston, South Carolina, implies that I am on Eastern Standard Time.  
 32. Consider the conditional statement "If the weather is cold enough, we will go ice skating." Determine if the following conditional statements are logically equivalent to the given conditional statement.  
 a: If we go ice skating, then the weather is cold enough.  
 b: If we do not go ice skating, then the weather is not cold enough.  
 c: We will go ice skating if and only if the weather is cold enough.

33. Consider the conditional statement “If the puppy is not asleep, then the puppy is causing mischief.” Determine if the following conditional statements are logically equivalent to the given conditional statement.
- a: If the puppy is not causing mischief, then the puppy is asleep
  - b: If the puppy is asleep, the puppy is not causing mischief.
  - c: The puppy is asleep or the puppy is causing mischief.

Use De Morgan’s Laws to write an equivalent statement.

34. There is a space available in the 8:00 a.m. Biology class or I am not able to make the perfect schedule for next semester.
35. In Biology the nucleotide bases adenine and thymine pair together in DNA and the bases do not pair together in RNA.

Write the converse, inverse, contrapositive, and biconditional for each conditional statement.

36. If I go to the movies, then I will get popcorn.
37. Getting an 89 on the final is sufficient for me to get an A in biology.
38. It is dark whenever I get out of my last class.
39. Seeing a puppy will lead to me smiling.

Find each conditional variation.

40. Find the inverse of  $p \Rightarrow q$ .
41. Find the converse of  $\sim q \Rightarrow p$ .
42. Find the contrapositive of  $\sim p \Rightarrow q$ .
43. Find the inverse of  $\sim q \Rightarrow \sim p$ .

**Skill Check Answers**

1. Premise 1: If the weather is warm, we will go the beach. Premise 2: We're at the beach. Conclusion: It is warm outside. 2. Invalid 3. The argument is sound. 4. *Non sequitur*

## 3.4 Exercises

### ✓ CONCEPT CHECK

1. In an argument, the \_\_\_\_\_ provides support for the argument and the \_\_\_\_\_ is the ending statement.
2. A \_\_\_\_\_ is a statement that is true in every single possible circumstance.
3. A \_\_\_\_\_ argument must have true premises.
4. True or False: An argument can be valid as long as there is a logical connection between the premise and conclusion, even if the conclusion seems like nonsense.
5. True or False: Fallacies are caused by a faulty line of reasoning to reach a conclusion.

### 💡 PRACTICE

Identify the premise and conclusion in each argument.

6. “If the owners truly cared about the game and the fans, they would lift the lockout and allow the season to begin on time while negotiations continue,” NHLPA Executive Director Donald Fehr said.<sup>3</sup>
7. “Even if we stopped burning fossil fuels today, there is enough carbon dioxide in the atmosphere—and it is such a persistent, lasting gas—that temperatures will continue to rise for a few hundred years.”<sup>4</sup>
8. The sea level is rising because melting glaciers and ice sheets are adding more water to the oceans.
9. Fast food obesity has strikingly increased in many countries because of the easy availability of fast food in the grocery shops, gas stations and dispensers everywhere. So it is difficult to escape from the lure of these delicious advertisements and showcases.<sup>5</sup>
10. The current US population is approximately 314 million, about half of which are males, so if 2 percent of the 157 million American men suffer from one of these severe disorders (schizophrenia, major depression, or psychopathy), this results in a figure of 3,140,000.<sup>6</sup>

3 BBC, <http://www.bbc.co.uk>

4 BBC, <http://www.bbc.com>

5 ygoy, <http://www.ygoy.com>

6 *The Chronicle of Higher Education*, <http://www.chronicle.com>

11. “If a man is struck down by a heart attack in the street, Americans will care for him whether or not he has insurance.”<sup>7</sup>
12. An excerpt from the TV show *The West Wing*:<sup>8</sup>  
 Press secretary, C. J., says, “. . . *USA Today* asks you (the president) why you don’t spend more time campaigning in Texas and you say because you don’t look good in funny hats.”  
 “It was *big hats*,” Sam corrects her.  
 “The point is we got whomped in Texas,” C. J. states.  
 “We got whomped in Texas twice,” Josh adds.  
 “We got whomped in the primary and we got whomped in November,” says C. J.  
 “I think I was there,” replies the president.  
 “And it was avoidable. Sir.”  
 “C. J. on your tombstone, it’s going to read, ‘Post hoc, ergo propter hoc.’”

13. A cartoon by Randy Glasbergen.<sup>9</sup>



14. “Dear Friend, a man who has studied law to its highest degree is a brilliant lawyer, for a brilliant lawyer has studied law to its highest degree.” Oscar Wilde, *De Profundis*.
15. All potatoes have skin. I have skin. Therefore, I must be a potato.
16. During the fall of 2011, the movement “Occupy Wall Street” spread almost overnight into a nationwide/worldwide phenomenon. Many famous personalities voiced their opinions both for and against the movement. One film star claimed, “. . . they’re a bunch of posers, propping up the same corporate giant they’re trying to take down. I find it a little ironic that most of these kids not only own all the latest technology, but use it constantly while pretending to ‘take a stand.’ They’re a major player in the consumerism that goes on in this country.”

Determine whether each argument uses inductive or deductive reasoning, and whether the reasoning is valid.

17. The number pi ( $\pi$ ) begins with 3.14159. Four is the only even digit when you write out the number  $\pi$ .

7 Fox News, <http://www.foxnews.com>  
 8 Sorkin, *The West Wing*  
 9 Courtesy of Randy Glasbergen  
 ©HAWKES LEARNING

18. We have put up our Christmas tree the day after Thanksgiving every year for the last 5 years. A photograph from 2 years ago shows our Christmas tree in the background, so it couldn't have been taken before Thanksgiving.
19. We have put up our Christmas tree the day after Thanksgiving every year for the last 5 years. It's Black Friday today, so we must be putting up the Christmas tree.
20. All of my friends have smartphones. They must be the most popular type of cell phone.
21. In a survey of 200 adults, 5 out of 7 people said they carry smartphones as their cell phone. With 95% confidence, I can say that most people carry a smartphone as their cell phone.

Determine whether each argument is valid or invalid.

22. All pigs are pink. I am pink, therefore I must be a pig.
23. All professors at the university received a 3% raise this year. My dad is a psychology professor at the university, so he must have gotten a raise.
24. To renew a US passport for a child under 16, you need to demonstrate that he or she is a US citizen with either a US birth certificate or a valid US passport. I am renewing my daughter's passport, so I need her birth certificate.
25. Most people who live in California are Democrats. Stephanie lives in California, so she must be a Democrat.
26. All dogs bark. I have a dog. Therefore, my dog barks.
27. If it rains, I will need an umbrella. I do not need my umbrella so it must not be raining.
28. Most people who live in Kansas are Republicans. Jim lives in Kansas. Therefore, Jim is a Republican.

Determine the missing piece of information needed to make each argument valid.

29. I can only carry a bottle of liquid that is at most 3.4 fl oz in my carry-on luggage while flying. A larger bottle will be confiscated by airport security. My hand sanitizer got taken away when I went through airport security.
30. I was born on US soil. Therefore, I am a US citizen.
31. Whenever I play folk music, I tune my guitar to an open D tuning. This evening I am playing some folk music.
32. I am tired, so it must be late.

33. If you are not over 16, then you cannot apply for a driver's license in the state of Tennessee. Emma applied for a driver's license.
34. To get into the local state university, you must have a cumulative ACT score of at least 21. Ben's cumulative ACT score is less than 21.
35. If you buy a new car, then you cannot pay your student loan bills. You are able to pay your student loan bills.

Use a truth table to determine if the given argument is a sound argument.

36. If an album receives platinum certification, then at least 1,000,000 copies of the album were sold. Taylor Swift's album *Lover* received platinum status on September 27, 2019. So at least 1,000,000 copies of Taylor Swift's album *Lover* were sold.
  - a. Determine the premises and conclusion of the argument.
  - b. Write the argument using logic symbols.
  - c. Use a truth table to determine whether the argument is a valid argument.
  - d. Is the argument sound? Explain why or why not.
37. If a movie is extremely popular and financially successful, then it is considered a blockbuster. The 2009 movie *Avatar* was not a blockbuster. Therefore, *Avatar* was not popular nor financially successful.
  - a. Determine the premises and conclusion of the argument.
  - b. Write the argument using logic symbols.
  - c. Use a truth table to determine whether the argument is a valid argument.
  - d. Is the argument sound? Explain why or why not.

Identify the type of fallacy being used in each statement.

38. "Some people believe the answer to this problem is to wall off our economy from the world," he said this month in India, talking about migration of US jobs overseas. "I strongly disagree."
39. You must be an atheist. You never go to church on a Sunday morning.
40. On a discussion of the Treaty of Versailles in a history class, a student responds, "You said this happened five years before Hitler came to power. Why are you so fascinated with Hitler? Are you anti-Semitic?"
41. After hitting the side of the television, the picture on Emma's old television goes back into focus. Emma tells Karan that hitting the television fixed it.
42. Everyone drives over the speed limit on this road, so the city should raise the speed limit.
43. Can we really take his opinion on Star Wars seriously? He's a Star Trek fan!
44. It's healthy to take vitamins every day because they are good for you.
45. This cookie you made is burnt. You must be terrible at making cookies.

**Example 4.1.12****Finding Proportions and Ratios**

Suppose you earned a B on your last History 102 test by getting 80% of the questions correct.

- If there were 60 equally weighted questions on the test, how many did you answer correctly?
- What was your ratio of correct to incorrect answers on the test?

**Solution**

- a. We know that you correctly answered 80%, or  $\frac{80}{100}$ , of the questions. We can find 80% of the 60 questions by multiplying the two numbers together as shown.

$$\frac{80}{100} \cdot 60 = 48$$

Therefore, you correctly answered 48 questions on the test.

- b. Since we know from part a. that you correctly answered 48 questions, we can subtract this from the total number of questions to find the number of questions that you answered incorrectly

$$60 - 48 = 12 \text{ incorrect answers}$$

Therefore, the ratio of correct to incorrect answers would be written as 48 : 12, or 4 : 1.

**Skill Check Answers**

- $\frac{5}{12} \approx 41.67\%$
- 15 : 1 children to providers

## 4.1 Exercises

**✓ CONCEPT CHECK**

- A proportion is a \_\_\_\_\_ of a whole.
- To write a proportion as a fraction in lowest terms, divide both the numerator and the denominator by the \_\_\_\_\_.
- A \_\_\_\_\_ is an amount per 100.
- True or False: If a flag has the colors green and purple in the ratio 1 : 2, there is twice as much purple as there is green.
- True or False: The ratio 3 : 1 is equivalent to the ratio 1 : 3.

 PRACTICE

Change each fraction to a percentage. Round your answer to the nearest hundredth when necessary.

6.  $\frac{20}{45}$

7.  $\frac{1}{5}$

8.  $\frac{2}{3}$

9.  $\frac{61}{212}$

10. Which is greater, half of 22 or one-fifth of 95?

11. Which is greater, a third of 36 or one-sixth of 138?

12. Which is greater, half of 42 or twenty-five percent of 120?

13. Which is greater, one-third of 93 or thirty percent of 110?

14. The ratio of 9.2 to 24 is the same as the ratio of \_\_\_\_ to 6.

15. The ratio of 1.2 to 32 is the same as the ratio of 3.6 to \_\_\_\_.

Find the equivalent ratio.

16. a.  $1:7 = \_ : 14$

b.  $1:7 = \_ : 21$

c.  $1:7 = 4: \_$

d.  $1:7 = 5: \_$

17. a.  $2:5 = 4: \_$

b.  $2:5 = \_ : 35$

18. a.  $10:3 = \_ : 9$

b.  $10:3 = 5: \_$

19. a.  $5:9 = 2.5: \_$

b.  $5:9 = \_ : 13.5$

For each ratio, write two equivalent ratios, one of which is in the lowest terms possible.

20.  $25 : 45$

21.  $24 : 60$

22.  $12 : 36 : 72$

23.  $25 : 75 : 45$

 APPLICATIONS

24. For their social media account, a local bakery created a pie chart indicating the popularity of the pies they sold over the past months. Use the pie chart to determine the proportion of pies sold that were **a.** apple and **b.** French silk. Write each proportion in lowest terms.

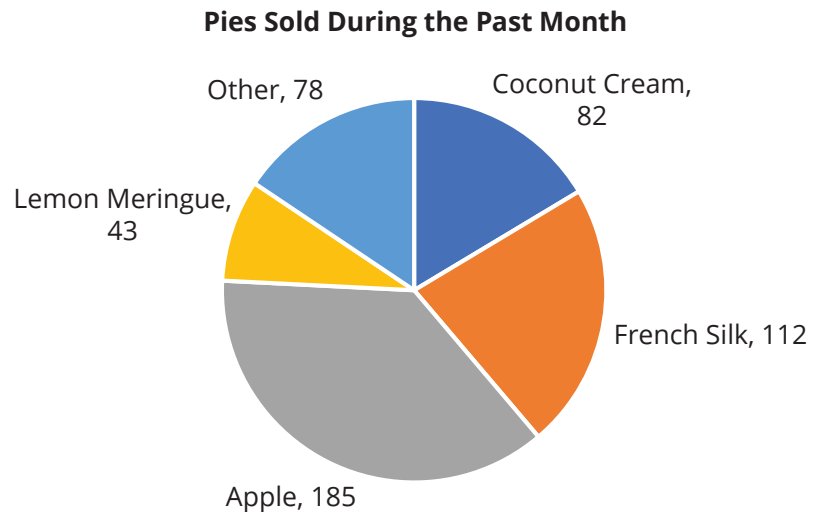

25. A Richardson's family monthly budget for necessary expenses is shown in the table. Use the table to determine the proportion of the budget assigned to **a.** childcare and **b.** groceries. Write each proportion in lowest terms.

**Richardson Family Monthly Budget**

Childcare	\$750
Groceries	\$800
Utilities	\$300
Vehicle Loan Payment and Expenses	\$525
Other	\$425

26. Alexander expects to spend \$10,500 on college tuition and expenses for the next school year. Of that total amount, he expects to spend \$1200 on textbooks and course supplies. Write the proportion of textbooks and course supplies to college tuition and expenses in lowest terms.
27. A 950 calorie meal from a fast food restaurant is made up of a cheeseburger (520 calories), fries (220 calories), and a fountain drink (210 calories). Write the calories in the cheeseburger and the calories in the entire meal as a proportion in lowest terms.
28. If there are 48 students in a class and 32 are seniors, what proportion of students are *not* seniors?
29. In a survey, 99 out of 100 people are *not* left-handed. What proportion of people are left-handed according to this survey?
30. Nearly two-in-ten American women end their childbearing years without having borne a child. What proportion of American women end their childbearing years with having borne a child?

31. A survey indicated that 11 out of 100 students studying at a university reported having a disability. What proportion of students did *not* report having a disability?
32. If the drinks portion of a bill costs \$18 and the total bill was \$30, what percentage of the total was the cost of the drinks?
33. College University sent out 2000 requests to alumni for scholarship fund donations. In response, the university received 325 donations. What percent of alumni donated to the scholarship fund?
34. A student at a state college is expected to spend \$7400 per semester on tuition, fees, and other expenses. If a student at the same college is expected to spend \$700 on textbooks and course supplies, what percentage of the total is the cost of textbooks and course supplies?
35. If the monthly expense for a car is \$600 and the cost of fuel for a month is \$180, what percentage of the total expenses is the cost of fuel?
36. A city parks and recreation department is planning to build a new community park with a playground in one of three possible locations. The park will be built only in an area where at least 60% of the residents approve of the location. The table shows the results of a survey of city residents. Determine which locations meet the minimum approval requirement.

**Citizen Approval of Park Location**

	Location A	Location B	Location C
Approve of Location	17,739	13,298	15,265
Disapprove of Location	5628	9766	7947
No Opinion	1416	1719	1571
Total	24,783	24,783	24,783

37. A brand of cookie is planning to release a new special edition flavor selected by fans, but will only release a flavor if at least 75% of fans think the potential flavor is delicious and not gross. The table shows the results of an online poll. Determine which flavors meet the minimum approval requirement.

**Fan Flavor Poll Results**

	Green Tea	Toffee	Peach Mango
Delicious	6341	8826	9402
Gross	4227	2753	3283
Total	10,568	11,579	12,685

38. From 2006 to 2016, the number of people in the US age 65 and older increased by 33%. Six of the states that experienced a large increase are given below along with the proportion of their state population that is age 65 and older and the number of residents in the state. Determine the number of residents age 65 and older in each of the states listed, and then use these numbers to order the states from largest to smallest. (Round your answer to the nearest whole number of residents.)

State	Proportion of Residents Age 65 and Older	# of Residents
Utah	10.5%	3,058,705
Colorado	13%	5,719,415
Nevada	15%	2,940,947
Idaho	15%	1,699,927
South Carolina	16.7%	4,971,449
Delaware	17.5%	954,000

39. In the 2020 election, 66.7% of the Eligible Voting Population in the country voted. The proportion of eligible voters who voted is given for five states, as well as the number of eligible voters in the state. Determine the number of votes cast in each of the states listed, and then use these numbers to order the states from largest to smallest. (Round your answer to the nearest whole number of votes.)

State	Proportion of Eligible Voters who Voted	# of Eligible Voters
Tennessee	59.81%	5,124,867
Louisiana	64.61%	3,373,932
Illinois	67.02%	9,027,082
Iowa	73.25%	2,321,131
Minnesota	79.96%	4,118,462

40. A car's weight depends on all of its component materials, with steels, aluminum, plastics, and rubber being some of the biggest contributors. Approximately 53.41% of the weight comes from steels, 9.96% from aluminum, 8.24% from plastics, 4.93% from rubber, and 23.46% from other materials. If a car weighs 3994 lb, what is the weight of the plastics used in the car?
41. A website reports that 14% of the world's population is Hindi and 33% are Christian. If there are approximately 6,840,507,000 people in the world, how many are Hindi and how many are Christian according to the website?
42. There is a herd of cattle out on the range. Fifty-two percent of the cattle are male. If the herd consists of 1175 animals, how many are female?
43. Seventy percent of the animals in a zoo are herbivores. If there are 821 animals in the zoo, how many are *not* herbivores? Round your answer to the nearest whole number.

44. According to a survey by Airlines for America taken in 2017, 88% of Americans had flown on a commercial airline in their lifetime. If there are 75 people in Room A and 50 people in Room B, estimate how many people in each room had flown on a commercial airline in their lifetime.
45. The US Census Bureau's Educational Attainment report released in 2020 stated that approximately 23% of people 25 and older had earned a bachelor's degree. If City A has 10,726 citizens aged 25 and older and City B has 8253 citizens aged 25 and older, approximately how many citizens aged 25 and older from each city have a bachelor's degree?
46. Approximately 1.5% of the population have a peanut allergy. If East Central Middle School has 1180 students and West Chester Middle School has 1373 students, approximately how many students at each school have a peanut allergy?
47. Approximately 2% of the population has naturally red hair. The population of Utah is approximately 3.2 million and the population of South Dakota is approximately 885,000. Approximately how many people with naturally red hair live in each state?
48. Three-fourths of the students at the local community college live in the county. If there are 2004 students enrolled, how many do *not* live in the county?
49. At a recent education conference, one-fourth of the total participants came to learn about online courses. The rest came to learn about other educational practices. If 92 participants showed up, how many were *not* there to learn about online courses?
50. A general guideline for making cocktails at home is to follow the ratio 2 : 1 : 1—spirit : sweet : tart.
- Write a fraction to represent the relationship of spirit to tart as indicated by the ratio.
  - If 4 ounces of spirit was used to mix a drink, how much of the tart ingredient would be required?
51. The Wilton icing coloring color chart states that to create burgundy colored icing, you need to add food coloring in the ratios 3 : 2 : 2—rose : red-red : black.
- Write a fraction to represent the relationship of rose to red-red as indicated by the ratio.
  - If 12 drops of rose food coloring were added to the icing, how many drops of black food coloring should be added to make burgundy icing?

52. A website claims that the ideal fertilizer for flowering shrubbery is created by combining two different fertilizers with water at a ratio of  $5 : 3 : 2$ —water : Sunny Shrub fertilizer : Flower Friends fertilizer.
- Write a fraction to represent the relationship of Flower Friends fertilizer to water as indicated by the ratios.
  - If a gardener fills a container with 40 fluid ounces of water, how many fluid ounces of Sunny Shrub fertilizer should be added to create this ideal fertilizer for flowering shrubbery?
53. A recipe for hard candy indicates that the ingredients should be mixed at a ratio of  $8 : 6 : 2$ —granulated sugar : corn syrup : water.
- Write a fraction to represent the relationship of corn syrup to the whole as indicated by the ratio.
  - If someone following the recipe only had 4 cups of sugar, how many cups of corn syrup would be needed to make the hard candy?
54. Each week, a city-run afterschool tutoring program has 72 tutor volunteers and helps 243 students. Write the ratio of tutor volunteers to students and determine the number of people who participate in the afterschool tutoring program.
55. A recent population study of elephants revealed that due to population declines there are only 50,000 wild Asian elephants and 415,000 wild African elephants in the world. Write the ratio of Asian elephants to African elephants and calculate the total number of elephants living in the wild according to this study.
56. As part of a weeklong fundraising campaign, club members sold 476 brownies and 392 cupcakes during bake sales. Write the ratio of cupcakes to brownies and determine the total number of baked goods sold during the bake sales.
57. At a state college, a recent survey performed by the campus technology department revealed that 10,473 students had a phone with a Google Android operating system and 12,748 students had a phone with an Apple iOS operating system. Write a ratio of students with Apple iOS to students with Google Android and determine the total amount of students surveyed.
58. If 9 of the 21 members of a tour group are children, what is the ratio of children to adults on the trip?
59. Triangles A and B are *similar* triangles. In other words, triangle B has exactly the same shape as Triangle A, just a different scale. Triangle A has sides 45 cm, 54 cm, and 99 cm. If Triangle B has sides of lengths 90 cm, 108 cm, and 198 cm, what is the ratio of the lengths of the sides of Triangle A to the lengths of the sides of Triangle B?

60. A bag contains the following marbles: 8 black marbles, 17 blue marbles, 7 brown marbles, and 14 green marbles.
- What is the ratio of brown marbles to black marbles?
  - What is the ratio of brown marbles to all the marbles in the bag?
61. A recent study showed that in American universities there were 18 million college students and 1.3 million faculty. Write the overall student to faculty ratio for universities across America in lowest terms.
62. Christopher had acquired 12 of the 20 items requested by his supervisor. Write the ratio of acquired items to nonacquired items in lowest terms.
63. Almost 30% of the world's billionaires live in 15 major cities. The city with the most billionaires is New York City with 113 billionaires among its population of approximately 8.4 million. This equates to 1 billionaire for each 74,336 residents, which we can write as 1 : 74,336. The data for five other cities is given below.

City	# of Billionaires	Population
Mumbai, India	38	20,000,000
Los Angeles, USA	44	4,000,000
Beijing, China	57	20,400,000
London, UK	66	9,300,000
Moscow, Russia	73	12,500,000

- Write a unit ratio for each of the given cities, rounding to the nearest whole person.
  - Compare the ratio of billionaires for each city to New York City.
64. An 8 oz cup of brewed coffee contains 96 mg of caffeine. The caffeine content of four other beverages is given below.

Beverage	Size in oz	Caffeine in mg
Espresso	1	64
Black tea	16	94
Green tea	12	42
Cola	24	66

- Write an equivalent ratio for the caffeine content of each beverage.
  - Compare the caffeine content of each beverage to that of brewed coffee.
65. If the ratio of tourists to locals is 2 : 3 and there are 40 tourists at the opening of a new museum, how many locals are at the opening?
66. A powdered drink mix calls for 3 scoops powder to 8 ounces water. How much powder do you need if you have 32 ounces of water?
67. It was recently estimated that uninsured vehicles outnumber insured ones by about six to five. If there are 2002 vehicles in a county, how many of them are uninsured?

68. One group (A) contains 125 people. One-fifth of the people in group A will be selected to win \$15.00 grocery cards. There is another group (B) in a nearby town that will receive the same number of grocery cards, but there are 585 people in that group.
- What will be the ratio of nonwinners in group A to nonwinners in group B after the selections are made?
  - What is the ratio of winners to people for group B?

## 4.1 PROJECT

### PROPORTIONS, PERCENTAGES, AND ELECTIONS

Our political system is based on a voting method called the plurality method. In the plurality method, voters are presented with a list of candidates and each voter selects their first-choice candidate. The choice with the greatest number of first place votes is declared the winner.

A small town decided to ask voters to do something slightly different during an election to fill a town council seat: they were asked to rank the four candidates in order of preference, from first to fourth. The following table, called a preference table, summarizes all of the votes that were cast during the election. For example, the first column shows that 540 voters picked Smith as their first choice, Thomas as their second choice, Orlando as their third choice, and Patel as their last choice.

**Preference Table for the Town Council Election**

	540	250	160	140
1st choice	Smith	Thomas	Patel	Orlando
2nd choice	Thomas	Patel	Thomas	Thomas
3rd choice	Orlando	Orlando	Orlando	Patel
4th choice	Patel	Smith	Smith	Smith

- Determine the total number of voters who participated in this election.
- How many voters chose Smith as their first choice? How many chose Smith as their last choice?
- What proportion of voters chose Smith as their first choice? What proportion of voters chose Smith as their last choice? Write each proportion as a fraction of the total number of voters, reduced to lowest terms.
- What percentage of voters chose Smith as their first choice? What percentage of voters chose Smith as their last choice? Round your answer to the nearest hundredth, if necessary.
- According to the plurality method, which candidate should be declared the winner?
- Considering the entire preference table, is there anything that strikes you as odd about the chosen winner?
- Is there a candidate that would be less polarizing?

**Solution**

In the last column of Table 4.2.2, we can see that, just as the police department claims, car break ins are decreasing by a larger percentage each year—20% the first year, 25% the second year. However, notice that the absolute reduction in the number of car break-ins remains exactly 2 fewer each year. In 2021, a reduction of 2 break-ins equates to a 20% decrease, but in 2022 a reduction of 2 break-ins is a 25% decrease. Even though the number of break-ins reduces by the same amount from year to year, the absolute difference of 2 becomes a larger percentage of the shrinking overall number of break-ins. In other words, the reference point changes each year, causing the percentage decrease from year to year to become larger. You'll need to decide for yourself the validity of the department's claims since they are correct in saying that break-ins decreased by a larger *percentage* in 2022, although the *number* of break-ins decreased by the same amount for both years.

As Example 4.2.9 illustrates, it is always wise to have an eye on the underlying numbers before comparing percentages so that you do not fall victim to shifting reference points. We like to assume that these types of percentage faux pas examples are done unintentionally in society. But one does wonder if the cynical phrase “you can make numbers say anything you want” originates from exactly these types of occurrences.

**Skill Check Answers**

1. \$1.50, \$2.00 2. \$52.80 3. \$228.79, \$233.19 4. 64% 5. 43.8%

## 4.2 Exercises

**✓ CONCEPT CHECK**

1. The price of an item as it is listed for public sale is the \_\_\_\_\_.
2. The \_\_\_\_\_ is the actual cost of an item after any discounts are subtracted.
3. One way to apply a 4% tax to an amount is to multiply the amount by \_\_\_\_\_.
4. The \_\_\_\_\_ between two amounts is the absolute value of the difference between the two numbers.
5. The percentage change between two amounts is equal to the absolute change divided by the \_\_\_\_\_.

 PRACTICE

Find the absolute change and the percentage change for each situation.

- |                              |                              |
|------------------------------|------------------------------|
| 6. 270 is increased to 1134  | 7. 14 is increased to 70     |
| 8. 150 is decreased to 39    | 9. 475 is decreased to 152   |
| 10. 39 is increased to 69.42 | 11. 62 is decreased to 42.78 |

 APPLICATIONS

Solve. Round your answer to the nearest hundredth, if necessary.

12. After taking an Uber where the bill came to \$27.50, you decide to tip the driver 10%. How much will the tip be?
13. You and a group of 5 friends dined at a restaurant. When bringing the bill, the server tells you that a 15% tip is included automatically for groups of 6 or more. If your pretax bill was \$112.40, how much was the tip?
14. Sofia's bill at the hair salon was \$85. If she wants to tip 20%, how much tip will she leave?
15. Jaylon and his friend had a pizza delivered, and the bill was \$24.60. Jaylon says they should tip the driver 15%; his friend says 10% is sufficient. How much more would the driver receive if they tip 15%?
16. Kyle is getting a tattoo tomorrow and the artist told him the total will be \$225. If Kyle decides to tip 20%, what amount will he tip?
17. Cheryl ordered grocery delivery after her hip surgery. If her grocery bill was \$132.70 and she wants to tip the delivery driver 10%, how much will the tip be?
18. Your dinner bill was \$18.00. If you leave a 20% tip, how much will the tip be?
19. If you wish to leave a 15% tip and your bill is \$9.50, how much tip will you leave?
20. A furniture store advertises 30% off all couches for their grand opening sale. What would be the sale price of a couch originally priced at \$849.00?
21. A local coffee shop offers a 5% discount if you bring your own reusable mug. What is the discounted price of a cup of coffee that is normally \$2.80?
22. While shopping for a used car, Cait receives competing offers from two dealerships. Dealer A offers a 10% discount on a \$11,900 car; Dealer B offers a 15% discount on a \$12,400 car. After the discount, which dealer's car costs less?

23. An online company is advertising a Presto Pizza Oven on sale for 45% off the original price of \$69.99. What is the sale price for the oven?
24. A furniture store is having an annual sale where everything is 20% off and is offering an additional 15% off to anyone who finances through a store credit card. If the couch you are interested in originally costs \$950, how much would you need to finance if you used the store credit card?
25. A power washing company has a package to power wash your house, patio, and driveway for \$780. The company placed an ad in the local newspaper with a 15% off coupon and will take an additional 5% off if you place a sign advertising the company in your front lawn for a week. How much would you pay for the power washing service if you use the coupon and place the sign in your front lawn?
26. A catering company charges \$1200 to cater a small company lunch. The catering company offers a 10% discount if the lunch is scheduled more than six weeks ahead of time and an additional 10% discount if the payment is paid in full at the time of scheduling. How much would the catered lunch cost if it was scheduled 8 weeks ahead of time and paid in full at the time of booking?
27. At a local optometrist, the regular price of a new pair of prescription sunglasses, including lenses and frames, is \$380. The optometrist is offering a 20% discount on sunglasses to new patients. If a new patient has vision insurance that covers 20% of the cost of eyewear after any discounts, how much will the patient pay for a pair of prescription sunglasses?
28. An artist is selling limited edition prints of select paintings from their latest gallery show. If you purchase a set of three prints, you can save 10% on the total price. People who purchased prints from the previous print release receive a discount code for an additional 15% off during a presale. If you plan to purchase a set of three prints for a total of \$350, how much would you pay if you made the purchase during the presale?
29. A shirt is on sale for 40% off, and you have an additional 20% off coupon. True or false: The shirt will ultimately be 60% off the original price?
30. Get Lucky is having a clearance sale of their winter items. All sale items are marked an additional 10% off the sale price. If a coat that originally costs \$110 is on sale for 25% off, what is the new sale price? Is this a reduction of 35% off the original price?
31. A ticket to see Pink in concert costs \$117.80 at regular price. An online ticket company is offering tickets at a 25% discount. Your friend bought a ticket at the discounted price but found out he can't go. He's offering the ticket to you at an additional 10% off what he paid. What price could you get the concert ticket for if you bought it from your friend?
32. The wholesale cost of a new sofa is \$240. The price of the sofa is marked up 40% before putting it on the showroom floor. During a showroom sale, the sofa was marked down 40%. What is the price of the sofa now?

33. The stock price for KTD was \$54.56 in January 2014. In February the stock had increased by 6% but in March the price fell by 6%. What was the price of KTD stock in March 2014?
34. Liza stays overnight in a hotel that charges 6% sales tax plus a 2% lodging tax in addition to the price of the room. If the room price was \$109, what was her total bill?
35. A local restaurant is required to add a 5.5% sales tax plus a 1.5% hospitality tax to each patron's bill. Ignoring tip, if a customer's pre-tax bill is \$32.62, what would be the total bill?
36. A new wireless printer costs \$99.99 in the store. What would your total cost be if sales tax is 9.5%?
37. You purchase a pair of jeans with a list price of \$175. If the sales tax is 8.5%, what is the total cost of the jeans? Round your answer to the nearest cent.
38. Jamie found a receipt for an MP3 player for \$127.59, tax included. If the sales tax rate was 9%, what was the selling price of the MP3 player? Round your answer to the nearest cent.
39. The local sales tax is 8%. If a pair of shoes sells for \$115, what is the total cost after tax?
40. Your total purchase at a department store is \$173.56. The local sales tax is 8.75%. How much will you pay if you have a 30% store coupon?
41. A local store is having a sale. All waterproof shoes are 40% off. If a pair of rain boots normally costs \$13.72 plus 7% sales tax, how much will it cost to buy the rain boots during the sale? (**Hint:** Discounts are applied before sales tax is added.)
42. A coffee and a Danish from a local café cost \$6.15 plus a 6.25% tax. How much would a person spend on a breakfast of coffee and Danishes if they purchased this meal twice a week for a year (52 weeks)?
43. Two movie tickets, a medium popcorn, and two drinks costs \$40.50 plus a 7.75% sales tax. If a couple attends a movie once a month for a year, how much would they spend on tickets and concessions?
44. To complete an outfit for an upcoming event, you purchase shoes online for \$119.95 and decide to also buy a pack of socks for \$15. The sales tax applied to the full purchase price is 6.2%. What is the total purchase price of the shoes and socks?
45. Four pavilion seating tickets to see the Cleveland Orchestra during a summer concert costs a total of \$343. During the check out process, you are asked whether you'd like to make a donation to the orchestra and decide to donate \$50. If the sales tax is 6.75% and the donation is not taxed, what is the total price for the four tickets and the donation?

46. In Louisiana, a pack of cigarettes costs about \$4.82 plus 4% sales tax. How much would a person spend on cigarettes in a year in Louisiana if he smoked one pack of cigarettes on each of the 365 days of the year?
47. You owe \$257.43 on your credit card. Because you have not paid your bill on time, you have to add a past due charge of \$25, an over limit fee of \$40, and a service charge of 9% of the amount owed on the credit card (without the past due charge and over limit fees). If you wish to send a check for the full amount immediately, how much should you write the check for?

Solve each problem. Round your answer to the nearest hundredth, if necessary. (**Hint:** Commission is a percent of the house's selling price that is added to the realtor's income.)

48. You are selling your house with a realtor who earns a 7% commission fee. If your house sells for \$185,000, how much commission will the realtor earn?
49. If you are selling your house with a local realtor who requires a 6% commission fee, what can you expect to pay the realtor if your house sells for \$139,000?
50. Suppose you sell your house for \$215,000 but still owe \$175,000 on the mortgage. If your real estate agent gets a 6% commission, what is the amount of money you'll make on this sale?
51. You are about to list your house as For Sale By Owner. Suppose you need to allow for a 3% commission for the buyer's realtor, and you need to receive a minimum of \$92,500 on the sale. What is the minimum price you can list the house at to accommodate both of these requirements? Round to the nearest hundred dollars.
52. If a laptop computer regularly costs \$879 and is on sale for \$599, what percentage discount is being given?
53. A poll in Russia looked at the support of Vladimir Putin's United Russia party. At that time, United Russia held 315 of the 450 seats in the State Duma, but the poll predicted this would fall to 252. If this was the case when the elections happened, calculate the percentage change in the number of seats held by the United Russia party.
54. Suppose that a local newspaper reported that Cityville and Beautytown both had 50 murders last year. However, 5 years ago, Cityville had 42 murders while Beautytown had just 29. Calculate the absolute change and the percentage change for each city over the five years. Could the newspaper make the claim that crime had gone up by the same amounts in each city? Explain.
55. The United States population was estimated to be 312,681,446 in 2011, estimated to be 285,102,075 in 2001, and estimated to be 77,584,000 in 1901. Calculate the absolute change and percentage change between each of the figures given (that is, 1901 to 2001, 1901 to 2011, and 2001 to 2011).

56. In 2020, a total of 23.6 million people tuned in to watch the Oscars. In 2021, the viewership of the rewards show fell by 56%. How many people watched the Oscars in 2021? Round your answer to the nearest tenth of a million.
57. For the 1998–1999 academic year, the average cost of attending a public in-state college was \$12,000. By the 2018–2019 academic year, the average cost of attending a public in-state college increased by approximately 78%. What was the average cost of attending a public in-state college during the 2018–2019 academic year?
58. If the Chevron Corp stock increased 2.44% from \$102.73, what was the absolute change in stock price? Round your answer to the nearest cent.
59. Over a week, the average price of gas decreased by 18% from \$2.65 per gallon. What was the absolute change in gas price? Round your answer to the nearest cent.
60. Two companies decreased overhead costs by 12% during the last year. Suppose Company A originally had an overhead cost of \$85,000 and Company B originally had an overhead cost of \$1,250,000. Do you believe the decrease in overhead costs between the two companies was the same? Justify your answer.
61. A news outlet reported that fifty million Americans visited online retail sites on Black Friday, representing an increase of 35 percent versus a year ago. How many Americans visited online retail sites on Black Friday last year?
62. If Apple stock fell 0.93% from \$363.57 per share, what was the absolute change in stock price?
63. Two companies report a 15% gain in online sales over the last year. Suppose Company Q had 25 online sales and Company Z had 150 online sales last year. Do you believe their growth was the same? Justify your answer.

 **WRITING & THINKING**

64. You decide to interview 9th graders from two different schools on whether they agreed with school dress codes or not. Your interview revealed that 18% of the 600 9th graders from Riverside High agree with the school dress code, and 30% of the 50 9th graders from Lakeview High agree. Is it fair to say that the number of 9th graders from Lakeview High who agree with the dress code is almost twice that of the number of 9th graders from Riverside High? Explain your reasoning.

The population of the United States changes continuously, with people being born, immigrating, emigrating, and dying every second. The chart above shows not the size of the population over time, but the rates at which the population was changing. Determine if the following statements are true or false. Explain.

- The US population had an annual increase of approximately 0.8% in 2010.
- The population of the US in 1970 was a little more than 120 million.
- The rate of change in the population of the US between 1990 and 1992 was  $\frac{1.39 - 1.13}{2}$ .
- The US population has been declining since the 1990s.

### Solution

- True. The chart gives the percentage increase for the US population for each year over the previous year. In 2010, the population grew by about 0.8% over 2009.
- False. The chart does not provide any information about the actual size of the US population at any point in history. However, the population growth was about 1.2% in 1970.
- False. The calculation shows the rate of change in the US population growth rate percentage, not the rate of change of the actual population.
- False. The US population increased in every year on the chart. It has just been increasing at a slower rate since 1990. For the population to be decreasing, the growth rate would need to drop below 0%.

Rate of change is a cornerstone of the branch of mathematics called differential calculus. It is the study of how quantities change from moment to moment and is used in disciplines such as physics, engineering, kinesiology, and economics, among many others.

### Skill Check Answers

1. \$1.60 per pound 2.  $\frac{1.5 \text{ L} \div 24}{24 \text{ hr} \div 24} = \frac{0.0625 \text{ L}}{1 \text{ hr}}$

## 4.3 Exercises

### ✓ CONCEPT CHECK

- A \_\_\_\_\_ is a fraction used to compare two quantities that are not necessarily in the same unit.
- When we compare things to a single unit, such as miles per gallon or cost per pound, it is referred to as a \_\_\_\_\_.
- The \_\_\_\_\_ of one quantity with respect to another is how much the first quantity changes for each unit change of the second quantity.

4. True or False: The ratios  $\frac{5 \text{ tacos}}{\$7}$  and  $\frac{\$7}{5 \text{ tacos}}$  both represent a local restaurant's advertisement of 5 tacos for \$7.
5. True or False: If a car has an advertised mileage rate of 20 mpg, that means it uses 20 gallons for every mile driven.

**PRACTICE**

Write each rate described.

6. An ad for a local vitamin and nutrition shop advertises that a certain brand of protein bar is on sale for \$38 per box of 18.
7. The price of tuition for a semester at an in-state university is \$4800 for 15 credit hours.
8. The cost of tuition at a local daycare center is \$1150 for 20 days of care per month.
9. Google Voice advertises its competitive price for international calling on mobile phones as 15 cents per minute from Mexico.
10. A freelance online editorial company offers document indexing for \$3.50 for 12 indexable printed pages.
11. The Department of Veterans Affairs offers tuition assistance for active military personnel under a new GI Bill that pays up to \$1473.00 per month for full-time status at a higher education institution.
12. The local grocery store offers 10 cans of tomato sauce for \$10 in the weekly sales ad.
13. Grayson needs to work 65 hours every three weeks to meet the quota for his school internship.

Write each rate described and then convert to a percentage. Round to the nearest tenth, if necessary.

14. In Parma, Ohio, for the May 4, 2021, primary elections, a total of 10,420 people voted out of 51,697 eligible voters in the city.
15. During the 2020 tax year, a tax return form indicates that a filer who earned \$32,750 paid \$3732 in federal taxes.
16. During the 2020 tax year, a tax return form indicates that the filer paid \$23,960 in federal taxes and earned a total of \$124,500.
17. For the 2019 enrollment period at Clemson University, a total of 3932 new freshman enrolled out of the 29,070 people who applied to the school.

Choose the correct from of the rate given.

18. Packs of noodle side dishes are on sale for \$5 when you purchase 4 packs.

a.  $\frac{\$4}{5 \text{ packs}}$

b.  $\frac{4 \text{ packs}}{\$5}$

c.  $\frac{\$5}{4 \text{ packs}}$

d.  $\frac{5 \text{ packs}}{\$4}$

19. Cooking instructions recommend roasting a 14-pound turkey for approximately 3 hours.

a.  $\frac{3 \text{ hours}}{14 \text{ pounds}}$

b.  $\frac{14 \text{ pounds}}{3 \text{ hours}}$

c.  $\frac{1 \text{ hour}}{14 \text{ pounds}}$

d.  $\frac{3 \text{ hours}}{1 \text{ pound}}$

20. To advertise their weekly special, Carol needs a sign made. One pen costs \$3.18, but she is going to offer 3 pens for the price of one. Which is the correct sign?

a. \$3.18/pen

b. 3 pens/\$3.18

c. \$9.54/3 pens

21. Tyson can run 4 km in 30 minutes.

a. 4 km/30 min

b. 7.5 km/min

c. 2 km/hour

d. 1 hour/2 km

### APPLICATIONS

Solve. Round your answer to the nearest hundredth, if necessary.

22. A patient in a hospital is prescribed IV fluids with a rate of 5 grams of sugar per 100 milliliters of water. If a patient is prescribed 1000 milliliters of fluids, how many grams of sugar will be delivered?

23. A patient in a hospital is prescribed IV fluids with a rate of 9 grams of sodium chloride per 1000 milliliters of water. If a patient is prescribed 1500 milliliters of fluids, how many grams of sodium chloride will be delivered?

24. A patient in a hospital is prescribed IV fluids with a rate of 4.5 grams of sodium chloride per 1000 milliliters of water. If a patient is prescribed 500 milliliters of fluids, how many grams of sodium chloride will be delivered?

25. To treat the water in a swimming pool, it is recommended to add 10 milliliters of chlorine per 1000 liters of water. How much chlorine is needed to treat the water in a pool that holds 34,000 liters?

26. Lucinda earns \$16.32 per hour working as a pharmacy technician. If Lucinda worked 171.5 hours last month, what was her gross pay for the month?
27. The average rainfall in Phoenix is 8.04 inches per year. If this average is maintained, how many inches of rain would Phoenix receive over 7 years?
28. The density of a cooking oil is 0.93 g/mL. By comparison, the density of water is approximately 1 g/mL. What is the mass of 1 cup of the oil? (Note that 1 cup is approximately 236.59 mL.)
29. The fastest speed recorded for English language typing is 216 words per minute. If the record holder maintains that rate for 11.5 minutes, how many words would be typed?
30. An SUV is advertised to have fuel tank capacity of 23 gallons and can travel 330 miles on a full tank of gas. Find the miles per gallon the SUV gets.
31. If your car can go 433 miles on a full tank of gas, find the miles per gallon your car gets if the tank holds 17.2 gallons.
32. You are planning to buy a mid-sized car and plan to factor fuel efficiency into your decision. Using the given information, decide which mid-sized car gets the best gas mileage.
- 2021 Honda Civic: 397 miles on 12.4 gallons
  - 2021 Mazda Mazda6: 476 miles on 16.4 gallons
  - 2021 Toyota Camry: 459 miles on 14.4 gallons
33. You want to buy a used truck and are interested in the fuel consumption rate for each of the three trucks you are considering. Using the information given, decide which of the used trucks gets the best gas mileage.
- 2008 Chevy Silverado: 500 miles on 29.4 gallons
  - 2006 Toyota Tundra: 428 miles on 26.4 gallons
  - 2007 Ford F-150: 250 miles on 15.6 gallons
34. Two competing stores sent out fliers for back-to-school sales and listed similar items for sale. Use unit prices to decide which store to buy each item from if you need to purchase all of the items listed.

Price Comparison		
Item	Closeout Closet	Discount Dollar
Mechanical Pencils	8 for \$2.39	10 for \$2.64
Pens	10 for \$1.49	10 for \$1.57
Notebooks	3 for \$4.99	5 for \$9.99
Wide-Ruled Paper	3 for \$2.50	4 for \$3.00

35. It costs \$130.11 per week to rent a standard-size car in Nashville, TN. Find the price per day it costs to rent this car.

36. It costs \$2.01 to drive 25 miles in a new 2012 Hybrid car. How much does it cost per mile to drive 25 miles?
37. It costs \$4.78 to drive 25 miles in a 2012 sedan. How much does it cost per mile to drive 25 miles?
38. Ron gets paid \$51,630 per year. If he works 2087 hours in a year, find his hourly rate of pay.
39. If a 4-pound bag of sugar costs \$2.99, what is the unit cost for a pound of sugar?
40. The advertised special is \$9.99 for 16 ounces of frozen shrimp. Find the unit cost of the shrimp.
41. Eggplants are 4 for \$5.00. What is the cost per eggplant? How much eggplant do you get per dollar?

Use the following table of exchange rates for Exercises 42–43.

US Dollar Exchange Rates		
US Dollar (USD)	Units per USD	USD per Unit
British Pound (GBP)	0.711576	1.405332
Indian Rupee (INR)	73.669595	0.013574
Australian Dollar (AUD)	1.294470	0.772517
Canadian Dollar (CAD)	1.212872	0.824489
Japanese Yen (JPY)	109.642453	0.009121

42. Use the table to answer the following questions.
- What is the unit exchange rate of US dollars to British Pounds?
  - What is the unit exchange rate of British Pounds to US dollars?
  - If a pair of shoes costs 75 US dollars, approximately how many British Pounds do the shoes cost?
43. Use the table to answer the following questions.
- What is the unit exchange rate of US dollars to Japanese Yen?
  - What is the unit exchange rate of Japanese Yen to US dollars?
  - If a comic books costs 500 Japanese Yen, approximately how many US Dollars does the comic book cost?

44. The projected velocity of a space shuttle during its first three minutes in the air is given below.

Time (s)	Altitude (m)	Velocity (m/s)
0	-8	0
20	1244	139
40	5377	298
60	11,617	433
80	19,872	685
100	31,412	1026
120	44,726	1279
140	57,396	1373
160	67,893	1490
180	77,485	1634

- What is the space shuttle's acceleration during the first 20 seconds?
  - Does the space shuttle accelerate more between 20–40 seconds or between 120–140 seconds?
45. The civilian unemployment rate as determined by the US Bureau of Labor Statistics<sup>4</sup> is shown for 2002–2021.

**Civilian unemployment rate, seasonally adjusted**

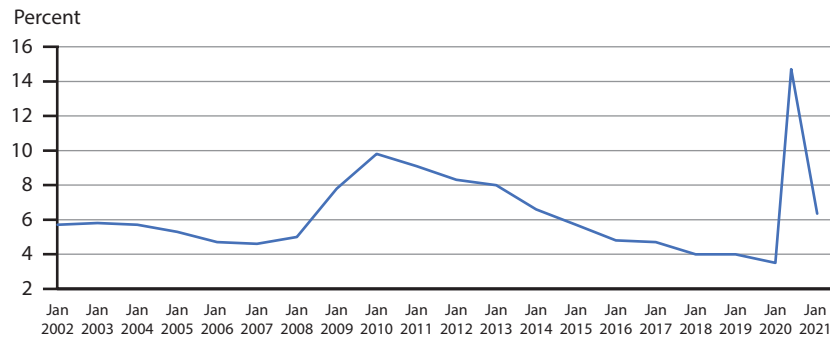

- When was the unemployment rate the highest?
- What is the average rate of change from January 2012 to January 2016?
- Are there any intervals where the unemployment rate is not changing?
- What interval has the steepest decline?

<sup>4</sup> Source: "Civilian unemployment rate," Bureau of Labor Statistics, accessed December 8, 2021, <https://www.bls.gov/charts/employment-situation/civilian-unemployment-rate.htm>.

46. The Consumer Price Index,<sup>5</sup> which is “a measure of the average change over time in the prices paid by urban consumers for a market basket of consumer goods and services,” is shown for May 2007 to May 2021.

**Consumer Price Index, May 2007-May 2021**

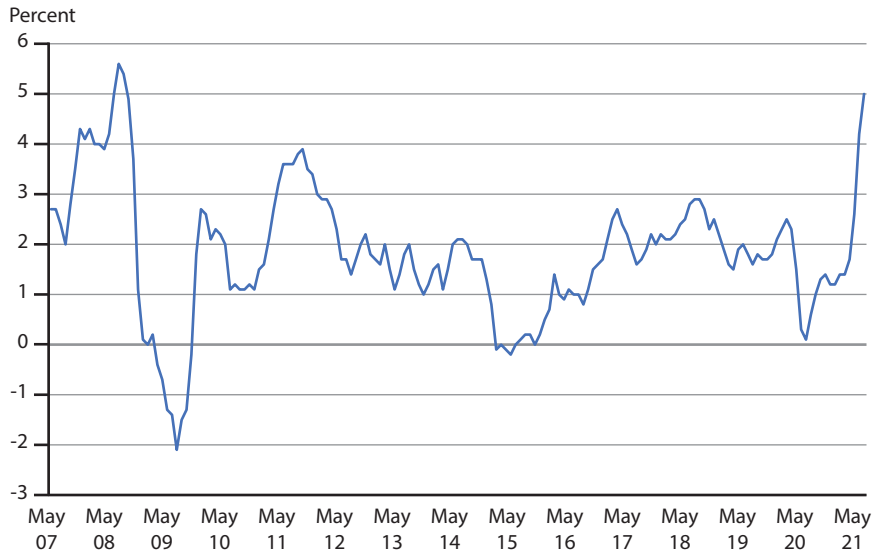

- a. When was the Consumer Price Index the lowest?
- b. What is the average rate of change from May 2015 to May 2020?
- c. Are there any intervals where the Consumer Price Index appears to have no change over time?
- d. What interval has the steepest decline?

<sup>5</sup> Source: “Consumer prices increase 5.0 percent for the year ended May 2021,” Bureau of Labor Statistics, accessed December 8, 2021, <https://www.bls.gov/opub/ted/2021/consumer-prices-increase-5-0-percent-for-the-year-ended-may-2021.htm>.



10. Diet Coke contains approximately 31 milligrams of caffeine per cup. Determine how many milligrams per fluid ounce this is.
11. Barbecue potato chips contain 150 calories per ounce. Determine how many calories per pound this is.
12. All-purpose flour costs \$0.99 per pound. What is the price of flour per kilogram?
13. A hardware store loans out toolsets at a rate of \$5 per hour. Determine how much tool rental costs per day.
14. A water faucet left running can use 900 liters of water per hour. Determine how many gallons per hour this is.
15. A machine uses 0.5 gallons of fuel per hour. Determine how many liters per hour this is.
16. A road sign indicates that the speed is 50 miles per hour. What is the speed in kilometers per hour?
17. A road sign indicates that the speed is 100 kilometers per hour. What is the speed in miles per hour?
18. Hair grows at an average rate of 0.5 inches per month. What is the average growth rate of hair in centimeters per month?
19. For the first 30 years of its lifespan, a dawn redwood tree grows an average of 1.22 meters per year. Determine the growth rate of the tree in centimeters per year.
20. Guidelines recommend that paper lawn bags contain no more than 50 pounds of material per bag. Determine the recommended capacity in kilograms per bag.
21. According to an EPA study, the average American produces 4.5 pounds of trash per day. How many ounces of trash per day does the average American produce?
22. A motorcycle gets an average fuel efficiency of 25 km/L. Determine the fuel efficiency in miles per gallon.
23. An SUV gets an average fuel efficiency of 14 mi/gal. Determine the fuel efficiency in kilometers per liter.
24. The maximum speed of a housefly is 5 miles per hour. Determine the speed in kilometers per minute.
25. The average speed of a tree swallow is 20 miles per hour. Determine the speed in kilometers per minute.

26. Lumber varies in weight depending on the type of tree it is made from. A 2 x 6 Sitka Spruce lumber has a weight of 1.6 pounds per linear foot. Determine the weight in ounces per yard.
27. A pool is losing water at a rate of 3 fluid ounces per hour. Determine the rate of water loss in cups per day.
28. A small mill can process wood chips into sawdust at a rate of 75 kilograms per hour. Determine the rate in pounds per day.
29. A water faucet left running can use 240 gallons of water per hour. Determine this rate in liters per minute.
30. A pedometer is a device that records the number of steps taken, and many watches can measure this as well. Assuming a consistent walking pace, convert the following into steps per minute.
- Walking 4 miles per hour with a stride length of 2100 steps in a mile
  - Walking 2.75 miles per hour with a stride length of 1920 steps in a mile
  - Walking 3.25 miles per hour with a stride length of 2005 steps in a mile
31. Tenisha makes jewelry and sells it via an online craft site. For each of the following scenarios, express Tenisha's earnings in dollars per hour.
- Making 3 bracelets in 50 minutes and selling them for \$15 each.
  - Making 2 necklaces in 105 minutes and selling them for \$22 each.
  - Making 1 pair of earrings in 17 minutes and selling them for \$13 each.
32. Convert the following fuel consumption measurements from miles per gallon to kilometers per liter. Use 1 mile is approximately 1.609 kilometers and 1 gallon is approximately 3.785 liters.
- 28 miles per gallon
  - 21 miles per gallon
  - 32.5 miles per gallon
33. Recall from Example 4.4.4 that the drip factor for a liquid administered through an IV is given in gtt/mL. The flow rate of an IV is measured in gtt/min. For each of the following situations, determine how many drops per minute (in whole numbers) should be given.
- 300 mL given over 2 hours with a drip factor of 20 gtt/mL
  - 90 mL given over 0.5 hours with a drip factor of 15 gtt/mL
  - 1200 mL given over 10 hours with a drip factor of 20 gtt/mL
34. In 1628 the Swedish warship Vasa sank less than a mile into its first voyage. One factor may have been the use of different rulers during construction, with some calibrated to Swedish feet which had 12 inches and some calibrated to Amsterdam feet which had 11 inches. If the Vasa was 69 meters long, find the ship's length in Swedish feet and Amsterdam feet. Let 1 meter equal 39.37 inches.

35. After NASA's Hubble telescope first launched in 1990, the pictures it took were fuzzier than expected. The cause was an error in the shape of the telescope's main mirror: it was 2.2 microns too flat. If a micron is  $1/1000$  of a millimeter and 1 millimeter is approximately 0.03937 inches, how large was the error in inches?
36. The day before the start of the 2014 Sochi Winter Olympics, an error was discovered in the biathlon track. The loop was supposed to be 2.5 kilometers but was 40 meters too short. If an athlete completed 3 loops on the erroneous track, how many feet short was their distance? Use 1 meter is approximately 3.281 feet.

## 4.4 PROJECT

### LITERS, GALLONS, AND FUEL EFFICIENCY

According to a 2019 report produced by the United Nations, fossil fuel emissions from energy use grew 2.0% in 2018. These emissions reached a record high of 37.5 gigatons of equivalent  $\text{CO}_2$  per year. In order to try to alleviate the issue, many countries are working on requiring that cars become more fuel efficient.

In this activity, you will investigate a few different units used to measure fuel efficiency and how to compare such units.

In the US, we define fuel efficiency as the number of miles a car can travel using one gallon of fuel. The unit of choice for this measurement is miles per gallon (mpg). This number is the rate of miles traveled per gallons used. European countries commonly define fuel efficiency as the amount of fuel a car requires to travel a fixed distance. The unit of choice for this measurement is liters per 100 kilometers  $\left(\frac{\text{L}}{100 \text{ km}}\right)$ . This number is the rate of liters of fuel used per 100 kilometers traveled. Notice that mpg is a rate of distance per volume of fuel while  $\frac{\text{L}}{100 \text{ km}}$  is a rate of volume of fuel per distance.

The 2021 Honda Accord has a reported highway fuel efficiency of 38 mpg. Complete the following steps to find the Accord's equivalent highway fuel efficiency in the European standard of  $\frac{\text{L}}{100 \text{ km}}$ .

Recall that 1 US gallon is equal to 3.785 liters and that 1 mile is approximately equal to 1.61 kilometers.

- Determine how many 100 kilometers are in 38 miles. Round your answer to the nearest hundredth, if necessary. (**Hint:** Find the number of kilometers in 38 miles and divide your answer by 100.)
- Organize this information using the table below.

<b>Distance</b>	Miles	38
	100 Kilometers	
<b>Fuel Volume</b>	Gallons	1
	Liters	

Heights of Traffic Cone Stacks:

$$h = c(1.5) + 16.5$$

In this equation,  $h$  = height in inches of the stack and  $c$  = number of cones in the stack.

Two things to note here. First, looking at the graph, if we extend the line, it no longer intersects the origin as it should for proportional relationships. Second, the equation does not adhere to the correct form. The extra 16.5 shatters the form of  $y = kx$  necessary for a proportional equation.

---

### Skill Check Answers

1. c. and d. 2. a. and b. 3. \$6.02

## 4.5 Exercises

### ✓ CONCEPT CHECK

1. A variable quantity  $A$  is \_\_\_\_\_ to a variable quantity  $b$  when there exists an invariant,  $k$  (the constant of proportionality), such that  $A = kb$ .
2. The length of a spring will always be proportional to the \_\_\_\_\_ on the spring.
3. Setting two equivalent fractions equal to one another and solving is often referred to as \_\_\_\_\_.
4. When two quantities are proportional, they are connected by an \_\_\_\_\_ formula.
5. If a relationship is proportional, the graph of the corresponding values will be a line that passes through the \_\_\_\_\_, and the slope of that line is the constant of proportionality.

### 💡 PRACTICE

Find the constant of proportionality.

6.  $3y = 12x$

7.  $7a = 35b$

8.  $4r = 36s$

9.  $5h = 55w$

Solve.

10. A force of 500 newtons stretches a spring by 2 meters.
  - a. What is the constant of proportionality?
  - b. How much force would be needed to stretch the spring 5 meters?
11. A force of 70 newtons stretches a spring by 5 meters.
  - a. What is the constant of proportionality?
  - b. How long would the spring stretch if a force of 42 newtons was used?
12. A force of 240 newtons stretches a spring by 4 meters.
  - a. What is the constant of proportionality?
  - b. How much force would be needed to stretch the spring 7.5 meters?
13. A force of 125 newtons stretches a spring 5 meters.
  - a. What is the constant of proportionality?
  - b. How long would the spring stretch if a force of 225 newtons was used?

#### APPLICATIONS

14. If a model car is an S scale model car, then for every 1-inch length on the model, the corresponding part of the actual car is 64 inches long. Find the constant of proportionality for the length of the scale model to the length of the actual car.
15. On a map for a local community park, the scale indicates that every inch of length on the map corresponds to 48 inches of length of the park. Find the constant of proportionality for the scale of the map to the actual park.
16. The scale on a map of a town center indicates that one inch on the map is equivalent to 60 inches in the town center. Find the constant of proportionality for the length on the map to the length in the town center.
17. For an HO scale model train, each inch of length of the on the model train corresponds to 87 inches on the actual train. Find the constant of proportionality for the length on the model train to the length on the actual train.
18. The scale given on a blueprint of a city park indicates that each inch on the blueprint is equivalent to 8 feet of the actual park. If a path in the park is 160 feet long, how long is the path on the blueprint?
19. For a G scale model train, each inch of length of the model train is equivalent to 25 inches of length on the actual train. If a real boxcar is 665 inches long, how long is the G scale model of the boxcar?
20. At Minimumdus, an outdoor museum in Klagenfurt, Austria, each building replica is a scaled version of the original with a ratio of 1 : 25. If the actual Taj Mahal is 73 meters tall, how tall is the replica at Minimumdus?

21. A Cuda Dragster car model has a scale of 1 : 25. If the tire height of the model is 1.06 inches, what is the height of the life-size tire?
22. The Clarksville football team outscored its opponents 5 : 3 last season. If their opponents scored 78 points, how many points did Clarksville score?
23. The scale of a map is 1 in. = 11.9 miles. How many inches will be drawn on the map to represent 30.9 miles?
24. Find the actual width of a building if the model of the building is 5 cm wide by 58.7 cm long and the actual length of the building is 140.9 m.
25. The ratio of outdoor swimmers to indoor swimmers at the recreation center is 3 : 2. If the center has 55 swimmers altogether, how many of them are indoor swimmers?
26. On a globe model of the Earth, one centimeter is equivalent to 650 kilometers on the actual Earth. The straight-line distance from Juneau, AK, to Orlando, FL, is approximately 5215 kilometers. What would the distance between the two cities be on the globe model?
27. You are packing to move and need to pack your collection of paperback novels. The moving company you hired requires that small boxes weigh no more than 45 pounds. You weigh a few of your books and determine that 4 novels weigh approximately 3.6 pounds. If you have 125 novels, approximately how many boxes will you fill with books?
28. A contest is being held to guess the number of candies in a jar where the winner will receive a \$50 gift card. You make an educated guess that the jar holds 17 ounces of candy and experiment with a pack of candy you purchased yourself to determine that 20 individual candies weigh 0.15 ounces. Using this information, how many candies would you guess are in the jar?
29. A wedding planner is assembling small gift bags for an upcoming wedding reception. The couple set aside \$240 of their wedding budget for the gifts, \$120 of which is specifically for chocolates. The planner found chocolate hearts that are sold in packs of 8 for \$2.50 per pack. How many chocolate hearts can the wedding planner purchase for the gift bags?
30. A general goods store at a campsite needs to restock their inventory of fire starters. The store's distributor sells boxes of 12 fire starter kits for \$16. If the store's budget for ordering fire starters is \$260, how many fire starter kits can be purchased? (**Hint:** You can only purchase whole boxes.)
31. While packing up donations for distribution, a worker at a donation center forgot to write the number of T-shirts that were packed into a box before sealing it with tape. Instead of unpacking the box, the worker weighed a few T-shirts and discovered that a stack of four T-shirts weighs an average of 550 grams. The worker also estimates that the weight of the contents of the box is 16 550 grams. Approximately how many T-shirts are in the box?

32. A local food bank received a shipment of 3 large boxes each containing 12-count individual mac and cheese dinners. Employees determine that each of the 12-count dinner boxes weighs 25 pounds and each of the large boxes weighs 100 pounds. How many individual dinners were received?
33. A coffee roasting company offers a blend made of coffee beans from Brazil, Colombia, and Peru in a ratio of 4 : 5 : 2. The company pays \$3.50/lb for the beans from Brazil, \$4.00/lb for the beans from Colombia, and \$4.50/lb for the beans from Peru. If the production steps (such as roasting, packaging, and shipping), cost the company an additional \$3.00 per pound, what is the total cost of producing one pound of the coffee blend?
34. Instructions for a chemical procedure state to mix salt, baking soda, and water in a 4 : 5 : 21 ratio by mass. How many grams of water would be required to make a mixture that contains 60 grams of salt?
35. A screen printing company finds that for each T-shirt it produces, 40% of the cost is for materials, 50% is for labor, and 10% is for advertising. If a batch of 100 shirts required \$180 in materials, what was the total cost of producing one shirt in the batch?
36. You want to estimate the number of sheets of office paper that you have on your desk. You know the following.
1. The standard pack of paper contains 500 sheets and is 52 millimeters high.
  2. The height of the stack you have is 20 millimeters.
- Use the fact that the height of a stack is proportional to the number of sheets of paper in it to find the number of sheets in your stack.
37. You need to determine how many cans a machine can produce in half an hour. You know that the average amount of cans produced in a 6-hour shift is 3000. Use the fact that the number of cans produced is proportional to time to find the number of cans that is produced in half an hour.
38. The following table contains the amount of simple interest paid on a loan in relation to the length of the loan.

<b>Length of the Loan (years)</b>	1	2	3	4	5	6
<b>Interest (\$)</b>	70	140	210	280	350	420

Is the interest proportional to the length of the loan? If it is, find the constant of proportionality. If not, explain why.

39. The following table contains the amount of simple interest paid on a loan in relation to the length of the loan.

<b>Length of the Loan (years)</b>	1	2	3	4	5	6
<b>Interest (\$)</b>	308.39	635.80	983.40	1352.45	1744.25	2160.22

Is the interest proportional to the length of the loan? If it is, find the constant of proportionality. If not, explain why.

40. Consider the distance covered by a car moving at a constant speed.

<b>Time (minutes)</b>	3	5	10	15	20
<b>Distance (miles)</b>	2.4	4	8	12	16

Is the distance proportional to the time spent? If it is, find the constant of proportionality. If not, explain why.

41. Consider the weight of a bottle of milk in relation on the amount of milk in the bottle.

<b>Amount of Milk (milliliters)</b>	300	400	550	750
<b>Weight (grams)</b>	800	900	1050	1250

Is the amount of milk proportional to the weight of the bottle? If it is, find the constant of proportionality. If not, explain why.

42. The air temperature in Anchorage, Alaska, during a day in 2022 is shown in the table.

<b>Hours after Midnight</b>	3	6	9	12	15
<b>Temperature (°C)</b>	1	2	3	5	6

Is the temperature proportional to the number of hours passed after midnight? If it is, find the constant of proportionality. If not, explain why.

43. The table shows the amount of flour needed to make a loaf of bread.

<b>Flour (grams)</b>	400	1200	1600	2800
<b>Bread (loafs)</b>	1	3	4	7

Is the amount of flour proportional to the number of loafs of bread baked? If it is, find the constant of proportionality. If not, explain why.

44. The growth of a child during the first 6 months of life is shown in the following table.

<b>Age (months)</b>	1	2	3	4	5	6
<b>Height (centimeters)</b>	55	58	61	64	67	70

Is the height of the child proportional to the age of the child? If it is, find the constant of proportionality. If not, explain why.

45. The temperature of water heated over a span of 8 minutes is shown in the table.

<b>Time (minutes)</b>	1	2	4	6	8
<b>Temperature (°C)</b>	30	40	60	80	100

Is the temperature of the water proportional to the time it was heated? If it is, find the constant of proportionality. If not, explain why.

46. The following table shows the amount of water needed to fill a cylindrical tank depending on the tank's diameter.

<b>Diameter (meters)</b>	1	2	3	4	5
<b>Volume of Water (liters)</b>	1570	6280	14,140	25,130	39,270

Is the volume proportional to the diameter of the tank? If it is, find the constant of proportionality. If not, explain why.

## 4.5 PROJECT

### WHY ARE CELLS SO SMALL?

The germ theory of disease is the fundamental theory of medicine that says infectious diseases are caused by microscopic organisms called pathogens. The theory wasn't accepted until the end of the 19th century, in part because pathogens are invisible to the naked eye.

A main type of pathogen is bacteria (singular, bacterium). These are one-celled (or unicellular) living organisms present almost everywhere on Earth.

In this project, we will explore one possible reason that bacteria are so small.

In order to simplify matters, let's assume we are going to study a bacterium that is perfectly spherical.

Biologists believe that the ability of a bacterium to obtain resources (such as food) is proportional to its radius. They also believe that the bacterium's need (or demand) for resources is proportional to the square of its radius. If the demand for resources is less than or equal to the ability to obtain resources, then the bacterium is able to sustain itself.

The table below contains the values for the ability to obtain resources ( $A$ ) and the demand for resources ( $D$ ) for a hypothetical bacterium. Units are omitted for clarity.

<b>Radius (<math>R</math>)</b>	<b>Ability (<math>A</math>)</b>	<b>Radius Squared (<math>R^2</math>)</b>	<b>Demand (<math>D</math>)</b>
1.5	0.75	2.25	0.45
2	1	4	0.8
2.5	1.25	6.25	1.25

1. Assume that  $A$  is proportional to  $R$ ; that is,  $A = k_1R$  for a constant of proportionality  $k_1$ . Determine the value of  $k_1$ .
2. Assume that  $D$  is proportional to  $R^2$ ; that is,  $D = k_2R^2$  for a constant of proportionality  $k_2$ . Determine the value of  $k_2$ .
3. When the radius doubles from 1.5 to 3.0, how many times does the ability to obtain resources increase by?
4. Determine the demand ( $D$ ) from a radius of  $r = 3$ . How many times larger is that than the demand ( $D$ ) when the radius is equal to 1.5?
5. How can these numbers help explain why most unicellular organisms are usually small?

## 5.1 Exercises

### ✓ CONCEPT CHECK

1. Linear equations are equations where the variable has an exponent of \_\_\_\_.
2. The value of the \_\_\_\_\_ variable changes with respect to the value of the \_\_\_\_\_ variable.
3. When any number makes an equation true, the equation has \_\_\_\_\_ solutions.
4. When solving a formula for a specific variable, treat the variables as if they are \_\_\_\_\_.
5. A function is a set of \_\_\_\_\_ where each value of the dependent variable is associated with a unique independent variable.

### 💡 PRACTICE

Solve each equation for the variable.

6.  $4 = -6w$

7.  $\frac{-7}{4}x = -2$

8.  $-2(4v + 4) = -8v + 7$

9.  $z + 0.2z - 3.6 = 5.8(z - 3)$

10.  $2(x + 5) - 2 = 4(x + 2) - 2x$

11.  $3.2x - 1 = 2(1.6x + 1)$

12.  $3(x + 2) - 1.2 = 1.2x + 4.8 + 1.8x$

13.  $10.3z - 9.3z - 5.4 = 5.5$

14.  $\frac{4}{y} = \frac{4}{y-1}$

15.  $\frac{y-1}{6} = \frac{y+1}{3}$

16.  $\frac{x-10}{10} = \frac{x-7}{8}$

17.  $\frac{1}{2} = \frac{x-1}{2x-2}$

Solve each formula for the indicated variable.

18. Solve  $P = R - C$  for  $C$ .

19. Solve  $v = k + gt$  for  $k$ .

20. Solve  $L = 2\pi rh$  for  $r$ .

21. Solve  $I = Prt$  for  $r$ .

22. Solve  $A = \frac{1}{2}bh$  for  $h$ .

23. Solve  $V = \pi r^2 h$  for  $h$ .

Evaluate each function for the given value. Round your answer to the nearest hundredth, if necessary.

24. Find  $f(7)$  for  $f(x) = x^3 - 12$ .

25. Find  $f(-2)$  for  $f(t) = t^3 + 5$ .

26. Find  $f(10)$  for  $f(x) = x^2 - 2x + 3$ .

27. Find  $f(9)$  for  $f(t) = t^2 + 100t - 125$ .

28. Find  $f(5)$  for  $f(x) = \begin{cases} 2x, & x < 0 \\ x + 7, & x \geq 0 \end{cases}$ .

29. Find  $f(1.5)$  for  $f(t) = \begin{cases} 15 - 2t, & t \leq 5 \\ 8t - 5, & t > 5 \end{cases}$ .

30. Find  $f\left(\frac{1}{3}\right)$  for  $f(x) = \log 3x$ .

31. Find  $f(4)$  for  $f(x) = \log 3x$ .

32. Use your knowledge of real numbers to determine how their properties limit the domain and range of the function  $f(x) = \sqrt{x+7}$ .

33. Use your knowledge of real numbers to determine how their properties limit the domain and range of the function  $f(x) = 2x^2 + 5$ .

### APPLICATIONS

Solve. Round your answer to the nearest hundredth, if necessary.

34. When setting up a store front in an online marketplace, the seller needs to pay a base fee of \$15 for the website space and \$0.50 per item listed. A seller wants to spend no more than \$40 to list items in the online store. Solve the equation  $\$40 = \$15 + \$0.50x$  for  $x$  to determine the maximum number of items the seller can list.

35. A carnival costs \$20 to enter and each carnival game costs \$1.50 to play. Sam wants to win a stuffed animal for his date, but only wants to spend a total of \$50 on non-food purchases. Solve the equation  $\$50 = \$20 + \$1.50x$  for  $x$  to determine how many attempts he can make at winning his date a stuffed animal.
36. The Reynold's want to build a decorative fence around their vegetable garden. A garden fence needs to be 72 inches tall to keep out deer. They select a solid base frame that is 24 inches tall and a mesh fence with 2-inch squares for the top of the fence. Determine how many squares high the mesh needs to be by solving the equation  $72 = 24 + 2x$  for  $x$ .
37. The Geology department is raising money for scholarships by hosting the annual Sedimental Evening Dinner. The music department provides free entertainment, and the hospitality management department hosts as part of student course requirements. The department would like to raise \$3000 for scholarship and will spend \$760 on food and decorations. The dining hall can accommodate 80 guests. Solve the equation  $\$3000 = 80x - \$760$  to determine the price the department should charge per guest.
38. Suppose corn chips cost 22.5 cents per ounce. Use the given equation to determine how many ounces are in the bag of chips if a bag costs \$3.03.

$$\frac{\$0.225}{1 \text{ oz}} = \frac{\$3.03}{x \text{ oz}}$$

39. Suppose cereal cost 24.5 cents per ounce. Use the given equation to determine the cost of a box of cereal if a bag contains 20 oz.

$$\frac{\$0.245}{1 \text{ oz}} = \frac{\$x}{20 \text{ oz}}$$

40. An entry level civil engineer's annual pay is \$62,348 based on 52 weeks per year. Due to the economy, his company is having to cut back on the number of weeks that it employs its civil engineers. The firm plans on cutting the work year to 49 weeks and keep the same rate of pay. Use the given equation to determine how much should the civil engineer expect his annual pay to decrease. Round your answer to the nearest dollar.

$$\frac{\$62,348}{52 \text{ weeks}} = \frac{\$x}{49 \text{ weeks}}$$

41. You're making dessert, but your recipe needs adjustment. Your peanut butter cookie recipe makes 4 dozen cookies, but you need 1 dozen cookies. The recipe requires  $1\frac{1}{2}$  cups of butter, 3 teaspoons of almond extract, and  $2\frac{1}{2}$  cups of peanuts. Use the given equations to determine how much of each of these ingredients are necessary for 1 dozen cookies. Simplify your answer.

a. butter:  $\frac{1\frac{1}{2} \text{ cups}}{4 \text{ dozen}} = \frac{x}{1 \text{ dozen}}$

b. almond extract:  $\frac{3 \text{ teaspoons}}{4 \text{ dozen}} = \frac{x}{1 \text{ dozen}}$

c. peanuts:  $\frac{2\frac{1}{2} \text{ cups}}{4 \text{ dozen}} = \frac{x}{1 \text{ dozen}}$

42. In business, profit for producing and selling an item is modeled by the equation  $P = R - C$ , where  $P$  is the profit earned,  $R$  is the revenue earned from sales, and  $C$  is the cost to produce the item. Find the revenue earned by the company if they made a profit of \$3.2 million and incurred a cost of \$1.8 million.

43. The distance traveled by an object can be described by  $d = rt$ , where  $r$  is the objects rate (or speed) and  $t$  is the amount of time the object traveled. If you need to drive a distance of 105 miles and can travel at an average speed of 60 miles per hour, how many hours will the trip take?

44. The following graph displays the change in air temperature over the last three days. Determine if the following statements about the graph are true or false. If false, explain why.

- a. The graph of Day 2 has a domain between  $-4$  and  $11$ , inclusive.
- b. The graph of Day 1 and the graph of Day 3 have the same range.
- c. The range of Day 3's graph is a subset of the combined range of Day 1's graph and Day 2's graph.

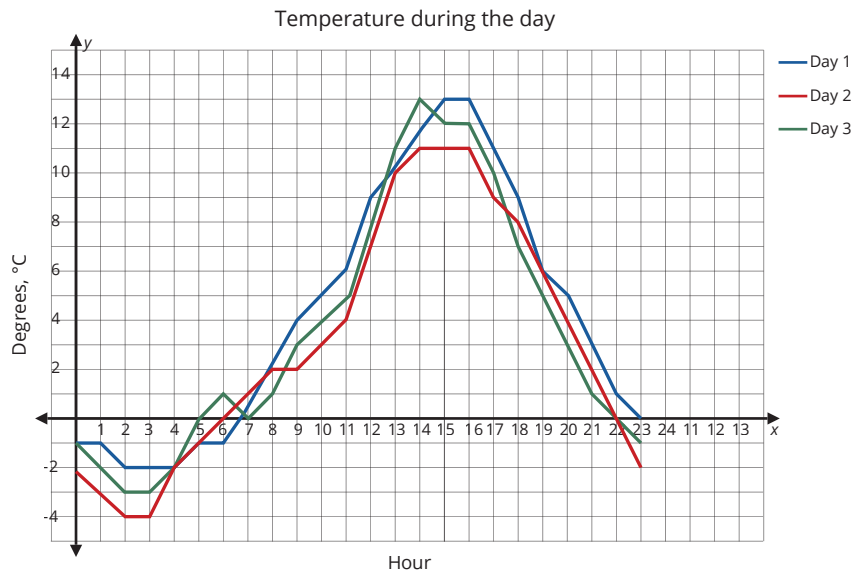

45. The following graph shows the number of items (in thousands) produced by a factory each year from 2018 to 2020. Determine if the following statements about the graph are true or false. If false, explain why.
- The ranges of all three graphs are the same.
  - The domains of all three graphs are the same.
  - The range of the 2019 graph is a subset of the range of the 2020 graph.

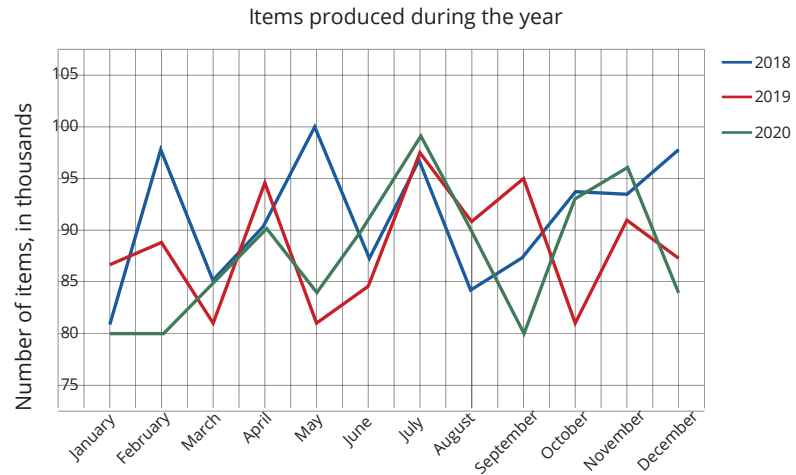

46. The function  $M$  represents the number of a specific model of car manufactured by an automotive company in the year 2022 based on sales of that model car in the year 2021. What can you say about the domain and range of the function  $M$ ?
47. The function  $C$  represents the cost of a wedding reception where the price to rent the venue is \$7000 and the price of food and decorations depends on the number of people attending. The venue has a maximum capacity of 150 guests. What can you say about the domain and range of the function  $C$ ?



### WRITING & THINKING

48. Consider the function  $f(x) = x^2$ .
- Describe the domain and range of the function  $f$ .
  - Explain how the range would be affected if the domain was restricted to nonnegative real numbers.
  - Explain how the range would be affected if the domain was restricted to integers.

## 5.2 Exercises

### ✓ CONCEPT CHECK

- The \_\_\_\_\_ of a line is the ratio of the change in  $y$ -values to the change in  $x$ -values.
- The \_\_\_\_\_ form of an equation is  $y - y_1 = m(x - x_1)$ .
- The \_\_\_\_\_ form of an equation is  $y = mx + b$ .
- \_\_\_\_\_ lines have slopes that are negative reciprocals of each other.
- \_\_\_\_\_ lines have slopes that are equal to each other.

### 💡 PRACTICE

Find the slope of the line determined by each pair of points.

- |                      |  |
|----------------------|--|
| 6. $(8, -3), (5, 9)$ | 7. $(9, -2), (11, -2)$                   |
| 8. $(8, 3), (8, -3)$ | 9. $(1, 1), \left(2, \frac{3}{2}\right)$ |

Find the slope and  $y$ -intercept of each linear equation.

- |                    |                   |
|--------------------|-------------------|
| 10. $y = 2x - 7$   | 11. $y = -4x$     |
| 12. $2x + 4y = -5$ | 13. $-x + 2y = 3$ |
| 14. $y = 7$        | 15. $x = 10$      |

Find the slope-intercept form of the equation for the line passing through each pair of points.

- |  |                                    |
|--|------------------------------------|
| 16. $(12, 83)$ and $(9, 59)$   | 17. $(-8, 76)$ and $(17, -74)$ .   |
| 18. $\left(-\frac{5}{4}, -\frac{13}{4}\right)$ and $\left(\frac{5}{3}, -\frac{23}{6}\right)$ | 19. $(5.5, 45)$ and $(-10, -85.2)$ |

- Identify the slope and  $y$ -intercept, along with another point on the line  $14x - 2y = 64$ , given that  $y = 7x - 32$  and  $y - 24 = 7(x - 8)$  are equivalent equations.
- Identify the slope and  $y$ -intercept, along with another point on the line  $5x + 4y = 18$ , given that  $y = -\frac{5x}{4} + \frac{9}{2}$  and  $y - \frac{5}{4} = -\frac{5}{4}\left(x - \frac{13}{5}\right)$  are equivalent equations.

22. Identify the slope and  $y$ -intercept, along with another point on the line  $-22x + 6y = -74$ , given that  $y = \frac{11x}{3} - \frac{37}{3}$  and  $y + \frac{49}{12} = \frac{11}{3}\left(x - \frac{9}{4}\right)$  are equivalent equations.
23. Identify the slope and  $y$ -intercept, along with another point on the line  $19x + 5y = 7$ , given that  $y = -3.8x + 1.4$  and  $y + 48 = -3.8(x - 13)$  are equivalent equations.

Find the equation for each line described. Write your answer in slope-intercept form.

24. A line passes through the point  $(1, 7)$  and is parallel to a line with equation  $y = 3x + 12$ .
25. A line passes through the point  $(-3, 5)$  and is parallel to a line with equation  $y = -\frac{2}{3}x - 10$ .
26. A line passes through the point  $(0, -2)$  and is parallel to a line with equation  $y + 5 = \frac{1}{2}(x + 5)$ .
27. A line passes through the point  $(6, 0)$  and is parallel to a line with equation  $y - \frac{1}{2} = -\frac{1}{4}(x + 1)$ .
28. A line passes through the point  $(5, 3)$  and is perpendicular to a line with equation  $y = 5x + 11$ .
29. A line passes through the point  $(-4, 8)$  and is perpendicular to a line with equation  $y = -8x + 9$ .
30. A line passes through the point  $(0, 9)$  and is perpendicular to a line with equation  $y - 3 = 2\left(x + \frac{1}{2}\right)$ .
31. A line passes through the point  $(-3, 0)$  and is perpendicular to a line with equation  $y + 6 = \frac{3}{5}(x + 15)$ .

Graph each line.

32.  $y = x + 8$

33.  $-2x = y - 6$

34.  $y - 3 = \frac{1}{2}(x + 6)$

35.  $y + 2 = -\frac{1}{3}(x + 12)$

36.  $x = -5$

37.  $y = 2.5$

 APPLICATIONS

38. The following table provides the mileage and list price of pre-owned 2018 Hyundai Elantras being sold within a 50-mile radius. Round your answers to the thousandth, if necessary.

Pre-Owned 2018 Hyundai Elantra	
Mileage (miles)	Price (dollars)
14,028	19,431
26,477	18,877
16,838	19,947
32,701	18,455
29,359	20,157
17,754	19,891
31,484	18,995

- Use the car with the lowest mileage and the car with the highest mileage to create an equation to estimate the price the car should be. Let  $x$  be the mileage and  $y$  be the price.
  - Use this equation to estimate the price a dealership should use to sell a 2018 Hyundai Elantra with a mileage of 20,000 miles.
  - Explain some of the limitations of the equation created in part a.
39. The following table shows the mileage and list price of pre-owned 2018 Ford Focuses being sold within a 50-mile radius.

Pre-Owned 2018 Ford Focus	
Mileage (miles)	Price (dollars)
50,868	14,717
72,208	13,907
37,385	14,839
90,696	12,889
25,344	16,250
45,069	13,863
28,908	16,895

- Use the car with the lowest mileage and the car with the highest mileage to create an equation to estimate the price the car should be based on mileage. Let  $x$  be the mileage and  $y$  be the price.
- Use this equation to estimate the price a dealership should use to sell a 2018 Ford Focus with a mileage of 50,000 miles.
- How does the price obtained from the formula compare to the Ford Focus that has 50,868 miles? Explain why the prices might be similar or different.

40. Refer to the table from Exercise 38.
- Use the car with the lowest price and the car with the highest price to create an equation to estimate the price the car should be based on mileage. Let  $x$  be the mileage and  $y$  be the price.
  - Use this equation to estimate the price a dealership should use to sell a 2018 Hyundai Elantra with a mileage of 20,000 miles.
  - Compare the answer from part b. to the answer from Exercise 38 part b. Explain why the values are similar or different.
41. Refer to the table from Exercise 39.
- Use the car with the lowest price and the car with the highest price to create an equation to estimate the price the car should be based on mileage. Let  $x$  be the mileage and  $y$  be the price.
  - Use this equation to estimate the price a dealership should use to sell a 2018 Ford Focus with a mileage of 50,000 miles.
  - Compare the answer from part b. to the answer from Exercise 39 part b. Explain why the values are similar or different.
42. The following table shows the area of apartments along with the monthly rent.

Apartment Rent	
Area (square feet)	Price (dollars)
504	1450
723	2180
465	1040
812	1970
389	930
637	1320
558	1290

- Use the apartment with the smallest area and the apartment with the largest area to create an equation that can be used to estimate the price of rent based on the area. Let  $x$  be the area and  $y$  be the price.
- Use this equation to estimate the price a landlord should use to rent out an apartment with an area of 500 square feet. Round your answer to the nearest cent.
- How does the price obtained from the formula compare to the apartment that is 504 square feet large? Explain why the prices might be similar or different.

43. The local candy store has a bin of candies where customers can fill their own bag with whatever amount they'd like, and they are charged by depending on how much the bag weighs. The following table shows the size and price of several different bags.

Size (grams)	Price (dollars)
510	16.50
600	19.50
340	13.00
420	14.00
280	12.50
630	18.00
550	13.50

- a. Use the smallest bag and the largest bag to create an equation that can be used to estimate the price of a bag based on size. Let  $x$  be the size and  $y$  be the price.
  - b. Use this equation to estimate how much a bag filled with 500 grams of candies would cost.
  - c. How does the price obtained from the formula compare to the 510-gram bag of candies? Explain why the prices might be similar or different.
44. Refer to the table from Exercise 42.
- a. Use the apartment with the lowest price and the apartment with the highest price to create an equation that can be used to estimate the price of rent based on the area. Let  $x$  be the area and  $y$  be the price.
  - b. Use this equation to estimate the price a landlord should use to rent out an apartment with an area of 500 square feet.
  - c. Compare the answer from part b. to the answer from Exercise 42, part b. Explain why the values are similar or different.
45. Refer to the table from Exercise 43.
- a. Use the bag with the lowest price and the bag with the highest price to create an equation that can be used to estimate the price of a bag based on size. Let  $x$  be the mass and  $y$  be the price.
  - b. Use this equation to estimate how much a bag filled with 500 grams of candies would cost.
  - c. Compare the answer from part b. to the answer from Exercise 43, part b. Explain why the values are similar or different.

46. A biologist does research on two populations of bacteria, one pathogenic and the other nonpathogenic. She knows that the nonpathogenic bacteria suppress the growth of the pathogenic bacteria. The biologist estimates the population growth for the two types of bacteria with the following equations.

a. Pathogenic:  $y = 5 + \frac{t}{4}$

b. Nonpathogenic:  $y = \frac{3t}{2}$

Graph each of the lines on the same graph and use the graph to determine the number of days  $t$  required for the nonpathogenic population to suppress the pathogenic population, if this happens at all.

47. Sandy started a flower-delivery business. At first, the expenses exceeded her income, so she hired an expert to estimate when the business would start to earn profit. Based on the provided data, the expert obtained two models describing the expenses and the income of the business.

a. Expenses:  $y = \frac{3t}{2} + 1$

b. Income:  $y = 2t - 3$

Plot the two functions on the same graph. Use the graph to determine the number of months  $t$  required for the flower-delivery business to begin to earn a profit.

48. The following equations represent the amount of a product that consumers want to buy (quantity demanded) and the amount that manufacturers are ready to sell (quantity supplied) depending on the price of the product.

a. Quantity demanded:  $Q_d = 20 - 2P$

b. Quantity supplied:  $Q_s = 3P + 10$

Plot the two functions on the same graph. Use the graph to determine the equilibrium price  $P$  (given in hundreds of dollars) where supply and demand meet.

49. Suppose that the addition of some element to an alloy increases the strength and decreases the thermal conductivity of the alloy. Expressed in the same units, these properties depend on the mass of the element  $x$  (in grams per 100 g of alloy) as follows.

a. Thermal conductivity:  $y_t = 15 - \frac{x}{2}$

b. Strength:  $y_s = \frac{1}{3}(x + 5)$

Graph each of the lines on the same graph and use the graph to determine the mass of the element needed to get an alloy of optimal properties.

### ✓ Skill Check 5.3.3

Suppose you are planning to manufacture a new board game that requires an initial cost of \$5000 and an additional \$11 for each game produced. You plan to then sell each board game for \$28. Write the cost function and the revenue function for this venture. Then, find the break-even point for your board game business.

$$P(x) = 16x - 18,000$$

$$P(x) = 16(2500) - 18,000$$

$$P(x) = 22,000$$

Therefore, Harley will make a profit of \$22,000 when she sells 2500 scanners.

The break-even point might not always be an integer. Note that for many businesses, it is only possible to sell in whole units, and not in partial units. This means that if the break-even point is a fraction, you should always round up to the next whole number so that the company is actually covering *all* costs and not making a loss of even a small fraction.

### Skill Check Answers

1.  $x = -\frac{19}{2}$     2.  $(2, 4)$  is not the point of intersection    3.  $C(x) = 5,000 + 11x$ ;

$R(x) = 28x$ ; The break-even point is approximately 294.12, which rounds up to 295.

## 5.3 Exercises

### ✓ CONCEPT CHECK

- When drawing a system of linear equations, one of three things will occur:
  - The lines will \_\_\_\_\_.
  - The lines will \_\_\_\_\_.
  - The lines will \_\_\_\_\_.
- The first step in solving a system of linear equations is to \_\_\_\_\_ one of the equations for one of the \_\_\_\_\_.
- The break-even point is the amount of units that need to be produced and sold so that the \_\_\_\_\_ by the business is equal to the amount of \_\_\_\_\_.
- The \_\_\_\_\_ function is equal to the price per unit multiplied by the number of units sold.
- The \_\_\_\_\_ function is equal to the original fixed cost plus the production cost for each unit multiplied by the number of units.

### 💡 PRACTICE

Determine if the given point is the point of intersection for the pair of lines.

6.  $(3, -8)$ ;  $\begin{cases} y = -5x + 7 \\ 3x + y = 1 \end{cases}$

7.  $(6, -3)$ ;  $\begin{cases} 0.5x - 2y = 9 \\ x + 3y = 13 \end{cases}$

8.  $(-4, -5); \begin{cases} 3x + 4y = -32 \\ 2x + y = -13 \end{cases}$

9.  $\left(\frac{1}{4}, 2\right); \begin{cases} -8x = -2y \\ 6x - 3y + 6 = 0 \end{cases}$

Solve the system of equations.

10.  $\begin{cases} 4x + 3y = 1 \\ 2x - 2y = 4 \end{cases}$

11.  $\begin{cases} 2x + 4y = 8 \\ 6x - 8y = 4 \end{cases}$

12.  $\begin{cases} y = 3x - 1 \\ y = 3x + 2 \end{cases}$

13.  $\begin{cases} -\frac{2}{3}x + \frac{1}{2}y = \frac{4}{7} \\ \frac{2}{12}x - \frac{1}{8}y = -\frac{1}{7} \end{cases}$

14.  $\begin{cases} \frac{3}{4}x + 3y = \frac{4}{3} \\ -\frac{1}{4}x - y = \frac{7}{3} \end{cases}$

15.  $\begin{cases} -4x + y = 1 \\ 4x + 4y = -16 \end{cases}$

16.  $\begin{cases} 6x + y = 30 \\ 6x + y = -19 \end{cases}$

17.  $\begin{cases} x + y = -1 \\ -3x + y = -1 \end{cases}$

18.  $\begin{cases} 9x + 3y = 15 \\ 3x + y = 5 \end{cases}$

19.  $\begin{cases} y = 4x + 12 \\ 2y = 8x + 24 \end{cases}$

20.  $\begin{cases} -5x + y = -12 \\ 5y = 10x - 15 \end{cases}$

21.  $\begin{cases} 6x - y = 11 \\ -6y = -8x + 10 \end{cases}$

22. The profit function for a company selling  $x$  teapots is given by  $P(x) = 2.4x - 3230.50$ . Find the company's profit if 17,000 teapots are sold.23. If a company sells 3000 units of their product, what profit can they expect to make if their profit function is given by  $P(x) = 0.54x - 841.75$ ? APPLICATIONS24. Twelve gallons of a salt solution consists of 30% salt. This solution was created by mixing a 40% solution with a 25% solution. How many gallons of each of the solutions was used to create the 30% solution? Let  $x$  = the number of gallons of the 40% solution and  $y$  = the number of gallons of the 25% solution. The corresponding model is the following system of equations.

$$\begin{cases} x + y = 12 \\ 0.4x + 0.25y = 0.3(12) \end{cases}$$

25. A student bought a calculator and a textbook for an algebra course. He told his friend that the total cost was \$170 (without tax) and that the calculator cost \$20 more than four times the cost of the textbook. What was the cost of each item? Let  $x$  = the cost of a calculator and  $y$  = the cost of the textbook.The corresponding modeling system is  $\begin{cases} x + y = 170 \\ x = 4y + 20 \end{cases}$ . Solve the system by using the method of substitution.

26. On a round-trip to the south of the state, the pilot of a small personal plane recorded the average speed of the plane at 159 mph when flying with a tailwind. On the return trip, the plane averaged 133 mph flying back into the same wind. What was the speed of the plane in still air and the speed of the wind? Let  $x$  = the speed of the plane, and  $y$  = the speed of the wind. The corresponding model is the following system of equations. Solve the system to find the speed of the plane and the wind.

$$\begin{cases} x + y = 159 \\ x - y = 133 \end{cases}$$

27. The theater department brought in \$3072 from the sale of 723 tickets to the spring play. Unfortunately, the record of how many types of tickets were sold was lost. The department would like to know how many student tickets were bought for \$2 and how many nonstudent tickets were bought at \$5. Let  $x$  = the number of non-student tickets and  $y$  = the number of student tickets. The corresponding model is the following system of equations. Determine how many of each type of ticket was sold.

$$\begin{cases} 5x + 2y = 3072 \\ x + y = 723 \end{cases}$$

28. Ten liters of an acid solution contains 42% sulfuric acid. This mixture was obtained by combining a 30% solution with a 50% solution. How many liters of each solution was used? Let  $x$  = the number of liters of the 30% solution and  $y$  = the number of liters of the 50% solution. The corresponding model is the following system of equations. Solve the system to find the number liters used for each type of solution.

$$\begin{cases} 0.3x + 0.5y = 0.42(10) \\ x + y = 10 \end{cases}$$

29. Suppose that \$10,000 was invested in two accounts. In one year, the 7.5% mutual fund account earned \$585.45 more interest than the 3.47% CD. How much was originally invested in each account? Let  $x$  = the amount deposited in the mutual fund and  $y$  = the amount deposited in the CD. The corresponding model is the following system of equations. Determine the amount deposited in each account.

$$\begin{cases} x + y = 10,000 \\ 0.075x = 585.45 + 0.0347y \end{cases}$$

30. A farmer plans to sell harvested tomatoes at a nearby market. The cost of growing tomatoes is \$165 plus \$0.50 for each pound of the product. The farmer plans to sell the tomatoes at \$2 per pound. He wants to know how many pounds he'll need to sell in order to recoup the costs of growing tomatoes.

Write two linear functions, one for the cost of growing the tomatoes,  $C(x)$ , and one for the amount of money the farmer will earn,  $R(x)$ . Use the functions to find out how many pounds of tomatoes need to be sold in order for the farmer to not lose any money.

31. In some countries, there is a limit on water consumption per person per day. If this rate is exceeded, water supply is paid at increased rates. Suppose that a family spends 270 liters of water per day for general household needs, and each member of the family also spends 50 liters of water individually. The water consumption rate per person in this region is 140 liters per day, and this family does not exceed the allowed rate.

Write two linear functions, one for the amount of water the family spends,  $C(x)$ , and one for the amount of water specified by the consumption rate,  $R(x)$ . Use the functions to find the maximum number of people in this family given that they do not overpay for the water supply services.

32. You are investing in a new outdoor game similar to a corn-toss game, but for golf. The start-up cost includes an initial lump sum of \$9200. The production cost for each game is \$17.43 and they will be sold for \$84.99. Let  $x$  represent the number of games produced.
- Write the cost function,  $C$ .
  - Write the revenue function,  $R$ .
  - Write the profit function,  $P$ .
  - Determine the break-even point and describe what this point means.
33. A shoe company that manufactures waterproof running shoes has a fixed cost of \$100,900. Each pair of shoes sells for \$37.50 wholesale and costs \$27.60 to produce, \$1.00 to ship, \$0.30 for shipping insurance, and \$3.00 in custom taxes. Let  $x$  = the number of pairs of running shoes produced.
- Write the cost function,  $C$ .
  - Write the revenue function,  $R$ .
  - Write the profit function,  $P$ .
  - Determine the break-even point and describe what this point means.
34. A technology company is developing a new data scanner for use in hospitals. Overhead costs for manufacturing the data scanners requires a fixed cost of \$328,600. Each scanner will sell for \$10,000 and cost \$4700 to produce. Let  $x$  represent the number of scanners produced.
- Write the cost function,  $C$ .
  - Write the revenue function,  $R$ .
  - Write the profit function,  $P$ .
  - Determine the break-even point and describe what this point means.

35. A ride share company is recruiting drivers. They advertise that each driver will earn on average, \$18.26 per hour. The company charges each driver a fee of 25% of each fare. Before deciding if you want to become a driver, you calculate the hidden costs for the car you already own. Insurance, gas, maintenance, and depreciation will cost you \$8.16 per hour. Let  $x$  = the number of hours you drive for the ride share company. Answer the following questions based on the average earnings per hour as advertised by the company.
- Determine the cost function if you decide to drive for the company.
  - Determine your revenue function.
  - Determine your profit function.
  - Suppose you drive 5 hours a day for 6 days the first week and 6.5 hours a day for 4 days the second week. How much did you make your first two weeks as a driver?
  - Some drivers say that the average profit that they make per hour is actually higher than you calculated because they would be paying insurance, maintenance and have depreciation on their car anyway. Do you agree? Explain your reaction.
36. Maggie decides to become a make-up artist. To do this, she is taking a course for \$3300 and purchases the necessary materials for \$1500. She also estimates having to spend \$20 per client on supplies. Maggie expects to receive an average of \$80 per client. Let  $x$  be the number of clients.
- Write the cost function for Maggie's business.
  - Write the revenue function.
  - Write the profit function for the business.
  - Determine the  $x$ -value of the break-even point.
  - If Maggie serves 100 clients, what profit can she expect to make?
37. A company sells its product for \$40 each. Variable costs are \$12 per item, and the total fixed costs are \$56,000. Let  $x$  be the number of products sold.
- Write the cost function for the company.
  - Write the revenue function.
  - Write the profit function for the company.
  - Determine the  $x$ -value of the break-even point for the company.
  - If the company sells 3000 items, what profit can it expect to make?

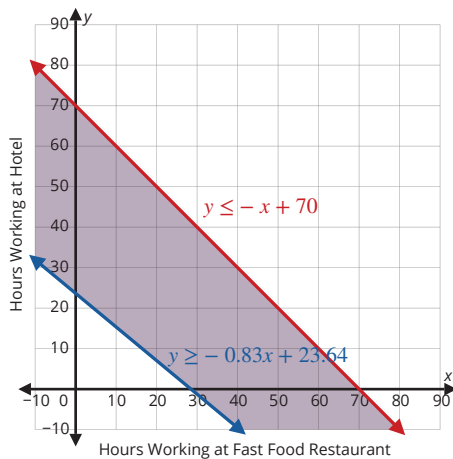

Figure 5.4.14: Solution Area

Notice that the area where the shaded regions overlap is the solution to the number of hour combinations that Elisha could work at the two jobs. We will only look at the first quadrant of the graph since, practically speaking, the number of hours that Elisha can work must be either 0 or positive.

Note that the point of intersection is included in the solution set and is graphed as a closed circle since both lines are solid. However, the point of intersection will not be shown in Figure 5.4.12, Figure 5.4.13, or Figure 5.4.14 since we are only focusing on the first quadrant.

Any point in the shaded area is a combination of hours that Elisha could work and meet his goal of earning \$260 for the week. One such combination is the point (20, 50). This means that Elisha could work 20 hours at the fast-food restaurant and 50 hours at the hotel and meet his goal. In fact, 20 hours at the restaurant earns \$182.20 and 50 hours at the hotel earns \$550. This would put Elisha well past his goal at \$732.20 for the week.

**Skill Check Answers**

- 1.
2. Closed circle at the point of intersection

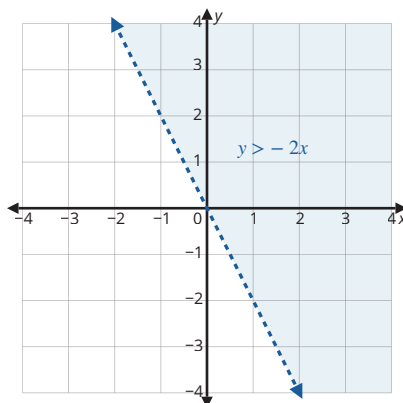

## 5.4 Exercises

✓ **CONCEPT CHECK**

1. Inequality symbols are used between two expressions that are not strictly \_\_\_\_\_.
2. When graphing the solution of an inequality equation, the \_\_\_\_\_ separates the points that satisfy the inequality from those that do not.
3. When graphing an inequality equation, a \_\_\_\_\_ can be used to determine which half-plane to shade.
4. When solving a system of linear equations, the solution region for the system is the \_\_\_\_\_ of the shaded half-planes.
5. When graphing a system of linear equations, an open circle indicates that the intersection point is \_\_\_\_\_ in the solution set.

 PRACTICE

Determine if the points given are part of the solution set for the linear inequality shown in the graph.

6. a. (1, 4)  
b. (3, 8)  
c. the origin

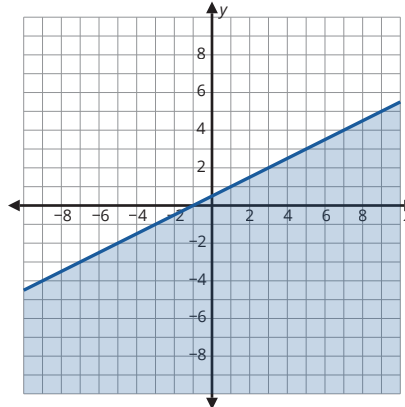

7. a. (-5, 5)  
b. (5, 6)  
c. the origin

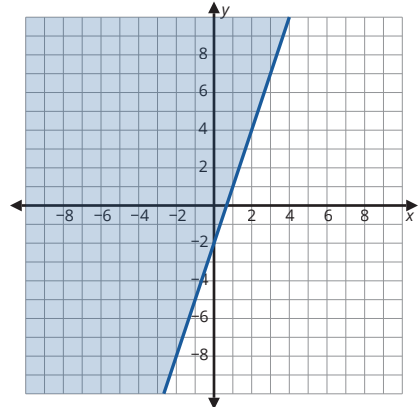

8. a. (-3, 0)  
b. (1, 8)  
c. the origin

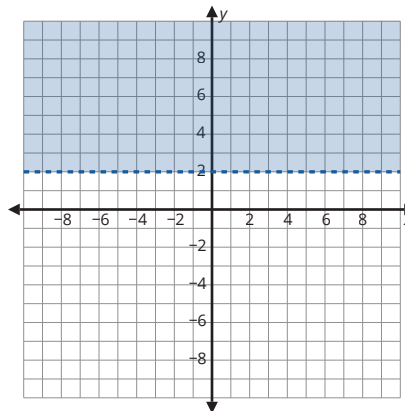

9. a. (-1, 5)  
b. (1, 0)  
c. the origin

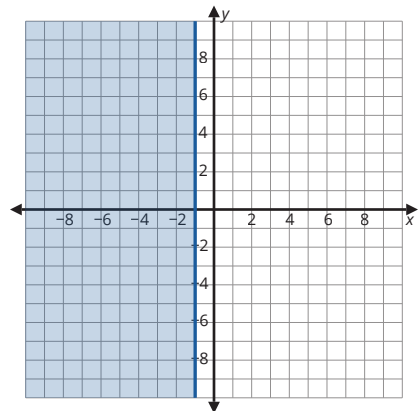

Graph the solution set for each linear inequality given.

10.  $6x + 5y < -30$

11.  $4y - 6x > 12$

12.  $-y - 2 \leq 2x$

13.  $-y + 4 \geq \frac{1}{2}x$

14.  $8y + 6x \geq 8y + 12$

15.  $y - 1 \leq 0$

16.  $6x + 8 < -6y + 8$

17.  $4 - 6y > 22 - 6x$

18.  $4x \geq -5y + 40$

19.  $-3y \leq -5x - 15$

20.  $y + 4 < -x$

21.  $\frac{4x + 5y}{20} > 1$

22.  $\frac{2x-3y}{11} \leq -1$

23.  $\frac{2}{3}x - \frac{1}{6}y > 4$

Determine if the point of intersection for the given system of linear inequalities should be an open circle or a closed circle on the graph.

24. 
$$\begin{cases} x-4y > 0 \\ \frac{1}{3}x - \frac{3}{2}y \leq -1 \end{cases}$$

25. 
$$\begin{cases} y < 5 \\ \frac{5}{6}x - 7x > 13 \end{cases}$$

26. 
$$\begin{cases} 7x+5y \leq 21 \\ x + \frac{1}{5}y \geq 2 \end{cases}$$

27. 
$$\begin{cases} x \geq -17 \\ \frac{3x+y}{2} \leq 8 \end{cases}$$

Graph the solution set to each system of linear inequalities.

28. 
$$\begin{cases} \frac{1}{4}x + y > 10 \\ 7x + y \leq -1 \end{cases}$$

29. 
$$\begin{cases} -x + 3y > 2 \\ 5x + \frac{1}{2}y > 3 \end{cases}$$

30. 
$$\begin{cases} 2x > -1 \\ y \leq 6 \end{cases}$$

31. 
$$\begin{cases} x - 0.5y \leq 1.3 \\ 3x + 8y \leq 24 \end{cases}$$

32. 
$$\begin{cases} 4x + 6y \geq 12 \\ 2.8x + 1.1y \geq 6.2 \end{cases}$$

33. 
$$\begin{cases} 7x - y \leq 14 \\ \frac{x+y}{-3} \geq -5 \end{cases}$$

### APPLICATIONS

34. Suppose you make \$2400 per month. Your obligatory payments, such as rent, your cell phone bill, etc., are \$1140 each month. You spend the rest of the money on your daily needs. Assume there are 30 days in a month.
- Model your expenses as a linear inequality. Let  $x$  be the amount you spend on average each day.
  - Can you meet your monthly budget if you spend \$45 per day?
  - Suppose the following table shows your expenses over the last six months. Graph the model of expenses created in part a along with the expenses per day on the same graph. (**Hint:** Let  $y$  represent the month.)

Expenses per Day	
Month 1	\$46
Month 2	\$42
Month 3	\$44
Month 4	\$34
Month 5	\$38
Month 6	\$39

- What daily spending amount should you aim for to meet your monthly budget? Do you think you should feel confident that you will be able to meet your budget?

35. Shelly's business sells handmade chocolate. She rents a small shop that costs her \$1200 per month, including taxes. She sells two sets of sweets, a standard set for \$14, and a premium set for \$22. The cost of making a standard set is \$6, and the cost of making a premium set is \$10.
- Model Shelly's monthly profit as a linear inequality. Let  $x$  be the number of standard sets sold and  $y$  be the number of premium sets sold.
  - Can Shelly make any profit if she sells 94 standard sets and 26 premium sets in a month?
  - Suppose the following table shows Shelly's sales over the last six months. Graph the model of monthly profit created in part a along with the sets sold day on the same graph.
  - Do you think she should feel confident that her business is profitable?

	Standard Sets Sold	Premium Sets Sold
Months 1	87	42
Months 2	94	35
Months 3	102	32
Months 4	76	44
Months 5	98	36
Months 6	83	36

36. Suppose you have a budget of \$500 for the flight and hotel for your vacation. The hotel you found is \$60 a night and your flight is \$150. Let  $x$  be the number of nights you stay.
- Write the modeling inequality for your accommodation and flight vacation budget.
  - Graph the inequality.
  - What is the maximum number of nights you can afford to stay in the accommodation?
  - How many points on the graph are solutions to the inequality and an appropriate number of nights to stay for your vacation. Explain your reasoning.
37. The city charges \$250 for a permit to use a city park for a function. To pay for the permit, a club is charging a fee of \$0.75 for each member and \$1.25 for each guest who is not a member. Let  $x$  be the number of members attending and  $y$  be the number of nonmembers attending.
- Write the modeling inequality for the number of guests needed so that the park permit is paid for.
  - Graph the inequality.
  - Would the permit be covered if only 300 members and no non-members attended?
  - how many nonmembers must attend if no members attend.
  - Identify one possible combination of member and nonmember guest counts that would cover the cost of the permit.

- 38.** Oliver supplements his income by driving for a shared-ride company and driving for a food delivery app. On average, he makes \$17.50 an hour driving for the shared-ride and \$15 an hour for the delivery app. Oliver has set a goal of making a minimum of \$50 a day by driving for these companies. Let  $x$  be the number of hours driving for the shared-ride company and  $y$  be the number of hours driving for the food delivery app.
- Write the modeling inequality for the number of hours Oliver needs to drive for each company so that he reaches his daily goal.
  - Graph the inequality.
  - If Oliver drove 2 hours for each company in one day, would he meet his goal for the day?
  - Identify one way Oliver could meet his goal of supplementing his income by at least \$50 by driving for the two companies.
  - Is the point  $(15, 10)$  a solution to the inequality? If so, is it possible for Oliver to meet his supplement goal using this solution? Explain your reasoning.
- 39.** A shipping company delivers glass vases. The company is paid \$0.80 for each safely delivered vase and is fined \$4.50 for each broken vase. The company expects to earn at least \$1500 in a delivery. Let  $x$  be the number of unbroken vases delivered and  $y$  be the number of broken vases.
- Write the modeling inequality for the shipping company's delivery earnings.
  - Graph the inequality.
  - Use the graph in part a to determine the minimum number of unbroken vases that must be delivered in order to earn \$1500.
  - Identify one possible combination of safely delivered vases and broken vases that allows the company to earn \$1500 given that at least one vase gets broken.
  - Explain why the point  $(1500, -100)$  is in the solution set for the inequality but is not a plausible solution for the shipping company.

40. Kashton is opening a fitness center for an apartment complex. As manager, he would like a full schedule of hot yoga classes as well as aerobic exercise classes. Each yoga class requires a time slot of  $1\frac{1}{2}$  hours while aerobic exercise classes require 1 hour. Kashton would like to have at least 20 hours of classes scheduled each week. Yoga instructors are paid \$35 per class and instructors for the aerobic exercise classes earn \$30 per class. Kashton has a budget of \$1000 per week to spend on instructors for the fitness classes. Let  $x$  be the number of yoga classes and  $y$  be the number of aerobic classes.
- Write two inequalities—one that represents the number of hours of classes the manager wants to have and one to represent the instructor pay required for the classes.
  - Graph the solution set for the system of inequalities.
  - Identify at least one combination of classes that meets Kashton's requirements.
  - If Kashton wants to offer the same amount of yoga and aerobic classes each week, what is the maximum number of each that he is able to offer and stay in his budget?
41. Because of her class schedule, Fern can work at most 13 hours per week. She would like to make at least \$60 a week. She makes \$15 an hour tutoring and \$8.50 an hour proofreading essays. She tutors in whole hours only but does proofreading by the half-hour. Let  $x$  be the number of hours she tutors per week and  $y$  be the number of hours she does proof reading.
- Write two inequalities—one that represents the number of hours Fern tutors and one to represent her pay.
  - Graph the solution set for the system of inequalities.
  - What is the minimum number of hours Fern can tutor without any proofreading work and make her goal?
  - What is the minimum amount of proofreading that Fern can do and make her goal if she doesn't tutor at all in the week?
  - Identify at least one combination that Fern can work and meet her goal if she does some of each type of work.
42. A nutrition plan requires that at lunch you eat a minimum of 35 gram of protein and have at most 21 grams of fat. A suggested meal includes steak and eggs. Strip steak contains 7 grams of protein and 1.9 grams of fat per ounce and eggs contain 6 grams of protein and have 4.5 grams of fat each. Let  $x$  be number of ounces of strip steak and  $y$  be number of eggs.
- Write two inequalities—one that represents the required amounts of protein and one to represent the fat.
  - Graph the solution set for the system of inequalities.
  - What is the maximum number of eggs allowed at lunch on the nutrition plan?
  - Identify an amount of steak and eggs that is allowed if the most precise you can be with measuring the steak is to the nearest half an ounce?

43. The last page in the newspaper is reserved for ads that can be purchased. There are two types of ads. The first type is a 215-character short ad, and the second type is a 380-character long ad. The page can contain at most 4000 characters. The cost of placing a short ad is \$110, and the cost of placing a long one is \$200. The newspaper wants to earn at least \$1400 on the ads. Graph the solution set to the corresponding inequality and determine the number of ads the newspaper needs to place to fit the page and earn the required amount. Find at least one combination of how many of each type of ad would meet the goal.
44. To lose weight more effectively, a trainer recommended Charlie add cardio trainings to his weight loss plan. He should burn at least 3500 additional calories per week. Charlie chose two types of cardio exercises, running and cycling. When running he will burn about 670 calories per hour, and when cycling he will burn 530 calories per hour. He also figured that he could not devote more than seven hours a week to this. Graph the solution set to determine the time Charlie needs to spend on each type of exercise to fit the trainer's expectations and the time constraints. Find at least one combination of hours Charlie should spend on each type of exercise to meet the goal.
45. A factory produces two types of glue, regular and increased adhesiveness. Only one type of glue can be produced at a time, and the factory operates 24 hours per day. The factory can produce 500 liters of regular glue or 420 liters of advanced glue in an hour, and they need to make at least 9000 liters each day. Graph the solution set to determine the time the factory should work producing each type of glue to implement the production plan. Find at least one combination of hours the factory should spend making each type of glue to meet the goal.
46. Andy is traveling to another city by bus and will not be able to charge his phone. He will have to spend at least fourteen hours on the road. To pass the time, he plans to listen to music and watch videos. The battery capacity of his phone is 2800 mAh (milliamperes/hour). Listening to music uses 43 mA per hour and watching videos uses 165 mA per hour. Graph the solution set to determine how long Andy should use his phone in each mode so that it doesn't run out of power along the way. Find at least one combination of hours spent on each activity that meets the goal.

We now substitute these points into the objective function for profit to find any maximum that may occur.

$$z = 105x + 57$$

$$(10, 15): z = 105(10) + 57(15) = 1905$$

$$(6, 23): z = 105(6) + 57(23) = 1941$$

$$(0, 27.5): z = 105(0) + 57(27.5) = 1567.5$$

$$(16, 0): z = 105(16) + 57(0) = 1680$$

$$(0, 0): z = 105(0) + 57(0) = 0$$

Therefore, the maximum of  $z = 1941$  occurs at the point  $(6, 23)$ . This means that the entrepreneur can realize their maximum profit of \$1941 when they make and sell 6 framed art pieces and 23 sets of placemats.

### Skill Check Answers

1. a. 2.  $(0, 0)$ ,  $(70, 0)$ ,  $(0, 35)$

## 5.5 Exercises

### ✓ CONCEPT CHECK

- Linear programming is a process that optimize certain quantities in a mathematical model constrained by \_\_\_\_\_.
- The \_\_\_\_\_ expresses the quantity that is to be optimized.
- Constraints express the \_\_\_\_\_ of each variable or combination of variables.
- The Fundamental Theorem of Linear Programming states that the maximal and minimal values are found at the \_\_\_\_\_ of the region.
- The \_\_\_\_\_ is the set of all points that satisfy the constraints of an optimization problem.

### 💡 PRACTICE

- Suppose you plan to build a rectangular pool on your property. You want the pool to have a volume of 350 square feet with the depth of 5 feet. To save on materials for the pool walls and pool bottom, you need to minimize the corresponding surface area. Let  $x$  represent the length of the pool and  $y$  represent the width of the pool. Write the objective function that describes the surface area of the open pool.

7. A construction company took a job for a fee of \$80,000. If the project is finished ahead of schedule, the customer will pay an additional \$2000 for each day saved. There are a limited number of employees in the company who can work on this project, so they are offered overtime. For each overtime day, the employees will receive a bonus of \$200. The company wants to maximize the profit on the project. Let  $x$  represent the number of days saved and  $y$  represent the number of days of overtime work. Write the objective function that describes the revenue for the project.
8. A florist has 200 roses a day and uses them to make two types of bouquets. The small bouquets consist of 10 roses and sell for \$35. The large bouquets consist of 25 roses and sell for \$80. The florist wants to maximize his revenue. Let  $x$  represent the number of small bouquets and  $y$  represent the number of large bouquets. Write the objective function that describes the revenue for selling the bouquets.
9. Suppose you need a task to be done as soon as possible. You can hire two types of workers, the full-time ones working 10 hours a day and the part-time ones working 6 hours a day. You have a limited budget for the task, and the full-time workers will need to be paid more per hour than the part-time ones. You want to maximize the number of working hours per day depending on the number of workers of each type. Let  $x$  represent the number of full-time workers and  $y$  represent the number of part-time workers. Write the objective function that describes the number of working hours per day.
10. Daniel has a job in cargo transportation and wants to maximize his earnings. He needs to transport several 200-pound and 600-pound loads. The carrying capacity of his truck is 45,000 pounds. He is paid \$50 for transporting a lighter load and \$100 for a heavier one. The number of lighter loads should be no more than one-third of the total number transported. Let  $x$  represent the number of lighter loads and  $y$  represent the number of heavier loads. Write the objective function that describes the amount Daniel earns for transporting the cargo.
11. A factory produces three types of cardboard boxes. The amount of cardboard needed to make each type of box is  $6 \text{ ft}^2$ ,  $4 \text{ ft}^2$ , and  $9 \text{ ft}^2$ , respectively. The first type of box sells for \$1.50, the second for \$1.25, and the third for \$2.10. You need to maximize the revenue for selling these types of boxes. Let  $a$  represent the number of boxes of the first type, let  $b$  represent the number of boxes of the second type, and let  $c$  represent the number of boxes of the third type. Write the objective function that describes the revenue.
12. Suppose you need to determine the minimum point of the objective function  $z = 380x - 415y$ . After graphing the constraints, you find the following three vertices of the feasible region polygon.
  - a.  $(100, -45)$
  - b.  $(-215, 310)$
  - c.  $(0, 70)$

Which of the points minimizes the objective function?

13. Consider the objective function  $z = -220x + 185y$ . The following three vertices of the feasible region polygon were found after graphing the constraints.

- a. (365, 450)
- b. (-160, 95)
- c. (-5, -270)

Which of the points minimizes the objective function?

14. The following three points are the vertices of the feasible region polygon for the objective function  $z = -80x - 325y$ .

- a. (130, 90)
- b. (320, 0)
- c. (-170, 120)

Which of the points minimizes the objective function?

15. Laura needs to find the maximum point of the objective function  $z = 135x + 295y$ . After graphing the constraints, she identifies the following three vertices of the feasible region polygon.

- a. (0, 400)
- b. (400, 0)
- c. (250, 250)

Which of the points maximizes the objective function?

16. Consider the objective function  $z = 340x - 230y$ . The following three vertices of the feasible region polygon were found after graphing the constraints.

- a. (60, 10)
- b. (100, 100)
- c. (0, -100)

Which of the points maximizes the objective function?

17. The following three points are the vertices of the feasible region polygon for the objective function  $z = -55x + 410y$ .

- a. (-125, 300)
- b. (0, 405)
- c. (-15, 395)

Which of the points maximizes the objective function?

18. The objective function  $z = -5x - 7y$  is subject to the following constraints.

$$y - x \geq 6$$

$$3x + 2y \leq 12$$

$$x \geq 0$$

$$y \geq 0$$

Find the maximum value of  $z$ .

19. The objective function  $z = -12x + 8y$  is subject to the following constraints.

$$x + y \leq 20$$

$$5x - y \geq 10$$

$$x \geq 0$$

$$y \geq 0$$

Find the maximum value of  $z$ .

20. The objective function  $z = 3x - 19y$  is subject to the following constraints.

$$x + y \leq 2$$

$$8y - 4x \leq 10$$

$$x \geq 0$$

$$y \geq 0$$

Find the maximum value of  $z$ .

21. The objective function  $z = 9x + 4y$  is subject to the following constraints.

$$x + y \geq 12$$

$$15y - 3x \leq 18$$

$$x \leq 24$$

$$y \geq 0$$

Find the minimum value of  $z$ .

22. The objective function  $z = -x - 6y$  is subject to the following constraints.

$$x + y \leq -15$$

$$12x - 8y \geq 20$$

$$y \geq -13$$

Find the minimum value of  $z$ .

23. The objective function  $z = 13x - y$  is subject to the following constraints.

$$2x + 5y \leq 20$$

$$-x + 5y \geq 5$$

$$x \geq 0$$

$$y \geq 0$$

Find the minimum value of  $z$ .

 APPLICATIONS

24. A plane carrying food and water to a resort island can carry a maximum of 30,000 pounds and is limited in space to carrying no more than 575 cubic feet. Each container of food weighs 175 pounds and takes up 5 cubic feet. Each container of water weighs 60 pounds and takes up 1 cubic foot of cargo space. Hotels on the island will buy the food for 14 dollars a pound and the water for 3 dollars per pound. Let  $x$  represent the number of food containers and  $y$  represent the number of water containers.
- Determine the objective function to represent the revenue generated by the plane.
  - Write the constraint inequality that describes the amount of weight the plane can carry.
  - Write the constraint inequality that describes the amount of cargo the plane can hold.
  - List any other constraints.
  - What is the optimum number of containers of each item that will maximize the revenue generated by the plane?
  - What is the maximum revenue?
25. To prevent pests, an orchard can have no more than 6 times as many apple trees as peach trees. Also, 2 times the number of apple trees plus 3 times the number of peach trees must not exceed 180. The revenue from a single apple tree is \$157 and the revenue from a single peach tree is \$423. Let  $x$  represent the number of apple trees and  $y$  represent the number of peach trees.
- Determine the objective function to represent the revenue earned.
  - Write the constraint inequality that describes that an orchard can have no more than 6 times as many apple trees as peach trees.
  - Write the constraint inequality that describes that the number of apple trees plus 3 times the number of peach trees must not exceed 190.
  - List any other constraints.
  - Determine the number of each type of tree that will maximize revenue.
  - What is the maximum revenue?

26. On your birthday, your great aunt gave you \$19,000. You would like to invest at least \$4000 of the money in municipal bonds yielding 4% and no more than \$2000 in Treasury bills yielding 6%. How much should be placed in each investment in order to maximize the interest earned in one year? Assume simple interest applies. Let  $x$  represent the amount of money in municipal bonds and  $y$  represent the amount of money in Treasury bills.
- Write the objective function to represent the interest earned in one year.
  - Write a constraint that describes the money being invested in municipal bonds.
  - Write a constraint that describes the money being invested in Treasury bills.
  - Write any additional constraints.
  - How much should be placed in each investment in order to maximize the interest earned in one year?
27. A volunteer has been asked to drop off some supplies at a facility housing victims of a hurricane evacuation. The volunteer would like to bring at least 132 bottles of water, 82 first aid kits, and 45 security blankets on his visit. The relief organization has a standing agreement with two companies that provide victim packages. Company A can provide packages of 6 water bottles, 4 first aid kits, and 3 security blankets at a cost of \$2.50. Company B can provide packages of 9 water bottles, 5 first aid kits, and 1 security blanket at a cost of \$2.00. Let  $a$  represent the number of packages provided by Company A and  $b$  represent the number of packages provided by Company B. (**Note:** The companies cannot provide partial packages.)
- Write the objective function to represent the relief organization's cost of supplies.
  - Write the constraint inequality that describes the number of bottles of water.
  - Write the constraint inequality that describes the number of first aid kits.
  - Write the constraint inequality that describes the number of security blankets.
  - List any other constraints.
  - How many of each package should the volunteer pick up to minimize the cost?
  - What amount does the relief organization pay?

28. An outdoor recreation supply company's two best-selling hammocks are made from cotton and nylon rope. The best-selling hammock requires 2.5 yards of cotton and 100 feet of rope. The second best-selling hammock needs 4 yards of cotton and 150 feet of rope. The company has 450 yards of cotton and 3000 feet of rope in stock. The best-selling hammock makes a profit of \$21 for the company and the second best-selling hammock makes a profit of \$33. Let  $x$  be the number of best-selling hammocks and  $y$  be the number of second best-selling hammocks.
- Write the objective function to represent the profit from the hammocks.
  - Write the constraint inequality that describes the number of yards of cotton.
  - Write the constraint inequality that describes the number of feet of rope.
  - List any other constraints.
  - Based on the stock the company has, how many of each hammock should the company make to maximize their profit?
29. A transport company can purchase at most 9 buses with 30 seats and at most 7 buses with 50 seats. The selling price of a 30-seat bus is \$45,000 and the selling price of a 50-seat bus is \$60,000. The company can allocate \$780,000 for the purchase of the buses. How many buses of each type should the company buy to maximize the total number of bus seats available?
30. To produce tables and cabinets, a furniture factory uses two types of wood: oak and pine. A minimum of 6 cubic feet of oak and 5 cubic feet of pine are required to produce one table. A minimum of 4 cubic feet of oak and 10 cubic feet of pine are required to produce one cabinet. Due to limited stock, the factory can use no more than 1400 ft<sup>3</sup> of oak and 2300 ft<sup>3</sup> of pine. Determine how many tables and cabinets the factory should produce to maximize the revenue if a table sells for \$1300 and a cabinet sells for \$1900.
31. For optimum prenatal care, an ob-gyn doctor recommends that expecting mothers taking a combination of supplements which included folic acid, calcium, and iron. The following table shows the recommended daily dosage for each essential nutrient along with two possible brands of multi-vitamins that contain various amounts of each. Each Baby Bliss Prenatal pill costs \$0.40 and each Natural Gift Prenatal pill costs \$0.34. How many pills of each brand should an expecting mother take each day to meet the recommended dosage and minimize the cost of supplements? Let  $x$  be the number of Baby Bliss Prenatal pills and  $y$  be the number of Natural Gift Prenatal pills.

	Recommended daily dosage	Baby Bliss Prenatal (\$0.40)	Natural Gift Prenatal (\$0.34)
<b>Folic Acid</b>	0.4 mg	0.1 mg	0.1 mg
<b>Calcium</b>	1000 mg	200 mg	400 mg
<b>Iron</b>	27 mg	9 mg	6 mg

- f. To determine how high above the fence the ball was when it went over the fence, we first need to determine the height of the ball as it went over the fence. Then, we need to subtract the height of the fence from the height of the ball.

From part e., we know that the ball went over the fence after 2.81 seconds. We can use that value for  $t$  in the height function to calculate how high the ball was when it went over the fence. Using the formula, we have the following.

$$\begin{aligned}h(t) &= -16t^2 + 87.75t + 4 \\h(2.81) &= -16(2.81)^2 + 87.75(2.81) + 4 \\h(2.81) &= 124.2399\end{aligned}$$

Thus, Acuña's homerun ball was approximately 124.24 feet off of the ground when it went over the fence.

Now we subtract the height of the fence, 8 feet 8 inches, from the ball's height. Before we can subtract, both measurements need to be in the same format.

We'll convert the fence height to a decimal form of feet:  $8 \text{ in.} \left( \frac{1 \text{ ft}}{12 \text{ in.}} \right) \approx 0.67 \text{ ft.}$

This gives that the fence is 8.67 feet tall. Now we can subtract.

$$124.24 - 8.67 = 115.57$$

Thus, the homerun ball was 115.57 feet above the fence when it went over it for a homerun.

#### ✓ Skill Check 5.6.4

Suppose a rocket is fired vertically upward from 1200 feet above the ground, with an initial velocity of 620 ft/sec. Write the quadratic model for its height  $h(t)$  in feet above the ground after  $t$  seconds and determine how long the projectile will be in flight.

#### Skill Check Answers

- $a = 3, b = -5, c = 2$  2.  $x = -\frac{3}{2}$  and  $x = \frac{9}{2}$  3.  $(3, -16)$
- $h(t) = -16t^2 + 620t + 1200$ ; approximately 40.6 seconds

## 5.6 Exercises

- A quadratic equation in  $x$  is written in standard form as \_\_\_\_\_.
- The \_\_\_\_\_ is used to determine the solutions of a quadratic equations.
- To use the quadratic formula, the quadratic equation needs to be written in \_\_\_\_\_.
- A parabola is a symmetrical U-shaped curve around a \_\_\_\_\_ line.
- The \_\_\_\_\_ of a parabola is the extreme point that represents the quadratic equations minimum or maximum.

 PRACTICE

Use the quadratic formula to solve each equation.

6.  $x^2 + 2x - 3 = 0$

7.  $x^2 - 6x - 7 = 0$

8.  $x^2 = -14x - 49$

9.  $2x^2 + 5x - 3 = 0$

10.  $2x^2 = 2x + 40$

11.  $2x^2 - 3x - 1 = 0$

12.  $3x^2 + 2x - 2 = 0$

13.  $16x^2 + 8x - 1 = 0$

14.  $(x + 5)(x - 1) = -3$

15.  $(x + 4)(x - 2) = -4$

 APPLICATIONS

16. The function  $C(x) = 0.0086x^2 + 1.11x - 1.37$  represents the stopping distance in feet while talking on a cell phone and driving at a speed of  $x$  mph. What distance will it take you to stop while talking on a cell phone if you are driving 65 mph? 75 mph?
17. The function  $W(x) = 0.02x^2 + 0.5x$  represents the stopping distance in feet on a wet road when driving at a speed of  $x$ . What distance will it take you to stop while driving on a wet road if you are driving 65 mph? 35 mph?

Use the fact that a projectile can be modeled by the function  $h(t) = -16t^2 + v_0t + y_0$  to solve the following problems.

18. A projectile is fired vertically upward from a height of 200 feet above the ground, with an initial velocity of 1100 ft/sec.
- Write a quadratic equation to model the projectile's height in feet above the ground after  $t$  seconds.
  - During what time interval will the projectile be more than 8000 feet above the ground? Round your answer to the nearest hundredth.
  - What is the total flight time of the projectile? Round your answer to the nearest hundredth.
19. A ball is thrown straight up, from ground zero, with an initial velocity of 55 feet per second. Find the maximum height attained by the ball and the time it takes for the ball to return to ground zero.
20. From the top of a 250-foot-tall building, a ball is thrown straight up with an initial velocity of 25 feet per second. Find the maximum height attained by the ball and the time it takes for the ball to hit the ground.
21. A ball is dropped from the top of a 1250-foot-tall building. How long does it take the ball to hit the ground? (Note that  $v_0 = 0$ .)
22. Grayson drops a rock into a well in which the water surface is 275 feet below ground level. How long does it take the rock to hit the water surface? (Note that  $v_0 = 0$ .)

23. A parabola-shaped floodlight is attached to the ceiling with four cables. The outermost support cables are 3 feet long and the inner cables are 1.5 feet long. The shape of the floodlight can be modeled by the quadratic equation

$$y = -\frac{x^2}{8} - 1, \text{ where } x \text{ is the horizontal distance from the center of the floodlight and } y \text{ is the vertical distance from the ceiling to the floodlight. Let the center of the floodlight be placed at } 0 \text{ on the } x\text{-axis. What does the distance between the inner cables and the outer cables need to be? A simplified rendering of the floodlight is shown in the following figure.}$$

Let the center of the floodlight be placed at 0 on the  $x$ -axis. What does the distance between the inner cables and the outer cables need to be? A simplified rendering of the floodlight is shown in the following figure.

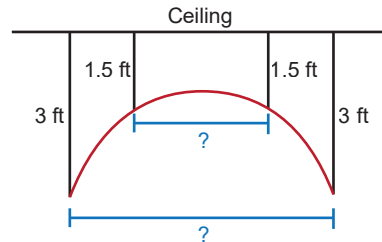

24. A domed roof is mounted on two types of columns. The outermost support columns are 15 feet high, and the interior decorative columns are 18 feet high. A simplified rendering of the construction is shown in the following figure. The shape of the roof can be modeled by the quadratic equation

$$y = -\frac{(x-10)^2}{25} + 19, \text{ where } x \text{ is the horizontal distance from the leftmost column and } y \text{ is the vertical height from the floor to the roof. Let the leftmost column base be placed at the origin. What is the distance between the two inner columns? What is the distance between the two outer columns?}$$

Let the leftmost column base be placed at the origin. What is the distance between the two inner columns? What is the distance between the two outer columns?

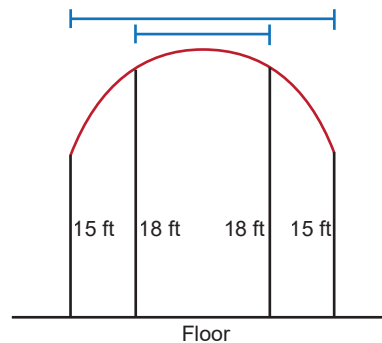

25. The shape of the bottom of a pool can be modeled by the quadratic equation
- $$y = \frac{(x-4)^2}{8} - 2, \text{ where } x \text{ is the horizontal distance from the leftmost pool edge and } y \text{ is the depth of the pool. Let the leftmost pool edge be placed at the origin. What is the distance from the edge to the place where the depth is 1.5 meters? What is the length of the pool? A simplified rendering of the pool is shown in the following figure.}$$

Let the leftmost pool edge be placed at the origin. What is the distance from the edge to the place where the depth is 1.5 meters? What is the length of the pool? A simplified rendering of the pool is shown in the following figure.

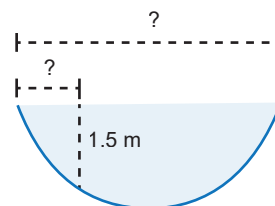

26. Due to their reflectivity, parabolas are used in the construction of amphitheaters so that the audience can clearly hear the actors. Suppose the amphitheater is built based on the parabola where  $x$  is the horizontal distance from the center of the amphitheater and  $y$  is the vertical height from the scene to the seats on the specific row. Let the center of the theater be placed at 0 on the  $x$ -axis. What is the distance between the center and the seats at the 2.5-meter height? What is the distance between the center and the seats at the 10-meter height? A simplified rendering of the amphitheater is shown in the following figure.

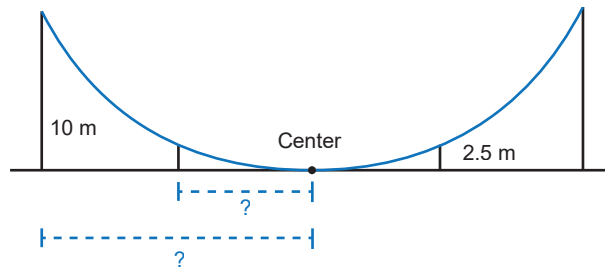

27. After a golfer hits a ball that is lying on the ground, it flies along the trajectory given by the quadratic equation  $y = -\frac{x^2}{4} + \frac{3x}{2} + \frac{7}{4}$ , where  $y$  is the height of the ball above the ground and  $x$  is the horizontal coordinate of the ball, both in meters. Assume the land from the initial location of the ball to the hole is flat.
- Determine how far the hole must be from the golfer for the ball to land in it.
  - What is the maximum height the ball will reach?
28. A suspension bridge has the shape of a parabola that can be described by the quadratic equation  $y = \frac{1}{20}(x^2 - 4x - 21)$ , where  $x$  and  $y$  are the horizontal and vertical coordinates of the points on the bridge, both in meters, and the bridge connects to its supports at the level of  $y = 0$ .
- Determine the distance between the bridge supports.
  - What is the maximum “depth” of the bridge?
29. The cross section of a glass is a parabola described by the quadratic equation  $y = x^2 + x - \frac{35}{4}$ , where  $x$  and  $y$  are the horizontal and vertical coordinates of the points on the glass, both in centimeters, and the edge of the glass is on the level of  $y = 0$ .
- Determine the diameter of the glass.
  - What is the maximum depth of the glass?

30. An arch in the form of a parabola is installed at the entrance to the city. It can be described by the quadratic equation  $y = -\frac{x^2}{4} + \frac{7x}{2}$ , where  $y$  is the height of the arch and  $x$  is the horizontal distance from one of the arch bases, both in meters.

- a. Determine the distance between the arch bases.
- b. What is the maximum height of the arch?

31. The flight paths of a ball thrown from a hill under various conditions are modeled with the following quadratic functions, where  $x$  is the time in seconds, and the value of the function is the height, in meters, of the ball above the base of the hill.

Height under Normal Conditions:  $f(x) = -\frac{x^2}{40} - \frac{x}{10} + 8$

Height When It's Windy:  $g(x) = -\frac{2x^2}{49} + 8$

Height When It's Rainy:  $h(x) = -\frac{x^2}{20} - \frac{x}{15} + 8$

Each of the curves are depicted in the following figure.

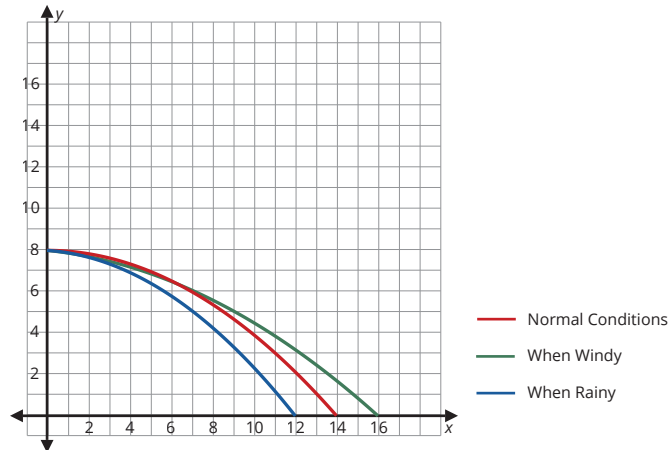

- a. Determine the height of the ball for each condition after 10 seconds.
- b. If a person who is 1.7 meters tall stands at the base of the hill, how far above the person will the ball be after 10 seconds?
- c. If a person can catch the ball when it is 1.7 meters above the ground, how long will the ball fly before being caught under normal conditions and when it's rainy.
- d. Use the graphs in the figure to compare the heights of the ball for each of the weather conditions.

32. A biologist studied the growth rate of geraniums under various conditions for 60 days. His results are modeled with the following quadratic functions, where  $x$  is the time in days, and the value of the function is the height of the plant, in centimeters, corresponding to that time.

No Specific Conditions:  $f(x) = 0.006x^2 + 0.021x + 12$

With an Additional Light Source:  $g(x) = 0.01x^2 + 0.013x + 12$

With Fertilizers:  $h(x) = 0.009x^2 - 0.03x + 12$

Each of the curves are depicted in the following figure.

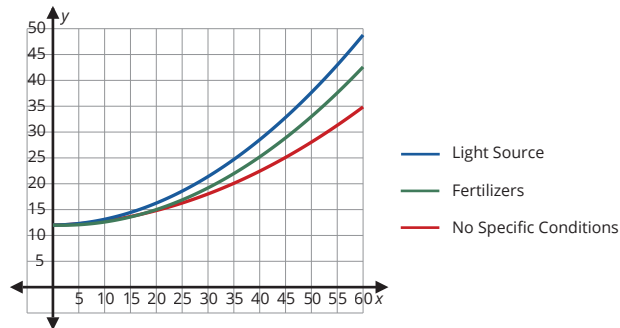

- Determine the height of the plant for each condition after 30 days.
  - At the beginning of the experiment, all three plants had the same height, 12 centimeters. By how many times did the plants grow from their original size in 30 days?
  - Find the time required for the plant to grow twice its original size when there is an additional light source and when there are fertilizers.
  - Use the graphs in the figure to compare the heights of the plant for each growth condition.
33. You may have noticed that sometimes the water in ponds or aquariums can turn blue-green. This is due to the increased reproduction of cyanobacteria. The reproduction rate of cyanobacteria is described by an equation of the form  $N(t) = N_0 e^{rt}$ , where  $N_0$  is the initial population size (given in millions of cells per liter),  $r$  is the growth rate, and  $t$  is the time in hours.
- Among other factors, the growth rate is dependent on the concentration of phosphates in the water. This dependency is modeled by the linear function  $r = 2p$ , where  $p$  is the concentration of phosphates given in milligrams per liter.
- Write the exponential function of the population size  $N(t)$  if the concentration of phosphates is normal; that is, equals 1 mg/L.
  - Write the exponential function of the population size  $N(t)$  if the concentration of phosphates is twice the norm and the initial population size is  $3.3 \times 10^6$  cells/L.
  - Use the function from part b. to calculate the population size after 2 hours.
  - Use the function from part a. to calculate the time required for the population to double.

34. When you put your money into a savings account, its future value depends, among other things, on the way the interest is calculated. Let's consider two options.

Simple Interest: The future value of an account with a simple interest is calculated by the formula  $A = P(1 + rt)$ , where  $P$  is the initial deposit,  $r$  is the annual percentage rate (APR) written as a decimal, and  $t$  is the length of the deposit in years.

Continuous Compound Interest: The future value of an account with a continuous compound interest is calculated by  $A = Pe^{rt}$ , with the variables having the same meanings.

- Write the linear function for the future value of an account using the simple interest rate if the initial deposit is \$10,000 and the APR is 2.43%.
  - Use the same values for the initial deposit and the APR to write the exponential function for the future value of an account using the continuous compound interest.
  - Compare the future values of the accounts after 5 years using the functions found in parts a. and b.
  - How long does it take for the accounts to earn the first \$1000 of interest? Use the functions obtained in parts a. and b. to determine how long it takes the accounts to earn the first \$1000 of interest.
35. Consider a diver jumping from a platform into the pool. His height above the water can be modeled by the quadratic equation  $h(t) = -5t^2 + v_0t + y_0$ , where  $t$  is the number of seconds after the jump,  $v_0$  is the initial vertical velocity of the diver, and  $y_0$  is the height of the platform in meters. At the same time, the horizontal distance from the diver to the platform is described by the function  $d(t) = v_1t$ , where  $v_1$  is the initial horizontal velocity.

Assume that the height of the platform is 6 meters, the initial vertical velocity is 3.9 m/s, and the initial horizontal velocity is 2.32 m/s. Answer the following questions.

- Write the quadratic function for the height of the diver above the water after  $t$  seconds.
- Write the linear function for the horizontal distance the diver will travel after  $t$  seconds.
- How high above the water will the diver be after 0.8 seconds?
- How long will it take for the diver to hit the water?
- What is the maximum height above the water the diver can reach?
- At what time  $t$  will the height in part e. be reached?

36. Suppose the revenue of a company is described by the linear function  $R(p, Q) = pQ$ , where  $p$  is the price of an item produced and  $Q$  is the number of items sold. The quantity  $Q$  is linearly dependent on the price and can be modeled by  $Q(p) = -2000p + 134,000$ . Suppose 15,000 items were sold last month. Answer the following questions.
- Write the linear function for last month's revenue using the given number of items sold.
  - Write the quadratic function for the revenue, assuming that the quantity is a function of price.
  - What is the revenue if the price of the item is \$23? Use the function obtained in part b.
  - What is the maximum revenue the company can achieve based on the function obtained in part b?
  - What price corresponds to the maximum revenue found in part d?

## 5.6 PROJECT

### THE WEIGHTLESSNESS OF PARABOLIC ARCS

A reduced-gravity aircraft is an aircraft that can simulate weightlessness of its passengers and contents by following a parabolic flight path. While zero gravity (zero-g) is not perfectly attained, the simulation is close enough to zero-g to train astronauts and film movie scenes. This type of aircraft has lovingly been given the nickname “vomit comet” due to two-thirds of all passengers experiencing airsickness during the 40 to 60 parabolic maneuvers of the flight.

According to NASA, the function  $f(t) = -4.9t^2 + 87.21t + 9144$  can be used to describe the altitude in meters of a certain reduced-gravity aircraft  $t$  seconds after the start of the parabolic maneuver. Reduced gravity occurs during the entire parabolic arc of the maneuver.

- Determine the altitude when reduced gravity starts and ends.
- How long does the reduced-gravity period last? Round your answer to the nearest tenth of a second.
- What is the maximum height attained by the aircraft during the parabolic maneuver? At what time into the parabolic maneuver is this height attained? Round your answer to the nearest tenth.

Suppose an 80-second movie scene takes place in zero-g. The production crew needs to plan the film sequence to minimize the cost of renting a reduced-gravity aircraft.

- The 80-second scene would need to be split up across multiple periods of weightlessness and then stitched together in editing. What is the minimum number of parabolic arcs the movie crew would need to film the entire scene once?
- If it takes the aircraft approximately 5 minutes from the end of one parabolic arc to set up to start another parabolic arc, how long would it take to film the 80-second scene one time?

**Skill Check Answers**

- a. 8:27 a.m. b.  $\frac{1}{16}$  full
- One half step up is F# and one half step down is E.
- $f(23) \approx 2.262$
- About 63 times stronger.

## 5.7 Exercises

**✓ CONCEPT CHECK**

- An exponential function has the form \_\_\_\_\_.
- The expanded form of an exponential function has the form \_\_\_\_\_.
- \_\_\_\_\_ is the sound of a number of energy wave cycles completed in one second.
- A logarithm has the form \_\_\_\_\_.
- A logarithm has a base of \_\_\_ is referred to as a common logarithm.

**🔑 APPLICATIONS**

- Bacteria in a bottle are quadrupling every minute. If the number of bacteria in the bottle at noon is 1, how many bacteria are in the bottle at 12:10 p.m.?
- The population of Greene Hills is decreasing at a rate of 2% per year. If the population is 20,000 today, what will the population be in 10 years?
- The price of a gallon of milk is increasing at a rate of 1% per year. If a gallon of milk costs \$3.50 in 2014, how much will a gallon of milk cost in 2017?
- The current population of a town in California is modeled by the function where  $x$  is the number of years since January 1, 2022 .
  - What was the initial population on January 1, 2022?
  - What will the population be on January 1, 2025?
  - What will the population be on January 1, 2030?

10. A checkerboard has 64 squares that alternate black and white. A grain of rice weighs 0.03 grams. Assume 1 grain of rice is placed on the first square, 2 grains are placed on the second square, 4 grains are placed on the third square, and so on.

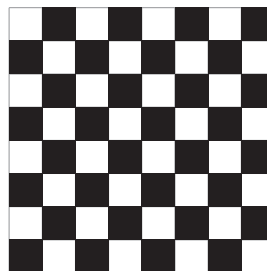

- How many grains will be placed on the 14th square?
- How many grains will be placed on the 25th square?
- How much does the rice on the 20th square weigh?
- How much does the rice on the 30th square weigh?

Use the given information and logarithmic equation to answer each question.

$\text{pH} = -\log[\text{H}^+]$  where  $[\text{H}^+]$  is the hydrogen ion concentration, measured in moles per liter. Solutions with a pH-value of less than 7 are acidic; solutions with a pH-value of greater than 7 are basic; solutions with a pH-value of 7 (such as pure water) are neutral.

- Suppose that you test apple juice and find that the hydrogen ion concentration is  $[\text{H}^+] = 0.0003$ . Find the pH value and determine whether the juice is basic or acidic. Round your answer to the nearest hundredth.
- You test some ammonia and determine the hydrogen ion concentration to be  $[\text{H}^+] = 1.3 \times 10^{-9}$ . Find the pH value and determine whether the ammonia is basic or acidic. Round your answer to the nearest hundredth.
- An orange has a pH of about 3. Find the concentration of hydrogen ions in an orange.
- An antacid tablet has a pH of 11. Find the concentration of hydrogen ions in the tablet.
- Acid rain has a pH of 4 and normal rain has a pH of 6. Compare the pH of each and determine how much more acidic acid rain is than normal rain.

Solve each problem. Round your answer to the nearest thousandth, if necessary. Assume middle C has a frequency of 261 Hz.

- If a note has a frequency of 27.5 Hz, find the frequencies of the notes one, two, three, four, and five octaves higher.
- If a note has a frequency of 220 Hz, find the frequencies of the notes one, two, and three octaves higher.

18. If a note has a frequency of 4176 Hz, how many octaves higher is the note than middle C?
19. If a note has a frequency of 1044 Hz, how many octaves higher is the note than middle C?
20. What is the frequency of the note that is nine half steps below middle C?
21. What is the frequency of the note that is nine half steps above middle C?
22. Two podcasts, one on psychology and one on medicine, were both launched about a year ago. By now, the psychological podcast has 23,000 subscribers, and the medical one has 34,000 subscribers. Both podcasts estimate their future growth. The psychology podcast projects an increase of 45% in the number of subscribers each year, while the medical podcast plans to increase its coverage by 28,000 subscribers per year.
  - a. Create a function model for the projected growth over time for both podcasts.
  - b. How many subscribers is each podcast predicted to have in 5 years?
  - c. Approximately how many years would it take for the two podcasts to have the same number of subscribers?
  - d. How many years would it take the psychology podcast to reach 1 million of subscribers?
23. Suppose you want to borrow \$50 from either your brother or your sister for a week. They each offer you a different condition for borrowing money. Your brother asks for an additional \$5 for each day that you are late paying back the money. Your sister says she will increase the total amount you owe her by 10% per day for each day you are late returning the money. Your brother and sister both want the full amount paid back all at once.
  - a. Create function models for the money you need to return to both siblings based on the number of days you are late paying back the money.
  - b. How much money do you need to return in both cases if are 3 days late in paying back the money?
  - c. Assuming you are unable to pay the money back on time, after how many days would you owe equal amounts to your siblings?
  - d. If you knew that you would be at least 2 days late paying back the money, who would you borrow money from?

Use the given information and logarithmic equation to answer each question. Round your answer to the nearest whole number, if necessary.

Sound intensity, given in decibels, is measured by the formula

$$db = 10 \log \left( \frac{I}{I_0} \right). \quad I \text{ is the intensity of the sound in question relative to the reference value } I_0 \text{ which has the value } I_0 = 1.$$

24. A dog bark is 400 times as intense as the reference value  $I_0$ . How many decibels is a dog bark? Round your answer to the nearest whole decibel.
25. A jet engine is about 155 decibels. What is the intensity level of the jet engine? Round your answer to the nearest whole number.
26. The threshold of hearing loss is about 125 decibels. If a gunshot has an intensity of  $5.012 \times 10^{12}$ , should you wear ear protection to prevent hearing loss?

Use the given information and logarithmic equation to answer each question. Round your answer to the nearest hundredth, if necessary.

The magnitude of an earthquake on the Richter scale is measured by

$$R = \log \left( \frac{I}{I_0} \right)$$

27. What is the magnitude of an earthquake that is  $5 \times 10^8$  times as intense as a zero-level quake?
28. A dump truck has an intensity of about 975. If a seismograph will register a quake of anything larger than a magnitude of 3, will the dump truck cause a small earthquake on the seismograph?

### WRITING & THINKING

29. In a given 30-day month, would you rather get a penny on day 1, two pennies on day 2, and continue to double that amount each day from the previous day, or start with a quarter on day 1, 2 quarters on day 4, 4 quarters on day 7 and continue to double the amount from the previous amount every 3rd day? Explain your reasoning.

## 5.7 PROJECT

### USING NEWTON'S LAW OF COOLING TO AVOID COFFEE BURNS

Newton's Law of Cooling gives the temperature of an object (such as a pan or a cup of liquid) as it cools over time to the temperature of its surrounding environment (such as the air in a room). The law can be described with the following function.

$$T(t) = T_e + (T_0 - T_e)e^{-kt}$$

B2		fx				
		=(1+A2/365)^365-1				
	A	B	C	D	E	F
1	APR	APY				
2	9.95%	0.104603				
3	6.49%	0.067046				
4	5.95%	0.061301				

FIGURE 6.1.11

Converting these APYs to percentages and rounding to the nearest hundredth we have 10.46%, 6.70%, and 6.13%.

Now, we are ready to complete the table. Notice that the difference between the APY and the corresponding APR is not the same for all levels, even though the compounding periods are the same.

Table 6.1.7: APD Bank of the South Personal Loan Rates

Loan Amount	APR*	APY
< \$20,000	9.95%	10.46%
\$20,000 – \$99,999	6.49%	6.70%
≥ \$100,000	5.95%	6.13%

\*Interest is compounded daily, and accrued interest is posted to the account monthly.

### Skill Check Answers

1. \$5292 2. \$14,802.78 3. \$1454.99 4. 4.28%

## 6.1 Exercises

### ✓ CONCEPT CHECK

- The amount of money that you are charged for \_\_\_\_\_ money is called interest.
- The two types of interest are \_\_\_\_\_ interest and \_\_\_\_\_ interest.
- With compound interest, the interest charged applies not only to the \_\_\_\_\_, but also to any interest that has already been accrued.
- The largest amount of interest that could possibly accrue over a given time period is \_\_\_\_\_.
- True or False: Simple interest grows exponentially.

 PRACTICE

Calculate the simple interest for each situation. Round your answer to the nearest cent, if necessary.

6. Determine the interest owed on \$800 for 5 years at a rate of 8.5%.
7. Determine the interest owed on \$5000 for 2 years at a rate of 10%.
8. Determine the interest owed on \$1200 for 30 months at a rate of 19.5%.
9. Determine the interest owed on \$550 for 5 years at a rate of 8.5%.
10. Determine the simple interest owed on \$2700 for 3 years at a rate of 15%.
11. Determine the simple interest owed on \$1050 for 18 months at a rate of 8%.
12. Determine the future value owed on \$1300 after 5 years at a simple interest rate of 3.2%.
13. Determine the future value owed on \$3200 after 4 years at a simple interest rate of 4%.

Use the compound interest formula to find the following for each situation.

- a. Calculate the total amount in the account after the given time period.
  - b. Determine the amount of interest earned for each.
14.  $P = \$2500$ ,  $r = 6.5\%$  compounded weekly,  $t = 10$  years
  15.  $P = \$3500$ ,  $r = 4.5\%$  compounded monthly,  $t = 10$  years
  16.  $P = \$2500$ ,  $r = 6.5\%$  compounded daily,  $t = 10$  years
  17.  $P = \$5650$ ,  $r = 8\%$  compounded biannually,  $t = 15$  years
  18.  $P = \$2500$ ,  $r = 6.5\%$  compounded yearly,  $t = 10$  years
  19.  $P = \$15,000$ ,  $r = 6\%$  compounded semiannually,  $t = 25$  years
  20.  $P = \$12,500$ ,  $r = 8\%$  compounded biweekly,  $t = 15$  years
  21.  $P = \$7300$ ,  $r = 19.9\%$  compounded weekly,  $t = 20$  years

22. Angela deposits \$2500 into an account with an APR of 5.5% for 10 years. Find each of the following.
- Amount of interest earned if the account is compounded annually
  - Amount of interest earned if the account is compounded monthly
  - Amount of interest earned if the account is compounded weekly
  - Amount of interest earned if the account is compounded daily
  - Amount of interest earned if the account is compounded continuously
23. David deposits \$4000. Determine the APY for each of the following.
- APR of 5% compounded monthly
  - APR of 5% compounded weekly
  - APR of 5% compounded daily
  - APR of 7.5% compounded monthly
  - APR of 7.5% compounded weekly
  - APR of 7.5% compounded daily
24. Determine the simple interest earned on \$10,000 after 10 years if the APR is each of the following rates.
- 3%
  - 6%
  - 12%
  - 24%

### APPLICATIONS

25. Julia takes out a simple-interest loan to buy a new TV set. If she borrows \$1500 for 2 years at a rate of 12%, how much interest will she have to pay back?
26. Suppose a friend asked you to lend him \$3500 and promised to return the money several years later with a 10% annual interest. How much interest will he pay you if he decides to return all the money in two and a half years?
27. Suppose your bank gives you a special offer for a simple interest loan of \$10,000 for 5 years at an annual interest rate of 5%. How much will you owe the bank at the end of the loan term?
28. Kamil deposits \$3000 in an account with a simple interest rate of 2.2%. If he decides to take all the money from the account after 8 years, how much will he withdraw?

29. A lending company offers small personal loans with a simple interest rate. If the loan is paid off in full within 30 days, the annual interest rate is 14%. If you take more than 30 days to return the full loan amount, the interest is calculated at an annual rate of 31% on the original loan amount. How much would you need to pay back to the company if you borrowed \$400 and returned the full loan amount after 15 days?
30. Lina is purchasing a new washing machine on credit at a simple annual interest rate of 24.99%. How much will she owe the store in 60 days if the price of the washer is \$650?
31. Emiel deposits \$700 on a savings account with a simple annual interest rate of 6.5%. What will the future value of his account be after 180 days?
32. Bart deposits \$6000 into an account with an annual percentage rate of 3.1% compounded daily. What will the future value of his account be after 5 years?
33. A bank offers Eleanor a loan of \$9000 for 8 years with an annual interest rate of 5.5% compounded monthly. What will the future value of the loan be at the end of the loan period?
34. Barbara added \$2100 to her bank account that already had \$6200. How much will she have in the account after 2 years if the interest is compounded quarterly at an annual rate of 2.4%?
35. To buy a car, Cornelis takes out a loan of \$13,500 for 15 years with an annual interest rate of 1.35% compounded semiannually. What is the total cost of the car, including interest?
36. Laura needs \$3600 to renovate her condo and plans to take out a two-year loan for this purpose. After searching through available bank offers, she narrowed the choice to two banks. The first bank offered an APR of 4.4% compounded semi-annually, and the second bank offered an APR of 3.9% compounded monthly. Which of the offers should Laura choose?
37. Ralph ponders which of two banks he should place his money in. The first bank offers an APR of 2.15% compounded monthly. The second offers an APR of 2.29% compounded quarterly. Ralph has \$12,000 and plans to leave it in the bank for at least 7 years. Which of the banks should he choose?
38. Donald invests \$7000 into an account that pays 2.3% interest compounded continuously.
- Find the future value of his account in 6 years.
  - How long will it take for his account to be worth \$10,000?
39. In order to get an implant in place of her extracted tooth, Rachel takes out a five-year loan for \$4000 with a 5.58% interest rate compounded continuously.
- How much will she need to repay at the end of the loan term?
  - If she wants her total repayment to be no more than \$5000, for how long can she borrow the money?

40. If you deposit \$4500 into an account with an interest rate of 2.19% compounded continuously, how much will you have in the account in 10 years?
41. Suppose that in 2020 Amanda deposited \$14,000 into an account that earns 1.89% APR and is compounded continuously. What will be the value of her investment in 2030?
42. After getting a part-time job, Evelyn decided to move from the student dorm to her own apartment. She borrowed \$1600 to pay the deposits to rent the apartment and decided to pay it back over the course of two years. How much will she need to pay in total if the interest rate is 4.4% compounded continuously?
43. Samuel buys a new refrigerator using an in-store offer for a loan with an APR of 22.5% compounded continuously. If the refrigerator costs \$1250, how much will Samuel owe the store after half a year?
44. After selling an old car she got from her parents for \$11,000, Leah decided to place the money in a savings account with an APR of 3.07% compounded continuously. How long will it take for the money in the account to increase by \$1000?
45. How long would it take for \$26,000 invested at a rate of 4.09% compounded continuously to reach the value of \$30,000?
46. Joshua takes a loan of \$2000 with an APR of 8.01% compounded continuously. How long will it take for the amount owed to increase by \$700?
47. How long would it take for an amount owed to double if the interest rate is 10.39% compounded continuously?
48. A bank is offering new customers an IRA that earns 1.75% APR compounded monthly. Adam uses this offer to deposit \$15,000 for 10 years. What is the annual percentage yield for this deposit?
49. Peter invests \$34,000 for six years into an account with an APR of 2.12% compounded daily. Find the annual percentage yield for this investment.
50. If \$9000 is invested for 4 years at an interest rate of 7.19% compounded semi-annually, what will be the annual percentage yield?
51. Megan places \$6000 into a savings account for one year. The APR for this account is 1.65% and is compounded quarterly. What is the annual percentage yield for her deposit?
52. Assume you wish to borrow \$500 for two weeks and the amount of interest you must pay is \$20 per \$100 borrowed. What is the APR at which you are borrowing money? Round your answer to the nearest hundredth.
53. Suppose your salary in 2022 is \$65,000. If the annual inflation rate is 4%, what salary do you need to make in 2030 in order for it to keep up with inflation?

54. Suppose the First Bank of Lending offers a CD (Certificate of Deposit) that has a 6.45% interest rate and is compounded quarterly for three years. You decide to invest \$5500 into this CD.
- Determine how much money you will have at the end of the three years?
  - Find the APY.
55. The First Bank of Lending lists the following APR for loans. Determine the APY, or effective interest rate for each category.

First Bank of Lending Loan APR	
Loan Amount	APR
< \$20,000	11.25%
\$20,000–\$99,999	8.99%
≥ \$100,000	5.75%

\*Interest rates are compounded quarterly

### WRITING & THINKING

56. You are purchasing a new computer using the store’s “90 days same as cash” deal. If the cost of the computer is \$1575 (tax included) with an annual interest rate of 19.99%, how much would you owe on the 91st day if you make no payments during the first 90 days?

## 6.1 PROJECT

### INFLATION AND TIME TRAVEL: THE VALUE OF MONEY OVER TIME

In 1979, the federal minimum wage in the United States was \$2.90 per hour. By 2019, that number increased to \$7.25 per hour. While there is a clear increase in the minimum wage in dollars, it is hard to compare the two figures without knowing more about how the economy changed between 1979 and 2019.

In this activity, you will explore different ways to compare the value of money across different time periods.

Economists define inflation as the rise of price levels in the economy over time. The average yearly rate of inflation between 1979 and 2019 was 3.2%. That means prices of goods and services went up by an average of 3.2% every year between 1979 and 2019.

- Suppose that an item cost \$1.00 in 1979. What was the price of that item in 2019 when adjusted for inflation? (**Hint:** You can think about this in terms of an investment that compounds interest—if you invested \$1.00 in 1979 at 3.2% compound annually, how much would you have in 2019?)

The answer to part 1 represents the value of \$1.00 of 1979 currency in 2019 when adjusted by inflation.

## 6.2 Exercises

### ✓ CONCEPT CHECK

1. The \_\_\_\_\_ is the amount you need to invest now in order to meet a future goal.
2. A sequence of \_\_\_\_\_ made into or taken out of an account is called an annuity.
3. If you buy stock in a company, you are buying a share in the ownership of that company, and you become a \_\_\_\_\_.
4. A dividend is the money that is divided amongst shareholders when a \_\_\_\_\_ earns a profit.
5. True or False: Contributions to a Roth IRA are taxed before they are deposited, but withdrawals are not taxed.

### 💡 PRACTICE

For each situation, use the formula for present value of money to calculate the amount you need to invest now in one lump sum. Round your answer to the nearest cent, if necessary.

6. \$25,000 after 10 years with an APR of 8% compounded monthly
7. \$25,000 after 10 years with an APR of 12% compounded monthly
8. \$100,000 after 18 years with an APR of 6% compounded quarterly
9. \$1,000,000 after 40 years with an APR of 10% compounded monthly
10. \$22,000 after 12 years with an APR of 7% compounded quarterly
11. \$54,000 after 8 years with an APR of 9% compounded semiannually
12. \$115,000 after 15 years with an APR of 11% compounded monthly
13. \$800,000 after 30 years with an APR of 13% compounded quarterly

A CD, or “certificate of deposit,” is a type of savings account with a fixed rate and term, meaning you can only redeem it when the term is over. Answer the following questions about CDs. Round your answers to the nearest cent, if necessary.

14. What is the profit earned on a 6-month CD with a face value of \$600 and a 0.45% APR compounded monthly?
15. What is the profit earned on a 1-year CD with a face value of \$2000 and a 0.51% APR compounded monthly?

16. What is the profit earned on a 3-year CD with a face value of \$1500 and a 0.71% APR compounded monthly?
17. What is the profit earned on a 5-year CD with a face value of \$800 and a 0.77% APR compounded monthly?

### APPLICATIONS

18. Revere College predicts that in 18 years it will take \$200,000 to attend the college for four years. Debbie wishes to save money for her child's college fund. How much should Debbie put aside in an account with an APR of 9% compounded monthly in order to have \$200,000 in the account in 18 years?
19. Richard just entered a university, and his parents are planning to give him a car upon graduation. How much should they invest into an account with an APR of 10% compounded monthly if they estimate that in four years the car will cost \$15,000? Round your answer to the nearest cent.
20. Bella plans to buy a new laptop that should be released in a year. She predicts that the laptop will cost about \$2500. How much should she deposit now into an account with an APR of 5% compounded monthly so that the account accrues enough money to cover the cost of the laptop when it is released? Round your answer to the nearest cent.
21. Anita sets a goal to have \$100,000 in her account when she turns 40. What amount of money should she invest now at an APR of 4% compounded monthly to reach her goal if she is 22 this year? Round your answer to the nearest cent.
22. Raul's vision started to deteriorate while he was in middle school, and by the time he entered high school, he had to wear glasses. Together with his parents, he plans to undergo a laser vision correction in 6 years when he turns 21. They estimate the cost of the surgery at that time will be \$5500. How much should they deposit into an account with an APR of 8% compounded quarterly to obtain the desired sum in 6 years? Round your answer to the nearest cent.
23. Kevin learns that the game he has long awaited will be released in two years. He is not sure that his computer will be able to handle this game, so he decides to buy a new one. He estimates that the cost of the computer will be \$3200. If he wants to have enough money to buy it by the time the game is released, how much should he invest into an account with an APR of 4.5% compounded monthly? Round your answer to the nearest cent.
24. Carol wants to build a pool in her backyard in 5 years, so she decides to set aside a certain amount of money for this purpose. If the average cost of building a pool is \$50,000, how much should she invest into an account with an APR of 8.2% compounded quarterly to reach her goal? Round your answer to the nearest cent.

25. Alexis and Will are purchasing a home. They wish to save money for 10 years and purchase a house that has a value of \$180,000 with cash. If they deposit money into an account paying 12% interest, how much do they need to deposit each month in order to make the purchase?
26. Marilyn wishes to retire at age 65 with \$2,000,000 in the bank. At the age of 21, she decides to begin depositing money into an account with an APR of 11%. What is the monthly payment Marilyn must make in order to make this happen?
27. Suppose you wish to retire at the age of 65 with \$80,000 in savings. Determine your monthly payment into an IRA if the APR is 7.5% and you begin making payments at
- 20 years old.
  - 30 years old.
  - 40 years old.
28. Suppose you'd like to save enough money to pay cash for your next car. The goal is to save an extra \$26,000 over the next 6 years. What amount of quarterly payments must you make into an account that earns 5.5% interest in order to reach your goal?
29. Willie deposits a fixed monthly amount into an annuity account for his child's college fund. He wishes to accumulate a future value of \$75,000 in 15 years.
- Assuming an APR of 3.5%, how much money should Willie deposit monthly in order to reach his goal?
  - How much of the \$75,000 will Willie ultimately deposit in the account, and how much is interest earned?
30. Francis hopes that in 20 years, he will be able to purchase his own house. He estimates the amount of money needed for this will be \$450,000. How much should he deposit each month into an account with an APR of 4.4% compounded monthly to reach his goal? Round your answer to the nearest dollar.
31. Gabriel plans to retire when he has \$1,500,000 in his bank account, and he does not want to work more than 30 years. If his account has an APR of 5.4%, determine the minimum monthly annuity payment he would need to make. Round your answer to the nearest dollar.
32. Sophia has decided to undergo rhinoplasty when she turns 25. She estimates that the procedure will cost about \$8000. Determine the annuity payments she should deposit quarterly into an account with an APR of 3.2% to reach her goal if she is 21. Round your answer to the nearest dollar.
33. Samantha wants to open a clothing store using her own money. She estimates that she will need about \$80,000. How much should she deposit quarterly into an account with an APR of 2.4% in order to accrue enough money in ten years? Round your answer to the nearest dollar.

34. Hasan needs \$1200 to buy a new graphics card for his computer.
- How much should he deposit monthly into an account with an APR of 2.2% to accrue the desired amount in a year? Round your answer to the nearest dollar.
  - How much of the graphics card cost will be deposited by Hasan, and how much will be the interest?
35. Noah has always dreamed of having a yacht. When he was 18, he decided to start saving money to buy one. He learned that the cost of a yacht starts at \$500,000.
- If his goal is to own a yacht by age 30, how much should he deposit each quarter into an account with an APR of 8.7% in order to have enough money to purchase a \$500,000 yacht? Round your answer to the nearest dollar.
  - If he reaches his goal, how much of the \$500,000, will come from deposits, and how much will come from interest?
36. Blake starts an IRA (Individual Retirement Account) to save for retirement at the age of 22. He deposits \$450 each month. The IRA has an average annual interest rate of 7%.
- How much money will he have saved upon retirement at the age of 65?
  - Determine the amount of money Blake deposited over the length of the investment and how much he made in interest.
37. Jimmie has a job at an advertising agency earning \$54,000 per year. Jimmie is currently 26 years old and wishes to retire at age 67 with a retirement income of \$75,000. How much money would Jimmie need to invest each month into a growth stock mutual fund with an interest rate of 6.5% in order to withdraw \$75,000 per year without reducing the principal?
38. After getting married, Liam and Olivia decide to start a shared annuity savings plan. They plan to deposit \$1500 every quarter into an account that earns 2.1% APR compounded quarterly. How much will they have in the account on the day of their Pearl Anniversary, which is the 30th wedding anniversary? Round your answer to the nearest cent.
39. After graduating from college, Ela decides that she wants to start saving so that she can move out of her parents' home and start a new chapter in her life. She starts placing \$90 each month into an account with an APR of 3.4% compounded monthly. How much will she have in her account if she does this faithfully for five years? Round your answer to the nearest cent.
40. When Celine was ten, she asked her parents to start placing \$10 from the money they gave her each month into a savings account. If the account earns 4.1% APR compounded monthly, how much will Celine have when she turns 18? Round your answer to the nearest cent.

41. Alexander had difficulty finding a new job, so he decided to create an emergency fund in case this happened again. He plans to deposit \$2000 every quarter into an account with an APR of 5.8% compounded quarterly. How much will he have in his emergency fund after 10 years? Round your answer to the nearest cent.
42. Elias decided he would go on a trip to Australia when he saved enough money. He started to deposit \$150 each month in an account with an APR of 4.8% compounded monthly.
- How much will he save in three years? Round your answer to the nearest cent.
  - How much of the saved amount will be deposited by Elias, and how much will be the interest?
43. When Mia was 21, she started depositing \$500 each quarter into an account that earns 7.2% APR compounded quarterly.
- Find the future value of her account in 20 years. Round your answer to the nearest cent.
  - Determine how much of the future value Mia will personally put into the account and how much will she earn in interest.
44. When she was 35, Emma started an IRA account with an APR of 7.3% compounded quarterly. Until she turned 50, she contributed \$1400 every quarter. Then, she stopped making deposits and left the account to accrue interest for the next ten years.
- Find the value of the account when Emma was 50.
  - Find the value of the account when she turned 60.
  - How much interest did the account earn until the moment Emma turned 60?
  - According to the four percent rule of thumb, how much could Emma start to withdraw each quarter after she turned 60? Round your answer to the nearest cent.
45. In the first twelve years after opening an IRA account, Hugo deposited \$280 into it every month. After that, he was promoted to a higher position and from then on decided to deposit \$420 each month. The APR for the account is 5.4% compounded monthly.
- Calculate the future value of the account after the first twelve years.
  - Calculate the future value of the account after ten years of increased deposits.
  - How much interest is earned over the twenty-two years?
  - If after twenty-two years Hugo is old enough to not incur any penalties, how much can he start withdrawing each month according to the four percent rule of thumb? Round your answer to the nearest cent.

46. Use the Facebook stock listing in the following table to answer each question.

<b>Facebook Inc. (FB) ↑ 333.65 +0.69 (+0.21%)</b>	
Prev. Close	Open
332.96	329.19
Low	High
325.80	334.38
52wk Low	52wk High
244.69	384.33
Mkt Cap	Volume
938.76B	21,767,335
Avg Vol (3m)	P/E
14,696,273	24.69
EPS (TTM)	Beta
13.49	1.34
1y Target Est	Dividend
419.77	N/A

- What is the ticker symbol for Facebook?
- What is the percentage change in the stock price for the day?
- Does Facebook pay dividends to its shareholders?
- Has the stock price increased or decreased while the market was closed, and by how much?
- Is the number of shares bought and sold for the day greater or less than the average?
- How many shares has Facebook issued?

47. Use the Nike stock listing in the following table to answer each question.

<b>Nike Inc. (NKE) ↓ 148.72 -0.74 (-0.50%)</b>	
Prev. Close	Open
149.46	148.00
Low	High
147.52	149.46
52wk Low	52wk High
118.80	174.38
Mkt Cap	Volume
236.61B	5,512,446
Avg Vol (3m)	P/E
5,910,602	39.70
EPS (TTM)	Beta
3.76	0.89
1y Target Est	Dividend
173.78	1.10 (0.75%)

- a. What is the ticker symbol for Nike?
- b. What is the change in the stock price for the day?
- c. What do analysts predict the price of Nike stock will be in a year?
- d. Has the stock price increased or decreased while the market was closed, and by how much?
- e. How many shares has Nike issued?
- f. How much would you receive in dividends if you owned 70 shares?

 **WRITING & THINKING**

48. Why is it important for the payments in the formula for the future value of an annuity to be made at the end of each compounding interval and not in the middle or any other part of it?
49. If you follow the four percent rule of thumb in the future, will it guarantee that your retirement funds will last through 30 years of retirement?

## 6.2 PROJECT

### PAYOUT ANNUITIES: WHAT HAPPENS AFTER YOU RETIRE?

According to Northwestern Mutual, 56% of adults in the US don't know how much money they will need to save to retire. This can be problematic when setting up your long-term financial goals. In this activity, you will explore a financial instrument, called a payout annuity, that can be used to invest after retirement and maintain a steady income.

Suppose you want to have an after-retirement annual income of \$50,000 for 20 years.

1. Suppose you plan to place your retirement fund into an account that does not earn interest. How much money would you need in the account by the time you retire?

Without further investing, your retirement fund will sit idle when it could be earning interest. A payout annuity provides regular withdrawals while allowing your balance to earn interest. The following formula is used to calculate the value of a payout annuity that compounds annually and has annual withdrawals.

$$P = \frac{d(1 - (1 + r)^{-N})}{r}$$

Here,  $P$  is the starting balance of the account (that is, the size of your retirement fund),  $d$  is the regular annual withdrawal,  $r$  is the annual interest rate as a decimal, and  $N$  is the number of years you plan to take withdrawals.

2. Suppose that you will invest your retirement fund (the value you found in part 1) for 20 years at an interest rate of 7% per year. Up to how much could you withdraw yearly in this case and still meet your goal? In other words, what is the value of  $d$  in the annuity formula in this case?

So after 3 years the total cost of the loan would be as follows.

$$\$773.41 \cdot 36 = \$27,842.76$$

- c. The difference between the overall cost of the loan for the two credit scores is found by subtracting the results found in parts a. and b.

Difference between Loan Costs over 3 Years:

$$\$28,951.92 - \$27,842.76 = \$1,109.16$$

This means that the better credit score would save the borrower \$1,109.16 over the 3-year loan period.

---

### Skill Check Answers

1. \$875.11 2. \$1,031.25 3. \$109,405.33

## 6.3 Exercises

### ✓ CONCEPT CHECK

1. The cash payment made up front towards a total purchase price is called the \_\_\_\_\_.
2. We say that the amount of a purchase that is being borrowed with interest is the amount that needs to be \_\_\_\_\_.
3. A mortgage is an installment loan used to buy real estate where the property is used as \_\_\_\_\_.
4. A loan \_\_\_\_\_ schedule shows how much of each payment is going toward the principal versus how much is going toward interest.
5. Credit cards are common forms of \_\_\_\_\_ loans.

### 💡 PRACTICE

Consider a credit card with a balance of \$7000. You wish to pay off the credit card in each scenario. Calculate the following. Round your answer to the nearest cent, if necessary.

- a. The amount of a monthly payment within the time frame given
  - b. The total amount paid over the time period
6. APR of 17.99% paid off within 1 year
  7. APR of 12.5% paid off within 2 years
  8. APR of 24% paid off within 3 years

Consider a credit card with a balance of \$5560. You wish to pay off the credit card in each scenario. Calculate the following. Round your answer to the nearest cent, if necessary.

- a. The amount of a monthly payment within the time frame given
  - b. The total amount paid over the time period
9. APR of 14.99% paid off within 1 year
  10. APR of 11.99% paid off within 2 years
  11. APR of 5.9% paid off within 3 years
  12. Consider a 30-year fixed-rate mortgage for \$250,000 with a 4.22% APR.
    - a. Prepare a loan amortization schedule for the mortgage.
    - b. What is the balance of the loan after 7 years of payments?
    - c. How many installments (payments) must be made before more than half of the payment is applied to the principal?
  13. Consider a 15-year fixed-rate mortgage for \$325,000 with a 3.19% APR.
    - a. Prepare a loan amortization schedule for the mortgage.
    - b. What is the balance of the loan after 7 years of payments?
    - c. How many installments (payments) must be made before more than half of the payment is applied to the principal?

### APPLICATIONS

14. Suppose you are interested in buying a new condo. You decide to take out a \$200,000 mortgage for 20 years. If the APR is 2.7%, calculate the monthly payment amount you will be responsible for.
15. You want to open your own restaurant, but you don't have enough funds. You take out a small business loan of \$75,000 and commit to repaying the loan within 7 years. The APR you were provided is 8%. Calculate the monthly payment amount you will need to pay to the lender.
16. Ben wants to make repairs in his old house. He's decided to try to do all the work at once instead of gradually, so he takes out a consumer loan of \$25,000. He believes that he will be able to repay the loan in 3 years. If the APR is 4.7%, what will Ben's monthly payment amount be?
17. Samantha needs surgery. To cover the cost, she takes out a loan of \$38,000. The loan was provided for a period of 4 years with an APR of 5.3%. How much does Samantha need to pay monthly for this loan?

18. You need a new laptop and decide to buy it on credit. The price of the laptop is \$2300. You are offered a one-year loan with an interest rate of 6.2%.
- What will be your monthly payment amount?
  - At the end of the loan period, how much will you have paid for the laptop?
19. Sheila is buying a new house. The final price of the house after down payment and fees is \$140,000. She gets a mortgage for 15 years with an interest rate of 2.9%.
- What is her monthly payment amount?
  - At the end of the loan period, how much will she have paid for the house?
20. Mike bought a new car and financed \$25,000 to make the purchase. He financed the car for 60 months with an APR of 6.5%. Determine each of the following.
- Mike's monthly payment
  - Total cost of Mike's car
  - Total interest Mike pays over the life of the loan
21. Omar wants to purchase three vans for his delivery business. Each van costs \$38,000. He wishes to finance the purchase for 48 months and has acquired an APR of 4.5%. Determine each of the following.
- Omar's monthly payment
  - Total cost of Omar's vans
  - Total interest paid by Omar over the life of the loan
22. Jamal bought a new car for \$32,000. He paid a 10% down payment and financed the remaining balance for 36 months with an APR of 4.5%. Determine each of the following.
- Jamal's monthly payment
  - Total cost of Jamal's car
  - Total interest Jamal pays over the life of the loan
23. Susan wants to buy a new computer from Banana Computers. The company sells a laptop model for \$2650. Susan decides to finance the computer for 24 months at an APR of 12.5%. Determine each of the following.
- Susan's monthly payment
  - Total cost of the computer
  - Total interest paid over the 24 months
24. Calculate the monthly payment for a student loan of \$32,000 if the loan is to be repaid over 10 years and the interest rate is 4.2%.
25. Omar borrowed \$26,000 in order to complete his higher education. The term of the student loan is 5 years, and the APR is 6.33%. Calculate Omar's monthly payment amount.

26. After getting a bachelor's degree, Lyna decides to continue her education and get a master's degree. She takes out a student loan of \$25,000. Calculate the monthly payment Lyna will be responsible for if the term of the loan is 7 years with an APR of 8.14%.
27. A pamphlet handed out during student orientation explains that student loans usually have fixed interest rates and don't have to be repaid until a few months after graduation. The pamphlet gives an example of a student loan of \$50,000 that is taken and has to be paid off in 15 years. If the interest rate is 3.67%, what is the monthly payment amount?
28. Tommy gets to choose from one of the new car incentives when he purchases his car next week. He can either choose 0.9% APR financing for 48 months or \$1000 cash back with a 4.75% APR over 48 months. Compare the two incentives that Tommy has to choose from if the new car he wishes to buy is \$32,457 and he has saved a down payment of \$3500.
29. You want to buy a car and finance \$20,000 to do so. You can afford a payment of up to \$450 per month. The bank offers three choices for the loan: a four-year loan with an APR of 7%, a five-year loan with an APR of 7.5%, and a six-year loan with an APR of 8%. Which option best meets your needs, assuming you want to pay the least amount of interest?
30. Suppose you decide to buy a new house for \$270,000. You have saved \$30,000 for a down payment, and want to take out a mortgage for the remaining amount. The lender offers you two possible options.

**Option A:** 2.9% APR financing for 240 months

**Option B:** 3.4% APR financing for 180 months

Compare the offers by determining the monthly payment and the total cost of the house for each option.

31. You want to upgrade your home appliances. You need \$9300 and have saved \$2000 so far. For the rest of the amount, you can take out a consumer loan using one of the following options.

**Option A:** 4.8% APR financing for 24 months

**Option B:** 5.9% APR financing for 18 months

Compare the offers by determining the monthly payment and the total cost for each option.

32. Linda's parents want to gift her a violin as a birthday present. They choose a model that costs \$6250 and make a down payment of \$1000. They are offered two loan options for the remaining amount.

**Option A:** 7.2% APR financing for 18 months

**Option B:** 8.6% APR financing for 12 months

Compare the offers by determining the monthly payment and the total cost of the violin for each option.

33. Mateo is planning to launch a business and needs an initial capital of \$33,000 for his project. He has \$8000 saved and plans to take out a loan for the rest of the amount. Assume that he is offered two options for the loan.

**Option A:** 5.6% APR financing for 84 months

**Option B:** 7.1% APR financing for 60 months

Compare the offers by determining the monthly payment and the total amount Mateo will pay to the lender for each option.

34. A family is going to buy a new house that costs \$195,000. They take out a 30-year fixed-rate mortgage with an APR of 2.857%. The loan requires a down payment of 20% and 1.125 points paid directly to the lender. Additional fees of \$1830 will need to be paid at the time of purchase.
- Calculate the required down payment.
  - Calculate the loan amount.
35. Joseph plans to purchase a house for \$230,000. He is offered a 30-year fixed-rate mortgage with an APR of 3.169% and a down payment of 14%. He will also need to pay 0.915 points to the lender and \$2185 in additional fees.
- Calculate the required down payment.
  - Calculate the loan amount.
36. Amir's parents take out a 30-year fixed-rate mortgage with an APR of 2.934% to purchase a new house. The house costs \$275,000, and the lender requires a down payment of 12%, 1.275 points, and \$2350 in additional fees. Determine the amount Amir's parents can expect to pay at closing.
37. Martha is purchasing a house for \$245,000. She takes out a 30-year fixed-rate mortgage with an APR of 2.968% and a down payment of 16%. The additional fees for the loan are \$3015 and the lender requires 0.995 points. Determine the amount Martha can expect to pay at closing.
38. Luka wants to buy a new house for \$210,000. He plans to take out a 30-year fixed-rate mortgage with an APR of 2.835%. The lender asks him to prepare a down payment of 15% and to pay 1.035 points and \$2080 in additional fees.
- Calculate the monthly payments for the loan, not including taxes and insurance.
  - Calculate Luka's monthly cost, which will include the loan payment, \$180 in property taxes, and \$95.55 in home insurance.

39. Talia is going to purchase a house for \$235,000. She is offered a 30-year fixed-rate mortgage with an APR of 2.916%. A down payment of 16% is required and 0.975 points should be paid directly to the lender. Also, she needs to pay \$2215 in additional fees at closing.
- Calculate the monthly payments for the loan, not including taxes and insurance.
  - Calculate Talia's monthly cost, which will include the loan payment, \$220 in property taxes, and \$81.25 in home insurance.
40. Thomas and Ashley are purchasing a house for \$215,000. They take out a 30-year fixed rate mortgage with an APR of 2.793%. The lender requires a down payment of 18%, 1.125 points paid directly, and \$2350 in additional fees. Determine the total cost of the house at the end of the loan period. Include any closing cost required.
41. Antonio plans to purchase a house that costs \$225,000. He is offered a 30-year fixed-rate mortgage with an APR of 2.896%. A down payment of 15% is required, and 0.975 points should be paid directly to the lender. In addition, Antonio needs to pay \$2735 in closing fees. Determine the total cost of the house at the end of the loan period. Include any closing cost required.
42. Rachel is purchasing a new camera that costs \$3800 for her photography business. Rachel uses a credit card that has an APR of 16.99%.
- How long will it take her to pay off the camera if she makes monthly payments of \$75?
  - How much will she pay in the long run for the camera if she makes monthly payments of \$75?
  - How long will it take her to pay off the camera if she makes monthly payments of \$150?
  - How much will she pay in the long run for the camera if she makes monthly payments of \$150?
43. Trey is going to buy a new couch for his living room. It costs \$1820, and Trey will use a credit card that has an APR of 14.99%.
- Determine how long it will take Trey to pay off the debt if he makes regular monthly payments of \$30.
  - Determine how long it will take Trey to pay off the debt if he makes regular monthly payments of \$80.
  - How much can be saved by making monthly payments at the higher amount?

44. In order to purchase a new TV that costs \$635, Jessica uses a credit card with an APR of 17.33%.
- Determine how long it will take her to pay off the debt if she makes regular monthly payments of \$25.
  - Determine how long it will take her to pay off the debt if she makes regular monthly payments of \$55.
  - How much can be saved by making monthly payments at the higher amount?
45. Assume that Peter needs to borrow \$500 for four weeks in the form of a payday loan. He must pay \$20 per \$100 borrowed as interest. Calculate the APR on the payday loan.
46. Ava is out of money and decides to borrow \$400 for two weeks in the form of a payday loan. The amount of interest she will pay is \$30 per \$100 borrowed. What is the APR on this payday loan?
47. Due to unforeseen circumstances, Mike is going to run out of money before his next paycheck. So, he decides to take out a payday loan of \$600 for two weeks. If he pays \$35 per \$100 borrowed, what is the APR on this loan?
48. Suppose you urgently need money, so you take out a payday loan of \$700 for four weeks. The lender says that the amount of interest you will have to pay is \$40 per \$100 borrowed. Calculate the APR on this payday loan.
49. The following table displays the interest rates for an \$8000 monthly installment loan that should be paid off in 2 years based on a borrower's credit score.

Credit Score	APR
780–850	6.1%
740–779	8.4%
720–739	10.0%
680–719	13.2%
620–679	15.9%
520–619	20.0%

- Determine the overall cost for a borrower with a credit score of 750.
- Determine the overall cost for a borrower with a credit score of 710.
- Compare the costs of the loan for these two borrowers.

50. Suppose you want to borrow \$20,000 for 5 years. The following table displays the interest rates based on a borrower's credit score.

Credit Score	APR
790–850	6.1%
750–789	8.4%
710–749	10.0%
670–709	13.2%
600–699	15.9%
510–599	20.0%

- Determine the overall cost if your credit score is 700.
- Determine the overall cost if your credit score is 760.
- Compare the costs of the loan for these two credit scores.

### WRITING & THINKING

51. What if you won the Powerball Lottery with a jackpot of \$150 million? Calculate the amount of money you would receive over a 25 year period with each of the following two options. Which option gives you the most money over the 25 years?
- Option 1:** Taking all the money at once with a 40% penalty, and pay the income tax of 38% on the lump sum, and investing the remaining amount into an account earning 6% interest for 25 years.
- Option 2:** Acquire the money as part of an annuity to be paid out in 25 equal payments over a 25-year period, paying the income tax of 38% on the income from the winnings each year.
52. Think about a situation when it is better to take out a personal loan than to pay with a credit card.
53. Think about a situation when paying off a loan early may be less profitable than repaying it over time.

## 6.3 PROJECT

### CAR LOANS: BRAND NEW OR PRE-OWNED?

According to the Brookings Institution, approximately 76% of working adults in the United States drive to work alone every day. Since owning a car is a big part of our lives, it is important to understand the true cost involved in a car loan. Brand new cars are more expensive but often can be financed at lower interest rates, while pre-owned vehicles cost less but often require a loan at a higher rate. In this activity, you will explore the difference in cost between financing a new vehicle and a pre-owned one.

Consider two options for purchasing a Honda Fit LX in 2020: one was a brand new 2020 model with a manufacturer's suggested retail price (MSRP) of \$17,945,

**Solution**

- a. For someone who is not self-employed, the FICA Medicare tax rate is 1.45% of the gross income. The pay stub shows that the gross income for the current period is \$3024. So the Medicare tax withheld in this pay period is calculated as follows.

$$\text{FICA Medicare Tax: } \$3024 \cdot 0.0145 \approx \$43.85$$

- b. The FICA Social Security tax rate for employees is 6.2%, for the first \$137,700 of gross income. Since this employee's annual gross income is less than that, the 6.2% tax rate is applied to the entire income earned during the pay period.

$$\text{FICA Social Security Tax: } \$3024 \cdot 0.062 \approx \$187.49$$

- c. The current deductions consist of all the taxes withheld for the current pay period. We need to add together the Medicare tax, the Social Security tax, and the federal income tax (FED TAX).

$$\text{Current Deductions: } \$43.85 + \$187.49 + \$347.08 = \$578.42$$

- d. To find the net pay, we subtract the current deductions from the current total.

$$\text{Net Pay: } \$3024 - \$578.42 = \$2445.58$$

**✓ Skill Check 6.4.3**

Use Table 6.4.4 to calculate the FICA taxes that a self-employed person owed in 2020 if their gross income was \$94,538.

This section provided a brief introduction to federal revenue from individual income taxes and payroll taxes. Federal tax laws and the budget for the United States Government are updated annually. For more information on federal taxes, visit the IRS website [www.irs.gov](http://www.irs.gov). For more information on the United States Government Budget, visit either govinfo at <https://www.govinfo.gov/app/collection/budget> or the Congressional Budget Office at <https://www.cbo.gov/>.

**Skill Check Answers**

1. \$12,400   2. \$2536   3. \$14,464.31

## 6.4 Exercises

**✓ CONCEPT CHECK**

- The form you must fill out each year when you file your income taxes is \_\_\_\_\_.
- What is an example of an expense you can subtract from your gross income to arrive at your adjusted gross income?
- Your taxable income is your adjusted gross income once certain \_\_\_\_\_ have been subtracted.
- Individual income taxes and \_\_\_\_\_ taxes are two of the biggest revenue generators for the federal government.
- True or False: A person's entire taxable income is taxed at the same rate.

 **PRACTICE**

Determine the gross income using the given information.

6. A registered nurse has an annual salary of \$63,458, earned \$125.72 of interest on their savings account, paid \$776 in student loan interest, and contributed \$3600 toward a 401(k).
7. A physical therapist assistant has an annual salary of \$57,410, earned \$723.55 in interest on various investments, paid \$276 in student loan interest, and contributed \$4200 toward an IRA.
8. A computer programmer has an annual salary of \$72,230, earned \$1206.39 in interest on various investments, and contributed \$3600 toward a 401(k).
9. An epidemiologist has an annual salary of \$65,755, earned \$158.23 in interest on a savings account, and contributed \$4000 toward a 401(k).
10. A dental assistant earns \$38,500 per year, paid \$700 in student loan interest, and contributed \$1200 to a 401(k).
11. A paramedic earns \$32,600 per year, earned \$266.32 in interest on various investments, and contributed \$1200 toward an IRA.
12. A middle-school teacher has an annual salary of \$56,250, earned \$52.26 in interest on a savings account, paid \$654.03 in student loan interest, and contributed \$2400 towards an IRA.
  - a. Determine the middle-school teacher's gross income.
  - b. Determine the middle-school teacher's adjusted gross income.
13. An architect has an annual salary of \$78,250, earned \$240.88 in interest on a savings account, paid \$1250 in student loan interest, and contributed \$4800 towards a 401(k).
  - a. Determine the architect's gross income.
  - b. Determine the architect's adjusted gross income.

Use Table 6.4.1 to calculate the total amount of taxes paid by a single taxpayer for the given income amount.

- |              |               |               |
|--------------|---------------|---------------|
| 14. \$32,500 | 15. \$24,800  | 16. \$45,650  |
| 17. \$75,200 | 18. \$175,000 | 19. \$220,700 |

Use the partial 2020 IRS tax worksheet to calculate the amount of federal income tax charged to each taxpayer.

### 2020 Tax Computation Worksheet—Line 16



See the instructions for line 16 to see if you must use the worksheet below to figure your tax.

**Note.** If you are required to use this worksheet to figure the tax on an amount from another form or worksheet, such as the Qualified Dividends and Capital Gain Tax Worksheet, the Schedule D Tax Worksheet, Schedule J, Form 8615, or the Foreign Earned Income Tax Worksheet, enter the amount from that form or worksheet in column (a) of the row that applies to the amount you are looking up. Enter the result on the appropriate line of the form or worksheet that you are completing.

**Section A—** Use if your filing status is **Single**. Complete the row below that applies to you.

Taxable income. If line 15 is—	(a) Enter the amount from line 15	(b) Multiplication amount	(c) Multiply (a) by (b)	(d) Subtraction amount	Tax. Subtract (d) from (c). Enter the result here and on the entry space on line 16.
At least \$100,000 but not over \$163,300	\$	× 24% (0.24)	\$	\$ 5,920.50	\$
Over \$163,300 but not over \$207,350	\$	× 32% (0.32)	\$	\$ 18,984.50	\$
Over \$207,350 but not over \$518,400	\$	× 35% (0.35)	\$	\$ 25,205.00	\$
Over \$518,400	\$	× 37% (0.37)	\$	\$ 35,573.00	\$

**Section B—** Use if your filing status is **Married filing jointly** or **Qualifying widow(er)**. Complete the row below that applies to you.

Taxable income. If line 15 is—	(a) Enter the amount from line 15	(b) Multiplication amount	(c) Multiply (a) by (b)	(d) Subtraction amount	Tax. Subtract (d) from (c). Enter the result here and on the entry space on line 16.
At least \$100,000 but not over \$171,050	\$	× 22% (0.22)	\$	\$ 8,420.00	\$
Over \$171,050 but not over \$326,600	\$	× 24% (0.24)	\$	\$ 11,841.00	\$
Over \$326,600 but not over \$414,700	\$	× 32% (0.32)	\$	\$ 37,969.00	\$
Over \$414,700 but not over \$622,050	\$	× 35% (0.35)	\$	\$ 50,410.00	\$
Over \$622,050	\$	× 37% (0.37)	\$	\$ 62,851.00	\$

20. A single taxpayer with a taxable income of \$110,233
21. A single taxpayer with a taxable income of \$165,755
22. A married taxpayer filing jointly with a taxable income of \$120,824
23. A married taxpayer filing jointly with a taxable income of \$328,100
24. A qualifying widow with a taxable income of \$152,070
25. A qualifying widower with a taxable income of \$322,085
26. A single taxpayer with a taxable income of \$102,780
27. A single taxpayer with a taxable income of \$220,490

Based on the given Form 1040, did the taxpayer receive a federal tax refund or owe an additional amount to the IRS in 2020?

28.

Form 1040 (2020)		Page <b>2</b>
<b>16</b>	Tax (see instructions). Check if any from Form(s): 1 <input type="checkbox"/> 8814 2 <input type="checkbox"/> 4972 3 <input type="checkbox"/>	<b>16</b> 2,814.53
<b>17</b>	Amount from Schedule 2, line 3	<b>17</b>
<b>18</b>	Add lines 16 and 17	<b>18</b> 2,814.53
<b>19</b>	Child tax credit or credit for other dependents	<b>19</b>
<b>20</b>	Amount from Schedule 3, line 7	<b>20</b>
<b>21</b>	Add lines 19 and 20	<b>21</b> 0
<b>22</b>	Subtract line 21 from line 18. If zero or less, enter -0-	<b>22</b> 2,814.53
<b>23</b>	Other taxes, including self-employment tax, from Schedule 2, line 10	<b>23</b>
<b>24</b>	Add lines 22 and 23. This is your <b>total tax</b>	<b>24</b> 2,814.53
<b>25</b>	Federal income tax withheld from:	
<b>a</b>	Form(s) W-2	<b>25a</b> 2,596.17
<b>b</b>	Form(s) 1099	<b>25b</b>
<b>c</b>	Other forms (see instructions)	<b>25c</b>
<b>d</b>	Add lines 25a through 25c	<b>25d</b> 2,596.17
<b>26</b>	2020 estimated tax payments and amount applied from 2019 return	<b>26</b>
<b>27</b>	Earned income credit (EIC)	<b>27</b>
<b>28</b>	Additional child tax credit. Attach Schedule 8812	<b>28</b>
<b>29</b>	American opportunity credit from Form 8863, line 8	<b>29</b>
<b>30</b>	Recovery rebate credit. See instructions	<b>30</b>
<b>31</b>	Amount from Schedule 3, line 13	<b>31</b>
<b>32</b>	Add lines 27 through 31. These are your <b>total other payments and refundable credits</b>	<b>32</b> 0
<b>33</b>	Add lines 25d, 26, and 32. These are your <b>total payments</b>	<b>33</b> 2,596.17
<b>Refund</b>	<b>34</b> If line 33 is more than line 24, subtract line 24 from line 33. This is the amount you <b>overpaid</b>	<b>34</b>
<b>35a</b>	Amount of line 34 you want <b>refunded to you</b> . If Form 8888 is attached, check here <input type="checkbox"/>	<b>35a</b>
<b>b</b>	Routing number	<b>c</b> Type: <input type="checkbox"/> Checking <input type="checkbox"/> Savings
<b>d</b>	Account number	
<b>36</b>	Amount of line 34 you want <b>applied to your 2021 estimated tax</b>	<b>36</b>
<b>Amount You Owe</b>	<b>37</b> Subtract line 33 from line 24. This is the <b>amount you owe now</b>	<b>37</b>
	<b>Note:</b> Schedule H and Schedule SE filers, line 37 may not represent all of the taxes you owe for 2020. See Schedule 3, line 12e, and its instructions for details.	
<b>38</b>	Estimated tax penalty (see instructions)	<b>38</b>

29.

Form 1040 (2020)		Page <b>2</b>
<b>16</b>	Tax (see instructions). Check if any from Form(s): 1 <input type="checkbox"/> 8814 2 <input type="checkbox"/> 4972 3 <input type="checkbox"/>	<b>16</b> 3,765.14
<b>17</b>	Amount from Schedule 2, line 3	<b>17</b>
<b>18</b>	Add lines 16 and 17	<b>18</b> 3,765.14
<b>19</b>	Child tax credit or credit for other dependents	<b>19</b>
<b>20</b>	Amount from Schedule 3, line 7	<b>20</b>
<b>21</b>	Add lines 19 and 20	<b>21</b> 0
<b>22</b>	Subtract line 21 from line 18. If zero or less, enter -0-	<b>22</b> 3,765.14
<b>23</b>	Other taxes, including self-employment tax, from Schedule 2, line 10	<b>23</b>
<b>24</b>	Add lines 22 and 23. This is your <b>total tax</b>	<b>24</b> 3,765.14
<b>25</b>	Federal income tax withheld from:	
<b>a</b>	Form(s) W-2	<b>25a</b> 3,893.59
<b>b</b>	Form(s) 1099	<b>25b</b>
<b>c</b>	Other forms (see instructions)	<b>25c</b>
<b>d</b>	Add lines 25a through 25c	<b>25d</b> 3,893.59
<b>26</b>	2020 estimated tax payments and amount applied from 2019 return	<b>26</b>
<b>27</b>	Earned income credit (EIC)	<b>27</b>
<b>28</b>	Additional child tax credit. Attach Schedule 8812	<b>28</b>
<b>29</b>	American opportunity credit from Form 8863, line 8	<b>29</b>
<b>30</b>	Recovery rebate credit. See instructions	<b>30</b>
<b>31</b>	Amount from Schedule 3, line 13	<b>31</b>
<b>32</b>	Add lines 27 through 31. These are your <b>total other payments and refundable credits</b>	<b>32</b> 0
<b>33</b>	Add lines 25d, 26, and 32. These are your <b>total payments</b>	<b>33</b> 3,893.59
<b>Refund</b>	<b>34</b> If line 33 is more than line 24, subtract line 24 from line 33. This is the amount you <b>overpaid</b>	<b>34</b>
<b>35a</b>	Amount of line 34 you want <b>refunded to you</b> . If Form 8888 is attached, check here <input type="checkbox"/>	<b>35a</b>
<b>b</b>	Routing number	<b>c</b> Type: <input type="checkbox"/> Checking <input type="checkbox"/> Savings
<b>d</b>	Account number	
<b>36</b>	Amount of line 34 you want <b>applied to your 2021 estimated tax</b>	<b>36</b>
<b>Amount You Owe</b>	<b>37</b> Subtract line 33 from line 24. This is the <b>amount you owe now</b>	<b>37</b>
	<b>Note:</b> Schedule H and Schedule SE filers, line 37 may not represent all of the taxes you owe for 2020. See Schedule 3, line 12e, and its instructions for details.	
<b>38</b>	Estimated tax penalty (see instructions)	<b>38</b>

30. A paystub is shown for an employee who has a gross income of \$42,000 annually. Using Table 6.4.4, calculate the missing figures from the paystub, which is for the first pay period of the year.

Barbara's Bombtastic Bakery 1234 Main Street, Cleveland, OH 44105				EARNINGS STATEMENT		
EMPLOYEE NAME	SSN	EMPLOYEE ID	CHECK NO.	PAY PERIOD	PAY DATE	
Sample Employee Name	XXX-XX-1234	0000123456	23131	1/1/20 – 1/31/20	2/4/20	
INCOME	RATE	HOURS	CURRENT TOTAL	DEDUCTIONS	CURRENT TOTAL	YEAR-TO-DATE
GROSS WAGES	21.86	160.11	3500	FICA MED TAX FICA SS TAX FED TAX	a. _____ b. _____ 401.71	401.71
YTD GROSS	YTD DEDUCTIONS	YTD NET PAY	CURRENT TOTAL	CURRENT DEDUCTIONS	NET PAY	
3500			3500	c. _____	d. _____	

31. A paystub is shown for an employee who has a gross income of \$21,600 annually. Using Table 6.4.4, calculate the missing figures from the paystub, which is for the first pay period of the year.

Barbara's Bombtastic Bakery 1234 Main Street, Cleveland, OH 44105				EARNINGS STATEMENT		
EMPLOYEE NAME	SSN	EMPLOYEE ID	CHECK NO.	PAY PERIOD	PAY DATE	
Sample Employee Name	XXX-XX-1234	0000123456	23131	1/1/20 – 1/31/20	2/4/20	
INCOME	RATE	HOURS	CURRENT TOTAL	DEDUCTIONS	CURRENT TOTAL	YEAR-TO-DATE
GROSS WAGES	11.25	160.00	1800	FICA MED TAX FICA SS TAX FED TAX	a. _____ b. _____ 206.59	206.59
YTD GROSS	YTD DEDUCTIONS	YTD NET PAY	CURRENT TOTAL	CURRENT DEDUCTIONS	NET PAY	
1800			1800	c. _____	d. _____	

 APPLICATIONS

Determine the taxable income using the given information. See Appendix B for tax forms.

32. A married taxpayer is filing taxes jointly with his spouse, and they do not have any dependents to claim. During the year, they contribute \$4800 to a traditional IRA. They also make charitable contributions of \$800 to the Wildlife Conservation Society and \$500 to Ronald McDonald House Charities. They have no other deductions, and their combined wages are \$124,938. Additionally, they earned \$374 in interest from their savings accounts, which is taxable.

33. A married taxpayer is filing taxes jointly with her spouse, and they do not have any dependents to claim. During the year, they contribute \$3600 to a traditional IRA. They also make charitable contributions of \$300 to the Conservation Fund, \$250 to the Sheldrick Wildlife Trust, and \$450 to the American Lung Association. They have no other deductions, and their combined wages are \$110,270. Additionally, they earned \$178 in interest from their savings accounts, which is taxable.

34. A single taxpayer is filing taxes and does not have any dependents to claim. During the year, she contributes \$1200 to a traditional IRA. She also makes charitable contributions of \$250 to the Elephant Sanctuary in Tennessee and \$350 to the Parkinson's Foundation. She has no other deductions, and her yearly wage is \$45,640. Additionally, she earned \$92 in interest from her savings accounts, which is taxable.
35. A single taxpayer is filing taxes and does not have any dependents to claim. During the year, they contribute \$1800 to a traditional IRA. They also make charitable contributions of \$400 to the American Red Cross and \$400 to Feeding America. They have no other deductions, and their yearly wage is \$62,700. Additionally, they earned \$256 in interest from their savings accounts, which is taxable.
36. A married taxpayer is filing taxes jointly with his spouse and they do not have any dependents to claim. During the year, they contribute \$3200 to a traditional IRA. They also make charitable contributions of \$125 to Comic Relief, \$500 to ProLiteracy Worldwide, and \$750 to the Alzheimer's Association. They have no other deductions, and their combined wages are \$135,760. Additionally, they earned \$730 in interest from their savings accounts, which is taxable.
37. A qualified widow is filing taxes and does not have any dependents to claim. During the year, she contributes \$4000 to a traditional IRA. She also makes charitable contributions of \$275 to the Trevor Project, \$350 to Give Kids the World, and \$500 to the Gary Sinise Foundation. She has no other deductions, and her yearly wage is \$125,750. Additionally, she earned \$220 in interest from her savings accounts, which is taxable.
38. A married taxpayer is filing taxes separately from his spouse and does not have any dependents to claim. During the year, he contributes \$2400 to a traditional IRA. He also makes charitable contributions of \$175 to the National Council on Aging and \$250 to K9s for Warriors. He has no other deductions, and his yearly wage is \$56,200. Additionally, he earned \$120 in interest from their savings accounts, which is taxable.
39. A single taxpayer is filing taxes and does not have any dependents to claim. During the year, they contribute \$1200 to a traditional IRA. They also make charitable contributions of \$500 to UNCF and \$400 to the Cancer Research Institute. They have no other deductions, and their yearly wage is \$73,000. Additionally, they earned \$351 in interest from their savings accounts, which is taxable.

**WRITING & THINKING**

40. Describe how this section has influenced your view on completing taxes.

Savings	
Personal Insurance/Pensions:	\$10,000
<b>Total</b>	<b>\$10,000</b>

Based on the way we distributed the spending to the different categories, this does not follow a 50/30/20 budget model. The necessities category is way over budget, while the other two are under budget.

Once you have a spending plan for your money and a way to keep track of it, sticking to it is imperative. Luckily, there are lots of different methods to keep you accountable and help you stay on budget. One such method is the *envelope method* or *cash-only method*. This idea has you divide up your take-home pay into the allotted spending categories and put each amount into an envelope (whether literal or virtual) for the month. You only spend what you have. No credit cards allowed. The amount available in the envelope is what you can spend on that category. The strength of the envelope system is in its ability to help prevent overspending in a certain category. If extra money is needed for a category, it literally has to come out of a different envelope or wait until the next paycheck to replenish it. But a warning, if you overspend in one category then you are liable to be short in another category.

Budgeting, like all new endeavors, requires discipline at the beginning. But the key to budgeting is to start. Start simple, and don't feel like you have to figure it out all at once. If you're not careful, the details of your budget have the potential to get too complicated and then you might be inclined to give up, or to drive yourself crazy, or both! Reevaluating your revenue and expenses on a regular basis will always be important and is a habit worth forming.

#### Skill Check Answers

1. \$14.90 2. \$479.33

## 6.5 Exercises

### ✓ CONCEPT CHECK

- When making a budget, the first two things you must consider are your monthly \_\_\_\_\_ and your monthly \_\_\_\_\_.
- The last step of making a budget is to allocate any remaining funds or make \_\_\_\_\_.
- If you have an expense that doesn't come up every month, but you want to set aside a monthly amount to account for that expense, you can \_\_\_\_\_ it.
- According to the 50/30/20 Budgeting Rule, you should allow 50% of your net income for \_\_\_\_\_, no more than 30% for \_\_\_\_\_, and at least 20% for savings and paying down debt.

 **PRACTICE**

Determine the approximate monthly cost of each miscellaneous spending activity. Assume there are 4 weeks in a month.

5. \$3.18 on coffee and a donut three times a week
6. Lunch five days a week, averaging \$11.25 per meal
7. \$16.95 on a paperback novel every Tuesday
8. Groceries every Sunday, averaging \$65.93
9. \$20 on charitable donations, twice a month
10. A tank of gas, averaging \$40.95, three times a month
11. A movie ticket for \$8.70 along with a popcorn and drink for \$11.99 twice a month
12. Dinner with friends, averaging \$24.57, followed by drinks, averaging \$18.45, every Thursday

For each situation, determine the following. Round your answer to the nearest cent, if necessary.

- a. Determine how much the taxpayer should prepay each quarter to meet the projected taxes by the end of the year.
- b. Determine how much the taxpayer should put aside each month in order to have enough to pay their estimated quarterly taxes.
13. Agustin is self-employed. Based on last year, his projected state and federal taxes for this year will be approximately \$18,000.
14. Aya is self-employed. Based on last year, her projected state and federal taxes for this year will be approximately \$21,250.
15. Antonio is self-employed. Based on last year, his projected state and federal taxes for this year will be approximately \$9,700.
16. Alesia is self-employed. Based on last year, her projected state and federal taxes for this year will be approximately \$7,450.

For each situation, prepare a budget using the 50/30/20 rule. Round your answer to the nearest cent, if necessary.

17. After having a child, the MacDonalDs have decided to make an effort to live within their means by creating a budget. Their combined net income is \$5120 a month.
18. The newly married Youngs are combining their finances and making a budget in order to plan for their future. Their combined net income is \$7006 a month.

19. Recent college-graduate Ms. Martin wants to get control of her finances. Her monthly net income is \$2472.
20. After a major promotion, Mr. Lee wants to make sure he doesn't suffer from lifestyle inflation, so he creates a budget. His monthly net income is \$4114.

### APPLICATIONS

For each situation, determine the following. Round your answer to the nearest cent, if necessary.

- a. Determine the monthly net pay amount.
  - b. Determine how much money is left each month for discretionary spending after all necessities are accounted for.
21. A recent college graduate takes an entry-level job as an accountant. His yearly salary is \$32,760. His employer withholds \$4680 in state and federal income taxes and \$2496 in FICA taxes throughout the year. He has the following monthly costs: transportation is \$380, cell phone bill is \$45, student loan payment is \$215, HSA contribution is \$250, and rent is \$650. He is using the average monthly cost for each of the following to gain an idea of other monthly expenses: utilities are \$120, home internet is \$55, and groceries are \$285.
  22. A recent college graduate starts a new job as a middle-school teacher. His yearly salary is \$52,500. His employer withholds \$7872 in state and federal income taxes and \$4008 in FICA taxes throughout the year. He has the following monthly costs: transportation is \$575, cell phone bill is \$80, student loan payment is \$312, retirement fund contribution is \$400, and rent is \$950. He is using the average monthly cost for each of the following to gain an idea of other monthly expenses: utilities are \$165, home internet is \$75, and groceries are \$350.
  23. A recent college graduate acquires a job as a software developer. Her yearly salary is \$65,250. Her employer withholds \$9312 in state and federal income taxes and \$4992 in FICA taxes throughout the year. She has the following monthly costs: transportation is \$560, cell phone bill is \$100, student loan payment is \$280, and rent is \$1150. She is using the average monthly cost for each of the following to gain an idea of other monthly expenses: utilities are \$195, home internet is \$90, health insurance is \$420, and groceries are \$325.
  24. A recent college graduate acquires a job as a civil engineer. Their yearly salary is \$68,750. Their employer withholds \$9312 in state and federal income taxes and \$4992 in FICA taxes throughout the year. They have the following monthly costs: transportation is \$475, cell phone bill is \$60, student loan payment is \$424, HSA contribution is \$180, and rent is \$900. They are using the average monthly cost for each of the following to gain an idea of other monthly expenses: utilities are \$155, home internet is \$85, and groceries are \$300.

**Excel Exercises**

For each situation use a spreadsheet, such as Microsoft Excel, to create a budget. Determine how much is available each month for expenses not listed in the budget. Assume there are 4 weeks in month.

25. A respiratory therapist has an annual income of \$48,700. Their net monthly take-home pay is \$3120, and they have the following monthly expenses. Additional income includes \$80 a week on average from a freelance writing job. A total of \$30 a month is donated to charities.

<b>Monthly Expenses</b>	
Rent	\$950.00
Gas	\$70.00
Water	\$52.00
Electricity	\$112.00
Internet	\$65.00
Cell Phone	\$58.00
Health Insurance	\$320.00
Transportation	\$315.00
Loan Repayment	\$120.00
Food	\$450.00
Credit Card	\$168.00

26. An HR specialist has an annual income of \$52,000. His net monthly take-home pay is \$3302, and he has the following monthly expenses. Additional income includes \$100 a week on average from a dog-walking job. A total of \$50 a month is donated to charities.

<b>Monthly Expenses</b>	
Rent	\$1100.00
Gas	\$155.00
Water	\$65.00
Electricity	\$150.00
Internet	\$80.00
Cell Phone	\$94.00
HSA Contribution	\$250.00
Transportation	\$380.00
Loan Repayment	\$270.00
Food	\$340.00
Credit Card	\$85.00

27. An electrician has an annual income of \$46,500. Their net monthly take-home pay is \$3114, and they have the following monthly expenses. Additional income includes \$75 a week on average from a tutoring job. A total of \$35 a month is donated to charities.

Monthly Expenses	
Rent	\$850.00
Gas	\$320.00
Water	\$56.00
Electricity	\$140.00
Internet	\$62.00
Cell Phone	\$45.00
Health Insurance	\$365.00
Transportation	\$415.00
Food	\$345.00
Credit Card	\$220.00

28. A veterinarian technician has an annual income of \$30,200. Her net monthly take-home pay is \$1990, and she has the following monthly expenses. Additional income includes \$75 a week on average from a dog walking job. A total of \$25 a month is donated to charities.

Monthly Expenses	
Rent	\$700.00
Gas	\$86.00
Water	\$56.00
Electricity	\$150.00
Internet	\$65.00
Cell Phone	\$68.00
Health Insurance	\$220.00
Transportation	\$240.00
Food	\$260.00
Credit Card	\$90.00

29. A market research analyst has an annual income of \$60,300. Her net monthly take-home pay is \$3734, and she has the following monthly expenses. Additional income includes \$100 a week on average from a tutoring job. A total of \$75 a month is donated to charities.

Monthly Expenses	
Mortgage	\$1400.00
Gas	\$160.00
Water	\$86.00
Electricity	\$180.00
Internet	\$90.00
Cell Phone	\$87.00
HSA Contribution	\$240.00
Transportation	\$380.00
Loan Repayment	\$350.00
Food	\$360.00
Credit Card	\$220.00

30. A insurance agent has an annual income of \$44,600. Their net monthly take-home pay is \$2912, and they have the following monthly expenses. Additional income includes \$80 a week on average from a consulting job. A total of \$60 a month is donated to charities.

Monthly Expenses	
Rent	\$985.00
Gas	\$145.00
Water	\$45.00
Electricity	\$112.00
Internet	\$74.00
Cell Phone	\$115.00
Health Insurance	\$275.00
Transportation	\$380.00
Loan Repayment	\$270.00
Food	\$310.00
Credit Card	\$150.00

### WRITING & THINKING

31. Explain the benefits of creating a personal budget.
32. Find four different cell phone plans from at least two different providers. Compare the plans. Pick one plan and explain why it might be best for someone's budget and lifestyle.

## 6.5 PROJECT

### THE COST OF LIVING IN DIFFERENT PARTS OF THE UNITED STATES

The cost of living can vary considerably across the United States. According to the Missouri Economic Research and Information Center, Mississippi offers the lowest average cost of living while Hawaii tops the list as the most expensive state in the nation. In this activity, you will investigate the cost of living in two metropolitan areas.

The figures in the following table represent a reasonable monthly budget for a family of four with two working adults to attain a modest, yet adequate, standard of living in both the Toledo Metro Area in Ohio and in the Providence Metro area in Rhode Island in 2021.

Expense	Toledo, OH	Providence, RI
Housing	\$726	\$1014
Food	\$701	\$798
Child Care	\$1120	\$1659
Transportation	\$1164	\$1112
Health Care	\$895	\$793
Other Necessities	\$576	\$731
Taxes	\$643	\$901
Monthly Total	\$5825	\$7008

In expanded Mayan form, we need  $(7 \cdot 20^1) + (17 \cdot 20^0)$  stacked one on top of the other.



### Skill Check Answers

1. 2,199,270 2. 1312

## 7.1 Exercises

### ✓ CONCEPT CHECK

1. The Hindu-Arabic numeral system uses \_\_\_\_\_ unique symbols to represent all numbers. In contrast, the Babylonian system used only \_\_\_\_\_ unique symbols, and the Mayan system used \_\_\_\_\_ unique symbols.
2. For numbers larger than 59, the Babylonian numeral system uses multiples of \_\_\_\_\_ when writing numbers.
3. When writing the Mayan numeral system, multiples of \_\_\_\_\_ are used.
4. It is widely believed that the Mayan system was the first numeral system to have a symbol to represent \_\_\_\_\_.

### 💡 PRACTICE

Express the Hindu-Arabic numeral in expanded form.

- |          |             |
|----------|-------------|
| 5. 2305  | 6. 4072     |
| 7. 621.9 | 8. 58.63    |
| 9. 80.02 | 10. 710.833 |

Express the expanded form as a Hindu-Arabic numeral.

11.  $(9 \cdot 10^2) + (5 \cdot 10^1) + (4 \cdot 10)$

12.  $(2 \cdot 10^4) + (8 \cdot 10^3) + (8 \cdot 10^2) + (1 \cdot 10^1) + (7 \cdot 1)$

13.  $(3 \cdot 10^5) + (6 \cdot 10^1) + (2 \cdot 1)$

14.  $(5 \cdot 10^3) + (5 \cdot 1)$

15.  $(1 \cdot 10^4) + (2 \cdot 10^2) + (7 \cdot 10^{-2})$

16.  $(4 \cdot 10^2) + (2 \cdot 10^1) + (3 \cdot 10^{-1})$

Write each Babylonian numeral as a Hindu-Arabic numeral.

17.

18.

19.

20.

21.

22.

Write each Hindu-Arabic numeral as a Babylonian numeral.

23. 12

24. 37

25. 99

26. 175

27. 4270

28. 8731

Write each Mayan numeral as a Hindu-Arabic numeral.

29.

30.

31.

32.

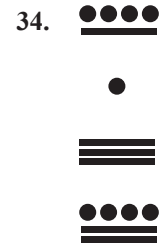
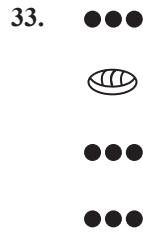

Write each Hindu-Arabic numeral as a Mayan numeral.

35. 15

36. 19

37. 192

38. 261

39. 1335

40. 4807

41. Write the current calendar year using the Babylonian numeral system and then using the Mayan numeral system.

 **WRITING & THINKING**

- 42. List any advantages or disadvantages there might be to using the Babylonian numeration system.
- 43. List any advantages or disadvantages there might be to using the Mayan numeration system.
- 44. Which numeration system would you prefer to use, the Babylonian system or the Mayan system? Discuss why.
- 45. Since the original Babylonian system did not use a symbol or place holder for 0, how do you think they were able to represent the number 60?
- 46. Suppose an ancient manuscript was found that included the Babylonian numeral  $\nabla\nabla$ . The text around the numeral suggests that the manuscript documents a convening of a particular country's government officials and that the number is a record of how many officials were in attendance. Based on the text, how many officials were probably in attendance at the convening?

## ✓ Skill Check 7.2.4

Write the following Chinese numeral as a Hindu-Arabic numeral.

三十五

$$4 = \text{四}$$

$$100 = \text{百}$$

$$0 = \text{零}$$

$$7 = \text{七}$$

$$407 = \text{四百零七}$$

**Skill Check Answers**

1.  2.  $v\beta$  3. XXIV 4. 35

## 7.2 Exercises

## ✓ CONCEPT CHECK

- The ancient Egyptian writing system used symbols called \_\_\_\_\_.
- In the Egyptian numeral system, \_\_\_\_\_ symbols are used to represent multiples of numbers.
- In the Ionic Greek numeral system, a symbol written above \_\_\_\_ means that value is multiplied by 10,000.
- Unlike previous systems studied, the Roman numeral system involves \_\_\_\_\_.
- In the Chinese numeral system, formal characters are used because the simple characters can be easily \_\_\_\_\_.

## 💡 PRACTICE

Write each Egyptian numeral as a Hindu-Arabic numeral.

6. 

7. 

8. 



Write each Hindu-Arabic numeral using Egyptian hieroglyphics.

12. 435,072

13. 1128

14. 2,601,011

15. 50,000

16. 71,614

17. 1,003,050

Write each Ionic Greek numeral as a Hindu-Arabic numeral.

18.  $\lambda \varepsilon$

19.  $\nu \mu \delta$

20.  $\omega \gamma$

21.  $\tau \alpha$

22.  $\zeta \rho \iota$

23.  $\eta \phi \nu \varepsilon$

24.  $\gamma$   
M

25.  $\theta \omega \theta$   
M

Write each Hindu-Arabic numeral as an Ionic Greek numeral.

26. 284

27. 196

28. 2000

29. 1078

30. 50,000

31. 80,424

Write each Roman numeral as a Hindu-Arabic numeral.

32. XXVII

33. XLVIII

34. CCXIX

35. DCLI

36. MCDIV

37. CMLXXV

Write each Hindu-Arabic numeral as a Roman numeral.

38. 35

39. 42

40. 79

41. 163

42. 558

43. 491

Write each Chinese numerals as a Hindu-Arabic numeral.

44. 十六

45. 五十四

46. 七百九十二

47. 一千零八

48. 三千五百二十一

49. 二万五千五百七十五

Write each Hindu-Arabic numeral as a Chinese numeral.

50. 26

51. 103

52. 82

53. 75

54. 649

55. 2002

56. Write today's calendar year using the Egyptian numeral system.
57. Write today's calendar year using the Ionic Greek numeral system.
58. Write today's calendar year using the Roman numeral system.
59. Write today's calendar year using the Chinese numeral system.

 **WRITING & THINKING**

60. One of the peculiarities with the Ionic Greek system is that numbers often look like words and vice versa, since the Greek alphabet is used to write numerals. Determine the number that these phonetic spellings also make.
  - a. dog =  $\delta\omega\gamma$
  - b. bird =  $\beta\iota\rho\delta$
  - c. star =  $\sigma\tau\alpha\rho$
  - d. rain =  $\rho\alpha\iota\nu$
61. Super Bowl LII was played on February 4, 2018, and featured the Philadelphia Eagles against the New England Patriots. The Eagles won the championship by a score of 41 to 33.
  - a. What number Super Bowl are the Philadelphia Eagles be able to boast about winning?
  - b. Why do you think we use Roman numerals to number the Super Bowl championship games and not our Hindu-Arabic numbers?
  - c. Why is an ancient European system used to name the super bowl instead of an ancient American system?
62. The 2024 Summer Olympics will be held in Paris from July 26 through August 11. The games are officially known as the Games of the XXXIII Olympiad.
  - a. What number Olympiad will these games be?
  - b. Why do you think we use Roman numerals to number the Olympics games and not Ionic Greek numerals since the Greeks started the Olympics?
63. Name at least one weakness of the Egyptian numeral system.
64. Explain why the absence of a zero is not as problematic in the Ionic Greek system as it is in the Babylonian system.
65. Which of the four numeral systems covered in this section do you find the easiest to write numbers in? Why?

$$\begin{array}{r}
 102_3 \quad 2 \times 1 = 2_3 \\
 \times 21_3 \quad \text{No conversion necessary.} \\
 \hline
 102_3 \\
 2110_3
 \end{array}$$

Now we can add the two products together to find the answer, converting any values back into base 3, if necessary.

$$\begin{array}{r}
 102_3 \\
 \times 21_3 \\
 \hline
 102_3 \\
 +2110_3 \\
 \hline
 2212_3
 \end{array}$$

### ✓ Skill Check 7.3.5

Multiply  $D_{16}$  and  $8_{16}$

So  $102_3$  multiplied by  $21_3$  is equal to  $2212_3$ .

### Skill Check Answers

1. 108

$$\begin{aligned}
 2. 111100100011000000_2 &= (1 \cdot 2^{17}) + (1 \cdot 2^{16}) + (1 \cdot 2^{15}) + (1 \cdot 2^{14}) + (1 \cdot 2^{11}) + (1 \cdot 2^7) + (1 \cdot 2^6) \\
 &= 131,072 + 65,536 + 32,768 + 16,384 + 2048 + 128 + 64 \\
 &= 248,000
 \end{aligned}$$

$$\begin{aligned}
 3C8C0_{16} &= (3 \cdot 16^4) + (12 \cdot 16^3) + (8 \cdot 16^2) + (12 \cdot 16^1) \\
 &= 196,608 + 49,152 + 2048 + 192 \\
 &= 248,000
 \end{aligned}$$

3.  $1000_2$  4.  $20_3$  5.  $688_{16}$

## 7.3 Exercises

### ✓ CONCEPT CHECK

- The Hindu-Arabic numeration system is in base \_\_\_\_\_.
- The number 1348 is written in base \_\_\_\_\_.
- The hexadecimal system uses \_\_\_\_\_ to represent the digits 10 through 15.
- Numbers in base 2 and base 16 are often used in \_\_\_\_\_.
- In the Hindu-Arabic numeration system, the 4th digit represents the \_\_\_\_\_ place. In the base 2 system, the 4th digit represents the \_\_\_\_\_ place.

 **PRACTICE**

Convert each number to base 10.

- |                    |                |              |
|--------------------|----------------|--------------|
| 6. $201_3$         | 7. $4444_5$    | 8. $11011_2$ |
| 9. $10101010100_2$ | 10. $5301_6$   | 11. $1001_8$ |
| 12. $AB_{16}$      | 13. $6D8_{16}$ |              |
14. Which is larger,  $1111001000110001100_2$  or  $A9CFE_{16}$ ?
15. Which is larger,  $BB_{16}$  or  $60_{32}$ ?

Convert each base 10 number to the indicated base.

- |                    |                    |
|--------------------|--------------------|
| 16. 52 to base 2   | 17. 1000 to base 3 |
| 18. 2000 to base 5 | 19. 48 to base 12  |
| 20. 66 to base 12  | 21. 700 to base 2  |
| 22. 256 to base 8  | 23. 542 to base 16 |

Convert each base 2 number to base 16.

- |                          |                          |
|--------------------------|--------------------------|
| 24. $10001_2$            | 25. $111011_2$           |
| 26. $1010101101_2$       | 27. $111001011100_2$     |
| 28. $1000100010101100_2$ | 29. $1011000000111000_2$ |

Covert each base 16 number to base 2.

- |                  |                  |
|------------------|------------------|
| 30. $17_{16}$    | 31. $3D_{16}$    |
| 32. $CAB_{16}$   | 33. $FED_{16}$   |
| 34. $A79B2_{16}$ | 35. $3D095_{16}$ |

Perform the indicated operations.

36. Add the numbers  $155_8$  and  $72_8$ .
37. Add the numbers  $63_7$  and  $51_7$ .
38. Add the numbers  $221_5$  and  $24_5$ .
39. Add the numbers  $101_2$  and  $111_2$ .
40. Add the numbers  $1222_3$  and  $201_3$ .
41. Add the numbers  $45231_6$  and  $1432_6$ .

42. Subtract the number  $10_8$  from  $34_8$ .
43. Subtract the number  $41_9$  from  $324_9$ .
44. Subtract the number  $110011_2$  from  $110110110_2$ .
45. Subtract the number  $42A_{16}$  from  $C0F_{16}$ .
46. Subtract the number  $506_7$  from  $2135_7$ .
47. Subtract the number  $2243_5$  from  $4000_5$ .
48. Multiply  $155_7$  and  $3_7$ .
49. Multiply  $22_3$  and  $10_3$ .
50. Multiply  $510_8$  and  $10_8$ .
51. Multiply  $12_4$  and  $31_4$ .
52. Multiply  $24_5$  and  $11_5$ .
53. Multiply  $3A_{16}$  and  $4_{16}$ .
54. An addition table for numbers in base 5 is shown. Fill in the missing numbers. Assume all numbers in the table are in base 5.

<b>+</b> <b>Base 5</b>	<b>0</b>	<b>1</b>	<b>2</b>	<b>3</b>	<b>4</b>
0	0	1	2	3	4
1	1				
2	2				11
3	3		10		
4	4				

55. An addition table for numbers in base 8 is shown. Fill in the missing numbers. Assume all numbers in the table are in base 8.

<b>+</b> <b>Base 8</b>	<b>0</b>	<b>1</b>	<b>2</b>	<b>3</b>	<b>4</b>	<b>5</b>	<b>6</b>	<b>7</b>
0	0	1	2	3	4	5	6	7
1			3		5			
2	2							
3		4					11	
4		5		7	10			
5	5							
6		7						
7		10						

56. An addition table for numbers in base 12 is shown. Fill in the missing numbers. Assume all numbers in the table are in base 12, which uses the digits 0, 1, 2, 3, 4, 5, 6, 7, 8, 9, A, B.

<b>+</b> <b>Base 12</b>	0	1	2	3	4	5	6	7	8	9	10	11
0	0	1	2	3	4	5	6	7	8	9	A	B
1		2										
2			4									
3			5									
4			6				A					
5			7		9							
6			8									15
7		8			B							
8				B								
9									15			
10	A											
11								16				

57. A multiplication table for numbers in base 4 is shown. Fill in the missing numbers. Assume all numbers in the table are in base 4.

<b>×</b> <b>Base 4</b>	0	1	2	3
0	0	0	0	0
1	0		2	
2	0			12
3	0	3		

58. The following table is a multiplication table for numbers in base 5. Fill in the missing numbers. Assume the numbers in the table are in base 5.

<b>×</b> <b>Base 5</b>	0	1	2	3	4
0	0	0	0	0	0
1	0				
2	0		4		13
3	0	3			
4				22	

59. A multiplication table for numbers in base 7 is shown. Fill in the missing numbers. Assume all numbers in the table are in base 7.

× Base 7	0	1	2	3	4	5	6
0	0	0			0	0	0
1			2	3			
2							
3	0				15		
4		4					
5		5				34	
6	0						

 **WRITING & THINKING**

60. Describe one way to convert a number in base 2 to base 16.
61. A piece of an addition table that was in the process of being completed is shown. Based on the information that you have, determine which base is being used for the addition. Assume all numbers in the table are in the necessary base.

		2	3	4	
		2	3	4	
		3	4		
2	0		4	5	10
3	0	3	5	10	11
			10	11	12

62. A piece of an addition table that was in the process of being completed is shown. Based on the information that you have, determine which base is being used for the addition. Assume all numbers in the table are in the necessary base.

			5	6	7
				6	7
			6	7	8
					10
			8		11
			10		12
				12	

63. A piece of a multiplication table that was in the process of being completed is shown. Based on the information that you have, determine which base is being used for the multiplication. Assume all numbers in the table are in the necessary base.

		4	5	6
			0	0
		4	5	6
		10	12	14
		20		

## 7.3 PROJECT

### THE BAKER'S DOZEN

In the sixteenth century, bakers in the United Kingdom who sold their goods by the dozen (12 items) were obligated to meet specific weight and quality standards. Failing to do so was considered a crime. To avoid punishment, it became a common practice to include an additional item with the dozen purchased to assure the law was properly obeyed. This became known as the baker's dozen.

One particular baker served six customers: Anne, Elinor, Giles, Lancelot, Rose, and Florence. The baker placed their orders on the counter and asked them to verify that their orders were correct and that the orders were, indeed, a baker's dozen each.

Anne nodded her head and confirmed, "Yes. 13." The other five nodded as well. Elinor said, "15 exactly!" Giles smiled, "23 for me. Perfect." Lancelot added, "1101 here. Thank you!" Rose happily counted, "10 for me! Yum!" Finally, Florence, about to sample a morsel, gave a thumbs up and said, "11. I love a baker's dozen!"

The baker looked confused. He knew he had put exactly the same number of items in each customer's box. As the pleased clients left the bakery, the solution to the puzzle dawned on him.

1. Explain the apparent contradiction with the numbers and how each customer arrived at their count. Be sure to support your explanation with useful mathematical expressions and equations.

Later that day, the baker asked his assistant to count the remaining inventory and determine how many items they sold during the day. The assistant counted that there were 22 items left in the inventory. The baker knew they started with 175 items and said, "We've sold 159 items today!" His assistant replied with "No! We sold 243 today."

2. Explain how both the baker and his assistant are correct.

**Solution**

- a. To begin, we need to find the area of land by multiplying the lengths together.

$$\text{area} = 110 \text{ m} \cdot 150 \text{ m} = 16\,500 \text{ m}^2$$

We can now use the conversion factor  $\frac{1 \text{ ha}}{10\,000 \text{ m}^2}$  to convert squared meters into hectares.

$$16\,500 \text{ m}^2 = 16\,500 \cancel{\text{m}^2} \cdot \frac{1 \text{ ha}}{10\,000 \cancel{\text{m}^2}} = 1.65 \text{ ha}$$

Therefore, the land is 1.65 hectares.

- b. We need to use the conversion factor  $\frac{1 \text{ L}}{1000 \text{ cm}^3}$  to convert cubic centimeters into liters.

$$5500 \text{ cm}^3 = 5500 \cancel{\text{cm}^3} \cdot \frac{1 \text{ L}}{1000 \cancel{\text{cm}^3}} = 5.5 \text{ L}$$

So, the bowl can hold 5.5 liters of punch.

**Skill Check Answers**

1. 2.5 feet   2. 1.5 liters   3. 0.022 m<sup>2</sup>

## 7.4 Exercises

**✓ CONCEPT CHECK**

- Conversion factors are always equal to \_\_\_\_\_.
- The \_\_\_\_\_ is the measurement system used in most of the world.
- The unit for volume in the metric system is the \_\_\_\_\_.
- Conversions within the metric system are based on powers of \_\_\_\_\_.
- One \_\_\_\_\_ is equivalent to 100 m<sup>2</sup>.

**💡 PRACTICE**

Convert each measurement to the desired unit of measure.

- |                        |                               |
|------------------------|-------------------------------|
| 6. 2232 in. = _____ yd | 7. 13 ft = _____ in.          |
| 8. 22 lb = _____ oz    | 9. 120 oz = _____ lb _____ oz |

10. 200 fl oz = \_\_\_\_\_ cups
11. 5 qt = \_\_\_\_\_ pt
12. 1008 min = \_\_\_\_\_ days
13. 4.25 hours = \_\_\_\_\_ minutes
14. 262 yd = \_\_\_\_\_ mi
15. 3.5 mi = \_\_\_\_\_ ft
16. 15.5 gal = \_\_\_\_\_ pt
17. 4 pt = \_\_\_\_\_ fl oz
18. 11 acres = \_\_\_\_\_  $\text{yd}^2$
19. 1000 acres = \_\_\_\_\_  $\text{mi}^2$
20. How many centimeters are in 364 km?
21. Convert 230 m to kilometers.
22. Convert 0.87 km to centimeters.
23. How many meters are in 123 cm?
24. Convert 21 mm to decimeters.
25. How many kiloliters are in 35 600 cL?
26. Convert 7.22 hL to milliliters.
27. How many grams are in 1.2 kg?
28. Convert 45 422 cg to dekagrams.
29. How many square decimeters are in  $726 \text{ m}^2$ ?
30. Express  $40.93 \text{ m}^2$  in square kilometers.
31. How many square centimeters are in  $627.2 \text{ m}^2$ ?
32. How many square millimeters are in  $928 \text{ cm}^2$ ?
33. How many cubic centimeters are in  $99 \text{ m}^3$ ?
34. Express  $8503 \text{ mm}^3$  in cubic meters.
35. Convert  $345 \text{ m}^2$  to ares.
36. How many square meters are in 1.72 ares?

 **APPLICATIONS**

37. Men ages 19 to 30 are recommended to intake about 13 cups of water a day. Calculate the number of fluid ounces this would be per day. Round your answer to the nearest tenth, if necessary.
38. A Louisiana gumbo recipe calls for 14.5 ounces of stewed tomatoes. How many cups of stewed tomatoes are required? Round your answer to the nearest tenth, if necessary.

$34\frac{1}{2}$ 

39. A king-size mattress is 76 inches wide by 80 inches long. If a queen-size mattress is 5 feet wide and about 6.7 feet long, how much wider (in inches) is the king-size mattress than the queen-size mattress?
40. An online gaming company reports that the average player has spent 832 hours on their sight. Assuming their report is correct, how many days has the average player spent on the gaming sight? Round to the nearest half a day.
41. A local coffee shop is calculating the number of gallons of coffee they sell per day. On average, the shop sells two hundred sixty 16 fl oz cups of coffee a day. How many gallons of coffee per day do they sell?
42. A freight train measures 1.3 miles long when all boxcars are attached. If a standard boxcar is 55 feet 5 inches long, what is the maximum number of boxcars the freight train contains?
43. The outer lane (lane 8) of a running track is 453.66 meters compared to the inside lane (lane 1) which has a length of 400 meters. If a runner makes three complete laps around the track in lane 8, how many kilometers has he run? Round your answer to two decimal places.
44. A paper clip is made from galvanized steel wire. When curled, the paperclip measures 4.1 cm in length. Uncurled, it measures 108 mm. What is the maximum number of paper clips that can be made from a straight piece of wire that is 100 m long? Round your answer to the nearest number of whole paperclips.
45. Alex is buying a bag of apples that weighs 720 grams. If the apples are sold for \$3.34 per kilogram, how much will Alex pay for the bag of apples? Round your answer to the nearest cent.
46. Forty centigrams of caffeine per day is considered a safe amount. If there are 95 mg of caffeine in one cup of coffee, what is the maximum number of cups of coffee you can drink in a day and stay under the safe amount of caffeine?
47. Trey is reupholstering his dining room chairs. He plans to place brass upholstery tacks every 2 cm along the back edge of the chair. If the back measures 4.45 dm in length, how many tacks will he need for each chair?
48. To help encourage the safe use of acetaminophen, the maximum daily dose has been reduced from 4 g per day to 3 g per day. If an extra strength tablet contains 500 mg of acetaminophen, how many tablets make up the new maximum daily dose?
49. A rectangular plot of land measures 180 m by 50 m. How many hectares is the plot of land?
50. A community garden is being planned. The garden will measure 52 m by 23 m. Calculate the size of the garden in ares.
51. A small fish tank holds 19 liters of water. How many cubic centimeters of water does the tank hold?

52. The Sawyers' water heater broke, and they need to purchase a new one. Their current water heater holds  $120\,000\text{ cm}^3$  of water. If a new water heater is available in capacities of 30 L, 100 L, and 140 L, which size heater should the Sawyers purchase if they want to buy one that is at least as big as the old one.

 **WRITING & THINKING**

53. What metric unit of length would be best to measure the depth of the Pacific Ocean? Explain your reasoning.
54. What metric unit of length would be best to measure the length of a room? Explain your reasoning.
55. What metric unit of length would be best to measure the thickness of a smartphone? Explain your reasoning.
56. What metric unit would be the best choice to measure the mass of a grain of rice? Explain your reasoning.
57. Rank the following mass measurements from smallest to largest:  
 $100.6\text{ mg}$     $1021\text{ g}$     $0.0000006\text{ kg}$     $0.61\text{ mg}$
58. Rank the following length measurements from smallest to largest:  
 $3.4\text{ dm}$     $0.341\text{ dam}$     $0.0000034\text{ km}$     $34\text{ m}$

b. To convert to Celsius, Whitley must use the formula  $C = \frac{5(F-32)}{9}$ .

$$C = \frac{5(425-32)}{9} \quad \text{Make the appropriate substitution.}$$

$$C = \frac{1965}{9} \quad \text{Simplify.}$$

$$C = 218.\overline{3}$$

Therefore, Whitley needs to set the oven to approximately 218 °C.

#### ✓ Skill Check 7.5.4

Convert 68 °F to °C.

#### Skill Check Answers

1. 4.70 yards   2. 59.06 inches   3. 0.02 lb/in.   4. 20 °C

## 7.5 Exercises

### ✓ CONCEPT CHECK

- Temperature, time, and length are examples of different physical \_\_\_\_\_.
- The relationship between different physical quantities of the same dimension can be compared using \_\_\_\_\_.
- Conversion factors are typically \_\_\_\_\_.
- The two most common units for measuring temperature are degrees \_\_\_\_\_ and degrees \_\_\_\_\_.
- One inch is equal to exactly \_\_\_\_\_ centimeters.

### 💡 PRACTICE

Convert each measurement using the appropriate conversion factor. Round your answer to the nearest thousandth, if necessary. Note that answers may vary depending on the conversion factor used.

- Convert 52 centimeters to inches.
- Convert 150 miles to kilometers.
- What number of yards is equivalent to 800 m?
- What number of meters is equivalent to 150 ft?
- Convert 200 ft<sup>2</sup> to square centimeters.

11. Convert 12 ha to acres.
12. What number of square yards is equivalent to  $40 \text{ m}^2$ ?
13. What number of square kilometers is equivalent to  $20 \text{ mi}^2$ ?
14.  $40 \text{ lb} = \underline{\hspace{2cm}} \text{ kg}$
15.  $35 \text{ g} = \underline{\hspace{2cm}} \text{ oz}$
16. Convert 22 kg to pounds.
17. Convert 42 oz to grams.
18.  $16 \text{ c} = \underline{\hspace{2cm}} \text{ L}$
19.  $6 \text{ L} = \underline{\hspace{2cm}} \text{ gal}$
20. Convert  $800 \text{ in.}^3$  to cubic meters.
21. Convert 100 mL to tablespoons.
22. Convert 198.1 ft to centimeters.
23. What number of inches is equivalent to 760.82 km?
24. 21 ft/sec to m/min
25. 50 km/hr to mi/min
26. 1.35 g/mL to lb/gal
27. 3 oz/cup to g/L
28. 5.22 g/cm to lb/in.
29. 4.6 g/cm to lb/ft
30.  $240 \text{ ft}^2/\text{gal}$  to  $\text{m}^2/\text{L}$
31.  $25 \text{ m}^2/\text{kg}$  to  $\text{yd}^2/\text{lb}$
32.  $45 \text{ }^\circ\text{C} = \underline{\hspace{2cm}} \text{ }^\circ\text{F}$
33.  $177 \text{ }^\circ\text{C} = \underline{\hspace{2cm}} \text{ }^\circ\text{F}$
34.  $-40 \text{ }^\circ\text{F} = \underline{\hspace{2cm}} \text{ }^\circ\text{C}$
35.  $275 \text{ }^\circ\text{F} = \underline{\hspace{2cm}} \text{ }^\circ\text{C}$
36. What is  $16 \text{ }^\circ\text{C}$  in degrees Fahrenheit?
37. What is  $25 \text{ }^\circ\text{C}$  in degrees Fahrenheit?

38. Convert 100 °F into degrees Celsius.
39. Convert 12 °F into degrees Celsius.
40. Rank the following mass measurements from smallest to largest:  
2 oz 18 kg 50g 2 lb 35 mg
41. Rank the following length measurements from smallest to largest:  
100 yd 100 m 10 km 10 mi 10 ft 100 cm 100 in.

### APPLICATIONS

42. The density of mercury is 13.56 g/mL. What is its density in lb/ft<sup>3</sup>?
43. The density of gold is 19.32 g/cm<sup>3</sup>. What is its density in lb/ft<sup>3</sup>?
44. A toilet flushes with a pressure of 1.6 gal/ft. What is the pressure in SI units (m/L)?
45. A domestic pressure washer sprays water at a rate of 3 GPM (gal/min). What is the spray rate in L/sec?
46. A gas station is charging \$2.299 per gallon of gas. What would be the price for a liter of gas?
47. The sign on a freeway in Canada indicates that the speed limit is 100 km/hr. What would the speed limit be in miles per hour?
48. Allison buys embroidery thread for sewing. There are 8.7 yards of thread in each skein. She uses 1 meter. How much thread is left in the skein in meters? Round your answer to the nearest thousandth, if necessary.
49. Suppose it takes John 7 minutes to run 1 mile. How long would it take him to run 3 kilometers? Round your answer to the nearest minute.
50. A website for a new European Low Carb diet provides recipes using metric units of measurement. Convert each ingredient to the indicated measurement. Round to the nearest tenth, if necessary.
- 5 mL of vanilla = \_\_\_\_\_ tsp
  - 30 g of ground flax = \_\_\_\_\_ oz
  - 25 g of almond flour = \_\_\_\_\_ oz
51. A French recipe for Pain au Chocolat calls for 120 mL of milk and needs the oven preheated to 190 °C. You only have measuring cups in fluid ounces and Fahrenheit on your oven temperature dial. Determine the amount of milk needed in fluid ounces and the temperature for the oven in Fahrenheit. Round your answer to the nearest tenth, if necessary. (**Note:** There are 8 fluid ounces per cup.)

52. The medicine bottle says to take 5 teaspoons every four hours, but your medicine cup only has milliliters. How many milliliters do you need to take?
53. Sandra is on vacation. The hotel clerk at the ski resort tells her that the high temperature for tomorrow is going to be  $-7^{\circ}\text{C}$ . How many degrees Fahrenheit is it going to be?
54. Matt is looking to purchase a new car. The sticker says that the car has an average fuel economy of 18 km/L. How many miles per gallon is that?
55. Logan has made 97 pints of maple syrup. A buyer has offered him \$37.28 per gallon. How many gallons does he have made, and how much money will he make if he the buyer purchases all of the maple syrup?
56. The directions for a drink mix say to add 8 teaspoons of sugar for every gallon of liquid. If Sam has 7.6 liters of liquid, how many teaspoons of sugar should he add?
57. Jeff built a model sailboat that can move at a maximum speed of 8 ft/sec. How fast can his sailboat in miles per hour?
58. John's model sailboat can move at a maximum speed of 90 m/min. Whose model sailboat is faster Jeff's or John's, and how much faster is it?

**WRITING & THINKING**

59. Carlos was trying to make his grandmother's Christmas cinnamon stars called zimtsternes.

The ingredient conversions calculated by Carlos are shown here.

350 g unblanched almonds  $\rightarrow$  12 oz unblanched almonds

400 g icing sugar  $\rightarrow$  13 oz icing sugar

22.5 mL ground cinnamon  $\rightarrow$  3 tbsp ground cinnamon

The recipe says to bake them at  $140^{\circ}\text{C}$  for 20 to 30 minutes. Unfortunately, Carlos did not notice the temperature was given in Celsius and baked them at  $140^{\circ}\text{F}$ . Would you eat these cookies? Explain your answer and include the conversions you based your decision on.

60. When using dimensional analysis with several conversion factors, would it be best to round during intermediate steps or wait until the end of the calculation to round? Explain your reasoning.

## 8.1 Exercises

### ✓ CONCEPT CHECK

1. If a number is divisible by 2 and 3, then it is also divisible by \_\_\_\_.
2. If a number is even, then it is divisible by \_\_\_\_.
3. True or False: 1 is a prime number.
4. True or False: A composite number is a positive integer with two or more divisors.

### 💡 PRACTICE

Determine whether each of the numbers is prime or composite.

- |               |         |
|---------------|---------|
| 5. 245        | 6. 939  |
| 7. 149        | 8. 4372 |
| 9. 68,045,800 | 10. 113 |
| 11. 51        | 12. 79  |
| 13. 91        | 14. 147 |

Determine the prime factorization of each number.

- |         |         |
|---------|---------|
| 15. 16  | 16. 124 |
| 17. 162 | 18. 630 |
| 19. 625 | 20. 72  |
| 21. 105 | 22. 81  |

Use a factor tree to determine the greatest common divisor of each pair of numbers.

- |                 |                 |
|-----------------|-----------------|
| 23. 35 and 14   | 24. 28 and 42   |
| 25. 90 and 225  | 26. 350 and 217 |
| 27. 36 and 72   | 28. 36 and 54   |
| 29. 175 and 245 | 30. 360 and 216 |

Use Euclid's Algorithm to find the greatest common divisor of each pair of numbers.

- |                   |                  |
|-------------------|------------------|
| 31. 357 and 217   | 32. 350 and 140  |
| 33. 1235 and 5687 | 34. 1556 and 236 |
| 35. 2216 and 1008 | 36. 288 and 672  |
| 37. 894 and 204   | 38. 225 and 121  |

Use Euclid's Algorithm to determine whether each pair of numbers is relatively prime.

- |                  |                   |
|------------------|-------------------|
| 39. 67 and 17    | 40. 1231 and 5673 |
| 41. 351 and 141  | 42. 289 and 169   |
| 43. 39 and 51    | 44. 133 and 153   |
| 45. 428 and 1284 | 46. 1084 and 1444 |

### APPLICATIONS

47. There are 16 cellists, 32 violinists, 24 flautists, and 16 violists at a summer classical music camp.
- What is the largest number of identical groups that can be made from all of the musicians?
  - How many violinists will be in each group?
  - How many campers will be left without a group?
48. Berrylin was asked to make flower arrangements for the tables at a sports banquet. She was given 36 tulips, 27 daisies, and 18 carnations.
- What is the largest number of identical arrangements that Berrylin can make from all of the flowers?
  - How many of each flower will be put into each arrangement?
49. Phillip's Bakery gives away any remaining items at the end of the day to local hunger organizations. Today they had 39 loaves of bread and 86 cookies left. Bill is allowed to take some of the food home himself because he volunteers to box the goods each day. If he plans to take 3 loaves of bread and 10 cookies home, how many boxes will Bill fill given that each box must contain the same number of loaves of bread and cookies?

50. The library received 117 used books for their summer used book drive this year. There were 45 hardbacks and 72 paperbacks. The library delivers the books in bundles to local shelters.
- How many bundles can the library make if each bundle must have the same number of hardback and paperback books?
  - How many paperback books will be in each bundle?
51. Two girl scout troops are planting gardens side-by-side on donated land. Based on the number of girls, Troop A is planning a garden that will cover 180 square feet, and Troop B's garden will be 204 square feet. The gardens must have a fence completely surrounding each one. The fencing is only sold in whole foot sections. In order to save money, the troops decide to maximize the shared amount of fence between the gardens.
- What is the greatest amount of fence the troops can share?
  - What will the dimensions of each garden be if the shared fencing is maximized?

 **WRITING & THINKING**

52. Which possible divisors must be checked to see if 283 is prime?
53. Which possible divisors must be checked to see if 1291 is prime?
54. Suppose you are choosing the size of an elementary school class. It must be between 15 and 20 students. Knowing that teachers regularly break the class into smaller groups for projects and activities, answer the following questions.
- List the advantages and disadvantages for each of the possible class sizes between 15 and 20.
  - Which size would you say is best?

**8.1 PROJECT****PRIME FACTORIZATION AND THE NUMBER OF FACTORS**

In Section 8.1, you learned about prime and composite numbers. In this project, you will explore a way to determine the number of factors a number has by using its prime factorization.

- Find the prime factorization of 18. How many times does each prime factor appear in the prime factorization? Find all possible factors of 18. How many total factors are there?
- Find the prime factorization of 100, and then find all factors of 100. How many times does each prime factor appear in the prime factorization? How many total factors are there?

2. First, find the multiples of the first 9 digits.

$$(10 \cdot 0) + (9 \cdot 3) + (8 \cdot 0) + (7 \cdot 6) + (6 \cdot 4) + (5 \cdot 0) + (4 \cdot 6) + (3 \cdot 1) + (2 \cdot 5) = 130$$

Next, add 2 for the final digit of the ISBN.  $130 + 2 = 132$

Finally, find  $132 \pmod{11}$ .

$$132 \equiv 0 \pmod{11}$$

Because the sum is congruent to  $0 \pmod{11}$ , the ISBN is valid.

## 8.2 Exercises

### ✓ CONCEPT CHECK

- The 10th digit of a 10-digit ISBN is referred to as the \_\_\_\_\_.
- True or False: If a number is a multiple of  $n$ , that number will be congruent to 0 in modulus  $n$ .
- True or False: The numbers in an ISBN are selected at random.
- True or False: The check-sum digit in an ISBN must always be equal to 0.

### 💡 PRACTICE

Determine whether each statement is true or false.

- $2^3 \equiv 3 \pmod{5}$
- $\sqrt{81} \equiv 3 \pmod{2}$
- $(3 \cdot 4) \equiv 0 \pmod{6}$
- Any two even numbers  $x$  and  $y$  are equivalent to each other mod 2; that is,  $x \equiv y \pmod{2}$ .
- Any two odd numbers  $a$  and  $b$  are equivalent to each other mod 2; that is,  $a \equiv b \pmod{2}$ .
- $645,234 \equiv 111,111,111 \pmod{3}$  (**Hint:** Two numbers are congruent mod 3 if both are divisible by 3. Use Section 8.1 methods to help you decide.)
- $9,436,278,463,920 \equiv 764,283,237,885 \pmod{5}$

Compute each value.

- $12 \equiv \underline{\hspace{1cm}} \pmod{5}$
- $13 \equiv \underline{\hspace{1cm}} \pmod{4}$
- $120 \equiv \underline{\hspace{1cm}} \pmod{11}$
- $84 \equiv \underline{\hspace{1cm}} \pmod{3}$
- $5^2 \equiv \underline{\hspace{1cm}} \pmod{2}$
- $4328 \pmod{10}$



Determine the missing digit for each 13-digit ISBN.

For a 13-digit ISBN, multiply the first digit by 1, the second digit by 3, the third digit by 1, the fourth digit by 3, and so on, until you get the 12th digit, which you multiply by 3. These products are added and the 13th digit is chosen so that the total of all these numbers is 0 modulo 10.

50. *Emma* by Jane Austin: 978048640648?

51. *Harry Potter and the Sorcerer's Stone* by J.K. Rowling: 978059035342?

52. *The Hunger Games* by Suzanne Collins: 97?0439023528

53. *The Girl with the Dragon Tattoo* by Stieg Larsson: 9?80307949486

54. *The Way of Kings* by Brandon Sanderson: 978-0765376?71

55. *Furies of Calderon* by Jim Butcher: 978-?441012688

Decide whether each barcode is valid. If it is not, state what the correct check-sum number should be.

Each of the following bar codes consists of 12 digits. To find the check-sum digit, multiply the first digit by 3, the second digit by 1, the third digit by 3, the fourth digit by 1, and so on, until you get the 11th digit, which you multiply by 3. The final digit is chosen so that the sum of the first 11 products and the final digit is 0 modulo 10.



Calculate the correct first digit for each barcode.



Credit card companies use the Luhn algorithm to help construct secure numbers. Use the following steps to determine whether each credit card number is valid. If it is not, find the correct check-sum number.

1. The check-sum digit is the last digit in the number, whether the card number is 13, 15, or 16 digits long. Working right to left, starting with the digit to the left of the check-sum number, double the value of every other digit.
2. If a number becomes a 2-digit number after doubling, treat each digit as an individual digit. Finally, sum the digits of all doubled numbers as well as the undoubled numbers including the check-sum number.
3. If the total is congruent to 0 (mod 10), then the number is valid according to the Luhn formula; otherwise it is not valid.

62. 3780 2850 1184 225

63. 300 9255 939 6891

64. 389 841 621 516 22

65. 4929 1175 0198 3180

## 8.2 PROJECT

### AFFINE SHIFT CIPHERS

In Section 8.2, you learned about modular arithmetic. In this project, you will use modular arithmetic to encode and decode messages.

One method of encoding messages is to simply convert the letters of the alphabet to numbers by identifying A with 0, B with 1, and so on.

A	B	C	D	E	F	G	H	I	J	K	L	M	N	O	P	Q	R	S	T	U	V	W	X	Y	Z
0	1	2	3	4	5	6	7	8	9	10	11	12	13	14	15	16	17	18	19	20	21	22	23	24	25

A message encoded in this manner would be a string of numbers. We can make this encryption slightly more advanced by using a shift cipher, also called a Caesar cipher, which converts the message back to a string of letters. To use a shift cipher on the numerically encoded alphabet, add a fixed value (the “shift” value) to the number and then calculate the result modulo 26, then substitute the corresponding value into the encoded string.

For example, suppose we want to encode the letter T using a shift cipher with a shift of 9. First, we need to know that T corresponds to 19. Adding the shift value results in a value of 28, which is not a number modulo 26. We can calculate that  $28 \bmod 26 = 2$ . The letter we’d use in the encoded message is C.

1. Encode the word NOTE using a shift cipher with a shift value of 11.

If the value of the shift is known, a shift cipher is easy for anyone to decode. In the example with a shift of 9, the encoded letter was C, which corresponds to a value of 2. To decode this letter, we subtract the shift value to get  $-7$ . Since this number is negative, we can add 26 to get a value between 0 and 25. In this case, we get 19, which corresponds to T.

2. Decode DLQP that was coded using a shift cipher with a shift of 11.

Since shift ciphers are relatively easy to decode, more advanced coding methods are used to keep information safe. One slightly more advanced method is an

$$\begin{aligned}
3^{4,294,967,297} - 3 &= 3^{4,294,967,296+1} - 3 \\
&= 3^{4,294,967,296} \cdot 3^1 - 3 \\
&\equiv 3,029,026,160 \cdot 3 - 3 \pmod{4,294,967,297} \\
&\equiv 9,087,078,480 - 3 \pmod{4,294,967,297} \\
&\equiv 9,087,078,477 \pmod{4,294,967,297} \\
&\equiv 497,143,883 \pmod{4,294,967,297}
\end{aligned}$$

Thankfully, this is not 0. So 4,294,967,297 is indeed not prime, but composite.

This is quite a lot of work to do by hand with a calculator, but certainly far less than the hundreds of millions of divisions we would otherwise have had to check by the divisor method. Even computers can't handle the divisor method for numbers this big, but they can use modular arithmetic to apply Fermat's Little Theorem. Now we have a healthy appreciation for what goes on behind the scenes for this computation.

### Skill Check Answers

$$\begin{aligned}
1. \quad 10^{11} - 10 &= (10 \cdot 10) \cdot (10 \cdot 10) \cdot (10 \cdot 10) \cdot (10 \cdot 10) \cdot (10 \cdot 10) \cdot 10 - 10 & 2. \quad \text{a. } 3^7 \quad \text{b. } 4^{10} \quad \text{c. } 2^6 \\
&\equiv 1 \cdot 1 \cdot 1 \cdot 1 \cdot 1 \cdot 10 - 10 \pmod{11} \\
&\equiv 1 \cdot 10 - 10 \pmod{11} \\
&\equiv 0 \pmod{11}
\end{aligned}$$

## 8.3 Exercises

### ✓ CONCEPT CHECK

- One can test for prime numbers using \_\_\_\_\_.
- True or False: If a statement is true, then the contrapositive is also true.
- True or False: If you calculate a 0 from the contrapositive of Fermat's Little Theorem, then the power must be a prime number.

### 💡 PRACTICE

Verify that Fermat's Little Theorem holds true for each prime number using the value of  $x$  given.

- The prime number 11 and  $x = 6$
- $x = 2$  with the prime 23
- The third prime number and  $x = 10$
- $p = 79$  and  $x = 3$
- The prime number 13 and  $x = 3$
- The prime number 17 and  $x = 2$

10.  $x = 3$  with the prime 19

11.  $p = 31$  and  $x = 4$

12.  $p = 7$  and  $x = 2$

Use the contrapositive of Fermat's Little Theorem to show that each given number is composite.

13. 63,571 using  $x = 3$

14. 12,731 using  $x = 3$

15. 65,476,751 using  $x = 2$

17. 7802 using  $x = 2$

18. 10,431 using  $x = 3$

19. 103,322 using  $x = 3$

20. 123,456,782 using  $x = 2$

Use technology to confirm that each given number is composite using the contrapositive of Fermat's Little Theorem.

21. 2427

22. 24,271

23. 245,127

24. 10,050,207

25. 1963

26. 1649

27. 903,219

28. 10,203

29. 565,841

30. 106,057

31. 35,066

32. 14,772,361

## 8.3 PROJECT

### FERMAT AND MERSENNE PRIMES

In Section 8.3, you learned about Fermat's Little Theorem and testing whether numbers are prime. In this project, you will explore two special types of numbers and test whether they are prime.

Very large prime numbers play a vital role in keeping information secure. There are two special types of numbers that have played a role in searching for large primes. They are called Fermat numbers and Mersenne numbers. A Fermat number is a number of the form  $2^{2^n} + 1$ , where  $n = 0, 1, 2, \dots$ . For example, when  $n = 2$ , we have the Fermat number  $2^{2^2} + 1 = 2^4 + 1 = 17$ . Since this resulting number is prime, we say that 17 is a Fermat prime.

1. Find the Fermat numbers that correspond to  $n = 0$ ,  $n = 1$ , and  $n = 3$ . Are these numbers Fermat primes? (Note that the Fermat number 65,537, which corresponds to  $n = 4$ , is a Fermat prime.)
2. Find the Fermat number that corresponds to  $n = 5$ .
3. Evaluate the expression  $(2^9 + 2^7 + 1)(2^{23} - 2^{21} + 2^{19} - 2^{17} + 2^{14} - 2^9 - 2^7 + 1)$ . Is the Fermat number that corresponds to  $n = 5$  a prime number? Why or why not?

## 8.4 Exercises

### ✓ CONCEPT CHECK

1. In Euler's Theorem, the variables  $p$  and  $q$  are \_\_\_\_\_ numbers.
2. Public-key encryption relies on \_\_\_\_\_ numbers.
3. True or False: It was said that Julius Caesar communicated with his army using the Julius cipher.

### 💡 PRACTICE

Verify Euler's Theorem for each given number.

4.  $n = 77, p = 7, q = 11, x = 2$ , and  $a = 1$
5.  $n = 91, p = 13, q = 7, x = 3$ , and  $a = 2$
6.  $n = 155, p = 31, q = 5, x = 4$ , and  $a = 6$

Encode each number using the given public key.

7. Encode the number  $M = 14$  using the public key  $n = 77$  and  $e = 13$ .
8. Encode the number  $T = 49$  using the public key  $n = 77$  and  $e = 37$ .
9. Encode the number  $CC = 101$  using the public key  $n = 119$  and  $e = 11$ .
10. Encode the number  $K = 55$  using the public key  $n = 119$  and  $e = 35$ .
11. Encode the number  $M = 3$  using the public key  $n = 105$  and  $e = 10$ .
12. Encode the number  $A = 8$  using the public key  $n = 91$  and  $e = 4$ .
13. Encode the number  $BB = 21$  using the public key  $n = 15$  and  $e = 2$ .
14. Encode the number  $J = 100$  using the public key  $n = 63$  and  $e = 8$ .

Decode each number using the given private key.

15. Decode the number  $PR = 15$  using the private key  $d = 53$  and  $n = 77$ .
16. Decode the number  $TD = 38$  using the private key  $d = 17$  and  $n = 77$ .
17. Decode the number  $C = 64$  using the private key  $d = 35$  and  $n = 221$ .
18. Decode the number  $W = 219$  using the private key  $d = 151$  and  $n = 781$ .
19. Decode the number  $AC = 12$  using the private key  $d = 7$  and  $n = 77$ .

20. Decode the number  $B = 35$  using the private key  $d = 3$  And  $n = 99$ .
21. Decode the number  $RJ = 21$  using the private key  $d = 31$  And  $n = 65$ .
22. Decode the number  $M = 72$  using the private key  $d = 11$  And  $n = 57$ .

Use technology to break each code.

23. Suppose  $p = 23$  and  $q = 71$ . Calculate what  $d$  must be if  $e = 51$  and  $a = 5$ .
24. Suppose  $p = 17$  and  $q = 61$ . Calculate what  $d$  must be if  $e = 71$  and  $a = 23$ .
25. Suppose  $n = 187$  and  $e = 19$ . Calculate what  $d$  must be as well as the two primes  $p$  and  $q$ , if  $a = 7$ .
26. Suppose  $n = 589$  and  $e = 23$ . Calculate what  $d$  must be as well as the two primes  $p$  and  $q$ , if  $a = 2$ .

Trapezoid	Length of Left-Hand Side (in inches)	Length of Right-Hand Side (in inches)	Area of Trapezoid (in square inches)
$T_3$	$f(3) = (3)^2 = 9$	$f(4) = (4)^2 = 16$	$A_3 = \frac{1}{2}(9+16)(1) = \frac{25}{2}$
$T_4$	$f(4) = (4)^2 = 16$	$f(5) = (5)^2 = 25$	$A_4 = \frac{1}{2}(16+25)(1) = \frac{41}{2}$

The Total Area of the Four Trapezoids:

$$\frac{5 \text{ in.}^2}{2} + \frac{13 \text{ in.}^2}{2} + \frac{25 \text{ in.}^2}{2} + \frac{41 \text{ in.}^2}{2} = \frac{84 \text{ in.}^2}{2} = 42 \text{ in.}^2$$

Thus, the approximate area under the curve is 42 square inches.

If we divided the area under the curve in the previous example into more and more trapezoids, we would get a better and better approximation for the area. This is exactly the foundation for integral calculus, but the details will have to wait for another math course on another day.

#### Skill Check Answers

1. 7 ft × 12 ft and 9 ft × 40 ft    2. Area = 78.5 in.<sup>2</sup>; Circumference = 31.4 in.

## 9.1 Exercises

### ✓ CONCEPT CHECK

- The perimeter of a circle is called its \_\_\_\_\_.
- A trapezoid is a quadrilateral that has exactly one pair of \_\_\_\_\_ sides.
- A \_\_\_\_\_ is a pattern made of one or more geometric shapes so that there are no gaps or overlaps.
- True or False: The formulas for the perimeter and area of a rectangle can be used to find the perimeter and area of a square.

### 🔑 APPLICATIONS

Round your answer to the nearest tenth, if necessary.

- A rectangular pane of antique glass has dimensions of 25 inches by 48 inches. If glass sells for \$0.50 per square inch, how much will each window cost?
- Carpet Pro sells carpet for \$1.50 per square foot. If you wish to carpet a room that measures 16 feet by 25 feet, how much will the carpet cost?

7. A 25-lb bag of grass seed will cover 1200 square feet. If your lawn is in the shape of a rectangle and measures 205 feet by 145 feet, how many bags of grass seed will you need to cover the lawn?
8. Devon wants to paint an accent wall in his condo. The wall measures 12 feet long and 8 feet high. If a quart of paint covers 100 square feet, will one quart be enough to paint the wall?

Find the area of the shaded region in each figure. Round your answer to the nearest hundredth, if necessary.

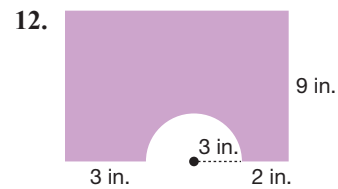
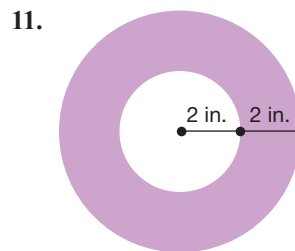
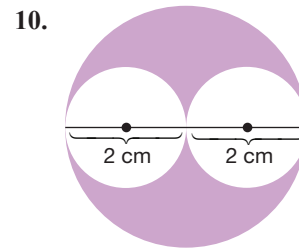
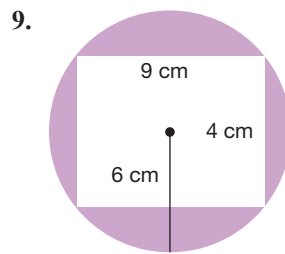

13. A swimming pool is in the shape of the following figure. The homeowner wishes to create a canvas cover for the pool. How many square feet of canvas would be required to make a cover for the pool?
14. A homeowner wants to create a canvas cover for the pool that is the shape of the following figure. How many square feet of canvas would be needed to cover the pool?
15. Gilbert is making a glass art project that requires two squares and two right triangles as shown. If the glass cost \$0.24 per square inch, how much will the glass for the project cost?

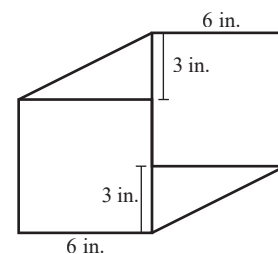
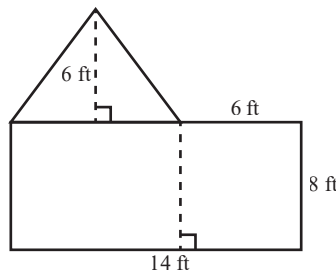

16. Shira needs to buy new siding for one end of her house, which is shown in the following figure. How many square meters of siding will she need?

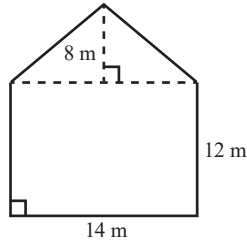

17. Micah is tiling his bathroom with parallelogram-shaped tiles as shown in the following figure. If the bathroom is 8 feet by 9 feet, how many boxes of tiles will he need if each box contains 26 tiles?

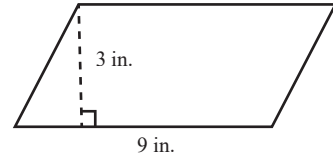

18. Each campsite at Lake Montgomery is in the shape of a parallelogram, as shown in the figure below, and there are 22 camp sites. Every spring, the department of recreation covers all 22 sites with pine straw. If one bail of pine straw will cover about 45 square feet, how many bails of pine straw will it take to cover all 22 sites?

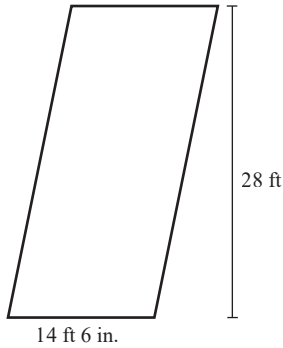

19. Jackson is making a flower bed that will have a triangular portion in the middle and two parallelogram-shaped portions on either side, as shown in the figure. The parallelograms will be filled with shrubs, and each requires a minimum of 4 square feet. The triangle will be filled with flowers and each flower will need a minimum of 0.25 square feet. How many shrubs and how many flowers can Jackson put in the flower bed?

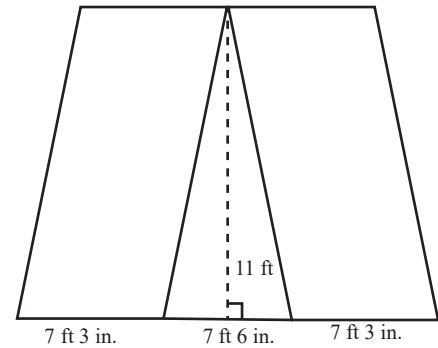

20. The Internal Revenue Service allows qualifying taxpayers to claim a home office on their taxes for any area of their home that they use for business purposes. Taxpayers are allowed to claim \$5 per square foot for business use, with a maximum of 300 square feet. The Hills meet the requirements to deduct their home office space on their taxes. Calculate the amount they are allowed to deduct based on their home measurements.

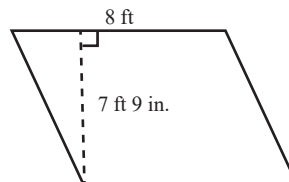

21. Members of a robotics club are tasked with moving their robot from point A to point B. The robot understands the following commands.

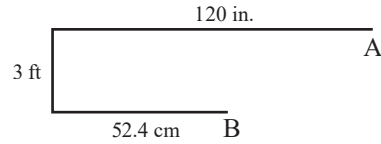

- Rotate wheels forward  $x$  number of rotations.
- Rotate wheels backward  $x$  number of rotations.
- Turn  $90^\circ$  left.
- Turn  $90^\circ$  right.

If the wheels of the robot have a 3-inch radius, determine the sequence of commands that the robot should be given.

22. Members of a robotics club are tasked with moving their robot from point A to point B. The robot understands the following commands.

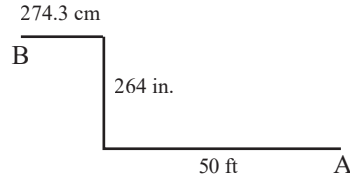

- Rotate wheels forward  $x$  number of rotations.
- Rotate wheels backward  $x$  number of rotations.
- Turn  $90^\circ$  left.
- Turn  $90^\circ$  right.

If the wheels of the robot have a diameter of 12 cm, determine the sequence of commands that the robot should be given.

23. Farah rode her bike from point A to point B. If it took her bike’s wheels exactly 8 rotations, and if the distance between the two points is 54.5 feet, what is the radius of Farah’s tires in inches?

24. In hockey, “the trapezoid” is the trapezoidal area behind the goal, as shown in the following figure, where the goalie is legally allowed to play the puck. What is the area of the trapezoid?

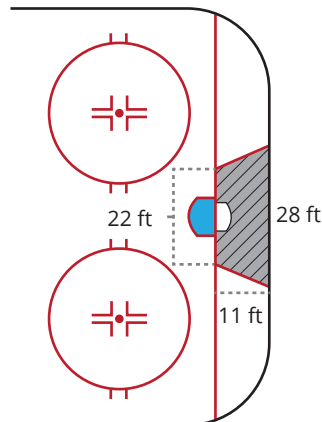

25. Bart built a workshop in the shape of a trapezoid as shown. Find the cost of the siding needed for the front of the shop if the siding cost \$2.65 per square foot. The garage door should not be included.

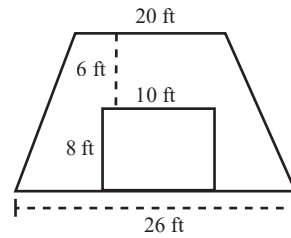

26. Luis is making trapezoidal tables for the preschool at his church. He plans to make 6 of them and will cover each table with laminate. If the laminate cost \$23 per square foot, how much will the laminate for the 6 tables cost?

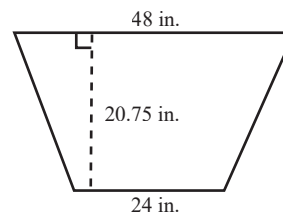

27. The trapezoidal window shown got broken during a storm. Find the cost if the replacement glass costs \$12.97 per square foot.

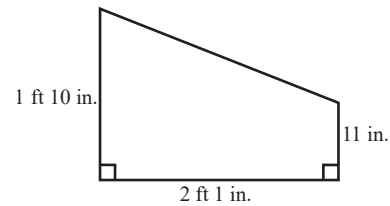

28. Find the perimeter and area of the floor tile represented by the parallelogram.

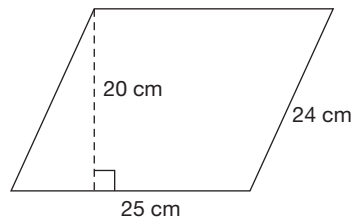

29. The side view of a wheel for a skate is shown. What is the circumference of the wheel? How many square inches of paint are required to paint the wheel?

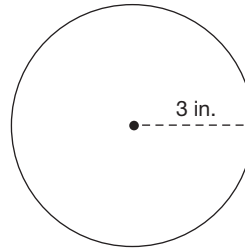

30. A piece of cake has the shape of the following figure. What is the area of the top of the cake slice?

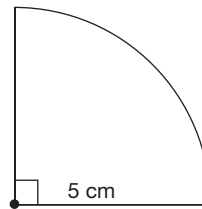

31. A window in the shape of the following figure is needed for a new home. If glass costs \$0.85 per square foot, how much will the window cost?

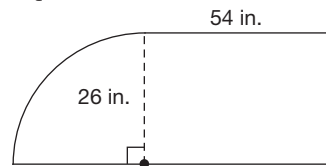

32. A rectangular piece of land has dimensions 1200 ft by 850 ft. Find the amount of fencing needed to construct a fence around the perimeter of this piece of land. Also find the area of the land to be enclosed.
33. A hot tub will have the footprint of a regular polygon, shown in the following figure. If your builder wishes to cover the area under the hot tub with plastic, how many square meters of plastic are needed?

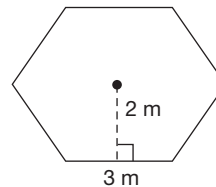

34. The graph of the function  $y = \frac{1}{4}x^2$  is shown, where  $x$  and  $y$  are both measured in centimeters. Approximate the area under the curve between  $x = 2$  and  $x = 4$ .

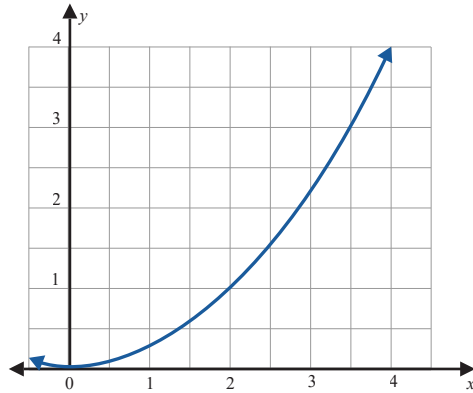

35. The graph of the function  $y = 2\sqrt{x}$  is shown, where  $x$  and  $y$  are both measured in inches. Approximate the area under the curve between  $x = 1$  and  $x = 4$ .

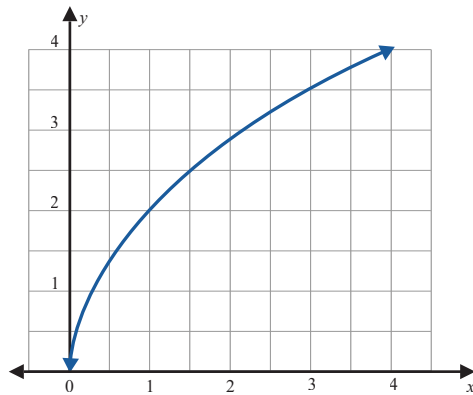

36. The graph of the function  $y = \sqrt{-x}$  is shown, where  $x$  and  $y$  are both measured in centimeters. Approximate the area under the curve between  $x = -1$  and  $x = -4$ .

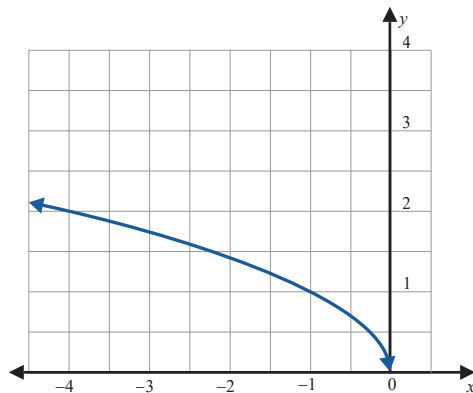

37. The graph of the function  $y = x$  is shown, where  $x$  and  $y$  are both measured in meters. Find the area under the curve between  $x = 1$  and  $x = 3$ .

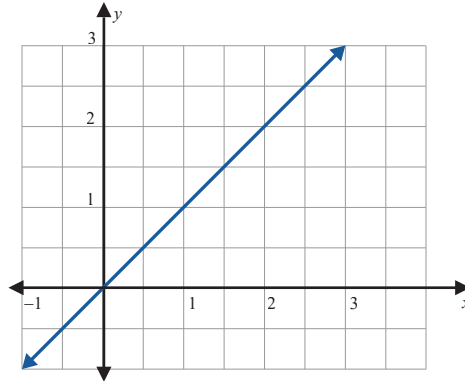

## 9.1 PROJECT

### TETRIS-ROBOTICS

Have you ever played the game Tetris? Tetris is a tile-matching video game that was created by Alexey Pajitnov in 1984. The game has seven different pieces, called tetriminos.

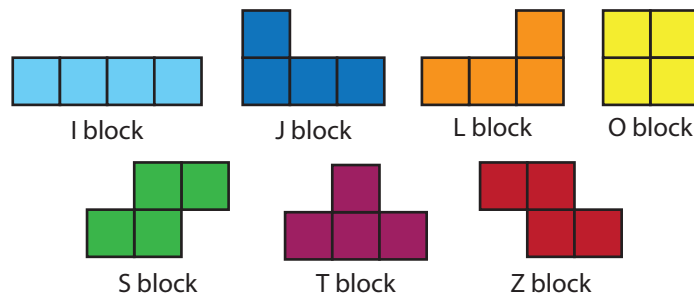

Suppose a science club is programming a robot to play a modified game of Tetris. In their game, each square that makes up a tetrimino has a side of 10 inches. For example, the O block, which is 2 squares wide by 2 squares tall, would be 20 inches wide and 20 inches tall while the dimensions of the I block would be 40 inches wide by 10 inches tall. The corresponding playfield is 10 squares wide by 16 squares tall. In this project, you will create a sequence of commands for a robot to navigate a specific path to place a tetrimino in the playfield.

The robot's wheels are 3 inches in diameter, and the robot understands the following commands:

- Rotate wheels forward  $n$  rotations, where  $n$  is a positive real number.
- Rotate wheels backward  $n$  rotations, where  $n$  is a positive real number.
- Turn  $90^\circ$  left.
- Turn  $90^\circ$  right.

## 9.2 Exercises

### ✓ CONCEPT CHECK

1. Volume is measured in \_\_\_\_\_ dimensions while surface area is measured in \_\_\_\_\_ dimensions.
2. All points on the surface of a sphere are the same distance from a \_\_\_\_\_ point.
3. A square pyramid has four \_\_\_\_\_ sides.
4. True or False: A cube is a type of rectangular solid.
5. True or False: A cylinder can have ends that are different sizes and shapes.

### 💡 PRACTICE

In each of the following scenarios, consider the space being described and determine whether you should calculate the volume or surface area.

6. The amount of coffee in a can
7. How much shaved ice is needed for a snow cone
8. How many gallons of paint needed for the siding on your house
9. The amount of sand in a sandbox
10. How much cedar is needed to line a hope chest
11. The amount of leather needed to cover a basketball

### 👤 APPLICATIONS

12. If the volume of a right circular cone is  $360 \text{ ft}^3$ , find the volume of a right circular cylinder with the same radius and height.
13. If the volume of a right circular cylinder is  $360 \text{ ft}^3$ , find the volume of a right circular cone with the same radius and height.
14. You want to make a fish tank in the shape of a rectangular solid that can hold 26,250 cubic centimeters of water. If the length is to be 50 cm and the height is to be 35 cm, then how wide is the tank? How many square centimeters of glass are needed to construct the tank?

15. The concrete foundation of a house requires 15 truckloads of concrete. The concrete was poured at a depth of 0.5 meters and covered an area of 540 square meters.
- How many cubic meters of concrete were used?
  - If each truckload was the same size, how many cubic meters did each truck carry?
16. The surface of a house is covered with vinyl siding. The gable end (triangular portion) of the house and the roof will not need siding. Determine the amount of siding required.

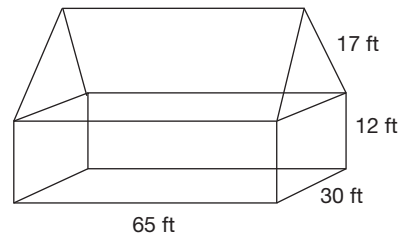

17. Montgomery has a box that is 24 inches by 36 inches by 12 inches and is filled with sand. He wants to use this sand to fill as many 4-inch cubes as he can. How many cubes can he fill?
18. A company is shipping a piece of equipment that requires a cubic box with a volume of 216 cubic feet. How many square feet of wood are required to construct the box?
19. Isaac made a rectangular shaped raised flower bed that is 12-feet long, 4-feet wide and 1.5-feet high. He wants to line the inside of the bed with landscape fabric. How many square feet of fabric will he need?
20. Emeril baked a sheet cookie that is 15 inches by 24 inches. If he wants to serve one piece to each of his 40 guests, what size squares should he cut?
21. A company needs cubic boxes that will hold 729 cubic inches. How many square inches of cardboard will be required to construct each box?
22. The Earth has a diameter of about 7900 miles.
- What is the approximate surface area of the Earth?
  - What is the approximate volume of the Earth?
  - If  $\frac{2}{3}$  of the Earth's surface is covered with water, about how many square miles of the surface are covered by land?
23. The moon has a diameter of approximately 2160 miles.
- What is the approximate surface area of the moon?
  - If one-third of the moon is covered in craters, about how many square miles of the moon's surface is crater free?

24. Lisa makes Christmas ornaments from Styrofoam balls with a 3-inch diameter.
- Calculate the surface area of one of the balls rounded to the nearest hundredth.
  - What is the maximum number of balls Lisa can make from 1 square yard of fabric?
25. Patti is making 2 papier-mâché balls for a party. To make the balls, she will cover balloons that have a 12-inch diameter with the papier-mâché material.
- Calculate the surface area of one balloon rounded to the nearest hundredth.
  - If each balloon must be covered five times to create a sturdy ball, how many pieces of 8.5 by 11 inch paper will be needed to cover the two balloons?
26. Helen is filling round balloons with helium for a wedding. Each balloon has a diameter of 12 inches. Her helium tank contains 14.9 cubic feet of helium.
- How many cubic feet of helium does one balloon hold when filled to a diameter of 12 inches?
  - How many balloons can she fill with the amount of helium in the tank?
  - If Helen wants to use more balloons in the decorations but doesn't want to purchase more helium, she can fill each balloon to an 11-inch diameter instead of 12. How many balloons can she fill now?
  - By what percentage does the volume decrease when the diameter decreases from 12 inches to 11 inches?
27. A grain silo in the shape of a circular cylinder is 75 feet tall and has a diameter of 24 feet.
- What is the volume of the silo?
  - If a bushel of grain is 1.25 cubic feet, then how many bushels of grain will the silo hold?
  - If a truck can unload 200 cubic feet of grain per minute into the silo, how long will it take to fill the entire silo?
28. The town of Batesburg has a cylindrical water tower that has a height of 15 meters and a diameter of 8 meters.
- Find the volume of the water tower.
  - If 1 cubic meter is equal to 264.172 gallons, how many gallons of water will the water tower hold?
  - Suppose the water tower holds about a day's worth of water for the community when filled to full capacity. Approximately how many households are in Batesburg if the average household uses 400 gallons of water per day?

29. Maxine has two cylindrical vases. Vase A has a radius of 2.5 cm and a height of 25 cm, and vase B has a radius of 4 cm and a height of 10 cm.
- Find the volume of each vase.
  - Which vase has a larger volume? What is the difference in volume between the two vases?
30. The manager of the Blizzard Snow Cone truck ordered a new style of paper cones. These new cones have a height of 12 cm and a radius of 8 cm. The dome of ice that goes on top of the cone will remain the same size, and the dome is made of  $1072 \text{ cm}^3$  of ice.
- Find the volume of the cone rounded to the nearest hundredth. (**Hint:** Do not include the volume of the dome.)
  - The shaved ice is kept in a cooler that is 80 cm by 40 cm by 70 cm. How many snow cones can be made? (**Hint:** Do not forget to include the dome.)
31. A shaved ice stand bought a new ice shaving machine and received a new inventory of paper cones.
- Find the volume of a cone if the paper cup has a diameter of 9 cm and a height of 8 cm.
  - The new ice shaving machine can shave about  $50 \text{ cm}^3$  per minute. About how many minutes will it take to shave enough ice to fill 12 snow cones if the domes of ice that go on top take an additional  $190 \text{ cm}^3$ .
32. A reception will be held in the lobby of a building that has an inverted square pyramid fountain with a height of 150 inches and side-length of 120 inches. Lani is making table decorations for the reception by filling small replicas of the fountain with glass beads.
- Find the volume of the small vases if they are in a 1 : 20 ratio with the fountain.
  - If each bag of beads contains 30 cubic inches of beads and there are 8 replicas, how many bags of beads will Lani need?
33. Bo built a sandcastle in the shape of a square pyramid. The side length of the pyramid was 8 feet and the height was 4 feet.
- How many cubic feet of sand did it take to build the castle?
  - If Bo decides to build a small replica that has a ratio of 1 : 3, how much sand would be needed for the replica?
34. Selene's teacher made a square pyramid and gave the class an assignment to make replica pyramids out of clay with a ratio of 1 : 6. If the side length of the pyramid made by the teacher is 24 inches and the height is 30 inches, find the volume of the replica that Selene needs to make.
35. The Great Pyramid of Giza is the largest structure ever built by man. It is a square pyramid with a side length of approximately 230.36 meters and a height of approximately 146.59 meters. A gift shop sells replicas that has a ratio of 1 : 200. Determine the volume of the replica.

36. Which swimming pool holds more water?

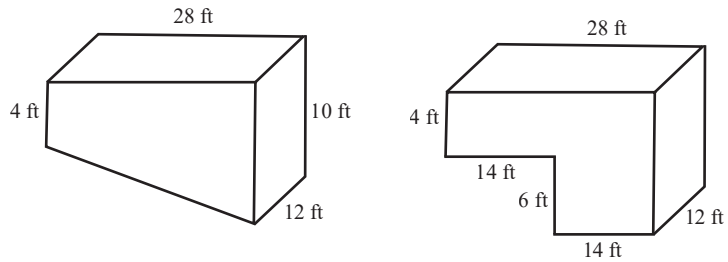

37. Michaela is making a cylindrical candle. She has 2 blocks of candle wax that will melt to give her a total of  $400 \text{ cm}^3$  of wax. She doesn't want the candle to be more than 20 cm tall. Find a set of dimensions that will meet the restrictions and will also use all of the candle wax.
38. Delilah is making a cylindrical candle. She has 3 blocks of candle wax that will melt to give her a total of  $80 \text{ in.}^3$  of wax. She doesn't want the radius of the candle to be smaller than 1 inch. Find a set of dimensions that will meet the restrictions and will also use all of the candle wax.
39. David is building a cylindrical rainwater harvesting storage tank in his backyard, and he wants it to hold 1000 gallons or about 134 cubic feet of water. His HOA will not allow any free-standing structures taller than 8 feet. Find a set of dimensions that will meet these restrictions.
40. Phillipe wishes to have a grain silo in the shape of a right circular cylinder that can store 200,000 cubic feet of grain. If he doesn't want the silo to be any taller than 50 feet, determine a set of dimensions that will meet his needs.
41. Refer to Example 9.2.12 of the section to solve the following problems.
- Find the surface area of the record-breaking cup, given that the surface area of a frustum can be calculated using the formula  $SA = \pi(R_1 + R_2)\sqrt{(R_1 - R_2)^2 + h^2} + \pi R_2^2 + \pi R_1^2$ .
  - Paper is not a viable option for the cup because it is not strong enough, so the owner has opted to use steel. If steel costs \$7.25 per square meter, what is the cost of material to make the world record cup?

## 9.3 Exercises

### ✓ CONCEPT CHECK

- Two angles are supplementary angles if the sum of their measures equals \_\_\_\_\_ degrees.
- Two angles are vertical angles if they are the \_\_\_\_\_ angles formed when two lines intersect.
- The three basic trigonometric functions are \_\_\_\_\_, \_\_\_\_\_, and \_\_\_\_\_.
- True or False: The Pythagorean Theorem can be used for any type of triangle.
- True or False: The Law of Sines and Law of Cosines can be used interchangeably.

### 💡 PRACTICE

Determine whether each angle is acute, right, or obtuse.

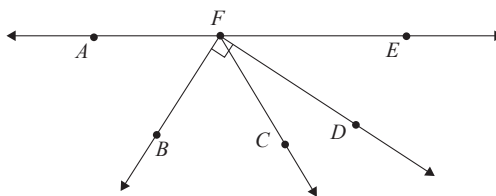

- |                 |                  |                  |
|-----------------|------------------|------------------|
| 6. $\angle BFD$ | 7. $\angle DFE$  | 8. $\angle AFD$  |
| 9. $\angle AFB$ | 10. $\angle EFC$ | 11. $\angle EFB$ |

In the figure,  $\overline{YU}$  bisects (divides into 2 equal parts)  $\angle WYV$  and  $\overline{YT}$  bisects  $\angle XYV$ . Use the figure to answer each question.

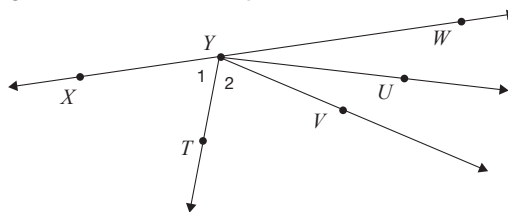

- If  $m\angle WYV = 36^\circ$ , find  $m\angle WYU$ .
- If  $m\angle 1 = 56^\circ$ , find  $m\angle 2$ .
- If  $m\angle VYW = 82^\circ$  and  $m\angle WYU = (4r + 25)^\circ$ , find  $r$ .
- If  $\angle XYV$  has a measure of  $162^\circ$ , find  $m\angle 1$ .

Use the figure to answer each question.

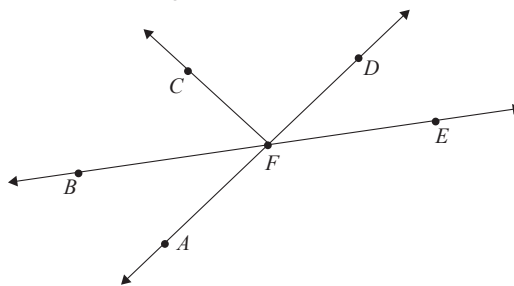

16. If  $m\angle CFD = (15a + 45)^\circ$ , find  $a$  so that  $\overrightarrow{FC} \perp \overrightarrow{FD}$ .
17. If  $m\angle AFB = (8x - 6)^\circ$  and  $m\angle BFC = (14x + 8)^\circ$ , find the value of  $x$  so that  $\angle AFC$  is a right angle.
18. If  $m\angle BFA = (3r + 12)^\circ$  and  $m\angle DFE = (-8r + 210)^\circ$ , find  $m\angle AFE$ . (**Hint:** Recall that lines that intersect at a common point share vertical angles that are congruent.)

In the following figure, lines  $a$  and  $b$  are parallel.

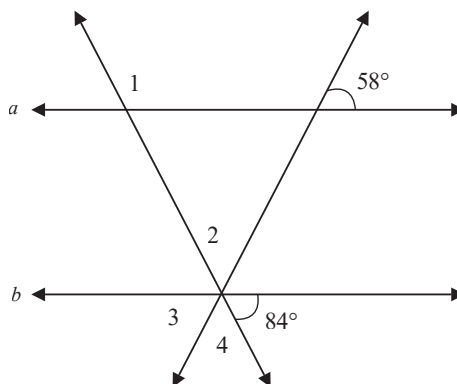

19. Find  $m\angle 1$ .
20. Find  $m\angle 2$ .
21. Find  $m\angle 3$ .
22. Find  $m\angle 4$ .
23. The measures of two complementary angles are  $(16z - 1)^\circ$  and  $(12z + 7)^\circ$ . Find the measures of the angles.
24. Find  $m\angle T$  if  $m\angle T$  is 20 more than four times its supplement.
25. Two angles are supplementary. One angle is  $12^\circ$  more than the other. Find the measures of the angles.
26. A regular dodecagon has 12 interior angles, each measuring  $150^\circ$ . Can a tessellation be created using only regular dodecagons?
27. A regular nonagon has 9 interior angles, each measuring  $140^\circ$ . Can a tessellation be created using only regular nonagons?

28. Use  $\triangle ABC$  to find  $\sin A$ ,  $\cos A$ ,  $\tan A$ ,  $\sin B$ ,  $\cos B$ , and  $\tan B$ . Round your answers to the nearest hundredth.

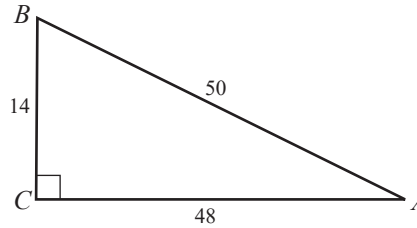

29. Use  $\triangle ABC$  to find  $\sin A$ ,  $\cos A$ ,  $\tan A$ ,  $\sin B$ ,  $\cos B$ , and  $\tan B$ . Round your answers to the nearest hundredth.

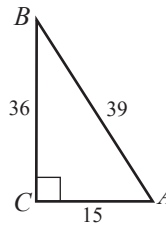

Decide whether to use the Law of Sines or the Law of Cosines to solve for the unknown value  $x$  in each scenario.

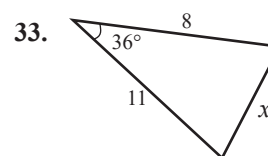
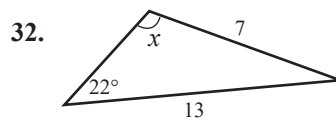
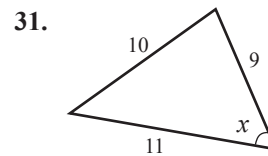
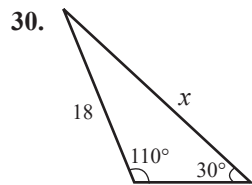

APPLICATIONS

34. The shortest path from A to B is across Lazy Lake, shown below. How far is this path?



35. Find the value of  $x$  in the following diagram of a truss bridge.

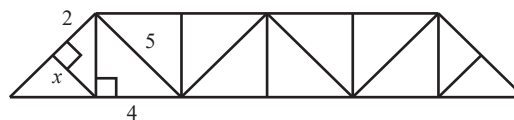

36. Jonathan is building a cabinet in his workshop and will be installing it in his den which has 7-foot-high ceilings.
- If the cabinet is 6-feet tall, what is the deepest that he can make the cabinet and clear the ceiling when it is stood upright?
  - Determine a general formula that Jonathan can use when building cabinets so that he can always know the maximum depth of any cabinet given the height of the ceiling and the height of the cabinet.
37. Anastasia is designing a cabinet for a client whose living room has 9-foot ceilings. The client wants the cabinet to be as tall as possible. Anastasia will create the cabinet in her workshop and transport it to the client's home.
- If the depth of the cabinet is 18 inches, what is the tallest Anastasia can make the cabinet and clear the ceiling when it is stood upright?
  - Determine a general formula that Anastasia can use when designing cabinets so that she can always know the maximum height of any cabinet given the height of the ceiling and the depth of the cabinet.
38. Bartholomew is designing a bookcase for the town library. The ceilings are 12-feet high.
- If he wants the bookcase to be as tall as possible, and if the depth of the bookcase must be 16 inches, what is the maximum height that he can make the bookcase and it still be able to clear the ceiling when stood upright?
  - Determine a general formula that he can use when designing cabinets so that he can always know the maximum height of any cabinet given the height of the ceiling and the depth of the cabinet.
39. Calvin is laying out a garden based on an architectural plan. He has marked the location of the first two corners, points A and B, which are 60 feet apart. The next corner will be 30 feet from point B at an angle of  $50^\circ$ . Using only a surveyor's rope and string, he needs to mark the  $50^\circ$  angle at point B. Determine how he can create this angle using a right triangle.

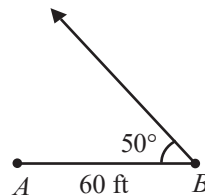

40. A drone is flying 2 meters directly above a flagpole that is located 6 meters from a building. If the angle of depression from the drone to the base of a building is  $64^\circ$ , find the height of the flagpole.

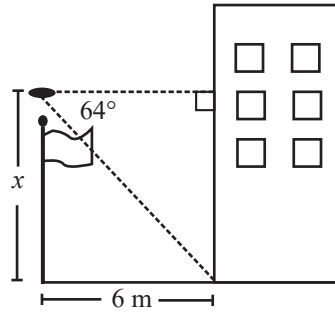

41. The sun hits a building of unknown height so that the building casts a shadow of 517 feet. If the angle of elevation from the tip of the shadow to the sun is  $16^\circ$ , how tall is the building?
42. A snow ski slope has a run of 1.5 miles with an angle of elevation of  $24^\circ$ . What is the length of the vertical drop of the ski slope?
43. A wheelchair ramp is to be constructed with a maximum incline of  $6^\circ$ . If the height of the ramp is to be 5 feet, how long should the ramp be after construction?
44. A section of highway has an incline of  $10^\circ$ . If the length of the incline is 5 miles, what is the horizontal distance of the incline?
45. A 16 ft ladder is leaning against a wall where it makes an angle of  $68^\circ$  with the ground and  $22^\circ$  with the building.
- How far is the ladder base from the building?
  - How far does the ladder reach up the building?
46. Leo is flying his drone from his apartment balcony to watch the entrance for his friend's arrival. The drone is currently flying 2 meters directly above a 10-meter tall flagpole, which is located 6 meters from the entrance of the building. Find the angle of depression that the camera on the drone would need to use to focus on the base of the door of the building. Round your answer to the nearest tenth.

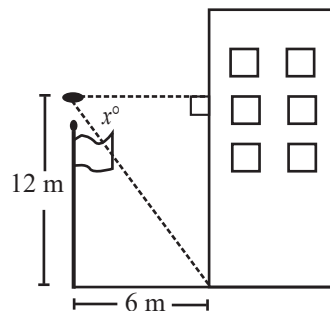

47. A plane is flying at an altitude of 2000 feet. It is on course maintain altitude and pass directly over a 150-foot tower. Determine the current angle of depression to the top of a 150-foot tower if the tower is 1000 feet away. Round your answer to the nearest tenth.

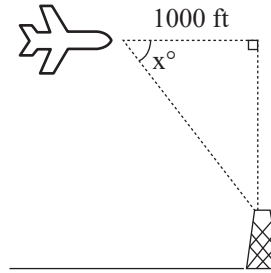

48. Selena spots a balloon that is 16 feet in the air. If she is 5-feet tall and the distance from the top of her head to the balloon is 15 feet, what is the angle of elevation from the top of her head to the balloon? Round your answer to the nearest tenth.

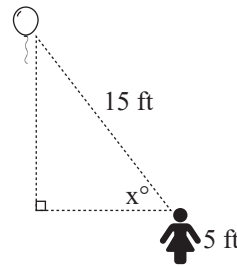

49. Two buildings are located 50 feet apart. One building is 100-feet tall and the other is 60-feet tall. A camera is placed the top edge of the shorter building to watch a bird nest located at the top edge of the taller building. What angle of elevation is needed to focus the camera from the top of the shorter building to the top of the taller building? Round your answer to the nearest tenth.

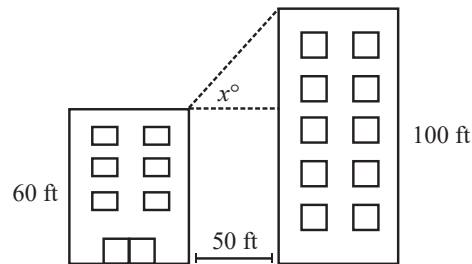

50. A weather balloon is spotted by two people who are 20 meters apart. The angle of elevation from the first person is  $56^\circ$  and the angle of elevation from the second person is  $40^\circ$ . Calculate the altitude of the balloon when it was spotted. Round your answer to the nearest tenth.

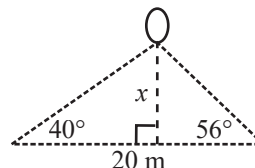

51. A person is standing 16 feet from the base of a building and looking at the top of a flagpole that is on top of the building. The flagpole is 10-feet tall. The angle of elevation from where the person is standing to the top of the flagpole is  $75^\circ$ . Determine the height of the building, rounded to the nearest tenth.

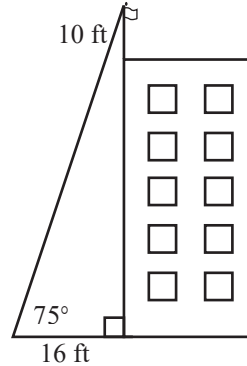

52. Patricia is currently located on a dock on an island. She wants to determine the route that would be fastest to travel from the island to dock B on the mainland. She has the options of rowing her boat to dock A and then riding a bike to dock B or of rowing her boat directly to dock B. She knows that the distance from the island dock to dock A is 1.2 miles and the distance from the island dock to dock B is 1.8 miles. The angle between docks A and B is 68 degrees. Patricia needs to determine the distance from dock A to dock B to help her determine which would be faster. How far is dock B from dock A?

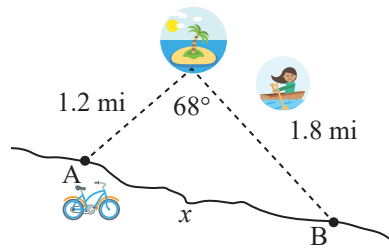

53. If you are standing at a certain spot on Lookout Mountain in Tennessee, you can see seven states. Of these seven, you can see Alabama, which is 25 miles away, and South Carolina, which is 80 miles away. The angle between these two states from your location is approximately  $70^\circ$ . Determine the distance between these two sites, rounded to the nearest mile.



 WRITING & THINKING

54. Can you tessellate the plane with the following figure? Explain your answer.

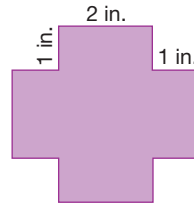

55. Use the given figure to create a tessellation by rotating, reflecting, or translating. Describe which transformations you used to create the tessellation.

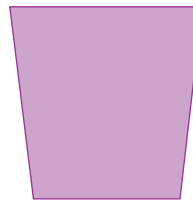

## 9.3 PROJECT

## MAN CAVES AND SHE SHEDS

The company *Tiny House Livings* is gearing up for their annual Man Cave and She Shed Competition. Every year the competition focuses on different features; this year's focus is the roof. The main contest restrictions this year are that you cannot measure anything directly with a tape measure, you must use your height and the length of your hand to “measure,” and then you must provide the pitch angle and rafter length.

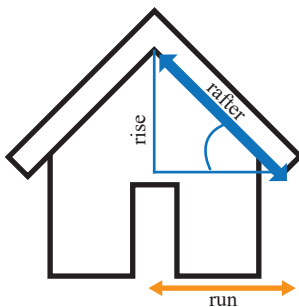

Suppose that you have always dreamed of owning one but haven't had a chance to save up the money to buy one nor the tools and materials to build one. Thanks to the competition, you now have the chance to win one! Use your own hand length as the standard unit of measurement.

1. Refer to the sketch provided of a man cave or she shed. First, estimate your height in hands and then estimate that the end of the roof overhang is 4 hands above your head. How high is the end of the roof overhang from the ground?
2. You use the length of your hand to measure the run of one side of the shed roof, which is half the width of the shed. You discover the run is twenty “hands” long. What is the length of the run in inches?
3. You estimate the rise to be 8 “hands” high. What is the pitch angle of the roof?  
**Hint:** Pay attention to your units!
4. What is the length of the rafter?
5. What influences the accuracy of your calculations? What can you do to make the estimations more precise?

# 10.1 Exercises

## ✓ CONCEPT CHECK

1. A probability experiment, or a \_\_\_\_\_, is any process with a result determined by chance.
2. The \_\_\_\_\_ is the set of all possible outcomes for a given probability experiment.
3. Each path of branches in a \_\_\_\_\_ indicates a single possible outcome.
4. The Law of Large Numbers says that the greater the number of trials, the closer the \_\_\_\_\_ probability will be to the \_\_\_\_\_ probability.
5. True or False: The probability of something occurring can never be 1.

## 💡 PRACTICE

Create a tree diagram to list the outcomes in each sample space.

6. Find the sample space for the gender of each child in regard to birth order for a family with three children.
7. In picking out a new car, there are several choices to make. The color can be red, white, or silver. The seats can be cloth or leather. Finally, it can have a sunroof, a moonroof, or neither. Find the sample space for the possible new car combinations using a tree diagram.
8. Use a tree diagram to find the sample space for tossing a coin three times.
9. Four students are randomly selected from an algebra class and asked whether they suffer from math anxiety. Find the sample space for the possible outcomes of the survey using a tree diagram.

Identify the sample space for each of the following experiments.

10. A coin is flipped and then a single die is rolled.
11. Choosing a number from all positive two-digit integers where the digits are repeated (for example, 11).
12. Five marbles are in a bag, one of each of the following colors: blue (B), clear (C), green (G), yellow (Y), and red (R). Two marbles are drawn consecutively. Assume that the first marble is not put back in the bag before the second marble is drawn. Order of the selection matters. In other words, BG and GB are two different selections.

13. When choosing an outfit, you have a choice of 3 shirts: white (W), black (B), or patterned (P); a choice of 2 types of jeans: faded (F) or dark wash (D); and a choice of 4 pairs of shoes: sandals (S), running shoes (R), climbing boots (C), or mules (M). List the sample space in regard to the outfits (combination of shirt, jeans, and shoes) you could pick from.
14. When ordering pizza for a party, you have the choice between three restaurants: Dominos (D), Pizza Hut (P), and Papa John's (J); a choice of delivery (d) or store pickup (p); and side options of breadsticks (b), wings (w), or salad (s).
15. Tickets for an outdoor orchestra concert can be purchased for pavilion seating (P) or lawn seating (L). When purchasing tickets, you can choose to pay extra for a parking pass for the close lot (C) or opt for the free general parking pass (G). You can also add on meal and drink vouchers (M) or choose not to purchase any food vouchers (N).
16. You are purchasing a jigsaw puzzle from a local bookstore. The puzzles come in four sizes: 200 piece (2), 500 piece (5), 1000 piece (10), and 1200 piece (12). Each puzzle size has five images to choose from: space (S), landscapes (N), cars (C), animals (A), and bridges (B).
17. A small company is choosing packaging materials for a new product. For the box, the options are a recycled cardboard box (C), a recycled plastic box (P), or a box made from new materials (N). For the instruction manual, the options are a card with a link to online instructions (O) or a fully printed manual (M). Finally, the box can be sealed with temper resistant stickers (T) or staples (S).

Determine whether each probability is experimental or classical.

18. In order to find the percentage of bass that Troy had in his pond this spring, he decided to spend three days catching a total of 15 fish each day and counting how many of those were bass.
19. Jason wants to know how likely he is to win a raffle if he bought 3 of the 1000 tickets that were sold.
20. Virginia wants to know how likely it is for her to win a backgammon game if she only needs to roll a double six to win.
21. Emre wants to see how many students own a smartphone. He surveys 100 college freshmen at a Winter Welcome event and asks what kind of phone they carry.
22. Richard wants to determine the probability that a red Skittle will appear in a bag of regular Skittles, so he purchases 20 bags of Skittles and counts how many red Skittles are in the bags.
23. Rita volunteers at a local shelter and wonders what the probability is that someone chooses to adopt a cat from the local shelter today, so she counts how many total animals they have for adoption and the total number of cats available for adoption.

 APPLICATIONS

Calculate each experimental probability. Round your answer to the nearest millionth, if necessary.

24. A news organization asked a selection of voters exiting a polling place their age bracket in order to paint a picture of turn out on election day. Here's the record of the results collected so far.

Voting Age			
17–29	30–44	45–64	65 and Older
9	8	32	15

- What is the probability that the next voter to exit will be between 30 and 44?
  - What is the probability that the next voter to exit will be in either of the youngest two age groups?
  - What is the probability that the next voter to exit will be under 65?
25. The blood types of 200 people are collected at a doctor's office. The table shows the breakdown of patients per blood type. If a person from this group is selected at random, what is the probability that this person has type O blood?

Blood Type Survey Results	
Blood Type	Number of Patients
A	50
B	65
O	70
AB	15

26. As students were exiting the student center on campus, Vicki took note whether they were listening to headphones. The table shows results that she collected.

Based on Vicki's data, what is the probability that a randomly selected student will have headphones in their ears when exiting the student center?

Data for Students Exiting the Student Center	
	Number of Students
Headphones	33
No Headphones	51

27. A sample of 500 active-duty military showed that 82 of them suffered from Post Traumatic Stress Disorder (PTSD). However, 95 of those studied reported that they would be too embarrassed to seek mental health services.
- Based on this sample, if a soldier is chosen at random, what is the probability that he/she suffers from PTSD?
  - Based on this sample, if a soldier is chosen at random, what is the probability that he/she would be willing to seek mental health services?

28. The owner of a parking lot takes an inventory of the 150 cars parked in the lot one evening. The table shows the breakdown of cars by brand. If a car from this group is randomly selected, what is the probability that it is a Nissan?

Cars Parked in Parking Lot	
Brand	Number of Cars
Chevrolet	20
Ford	18
Honda	42
Hyundai	26
Nissan	44

29. The favorite donut flavors of 225 people are collected at a donut shop. The table shows the breakdown of the number of customers that prefer each flavor. If a flavor is selected at random, what is the probability that it is maple dipped?

Donut Flavor Survey Results	
Flavor	Number of Customers
Chocolate Sprinkle	57
Cream-filled	31
Cruller	36
Glazed	51
Jelly-Filled	32
Maple Dipped	18

30. A librarian walked through the quiet area of the university library and recorded whether students were studying or looking at their phones. The table shows the data that was collected. Based on this data, what is the probability that a randomly selected student was looking at their phone instead of studying?

Data for Students in the Library	
	Number of Students
Studying	47
Looking at Phone	22

31. A restaurant at a mall gives out free samples in hopes of gaining new customers. The employee giving out samples for an hour recorded whether the people who took a sample ordered food from the restaurant or not. The table shows the data that was collected. Based on this data, what is the probability that a person who takes a sample will order food from the restaurant?

Data for People Who Took a Sample	
	Number of People
Ordered Food	38
Did Not Order Food	77

For each situation, draw a tree diagram to determine the sample space and then calculate the given probability.

32. When ordering the three-course lasagna special at a restaurant, customers have the choice between soup (S) or salad (A) for an appetizer, meat lasagna (M) or vegetarian lasagna (V) for the main course, and cake (C) or pie (P) for dessert. What is the probability of someone ordering salad, vegetarian lasagna, and pie?
33. When picking dinnerware to add to their wedding registry, a couple decides they want white dinner plates. The couple can choose between square plates (S) or round plates (R); gold-banded plates (G), silver-banded plates (B), or plain plates (P), and glazed earthenware (E) or ceramic (C). What is the probability the couple will pick any type of glazed earthenware plates?

Calculate each classical probability. Assume individual outcomes are equally likely. Round your answer to the nearest millionth, if necessary.

34. What is the probability that, out of 235 attendees (including yourself) at a conference, you are selected to win the door prize at the opening session?
35. On an American roulette wheel, there are 18 red pockets, 18 black pockets, and 2 green pockets. What is the probability of landing on a red pocket?
36. What is the probability that a card drawn randomly from a standard deck of cards will be an ace?
37. A book contains 321 pages numbered 1, 2, 3, . . . , 321. If a student randomly opens the book, what is the probability that the page's number has all of its digits the same (ignoring single-digit page numbers)?
38. Consider a cat with a litter of four kittens. Find the probability that all four kittens are male.
39. Mason has 213 songs in a playlist. He's categorized them in the following manner: 20 from soundtracks, 8 spiritual, 31 jazz, 16 Latin American, 27 R&B, 47 rock, and 64 pop. If Mason puts his playlist on shuffle, what is the probability that the first song played is a pop song?
40. Landon decided to play a joke on his friends at work. When he stocked the vending machine with sodas, he randomly put the drinks into the different slots. If he put in 15 Diet Coke, 15 Coke, 12 Sprite, 17 Dr. Pepper, and 10 Fanta cans, what is the probability that the next person will get a Fanta drink when they put their money into the machine?
41. A shelf of fiction books contains 15 fantasy books, 12 science-fiction books, and 9 historical fiction books. What is the probability that a book selected at random is science-fiction?
42. A bag of apples picked from an orchard contains 8 Honeycrisp, 9 Gala, 7 Red Delicious, and 10 Granny Smith. If an apple is selected at random, what is the probability that it will be a gala apple?

43. To divide a class into groups for a project, numbers are placed into a box. Each student selects a number which assigns them to a group. In the box, there are six 1s, six 2s, six 3s, and six 4s. The first student selects a number at random. What is the probability that the student draws a 3?
44. An American roulette wheel has slots marked with a number 1 through 36 along with 0 and 00. The 0 and 00 slots are colored green. Half of the remaining slots are black and the other half are red. If a roulette ball randomly stops on a slot, what is the probability that the slot is red?
45. Lunch is served at a seminar and consists of a variety of sub sandwiches boxed with potato chips and a chocolate chip cookie. There are 14 turkey sandwiches, 16 ham sandwiches, and 8 roast beef sandwiches.
- What is the probability that a randomly selected lunch box contains a ham sandwich?
  - What is the probability that a randomly selected lunch box contains a chocolate chip cookie?
  - What is the probability that a randomly selected lunch box does not contain a roast beef sandwich?
46. A store sets up a display featuring the favorite movies of the employees. The display contains 12 action movies, 8 romances, 5 science-fiction movies, and 7 dramas.
- What is the probability that a randomly selected movie is a science-fiction?
  - What is the probability that a randomly selected movie is a documentary?
  - What is the probability that a randomly selected movie is not an action movie?

 **WRITING & THINKING**

47. Compare and contrast classical probability and experimental probability.

## 10.1 PROJECT

### HOW HARD IS BASEBALL COMPARED TO OTHER SPORTS?

Many say that baseball, which is commonly called America's national pastime, is a game with a low success rate. Consider Mookie Betts, one of the greatest players the sport has ever seen. He had a batting average (BA) of .346 during the 2018 season. His batting average was the highest of all players for that year.

A player's batting average is computed by dividing the number of times a player has a hit by the player's total number of at-bats.

$$\text{BA} = \frac{\text{Number of Hits}}{\text{Number of At-Bats}}$$

Notice that this formula looks a lot like a probability where the sample space is the set of all at-bats and the event is getting a hit.

## 10.2 Exercises

### ✓ CONCEPT CHECK

- When there are several outcomes at each stage of an experiment, as we saw with the start watch example in the first section, you can \_\_\_\_\_ together the number of possible outcomes at each stage of the experiment in order to obtain the total number of outcomes for the experiment.
- An experiment where repetition of outcomes is permitted is considered to be an experiment \_\_\_\_\_.
- The factorial of a number is the \_\_\_\_\_ of all the positive integers less than or equal to that number.
- When a selection of objects from a group is being made and order is not important, this is a \_\_\_\_\_. If order is important, it is a \_\_\_\_\_.
- True or False:  $0! = 1$ .

### 💡 PRACTICE

Evaluate each factorial expression.

- |                               |                               |                        |
|-------------------------------|-------------------------------|------------------------|
| 6. $5!$                       | 7. $9!$                       | 8. $\frac{8!}{6!}$     |
| 9. $1!$                       | 10. $0!$                      | 11. $\frac{10!}{2!4!}$ |
| 12. $\frac{6!}{2!3!}$         | 13. $\frac{7!}{4(9-6)!}$      |                        |
| 14. $\frac{12!}{10!(12-10)!}$ | 15. $\frac{17!}{12!(15-10)!}$ |                        |

Evaluate each permutation or combination.

- |   |   |                               |                               |
|---|---|-------------------------------|-------------------------------|
| 16. ${}_8P_2$                               | 17. ${}_7P_4$                               | 18. ${}_5P_1$                 | 19. ${}_4P_4$                 |
| 20. ${}_3C_2$                               | 21. ${}_{30}C_1$                            | 22. $\frac{{}_3C_2}{{}_3P_2}$ | 23. $\frac{{}_5P_3}{{}_5C_3}$ |
| 24. $\frac{{}_5C_3}{{}_5C_2}$               | 25. $\frac{{}_5P_3}{{}_5P_2}$               | 26. $\frac{{}_6P_4}{{}_6C_2}$ | 27. $\frac{{}_7C_3}{{}_7P_3}$ |
| 28. ${}_7C_4 + {}_7C_3 + {}_7C_2 + {}_7C_1$ | 29. ${}_7P_4 + {}_7P_3 + {}_7P_2 + {}_7P_1$ |                               |                               |

 APPLICATIONS

30. How many three-digit area codes can be made from the digits 0 through 9? Assume that the digits may repeat and that area codes beginning with 0 are allowed.
31. How many three-digit area codes can be made from the digits 0 through 9 if the first digit is not allowed to be a 0 and the digits are allowed to repeat?
32. How many six-character password codes are possible if you are allowed both lowercase letters and the digits 0 through 9, and repeating characters are allowed?
33. When ordering a new e-reader, you have several choices to make. You can choose from five price ranges, decide between Wi-Fi and 3G, choose to have a one-year or three-year warranty, and pick a black, white, or silver casing. How many possible e-readers are there for you to choose from?
34. The Youngs are planning their next family night. They always have dinner out somewhere and then do something fun together. There are two adults and four boys in the family. Each family member is allowed two meal suggestions, and each boy is allowed three activity suggestions. Assuming no family members choose the same thing, how many different family night possibilities are there?
35. If there are seven children lining up for recess, how many different ways can they line up?
36. The college's soccer team will play 11 games next fall. Each game can result in one of three outcomes: a win, a loss, or a tie. Find the total possible number of outcomes for the season record.
37. Harper is deciding on her schedule for next semester. She must take each of the following classes: English 102, College Algebra, History 102, and Biology 101. If there are 16 sections of English 102, 14 sections of College Algebra, 7 sections of History 102, and 12 sections of Biology 101, how many different possible schedules are there for Harper to choose from? Assume there are no time conflicts between the different classes.
38. If there were no restrictions on the use of the number zero, in theory, how many seven-digit telephone numbers are possible?
39. How many four-digit even whole numbers exist?
40. In the new ice creamery, several choices need to be made before tasting "a little bit of heaven," as the advertisement suggests. First, there are three cup sizes to choose from, then 39 different ice cream flavors to decide from, and finally several mix-ins to choose from: 10 candy bars, 8 fruits, 8 nuts, and 10 cookies or cakes. If you want a medium cup with one flavor of ice cream and two mix-ins, one candy bar, and one nut, how many possible choices are there for you to have your "taste of heaven"?

41. As part of a fundraising campaign, a city's parks and recreation department is selling bicycle license plates featuring the blueprint of a future park. Each license plate has unique and consists of 2 capital letters followed by 2 numbers (from the digits 0 through 9).
- Determine the number of possible unique license plates if letters and numbers are allowed to be duplicated.
  - In an effort to decrease the number of license plates available, a decision was made to not allow any duplicates of letters or numbers on the license plates. Determine how many unique license plates are possible under this new rule.
42. A 5th grade class is choosing books to read for upcoming book reports. Each student has to complete two book reports. They must select two books from a selection of 20 books, then they must pick two book report formats from the following options: written report, poster, or shoebox diorama.
- If the teacher does not specify that the books and report types must be unique, how many possible combinations are there for a student to choose from?
  - If the teacher specifies that the books and the report types must be unique, how many possible combinations are there for a student to choose from?
43. A bakery has 10 different cupcake flavors and sells boxes that hold 4 cupcakes. How many different ways are there to fill a box with 4 cupcakes?
44. Suppose a bakery has 10 different cupcake flavors and sells variety boxes of 4 cupcakes. The variety boxes have the restriction that the same flavor cannot be added to the box back-to-back. (For example, if a chocolate cupcake with vanilla frosting is the first cupcake placed into the box, then the next cupcake placed into the box cannot be a chocolate cupcake with vanilla frosting.) How many different variety boxes of cupcakes can be created?
45. To determine the theme for a short story, an author places 15 different plot ideas into a box and draws out 3, placing each idea in order on a table. The author then writes a story that progresses through those 3 ideas. Determine how many possible short story topics can be created using this method.
46. A personal trainer creates a challenge for his clients where each client must choose one of five exercises to perform each day for three weeks (21 days). How many different ways can a client complete the month-long challenge?

Determine whether to use a permutation or combination to answer each question, and then determine the total number of outcomes.

47. There are 10 board members on the Community Arts Council. In how many ways can a president and treasurer be chosen? Assume that no member can hold both positions at the same time.
48. In how many ways can a committee of five people be chosen from a pool of 120 employees?

49. If there are 84 runners in a race, in how many ways can 1st, 2nd, and 3rd place ribbons be given out?
50. Elliot has to submit three photographs for the school art show. This semester he has taken 29 photographs that he thinks are show-worthy. In how many ways can he choose the photographs to submit?
51. Avery was born on 10/15/1995. How many eight-digit codes could she make using the digits in her birthday?
52. There are 18 tenured faculty in the biology department on campus. The department needs one tenured faculty member to facilitate undergraduate research, one member to supervise graduate advising, and one to coordinate grant proposals. In how many ways can these tasks be assigned, if a member may be appointed to only one duty?
53. A service organization on campus needs a group of six students from their organization's membership of 123 students to serve as program attendants at graduation. In how many ways can the attendants be chosen?
54. In how many ways can the letters in the word STATISTICS be arranged?
55. In how many ways can the letters in the word TENNESSEE be arranged?
56. A bookstore has a buy three get one free sale on used books. If the current selection of used books contains 18 unique books, how many different groups of four books can be chosen to qualify for the sale?
57. If a talent show has 12 contestants, in how many ways can the prizes for first, second, and third place be awarded?
58. A company is considering using a new productivity management system and wants to test out the latest system on a group of four employees. If the company has 50 employees, how many ways can the test group be selected?
59. A designer needs to select four colors to use to create a poster for an upcoming event. After some brainstorming, she comes up with eight different colors to use, all of which go together. How many different ways can she choose four colors from the eight possible colors?
60. An ice cream store can create 25 different flavors onsite but their display freezer limits the store to only selling 10 flavors per day. How many different flavor combinations can be created per day?
61. A movie theater's newest promotion is an early-bird classics week where a different classic movie is played each morning for a week (seven days). If the theater has the rights to show twenty different classic movies, how many different ways can seven movies be shown during the week?
62. The Renfield family is staying at a resort for their annual vacation. As part of the resort package, the family can choose three of twenty different excursions to go on from options such as zipline tours, guided hikes, and sundown bat watching. How many ways can the family choose which excursions to go on?

63. An instructor is creating a 10-question quiz where 6 questions are true and 4 are false. How many different ways can the questions be arranged in the quiz?
64. Naval signs are made by arranging colored flags in a vertical line. Using 6 flags, how many distinct symbols can be made if you have 2 red flags, 3 green flags, and 1 blue flag?
65. Allison purchases a variety pack of mochi ice cream that contains the following flavors: 2 salted caramel, 2 mango, 4 vanilla, and 4 chocolate. If she plans to eat one mochi per day, how many flavor arrangements are possible?

 **WRITING & THINKING**

66. Without calculating the permutations, decide which of the following words would produce the greatest number of four-letter arrangements.
- PASS
  - TEST
  - FAIR
  - FREE
67. Determine how many ways a group of three students from your class could be selected.

## 10.2 PROJECT

### PASSWORDS AND SECURITY: DO HACKERS TEST ALL POSSIBILITIES?

Mark Zuckerberg, the founder and CEO of Facebook, is known to have kept “dadada” as his Twitter and Instagram passwords. Simple passwords of this type are a treat for hackers trying to gain access to an account. These passwords can be guessed in a short amount of time by what is called a dictionary attack. In this case, an intruder tests common words and their combinations until the correct password is found.

What about more secure passwords? Is it possible to simply test all possibilities for a password and gain access to someone’s account? In this activity, you will estimate the time it would take to correctly guess a social media account password.

Assume that a social media platform requires your password to have exactly 8 characters selected from any of the 26 letters of the alphabet, the numbers 0 through 9, and any of the characters #, \$, %, or &. In order to simplify our computations, let’s assume repetitions are allowed.

- Determine the number of distinct passwords that can be created using the requirements described above. The number is very large, so you should use a calculator or computer for your computation.

**Table 10.3.3:** 2020 WNBA Finals Odds and Probability

Team	Odds	Probability of Losing Money
Seattle Storm	1 : 2	$\frac{1}{3} \approx 0.3333$
Las Vegas Aces	9 : 2	$\frac{9}{11} \approx 0.8182$
Connecticut Sun	11 : 2	$\frac{11}{13} \approx 0.8462$
Minnesota Lynx	18 : 1	$\frac{18}{19} \approx 0.9474$

Notice that these probabilities add to more than 1 and we've only included 4 of the 12 teams. Remember that this is not the probability that a team will win the WNBA finals, but an assessment by the bookie of the probability that you will lose a money on a bet for that team.

- b. The team that has the smallest probability of losing money for a bet is the team most likely to win. Therefore, the Seattle Storm was the team most likely to win the 2020 WNBA finals. Their odds of 1 : 2 mean that for each \$2 bet, you would win \$1.
- c. Since the odds for the Connecticut Sun are 11 : 2, for every \$2 bet, a bet would win \$11. Therefore, we need to divide the bet by \$2 and then multiply by \$11 to determine the amount that would be won.

$$\text{Winnings for a \$50 Bet on the Connecticut Sun: } \frac{\$50}{\$2} \cdot \$11 = \$275$$

### ✓ Skill Check 10.3.3

If the odds on a bet are 4 : 1 against, what is the probability of winning?

### Skill Check Answers

1.  $P(E) \approx 0.000292$  2. e 3.  $\frac{1}{5}$  or 20%

## 10.3 Exercises

### ✓ CONCEPT CHECK

- If you combine the outcomes from a set and its \_\_\_\_\_, you will have the entire sample space.
- The sum of all the probabilities of all the outcomes in a sample space must equal \_\_\_\_\_.
- There are two ways that odds are given: odds \_\_\_\_\_ and odds \_\_\_\_\_.
- When you are given the odds \_\_\_\_\_ (when it comes to betting) you are being told the ratio of the probability of losing money to the probability of winning money.
- True or False: If the odds of something happening are 1:2, that means that the probability of it happening are 50%.

 APPLICATIONS

6. Find the probability that three people randomly line up to buy tickets in order of their height (tallest, middle, shortest). Assume that no two people in the line are of the exact same height.
7. One option to play the lottery is called “3-way any order.” In order to play this method, you select three digits, from 0 to 9, such that precisely two of the digits are the same (for example, 1, 1, 2). You’re a winner if your three digits show up in any order in the lottery’s three randomly chosen digits. Digits may be repeated when the lottery chooses the winning number. Find the probability of winning with the “3-way any order” method.
8. Another option of playing the lottery is to choose three numbers (allowing repetition) in the exact order they will appear. Find the probability of winning the lottery with one ticket.
9. Ian is playing Scrabble. What is the probability that the next three letters he draws from the bag spell out his name in the order that he draws them? Assume there is one of each letter in the alphabet left in the bag.
10. There are two sets of balls numbered 1 through 5 placed in a bowl. If two balls are randomly chosen without replacement, find the probability that the balls have the same number.
11. William and Gavin are going to play video games after work. Together they have 48 games. If they decide to randomly choose two games to play, what is the probability that the two games they choose consist of William’s favorite game and Gavin’s favorite game? Assume they have different favorites.
12. A local pizza parlor has the following list of toppings available for selection. The parlor is running a special to encourage patrons to try new combinations of toppings. They list all possible three-topping pizzas (three distinct toppings) on individual cards and give away a free pizza every hour to a lucky winner.

**Pizza Toppings**

Green Peppers	Onions	Pepperoni	Sausage
Baby Portabello Mushrooms	Black Olives	Ham	Spicy Italian Sausage
Roma Tomatoes	Pineapple	Beef	Grilled Chicken
Jalapeño Peppers	Banana Peppers	Bacon	Extra Cheese

- a. How many three-topping pizza cards are there?
  - b. Find the probability that the first winner randomly selects the card with the pizza containing green peppers, ham, and bacon on it.
13. A combination padlock is a lock in which a sequence of numbers is used as the “key” to open the lock. Suppose a combination padlock has 10 digits to choose from for each of the four sections of the lock.
    - a. Does the “key” for a combination padlock involve permutations or combinations?
    - b. How many possible “keys” are there for the combination padlock?
    - c. What is the probability that you randomly buy one of these locks whose “key” is made of 4 of the same digit?

14. Four students, three girls and a boy, have arranged to meet on the first day of class and sit in the front row. Suppose they agree to sit in the first four seats in the order that they arrive.
  - a. How many possible seating arrangements are there for the four friends?
  - b. What is the probability that all three girls end up sitting next to one another?
15. A bakery has 20 unique donut flavors but only sells 5 flavors per day. If the flavors are chosen at random, determine the probability that the flavors selected for today are s'mores, crème brûlée, very vanilla, strawberry shortcake, and chocolate dream.
16. An introduction to rock climbing class is divided up into groups of 3 for rappelling practice. Out of the 12 people in the class, 3 are complete beginners. What is the probability that all three beginners are placed in the same group?
17. An instructor is creating the syllabus for the upcoming semester and must choose 5 chapters to cover out of a 10-chapter math textbook. What is the probability that the instructor chooses to cover topics in the following order: set theory, logic, finance, probability, and statistics?
18. Three friends, Allen, Paul, and Trey, are sitting in a room with nine other people waiting for their turn to audition for an upcoming reality show. What is the probability that the next three people called to audition are Allen, Paul, and then Trey?
19. In the game of Texas hold'em poker, a hand is made up of two cards from a deck of 52. What is the probability of being dealt a 2 of clubs and a 7 of hearts?
20. The drama department at a school is selecting plays to perform for the year. They can choose one play for the fall and another play for the spring. If the department holds the rights to perform 22 different plays, what is the probability that they select Romeo and Juliet and Clue?
21. As a sandwich aficionado, you believe that the order in which the ingredients are placed influences the overall flavor of the sandwich. If you order a turkey club sandwich, what is the probability that the ingredients are, from bottom to top, turkey, cheese, bacon, lettuce, tomato, and mayo?
22. The producers for an awards show plan to have a commercial break after every two awards presented. During the first hour, they decide to present the awards for best leading actor, best supporting actor, best leading actress, best supporting actress, best overall cast, and best script. What is the probability that the awards for best overall cast followed by best supporting actress are presented before the first commercial break?
23. A committee of four is being formed randomly from the employees at a school: 5 administrators, 37 teachers, and 4 staff.
  - a. How many ways can the committee be formed?
  - b. What is the probability that all four members are staff?
  - c. What is the probability that no member is an administrator?

24. A hand of poker is made up of five cards from a standard deck of cards.
- How many possible hands of poker are there in a standard deck of 52 cards?
  - A royal flush consists of the cards Ace, King, Queen, Jack, and ten, all in the same suit. What is the probability of being dealt a royal flush?
25. Matthew needs to set the pass code on his smartphone. It must be a four-digit number and repeated digits are allowed.
- How many possible pass codes are there for Matthew to choose from?
  - How many possible pass codes are there for Matthew if he decides to choose four distinct numbers?
  - A spy sneaks a look at Matthew's phone and sees his fingerprints on the screen over four numbers. What is the probability that the spy is able to unlock the phone on his first try?
  - The spy knows the fingerprint trick and so on his phone he uses a repeated digit in his code. If you could see the three fingerprints on the spy's phone, what is the probability that you could unlock the phone on your first attempt?
  - Based on parts **c.** and **d.**, is it better to repeat a digit or have four distinct digits in the code on your phone for security purposes?
26. A hand of blackjack consists of two cards. The dealer deals you a hand from a fresh deck.
- What is the probability that the two cards have the same face value, for instance, both cards are Kings or both cards are 5s?
  - If aces count 1 or 11, picture cards count 10, and card numbers 2 through 10 are equal to their face value, what is the probability that the two cards sum to 21?
27. For a pick-up game of basketball, jerseys are in a box and people start grabbing them. The box contains three extra-large, seven large, and four medium jerseys. If you are first to the box and grab two jerseys, what is the probability that you randomly grab two extra-large jerseys?
28. A junk drawer at home contains a half-dozen pens, two of which work. What is the probability that you randomly grab two pens from the drawer and don't end up with a pen that works?
29. A city activity committee is planning to show one movie per week at a local park for five weeks during the summer. The committee decides that this year's theme is comedy movies and can choose from five PG rated comedies and six G rated comedies.
- In how many ways can the movies be selected?
  - In how many ways can the movies be selected if three must be G rated and the other two must be PG rated?
  - Suppose that the movies are selected at random with no restrictions. What is the probability that three G rated movies are selected and two PG movies are selected?

30. A book club reads one book per month. The book selection committee of the club is assigning the books they will read over the next six months. The overall book selection includes six fiction books and seven nonfiction books.
  - a. In how many ways can the books be selected?
  - b. In how many ways can the books be selected if three books must be fiction and three books must be nonfiction.
  - c. Suppose the books are selected at random with no restrictions. What is the probability that the selection contains three fiction and three nonfiction books?
31. A bag contains each letter of the alphabet. Find the probability that a randomly selected letter from the bag will not be one of the five vowels.
32. Find the probability of randomly choosing a letter other than the letter O from a bag that contains the eighteen letters of the Italian city GUIDONIA MONTECELIO.
33. Using the table containing the breakdown of all employees on nonfarm payrolls in the United States during March 2014, find the probability that a randomly selected US worker was not in either retail trade or wholesale trade.

**Employees on Nonfarm Payrolls (in Thousands), March 2014**

		Area of Employment	Number of Employees (in Thousands)
<b>Private Sector</b>		Goods-Producing	18,558.2
		Wholesale Trade	5803.7
		Retail Trade	15,004.0
		Transportation and Warehousing	4524.8
		Utilities	550.3
		Information	2653.0
		Financial Activities	7870.0
		Professional and Business Services	18,832.0
		Education and Health Services	21,481.0
		Leisure and Hospitality	14,143.0
		Other Private Service-Providing Services	5464.0
<b>Public Sector</b>		Federal Government	2705.0
		State Government	5217.0
		Local Government	14,341.0
		<b>Total Nonfarm Employees</b>	<b>137,147.0</b>

**Source:** Bureau of Labor Statistics. "Table B-1. Employees on nonfarm payrolls by industry sector and selected industry detail." Accessed June 2014. <http://www.bls.gov/news.release/empsit.t17.htm>

34. In June 2011, the week of the final mission of the US space shuttle program, a Pew Research poll asked 1502 US adults whether the United States must continue to be a world leader in space exploration. The following table gives a breakdown of their opinions.

The United States Continuing to be a World Leader in Space Exploration is . . .		
Essential	Not Essential	Don't Know
871	571	60

**Source:** Pew Research Center. "Majority Sees U.S. Leadership in Space Essential." July 5, 2011. <http://www.people-press.org/2011/07/05/majority-sees-u-s-leadership-in-space-as-essential/>

- a. Find the probability that someone responded "essential."  
 b. Find the probability that someone did not respond "essential."
35. Find the probability of rolling two dice and not getting the same number on both dice.
36. Suppose a family has five pets. Find the probability that at least one of the pets is male.
37. The weather report says there is a 25% chance of rain this evening. What is the probability that it does not rain this evening?
38. There is a 12% chance that all of the strawberries in a container are moldy. What is the probability that some of the strawberries are not moldy?

Use the data in the table to determine the following probabilities.

US Import Sources by Weight (in Pounds) for Frozen Blackberries in 2019	
Chile	17,303,000
Mexico	4,542,000
Serbia	3,705,000
China	169,000
Other Countries	514,000

**Source:** USDA. "Fruit and Tree Nut Data." <http://www.ers.usda.gov/data-products/fruit-and-tree-nut-data/data-by-commodity.aspx>

39. What is the probability that frozen blackberries purchased in the United States during this period were from Serbia or China?
40. What is the probability that frozen blackberries purchased in the United States during this period were not from Chile?
41. If the odds on a bet are 6 : 1 against, what is the probability of winning?
42. Suppose the probability of a football team winning a playoff game is 0.25. What are the odds of winning?
43. The odds of a teenage male having an accident are 2 : 3. What is the probability of a teenage male having an accident?

44. An insurance company claims the probability of surviving a certain type of cancer is 95%. What are the odds of surviving?
45. The UVest investment company publishes that the odds of increasing your wealth with their company is 5 : 2. What is the probability of UVest increasing your investment?
46. Odds against being struck by lightning in one year are 1,000,000 to 1.
- If you live to be 80, what are the odds against being struck by lightning over your lifetime? Assume each year has the same probability.
  - The National Weather Service gives the odds against being struck by lightning over an 80-year lifetime as 10,000 to 1. Why do you think this is different from the answer you got in part **a.**?
47. Overall odds in favor of winning in a state lottery game are 4.63 : 1.
- Find the probability of winning in the lottery game.
  - The prize for this lottery game is \$100. If the cost to play the game is \$2.00, what is the expected value for playing this game?
48. Suppose the odds on a bet are 10 : 1 against. Your friend tells you he thinks the odds are too generous. Odds are considered less generous if the probability of losing is greater. Write down some less generous odds.
49. Some of the odds to win the 2021 Palmetto Championship are listed in the table.

Odds to Win 2021 Palmetto Championship	
Player	Odds Against
Brooks Koepka	9 : 1
Dustin Johnson	8 : 1
Matthew Fitzpatrick	16 : 1
Sungjae Im	20 : 1
Tyrrell Hatton	14 : 1

**Source:** "Golf Futures Betting Odds," Vegas Insider, accessed June 11, 2021, <https://www.vegasinsider.com/golf/odds/futures/>

- Determine the probability of losing money on a bet for each of the players listed.
- Based on these odds, which player was most likely to win the 2021 Palmetto Championship?

50. Some of the odds to win the 2021 Kentucky Derby are listed in the table.

Odds to Win 2021 Kentucky Derby	
Horse	Odds Against
Rock Your World	9 : 2
Essential Quality	3 : 1
Medina Spirit	12 : 1
Known Agenda	10 : 1
Hot Rod Charlie	6 : 1

**Source:** "2021 Kentucky Derby Betting Odds & Results," Vegas Insider, accessed June 11, 2021, <https://www.vegasinsider.com/horse-racing/odds/kentucky-derby/>

- Determine the probability of losing money on a bet for each of the horses listed.
- Based on these odds, which horse was most likely to win the 2021 Kentucky Derby?

### WRITING & THINKING

- Describe the complement of the set of odd numbers greater than 0 within the set of positive integers.
- Let the event  $E$  be the sum of a pair of dice that is divisible by 3. List the events in  $E^c$ .
- The following is a table of the ages of boys on a soccer team.

Let  $A = \{\text{soccer players older than 9}\}$ . How many players are in the complement of  $A$ ?

Ages of Boys on Soccer Team	
Age	Number of Boys
8	3
9	6
10	7
11	2

- Describe the complement of the set of face cards in a standard deck of cards.
- In a company, all employees who have worked there for more than five years receive a gift. Describe the complement of this group of employees.
- In a bookstore, all books released in the past year that are currently on the best sellers list are placed on a table near the entrance. Describe the complement of this set of books.

## 10.4 Exercises

### ✓ CONCEPT CHECK

1. If  $A$  and  $B$  are events that have some outcomes in common, then the probability that  $A$  or  $B$  will happen is calculated by adding the individual probability of each and then \_\_\_\_\_ the probability that both events occur simultaneously.
2. If two events have \_\_\_ outcomes in common, they are called mutually exclusive events.
3. The probability of events  $A$  and  $B$  happening is equal to the probability of  $A$  happening times the probability of  $B$  happening IF the two events are \_\_\_\_\_.
4. \_\_\_\_\_ probability is the probability of one event happening given that another event has already happened.
5. True or False: If the result of one event influences the probability of a second event, the two events are independent.

### 💡 PRACTICE

Determine whether each situation contains mutually exclusive events.

6. Let event  $A$  consist of numbers that are prime. Let event  $B$  consist of numbers that are multiples of 5.
7. Let event  $A$  consist of the multiples of 3. Let event  $B$  consist of the factors of 10.
8. Let event  $A$  consist of randomly selecting a member of a concert audience who can play the guitar. Let event  $B$  consist of randomly selecting a member of a concert audience who cannot play the guitar.
9. Let event  $A$  consist of rolling a die and getting a 3. Let event consist of rolling a die and getting a 6.

Determine whether each situation contains independent events.

10. The color of car driven by three randomly chosen classmates.
11. A password must be six characters long with no repeated characters. Are the choices of consecutive characters independent?
12. There are 15 board members, of which seven are men and eight are women. Two randomly chosen members will serve on the United Way campaign committee. If you wish to find the probability that both members chosen are the same sex, do you treat these selections as independent events?

13. Are receiving a bill in Monday's mail and receiving a letter from your grandparents in Monday's mail independent events?
14. Naomi and Amelia both put two business cards into the basket at a coffee shop. The shop owner selects three cards from the basket. Are the two events that Naomi's card is chosen and Amelia's card is chosen independent?

### APPLICATIONS

Calculate the probability of each set of events that are not mutually exclusive. Round your answer to the nearest millionth, if necessary.

15. A pair of dice is rolled. What is the probability that the sum of the numbers is an even number or a multiple of 3?
16. A bag of eleven marbles contains five marbles with red on them, three with green on them, seven with black on them, and four with black and red on them. What is the probability that a randomly chosen marble has either black or red on it?
17. What is the probability that a card selected from a deck will be either an ace or a spade?
18. The following is a table showing the results of a poll taken on campus.

Will You Vote in the Upcoming Election?		
	Male	Female
Yes	16	24
No	19	11
Not decided	21	22

- a. What is the probability that a randomly selected student from this poll would be a male who has not decided whether he will vote in the upcoming election?
- b. What is the probability that a randomly selected student from this poll is female or will not vote in the upcoming election?
- c. What is the probability that a randomly selected student from this poll has decided to vote in the upcoming election?
19. Out of a class of 30 students, there are 16 students who study Latin, 21 who study German, and 7 who study both. What is the probability that a randomly selected student from the class will study only Latin?
20. Of the 11 instructors in the English department, four are new to the department and three are female. However, there is only one who fits all of the descriptions. Find the probability that if you randomly choose a course taught by these instructors, you get either a new instructor or a female instructor.

21. The following is a table representing the students who are on the Student Government Board.

Students on the Student Government Board		
	On-Campus Housing	Off-Campus Housing
Freshman	3	1
Sophomore	3	2
Junior	2	3
Senior	0	3
Graduate Student	0	2

Find the probability that a randomly chosen member of the Student Government Board is either a sophomore or lives in on-campus housing.

22. A box of a dozen chocolates contains 8 chocolates that contain nougat, 6 that contain caramel, and 2 that contain both caramel and nougat. Determine the probability that a randomly selected chocolate will contain only nougat.
23. A pair of dice is rolled. What is the probability that the sum of the numbers is divisible by 5 or a prime number?
24. A bag of meeple game pieces contains 10 meeples with yellow on them, 20 meeples with blue on them, 12 meeples with green on them, and 6 meeples that are striped yellow and blue. What is the probability that a randomly chosen meeple has either yellow or blue on it?
25. What is the probability that a card randomly selected from a standard deck will be either a face card or a diamond?

Calculate the probability of each set of mutually exclusive events. Round your answer to the nearest millionth when necessary.

26. Suppose that the probability of obtaining zero defective items in a sample of 50 items off the assembly line is 0.34 while the probability of obtaining 1 defective item in the sample is 0.46. What is the probability of the following?
- Obtaining no more than one defective item in a sample.
  - Obtaining more than one defective item in a sample.
27. A pair of dice is rolled. What is the probability that the sum of the numbers is either 7 or 11?
28. A single letter from the word MISSISSIPPI is chosen. What is the probability of choosing an S or an I?
29. What is the probability that a card selected from a deck will be either an ace or a queen?
30. A reporter for an international newspaper is given an assignment that is randomly chosen from the following destinations worldwide: 13 continental United States assignments, 7 South American assignments, 21 European Union assignments, and 5 Asian assignments. Find the probability that he gets an assignment in Asia or South America.

31. The following table shows the breakdown of opinions for both faculty and students in a recent survey about the new restructuring of the campus to be a walking campus.

Survey Results on Restructuring Campus to a Walking Campus				
	Favor	Oppose	Neutral	Total
Faculty	12	4	3	19
Student	33	57	28	118
Total	45	61	31	137

- a. Find the probability that a randomly selected person is either a faculty member in favor of the change or a student who has an opinion either for or against.
- b. Find the probability that a randomly selected person is either neutral or in favor of the restructuring.
32. The probability of the stoplight being green at the intersection of Meeting Street and Main Street is 0.55, while the probability of it being yellow is 0.15. Find the probability that the light is red when you get to the intersection of Meeting Street and Main Street. Assume that the light will be working and will be a solid color: red, yellow, or green.
33. In a box of pens and pencils, the probability of randomly choosing a sharpened pencil is 0.54 and the probability of randomly choosing a pen from the box is 0.39. Find the probability of randomly selecting either an unsharpened pencil or a pen from the box.
34. A couple is deciding where to spend their honeymoon. They've narrowed down their options to 4 locations in the United States, 3 locations in Mexico, and 3 locations in the United Kingdom. What is the probability of the couple choosing a honeymoon location in Mexico?
35. A community extracurricular soccer league uses volunteers for the coaching positions. This year, only 7 of the 16 volunteers have previous coaching experience. What is the probability that a team will have a coach with no previous coaching experience?

Calculate the probability of each set of independent events. Round your answer to the nearest millionth, if necessary.

36. Suppose the probability that my pet will be alive in five years is 0.65 and the probability that my cousin's pet will be alive in five years is 0.48. Find the probability that both of these pets will be alive in five years assuming that they are independent events.
37. Two dice are thrown. Find the probability of getting an even number on the first die and an odd number on the second die.

38. The following table shows the student demographics for a sociology class.

	<b>Male</b>	<b>Female</b>
<b>Freshman</b>	3	11
<b>Sophomore</b>	4	9
<b>Junior</b>	0	3
<b>Senior</b>	1	0

- a. Find the probability that a randomly selected student from the class is a male.
- b. Find the probability that if two students are randomly selected, without replacement, the first is a female junior and the second is a male sophomore.
39. Find the probability of choosing a heart and then an ace from a standard deck of cards with replacement.
40. On any given day at the beach, there is a 49% chance of precipitation. What is the probability that you will get precipitation for three days in a row on your beach vacation? Assume that the weather on a particular day at the beach is independent of the weather the day before.

Calculate the probability of each set of dependent events. Round your answer to the nearest millionth, if necessary.

41. A bag of marbles contains 7 marbles with green on them, 10 marbles with pink on them, 6 marbles with blue on them, and 3 marbles with both pink and blue on them. Two marbles are selected from the bag in a row without replacement. Determine the probability that a marble with blue and pink on it was selected first and a marble with blue on it was selected second.
42. A group of candidates are sitting in a lobby waiting to be interviewed. Six of the candidates have previous experience related to the job, eight of the candidates have a bachelor's degree, and three of the candidates have both previous experiences and a bachelor's degree. Determine the probability that the next candidate called has a bachelor's degree and previous experience followed by a candidate that only has a bachelor's degree.
43. A group of friends are deciding which two movies to watch for movie night. They narrowed their options down to 6 comedies, 5 romances, 4 action films, and 3 romantic comedies. What is the probability that the first movie they select is a comedy and the second movie they select is a romantic comedy? (Assume they will not watch the same movie twice in a row.)
44. Suppose you are trying out different types of mouthwash and the store you visit has 10 mouthwashes that contain alcohol, 7 mouthwashes that contain fluoride, 3 mouthwashes that contain neither alcohol nor fluoride, and 5 mouthwashes that contain both alcohol and fluoride. If you choose two different mouthwashes at random, what is the probability that the first mouthwash you select contains both alcohol and fluoride and the second mouthwash you select contains fluoride?

Calculate each conditional probability. Round your answer to the nearest millionth, if necessary.

45. A swim team consists of four boys and three girls. A relay team of four swimmers is chosen at random from the team members. What is the probability that there are two boys on the relay team given that there are two girls on the relay team?
46. Emma is playing Monopoly, a game played with two dice. What is the probability that the sum of the two dice she rolls is less than 4 given that she rolls an odd number?
47. Hunter bets his friend that he can draw two aces in a row from a standard deck of cards. What is the probability that Hunter draws a second ace given that his first card was an ace?
48. The probability that a student passes Intermediate Algebra is 0.55. The probability that a student passes College Algebra given that they pass Intermediate Algebra is 0.70. What is the probability that a student passes both College Algebra and Intermediate Algebra?
49. On each point in racquetball, a player is allowed two serves. Suppose while playing racquetball, Tim gets his first serve in about 75% of the time. He gets his first serve in and wins the point about 50% of the time. What is the probability that he wins the point, given that he gets his first serve in?
50. Suppose 170 people were randomly selected and asked whether their job earnings during the past month were less than \$4000 or greater than or equal to \$4000. Their responses are given in the following table.

Age	Earnings		
	<\$4,000	≥\$4,000	Unemployed
18–27	14	7	9
28–37	16	17	3
38–47	4	31	0
48–57	6	28	2
>58	12	10	11

If one response was selected at random, find the probability that it indicated that the person earned more than \$4,000.

51. Suppose 170 people were randomly selected and asked whether their job earnings during the past month were less than \$4000 or greater than or equal to \$4000. Their responses are given in the following table.

Age	Earnings		Unemployed
	<\$4,000	≥\$4,000	
18–27	14	7	9
28–37	16	17	3
38–47	4	31	0
48–57	6	28	2
>58	12	10	11

If one response was selected at random, find the probability that it indicated that the person earned at least \$4,000 given that they were of age 38 to 47.

52. Suppose 170 people were randomly selected and asked whether their job earnings during the past month were less than \$4000 or greater than or equal to \$4000. Their responses are given in the following table.

Age	Earnings		Unemployed
	<\$4,000	≥\$4,000	
18–27	14	7	9
28–37	16	17	3
38–47	4	31	0
48–57	6	28	2
>58	12	10	11

If one response was selected at random, find the probability that it indicated that the person was of age 18 to 27 given that they were unemployed.

Use Bayes' Theorem to calculate each probability. Round your answer to the nearest millionth, if necessary.

53. One of the world's most common parasites is *Toxoplasma gondii* which causes a disease called toxoplasmosis. It is possible that 50% of the world's population is infected by toxoplasmosis. Cats spread *Toxoplasma*, and about 26% of the world population own cats. If 42% of people infected by toxoplasmosis own a cat, what is the probability that a cat owner is infected by toxoplasmosis?
54. The company expects the probability of economic recovery to be 4% and the probability of the company's revenue growth due to economic recovery to be 78%. Regardless of whether the economy grows, the company's revenue will grow with a 32% probability. What is the probability that the economy has risen if the company's revenue has grown?
55. Suppose 34% of students at a certain school know French and 23% know German. The share of French-speaking students who also know German is 12%. What is the probability that a student speaks French given that he or she speaks German?

56. Major depressive disorder affects approximately 7.1% of the US population aged 18 and older. Moreover, depression is the cause approximately two-thirds of the reported suicides in the US every year. Given that 0.015% of Americans die by suicide each year, what is the probability of a person committing suicide if they have depression?

## 10.4 PROJECT

### THE PROBABILITY OF SPAM FILTERING

According to the website [statista.com](http://statista.com), 28.5% of all email traffic in 2019 was made up of spam—those pesky, useless, and potentially dangerous messages that just clog our email inboxes. Most email servers these days can filter spam automatically. Spam messages often have certain suspicious phrases in the subject lines. For example, “You Have Been Selected” is one such phrase.

An incoming email is checked for key elements, such as this phrase, then the server decides whether to put the email in your mailbox or send it to the spam folder.

In this activity, you will estimate the probability that an email with a specific subject line is classified as spam.

Let  $P(S)$  be the probability that an email you have received is spam and  $P(S^c)$  be the probability that the email is not spam.

1. According to [statista.com](http://statista.com), what were the values of  $P(S)$  and  $P(S^c)$  in 2019?

Let's assume that 10% of all spam messages contain the word *selected* in the subject line. In order to simplify our notation, we will name the events as follows.

$S$  = email is spam

$S^c$  = email is not spam

$W$  = subject line contains the word *selected*

$W^c$  = subject line does not contain the word *selected*

2. Express the statement “10% of all spam messages contain the word *selected* in the subject line” as a conditional probability.
3. We also will assume that 0.5% of all nonspam messages also contain *selected* in the subject line. Express the previous statement as a conditional probability.

Since every message can be classified as either spam or not spam, the probability that any message has *selected* in the subject line is the following.

$$P(W) = P(W | S)P(S) + P(W | S^c)P(S^c)$$

4. Compute the value of  $P(W)$ .
5. Finally, determine the probability that an email is spam, knowing it has the word *selected* in the subject line. (**Hint:** Use Bayes' Theorem.)

**Microsoft Excel**

We can use the binomial distribution function, **BINOM.DIST(number\_s, trials, probability\_s, cumulative)** to find the probability that less than half of the survey respondents voted for the current governor. This number subtracted from 1 is the probability that at least half of the respondents voted for the current governor.

In an empty cell, type “=1-BINOM.DIST(99, 200, 0.441, TRUE)” and press Enter. The value given is 0.054141885.

A1		fx		=1-BINOM.DIST(99,200,0.441,TRUE)			
	A	B	C	D	E	F	G
1	0.054141885						

**Figure 10.5.13**

Therefore, the probability that more than half of the survey respondents voted for the current governor in the last election is approximately 5.4%.

**Skill Check Answers**

1. **a.** Yes **b.** No; there are more than two outcomes. **c.** No; there is not a fixed number of trials, and the probability of getting an ace changes with each draw unless the card is replaced each time.

$$2. P(\text{At Least 4 Sixes}) = P(4 \text{ Sixes}) + P(5 \text{ Sixes}) + P(6 \text{ Sixes}) + P(7 \text{ Sixes}) \\ + P(8 \text{ Sixes}) + P(9 \text{ Sixes}) + P(10 \text{ Sixes})$$

## 10.5 Exercises

**✓ CONCEPT CHECK**

- In a binomial experiment, the two possible outcomes are labeled as “\_\_\_\_\_” and “\_\_\_\_\_.”
- The probability of at least 3 successes in a binomial experiment is an example of \_\_\_\_\_ probability.
- True or False: In a binomial experiment, the probability of getting a success must be the same for every trial.
- True or False: The phrases “Greater than” and “Does not exceed” mean the same thing.

 PRACTICE

5. Counting the number of broken lightbulbs in a case of lightbulbs.
6. Surveying whether restaurant customers prefer mild, medium, or hot salsa on their tacos.
7. Surveying whether customers at a local ice cream shop prefer their ice cream served in a cup or a cone.
8. Counting the number of male and female lions out of the six lions at a local zoo.
9. Randomly selecting five theater majors to participate in an upcoming play from a group of 40 students comprised of theater majors and non-theater majors.
10. Asking a class of 32 students whether they would prefer the final exam to be free answer or multiple choice.
11. Asking the employees of a small business whether they'd prefer a catered lunch of tacos, pizza, or neither.
12. Asking each audience member in a theater whether they enjoyed the movie they just watched or not.
13. Determining the number of pickles in each jar of a case of 16 jars of pickles.
14. Asking the 140 guests at a wedding whether they would prefer chicken or steak for their dinner entree.
15. Counting the number of true questions on a 20-question true-or-false test.
16. Tracking whether patients entering the ER during an afternoon are having chest pain or not.

 APPLICATIONS

Calculate the binomial probability. Round your answer to the nearest ten-thousandth, if necessary.

17. What is the probability of getting exactly 4 heads in 8 coin tosses?
18. When rolling a standard 6-sided die 9 times, what is the probability of the die landing on an even number exactly 2 times.
19. A spinner for a board game has 10 wedges, 4 of which are blue while the other wedges are red. What is the probability of the spinner landing of red exactly 4 times if it is spun 5 times.

20. A spinner at a carnival has 8 wedges. Landing on one specific wedge wins a prize while landing on any of the other wedges does not win a prize. If the spinner is spun 5 times, what is the probability that exactly zero prizes are won.
21. Data collected from parents indicates that 12% of children attending a summer camp are allergic to bees. If 10 children are stung by bees during the summer camp, what is the probability that exactly 8 of the children are not allergic to bees.
22. Data pulled from the 72 resumes for a data entry position indicates that 75% of applicants have previous experience for the job. If 6 resumes are pulled at random for the first round of interviews, what is the probability that exactly 4 of the candidates have previous experience?
23. According to a survey of 75 dentists, 84% recommend that their patients with gum inflammation use a pH-balanced mouthwash. If 5 of these dentists are asked at random, what is the probability that exactly 2 of them recommend a pH-balanced mouthwash?
24. Tea Leaves magazine surveyed its readers and discovered that 62% of them prefer milk in their tea instead of sugar. If 20 readers were surveyed at random, what is the probability that exactly 12 of them would prefer milk in their tea?
25. The manager of a bookstore discovers that 16% of customers enjoy sitting in the bookstore café to read. What is the probability that exactly 9 out of 10 randomly selected customers do not enjoy sitting in the bookstore café to read?
26. Human resources learns that 54% of all workplace accidents happen during third shift. If 9 accidents are reported in one week, what is the probability that 4 of them did not happen during third shift?
27. The local hospital's data indicate that 52.5% of newborn babies are boys. What is the probability that of the next 7 newborn babies, less than 3 will be boys?
28. The probability of certain flower seeds sprouting is estimated to be 86%. If 20 seeds are sowed, what is the probability that no more than 3 will not sprout?
29. Suppose that 60% of tickets for a certain lottery win a prize and the remaining 40% do not win anything. If Carol buys twenty lottery tickets, what is the probability that the number of winning tickets will not exceed ten?
30. It is believed that about 10% of people in the world have blue eyes. What is the probability that out of 30 randomly chosen people, at most 5 will have blue eyes?
31. About 7% of people in the world use Spanish as their native language. If 50 random people are selected, what is the probability that fewer than seven of them are Spanish native speakers?

32. Suppose that 1% of juice cans come underfilled from the filling machine. What is the probability that in a batch of 100 juice cans, no more than two will be underfilled?
33. Heating is one of the ways to improve the quality of a natural gem. The gem is put into a high-temperature flame for a specific time and then allowed to cool slowly. This process can enhance the color of the gem and remove the inclusions. If we assume that about 3% of the gems get significantly better color and clarity after the heat treatment, what is the probability that of 10 gemstones, at least 2 will become significantly better?
34. If an archer has an 80% chance to hit the target, what is the probability that he will hit it at least 8 times in 10 tries?
35. A machine includes a set of 8 identical nodes, and it can continue working while at least 6 nodes are functioning correctly. If the probability of each node failing at any particular moment is 0.6%, what is the probability that the machine will stop working?
36. As a part of an advertising campaign, each chocolate bar of a particular company comes with a sticker hidden inside. Jacob wants to collect all 15 different stickers, and now he is missing only one. If the chance of getting each sticker is the same and Jacob buys five chocolate bars, what is the probability that he will find more than one copy of the missing sticker?
37. Suppose eight cards are drawn with replacement from a standard deck of cards. What is the probability that the number of red cards drawn is no less than six?
38. Nine fair six-sided dice are thrown. What is the probability of getting a 1 on more than two dice?
39. The probability of winning when placing a bet on a single color (either red or black) in a game of roulette is  $\frac{18}{38}$ . What is the probability of winning more than half of such bets in 20 roulette games?
40. A recent survey showed that about 9% of adult people in the US do not have a car in the household. If 40 adult US people are chosen at random, what is the probability that a minimum of six of them do not have a car?
41. Suppose that 12% of people in a certain population suffer from migraines. If 40 people are selected at random from this population, what is the probability that at least 5 of them suffer from migraines?
42. In a recent survey conducted among young adults, about a quarter of respondents stated that they are indifferent toward the political life of their country. If a group of 30 young adults is selected at random, what is the probability that the number of people indifferent to politics will be greater than or equal to 7?
43. About 45% of the US population have blood type O. What is the probability that at least 10 out of 20 randomly selected US people have blood type O?

44. According to the 2019 National Survey on Drug Use and Health, about 55% of US adults aged 26 or older drank alcohol in the latest month. If 25 US adults are chosen at random, what is the probability that at least 15 of them have consumed alcohol in the latest month?
45. There are three major colors of Labrador Retrievers: black, brown, and yellow. The individual color depends on the combination of several specific genes. When two black Labradors with a particular genetic code are mated together, there is about a 25% chance for each of their puppies to have a yellow coat. If there are 7 puppies in a litter of two such black Labradors, what is the probability that more than 3 of them are yellow?
46. In a certain survey, 26% of adult respondents indicated that they did not have any physical activity during the week preceding the survey. If 15 adult people are randomly selected from the population being surveyed, what is the probability that at least 10 of them have exercised in the past week?





## 10.5 PROJECT

### AMERICA'S THIRD FAVORITE PET: CAN WE PREDICT THEIR FUR COLOR?

According to the Humane Society of the United States, rabbits are the third most popular type of mammal owned as pets, with cats and dogs ranking higher. In this activity, you will calculate the probability of seeing a particular fur color when breeding rabbits.

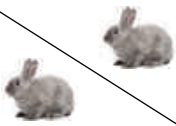
Suppose that a particular breed of rabbit can be one of two colors: gray or white. The color of this breed of rabbit is determined by whether it has at least one dominant allele  $G$  in its genotype or whether it has only the recessive allele  $g$ . Out of the three possible genotypes ( $GG$ ,  $Gg$ , and  $gg$ ), rabbits with genotypes  $GG$  and  $Gg$  exhibit gray fur while rabbits with genotype  $gg$  exhibit white fur. Assume that each parent passes on one of its two color alleles to each offspring with equal probability.

If we breed two gray rabbits of genotype  $Gg$ , the possibilities for the fur color of the offspring are given in the following table.

	$G$	$g$
$G$	$GG$ 	$Gg$ 
$g$	$Gg$ 	$gg$ 

## 10.6 Exercises

### ✓ CONCEPT CHECK

1. A random variable's numeric value is determined by the outcome of a \_\_\_\_\_.
2. Expected value is a \_\_\_\_\_ average.
3. True or False: In the scenario where you win \$1 if a fair six-sided die lands on a 1, \$2 if it lands on a 2, and so on, the expected value must be an integer 1 through 6.
4. True or False: The expected value of a game is the average of the maximum and minimum outcomes.

### 💡 PRACTICE

Calculate the expected value of each scenario. Round your answer to the nearest hundredth, if necessary.

5.

$x_i$	$P(x_i)$
1	0.21
2	0.58
3	0.06
4	0.15
5	0.0

6.

$x_i$	$P(x_i)$
-\$1.50	0.3
\$0.00	0.5
\$2.75	0.1
\$5.00	0.1

7.

$x_i$	$P(x_i)$
25	$\frac{1}{3}$
15	$\frac{2}{5}$
10	$\frac{1}{15}$
5	$\frac{1}{5}$

8.

$x_i$	$P(x_i)$
1	0.12
2	0.09
3	0.33
4	0.14
5	0.04
6	0.28

9.

$x_i$	$P(x_i)$
\$2.25	0.1
-\$1.43	0.2
\$4.67	0.3
\$3.11	0.3
\$0.56	0.1

10.

$x_i$	$P(x_i)$
10	$\frac{4}{21}$
5	$\frac{1}{7}$
35	$\frac{1}{6}$
15	$\frac{3}{10}$
20	$\frac{1}{5}$

11. The number of even numbers showing when a pair of standard six-sided dice are rolled.

$x_i$	$P(x_i)$
0	$\frac{9}{36} = \frac{1}{4} = 0.25$
1	$\frac{18}{36} = \frac{1}{2} = 0.5$
2	$\frac{9}{36} = \frac{1}{4} = 0.25$

12. The number of odd numbers showing when three standard six-sided dice are rolled.

$x_i$	$P(x_i)$
0	0.125
1	0.375
2	0.375
3	0.125

 APPLICATIONS

13. Alex wanted to learn how to play guitar, so his father bought him an inexpensive model for training. The number of strings  $x_i$  that will require a replacement within a year is distributed as follows.

$x_i$	$P(x_i)$
0	0.262
1	0.393
2	0.246
3	0.082
4	0.015
5	0.002
6	0

Find the average number of strings to be replaced in a year.

14. A shooter fires at 5 targets. The number of hits  $x_i$  is distributed as follows.

$x_i$	$P(x_i)$
0	0.01
1	0.08
2	0.23
3	0.34
4	0.26
5	0.08

Find the average number of targets the shooter will hit.

15. An insurance policy for a car costs \$1500 per year. According to the past data, the probability of having a minor accident during a year is 0.2, and the average amount of insurance claim is \$5000. The probability of having a serious accident is 0.01, and the average claim is \$30,000.
- Find the average amount of the insurance claim.
  - Find the average income of an insurance company from the sale of one policy.
16. A horse in a circus is trained to jump over obstacles. It will jump over one obstacle with a probability of 60%, over two obstacles with a probability of 30%, and over three obstacles with a probability of 10%. Find the expected number of obstacles that the horse will jump over.
17. A student bought a second-hand laptop. During the first year of its usage, he will have to spend \$100 on repairs with the probability of 0.45 and \$200 with the probability of 0.35. Find the average amount the student will have to spend on repairs in the first year.

18. Suppose that there is a 60% chance that Michael will go to the gym twice a week, a 35% chance that he will go once, and the remaining 5% that he will not go to the gym.
- What is the expected value for the number of times Michael goes to the gym in a week?
  - Assuming there are 4 weeks in a month, what is the average number of times Michael goes to the gym in a month?
19. A coffee shop analyzed the sales for the latest month and got the following data. 55% of customers spent about \$5, 25% spent about \$9, and the remaining 20% spent about \$11.
- What is the expected amount that a customer will spend?
  - If the average number of customers per day is 80, what is the average daily revenue of the coffee shop?
20. A device consists of four independently operating nodes. The probability that exactly one node will fail in an experiment is 0.3. The probability of two nodes failing at once is 0.05. The probability of three nodes failing simultaneously is 0.03. The probability of all four nodes failing at the same time is negligible.
- Find the expected number of failing nodes in the experiment.
  - If a similar test is performed simultaneously on three devices, what is the expected number of failing nodes?
21. A large entrepreneur plans to invest in a certain project. According to forecasts, the profit from the project will be \$20,000 with a probability of 0.5, \$30,000 with a probability of 0.2, or \$25,000 with a probability of 0.3. What is the expected profit on this investment?
22. Suppose Piper eats out twice a week 15% of the time, she eats out once a week 35% of the time, and she doesn't eat out anytime during the week 50% of the time. What is the expected value for the number of times Piper eats out during a week?
23. Suppose that you and a friend are playing cards and decide to make a bet. If you draw two aces in succession from a standard deck of cards without replacing the first card, you win \$50.00. Otherwise, you pay your friend \$10.00.
- What is the expected value of your bet?
  - If the same bet was made 25 times, how much would you expect to win or lose?
24. A European roulette wheel has only one green slot instead of two. Using Example 2 from this section as a guide, calculate the expected winnings on a European roulette wheel if a player bets \$1.00 on red to play the game.

25. Jim likes to day-trade on the Internet. On a good day, he averages a \$1100 gain. On a bad day, he averages a \$900 loss. Suppose that he has good days 25% of the time, bad days 35% of the time, and the rest of the time he breaks even.
- What is the expected value for one day of Jim's day-trading hobby?
  - If Jim day-trades every weekday for three weeks, how much money should he expect to win or lose?
26. A university in town is raffling off \$20,000 for student scholarships. You can buy one ticket for \$10, three tickets for \$25, or five tickets for \$40. Assume that the university sells 10,000 tickets.
- Find the expected value for each of the three ticket options: purchasing just one ticket, purchasing three tickets, or purchasing five tickets.
  - Should you buy one, three, or five tickets in order to maximize the money you expect to have at the end of the raffle?
27. You need to borrow money from your sister. She's feeling quirky on the day you ask and says she wants you to flip a coin. Heads, you get \$15, tails you get \$5. Thinking this is weird, you ask your mother for money instead. She says she'll let you roll a die and she'll give you \$2 times the number that appears on the die. Before agreeing to either of these unique offers from the "mathy" folk in your family, you decide to see which is the better offer by calculating the expected value for each method (realizing that you too fit the bill of a "mathy" member of your family). Which offer should you take? Explain your reasoning.
28. Assume that stock in Degree Compass, a predictive analytics company in higher education, returns the percentages shown in the table.

Degree Compass Stock Returns	
Annual Return Rate	Probability
15%	0.17
30%	0.51
45%	0.32

Calculate the expected value of the return rate for stock in Degree Compass.

29. During the NCAA basketball tournament season, affectionately called *March Madness*, part of one team's strategy is to always foul their opponent's tall forward. Because he is so tall, he makes 57% of shots he takes close to the basket. However, when he is fouled, his free-throw shooting percentage is only 51.5%. The shots he makes close to the basket are worth two points and each of the two free throw shots after being fouled are worth one point.
- Calculate the expected value of the number of points the forward makes when he takes a shot close to the basket.
  - Calculate the expected value of the number of points the forward makes when he shoots two foul shots.
  - Based on these expected values, is fouling the tall forward a good strategy? Explain your answer.

30. On your next multiple-choice test, each question has four incorrect answers and one correct answer to choose from. Your professor tells you that each correct answer you make, you receive 1 point, but you lose  $\frac{1}{4}$  point for each incorrect answer.
- What is your expected gain or loss on a question if you have no idea of the correct answer and end up simply guessing?
  - What is your expected gain or loss if you guess on all 25 questions?

## 10.6 PROJECT

### EXPECTED VALUE AND INSURANCE PREMIUMS

When you purchase a homeowners insurance policy, you pay a certain amount of money (the premium) to the insurance company. If nothing happens to your home, the insurance company keeps the money. If you make a claim, the company will pay to fix your home, usually spending a lot more than what your premium was. Due to this set up, the insurance company makes money on some policies and loses money on others.

In this activity, we will investigate the way an insurance company computes insurance premiums.

Suppose that in a certain neighborhood, an insurance company has used historical data to determine that the probability of a house fire occurring at a home over the course of one year is 0.02%.

- What is the probability that there will not be a fire at a house in the neighborhood over the course of one year?

Assume that the insurance company charges a \$300 annual premium for fire insurance. If there is a fire, the insurance company will pay out \$200,000 to the homeowner.

- Fill in the table below. What happens when there is no fire? Explain why this is.

Probability and Payout for Insurance Company		
Event	Probability	Payout – Premium
Fire		
No Fire		

- Determine the expected value that the insurance company will pay out.
- What does the expected value say about the average loss or gain for the insurance company on each policy they sell?
- How much would the insurance company expect to earn on average if it sold 10,000 policies in a year?

# 11.1 Exercises

## ✓ CONCEPT CHECK

1. Data are the \_\_\_\_\_, \_\_\_\_\_, or \_\_\_\_\_ gathered about a specific variable in a population.
2. During a census, data is obtained from \_\_\_\_\_ of the population being studied.
3. When a study has \_\_\_\_\_, it favors a certain outcome.
4. Stratified sampling is also referred to as \_\_\_\_\_ sampling.

## 🔗 APPLICATIONS

5. A study was taken to determine whether insulin level influences the course of polycystic ovary syndrome (PCOS). A group of women with PCOS was selected, and half of them were treated with metformin (a drug commonly used to treat diabetes) while the other half was in a control group. Researchers compared the symptoms of PCOS in the two groups. Identify the population of interest and the variables in this study.
6. Lactobacillus is very important for human health, specifically gut health. A group of researchers decided to study how the amount of sugar in a diet could affect the activity of lactobacillus in the gut. They selected a group of people who did not suffer from any gut diseases and divided them into three subgroups. The first subgroup got a diet with high sugar content, the second got a diet with low sugar content, and the third did not change their diet. Identify the population of interest and the variables in this study.
7. An experiment was designed to study the influence of noise level on people's stress level. Several volunteers of differing ages and social groups were subjected to noises of various types and intensities. During the study, researchers measured participants' level of cortisol, which is a hormone that is produced in response to stress. Identify the population of interest and the variables in this study.
8. Social research was conducted to determine if there is a correlation between annual income and the number of children in families. Researchers surveyed two-parent households where both parents were from 25- to 40-years old. Identify the population of interest and the variables in this study.

Decide if each numerical value from a statistical study is a population parameter or sample statistic.

9. After the presentation by the United Way representative, 67 of the night's 300+ attendees were interviewed about their reaction. Of the 67 people interviewed, 79% said they were motivated to donate more of their time and/or money to helping nonprofit organizations.

10. The Nashville Country Music Marathon reported an average finish time of 4:46:28 for the 4082 finishers.
11. A medical study showed that the heart-rate profile during exercise and recovery is a predictor of sudden death. Of the 5713 men studied, the mean maximum heart rate (expressed as the percentage of the predicted maximum heart rate) during exercise was found to be 96% in subjects who died suddenly from cardiac causes during the 23 years when the follow-up was conducted.<sup>2</sup>
12. An estimated 65% of drivers in rural or town areas view traffic conditions in a good light versus 39% of drivers in the city or suburbs based on a recent news report that aired nationally.

In each scenario, identify the population, the sample, and any population parameters or sample statistics that are given.

13. A medical study followed 675 cancer patients who received either the new drug *Lafent* or a standard chemotherapy drug. 76% of those who received *Lafent* were still living after eight months, compared to only 63% of those who received the standard chemotherapy drug.
14. US realtors across the country are encouraged by the latest reports on the real estate market. Taking into account seasonal factors, sales rose by nearly 9% in the West, 3.5% in the South, 3.4% in the Northeast, and 1% in the Midwest.
15. The online version of *Health* magazine, Health.com, reported the following: “Data from the Women’s Health Study . . . examined the medical records of more than 36,000 women who had no history of depression at the start of the study. Roughly 18% of the women were experiencing some form of migraine or had suffered from the headaches in the past. Over the next 14 years, 11% of the study participants received a depression diagnosis.” One of the conclusions of the study was that middle-aged women who experience migraines are 40% more likely to become depressed.<sup>3</sup>
16. In a recent study, US graduates of for-profit higher education institutions were between 4.8 and 6.7 percentage points more likely to be unemployed than those at nonprofit institutions and community colleges.<sup>4</sup>

2 Xavier Jouven et al., “Heart-Rate Profile during Exercise as a Predictor of Sudden Death.”

3 Matt McMillen, *Health*, <http://www.health.com>

4 Dan Berrett, *The Chronicle of Higher Education*, <http://www.chronicle.com>

17. Java Express is a company that sells high-end coffee appliances and gourmet coffee. Due to the current economic conditions, the company is looking into ways to change its strategy in order to appeal to more frugal consumers.

Before investing in costly setup expenses, Java Express needs to know the percentage of coffee consumers who would buy from a new line of less expensive products. To estimate this percentage, the company chooses 5 of its largest markets and surveys every registered customer from each of these chosen markets. A total of 6195 customers complete the survey.

The results show that 45% of those surveyed are very interested in the new line of products, 32% are somewhat interested, and the remaining 23% are not interested in the new products at all. Based on these results, the researchers estimate that approximately 77% of coffee consumers will be receptive to the new line of products. Java Express decides that it is worthwhile to introduce a new line of less expensive products to the market.

18. A study was conducted to investigate whether or not exercise is a factor in the overall outlook and positive spirit of Americans.

For the study, 400 Americans were selected at random from each of the following two categories: those who exercise on a regular basis and those who do not. For the purpose of the study, regular exercise was defined to be light to moderate activity at least three times per week. A total of 800 Americans completed the brief telephone survey. Of those who exercise regularly, 74% said that their overall outlook on life is positive. Of those who do not exercise regularly, 68% said that their overall outlook on life is positive.

Though not a definitive study, the researchers concluded that exercise does appear to influence the attitudes of Americans. In addition, the researchers estimated that approximately 71% of all Americans have a positive outlook. Further research would likely be conducted on the subject at a later time.

**Determine which type of study should be conducted: an observational study or an experiment.**

19. A football coach wants to know the average weight of his offensive linemen.
20. A doctor wants to study the effect of ginseng on patients' memories.
21. A city planner wants to know the average number of vehicles parked in downtown parking lots on any given business day.
22. A cell phone company wants to know the average total length of time teenagers spend on the phone each day.
23. A dentist wants to look at the effects of a new dental material used for fillings.
24. A financial institution wants to know if customer behavior will change significantly when interacting with a new mobile app feature.

Identify the sampling technique used in each scenario.

25. To ensure the quality of its product, a company tests every 15th item off the assembly line.
26. A student committee in the biology department was formed by randomly choosing three biology majors from every level of student, that is, 1st year, 2nd year, etc.
27. In order to choose the winners of free tickets to the campus concert, student housing printed out all 60 pages of student ID's and then chose three of the pages randomly.
28. A candidate for the local school board surveyed parents picking up their children from the public school on three school days in the last month.
29. Surveying movie goers as they exited the late movie, researchers determined that only young adults under the age of 22 see movies in the theater anymore.
30. In order to sample the production yield of milk from the farm's herd of cows, random samples are taken from each of the five different types of cows.
31. Using Excel to generate an arbitrary list of customers, the marketing department sent promotional materials to the top 250 names on the list.

Determine an appropriate sampling method for each scenario. Give your reasons for choosing the method. Describe any potential biases that the researcher might need to consider.

32. A state senator wishes to survey his constituents on issues in the upcoming legislature session.
33. A pharmaceutical company wishing to test the outcomes of a new drug for a particular skin disease finds 1200 patients willing to participate in the study. They can only choose 100 of them for the actual study.
34. Medical scientists wish to evaluate the effects of vitamin E and low-dose aspirin in primary prevention of cardiovascular disease and cancer in apparently healthy women.
35. Researchers wish to study the effects of watching too much television at a young age for children diagnosed with autism.

- 36.** A pharmaceutical company claims their new antacid has fewer side effects than the leading drug and is more effective in relieving the pain of occasional heartburn in patients with reflux disease. To prove this claim, the company conducted a clinical trial on 50 patients with reflux disease. Half of them got the new antacid, and the other half got the leading drug. After a predetermined period of time, the patients were surveyed on their experience. The researchers, unlike the patients, knew what drug each patient was taking.
- Identify the explanatory and response variables.
  - Identify the treatment in the experiment.
  - Determine which group is the treatment group and which group is the control group.
  - State whether the experiment is a single-blind or double-blind study. Do you think this is the best choice for this study?
- 37.** A study was conducted to prove that a new virus-suppressing drug was more effective than the conventional antiviral agent. Patients susceptible to viral infection were randomized into two groups. Participants in Group A were given the new virus-suppressing drug and Participants in Group B were given the conventional antiviral agent. The patients were not informed which drug they were taking, but the researchers were. A viral load was calculated by estimating the number of viral particles per milliliter of blood plasma. The viral load was measured before and three weeks after the course of treatment.
- Identify the explanatory and response variables.
  - Identify the treatment in the experiment.
  - Determine which group is the treatment group and which group is the control group.
  - State whether the experiment is a single-blind or double-blind study. Do you think this is the best choice for this study?
- 38.** A clinical trial was aimed at studying a drug for chronic progressive degenerative disease. Researchers expected the drug to slow down or even reverse the disease's degenerative processes. A group of people with this disease was selected, and some of them were injected with the drug while some were given a placebo in the form of saline. Neither the subjects nor the researchers knew who was receiving the drug and who was receiving the placebo. Before, during, and after the trial, patients underwent various tests to identify and evaluate degenerative processes.
- Identify the explanatory and response variables.
  - Identify the treatment in the experiment.
  - Determine which group is the treatment group and which group is the control group.
  - State whether the experiment is a single-blind or double-blind study. Do you think this is the best choice for this study?

39. To test the hypothesis that vitamin C increases the absorption of iron, researchers recruited a group of people with iron deficiency. Some of the people were prescribed iron supplements, and the others were given iron with vitamin C. Both the researchers and the subjects knew what they were taking. After a month of taking the drugs, the patients' iron levels were remeasured.
- Identify the explanatory and response variables.
  - Identify the treatment in the experiment.
  - Determine which group is the treatment group and which group is the control group.
  - State whether the experiment is a single-blind or double-blind study. Do you think this is the best choice for this study?
40. *Self-selected* samples are a type of convenience sampling in which the participants volunteer to participate in the study rather than being chosen by the researcher. One issue with this type of sampling is that people who “self-select” to be in a survey often either have very strong opinions about an issue or desire monetary rewards for their participation. For instance, consider online polls regarding political views that are conducted by popular news outlets. Describe some of the potential responses from those who take the time to log on and respond. Is it reasonable to generalize the results from a study like this to include all of the American public? Why?
41. Often words like “best” and “worst” are used in reporting data. However, descriptive words like these are hard to measure in a concrete way. Consider how you could measure small towns to compile a list of “America’s 50 Best Small Towns to Live In.” Name at least five distinct measurements.
42. Researchers try to eliminate as many biases in studies as they can in order to get a true picture of the population they are studying. Describe as many potential sources of bias as you can if you were asked to study the effects of alcohol on college campuses.

 **WRITING & THINKING**

43. Explain how cluster sampling is different from stratified sampling.

**Solution**

- a. Although the graph was on the United States Census website with relative source information noted, the graphic could be improved. The bold subtitle stating that the government receives a total of \$24.9 billion dollars in revenue can be misleading for the data bars that are shown. The bars don't actually represent the entirety of that money. They only show the top 13 states, which represent a total of 76.4% of the revenue. A horizontal axis with markings might also help readers.
- b. We are told that the graphs are included in the text, along with the data they represent. However, since the graphs are displayed side-by-side, having consistency with the horizontal labels as well as the type of graph would be an improvement. Notice that dates are given in the first two graphs while presidents' names are given in the third graph. It's also worth noting that 21.0% in the first graph is visually higher than 21.1% in the last graph.

**Skill Check Answers**

1. Mailboxes, fencing, and buildings were all tied for the smallest number of crashes at 5 each. 2. Lower class limit of the 4th class: 280; Upper class limit of the 4th class: 329  
3. Corequisite

## 11.2 Exercises

**✓ CONCEPT CHECK**

- A \_\_\_\_\_ is a table that displays how often each value in the data set occurs.
- A \_\_\_\_\_ is a circular graph that illustrates the size of each category in relation to the whole data set.
- In a \_\_\_\_\_, the height of each bar represents the frequency of each class.
- True or False: The class width is equal to the lower class limit minus the upper class limit.
- True or False: The width of the bars in a bar graph should be equal in size.

**💡 PRACTICE**

6. The grades on the first statistics test for Ms. Seago's class are listed in the following table. Construct a frequency distribution for the grades.

**Grades on Statistics Test 1**

A	C	F	C	C	D	F
B	D	F	B	A	A	F
B	C	C	A	B	F	D

7. Sisscon is a phone answering service. The following data are the numbers of calls per day reported by the company for the last month.

10	72	64	32	78	62	11
37	45	32	52	38	70	66
13	21	14	13	39	73	62
41	63	44	23	27	22	21
55	24	53	43	20	16	22

- Create a grouped frequency distribution for the data using 8 classes and then use it to answer the following questions. Let the first lower class limit be 0 and the class width equal 10.
- Calculate the relative frequencies for each class. Give your answer as a percentage rounded to the nearest tenth.
- For what percentage of the days is the number of calls between 40 and 49?
- For what percentage of the days is the number of calls in the single digits?
- What is the most common range for the number of calls per day?

Create a frequency distribution with the indicated number of classes for each set of data. Include the frequency and relative frequency of each class.

8. The following data represent the numbers of curl-ups completed in 60 seconds for a group of 16 eight-year-old children. Use six classes that have a class width of 5. Begin with a lower class limit of 15.

31	34	41	36	27	29	18	33
31	28	34	22	26	28	36	42

9. The following data represent the caloric intakes in one day for a group of 15 people between the ages of 20 and 39. Use five classes that have a class width of 400. Begin with a lower class limit of 1800.

2700	2200	2500	2800	2600
3000	2600	2200	3100	2800
1800	3500	2500	3000	2900

 APPLICATIONS

10. A local book shop analyzed their sales to determine the most popular genres. The following table shows data collected on the number of books of each genre sold in the latest quarter. Answer the following questions based on the table.

Grades on Statistics Test 1 Book Genre Number of Items Sold (% of total)	
Romance	327 (25.85)
Detective and Mystery	189 (14.94)
Fantasy	153 (12.09)
Action and Adventure	128 (10.12)
Science Fiction	96 (7.59)
Suspense and Thrillers	91 (7.19)
Classics	77 (6.09)
Comic Book or Graphic Novel	75 (5.93)
Short Stories	62 (4.90)
Poetry	24 (1.90)
Other	43 (3.40)

- What do the numbers in the parentheses represent?
  - Which genre was sold the most?
  - How many books were sold by the shop in the last quarter?
11. Sofie keeps track of her expenses to make budget planning more transparent and understandable. The following table shows her expenses in each category for the last month.

Category	Amount Spent (% of total)
Housing and Utilities	\$752.08 (25.53)
Tax and Insurance	\$544.76 (18.49)
Food	\$406.33 (13.79)
Household Expenses	\$327.12 (11.10)
Wellness and Beauty	\$217.64 (7.39)
Transport	\$184.09 (6.25)
Entertainment	\$174.85 (5.93)
Clothes and Accessories	\$108.25 (3.67)
Other	\$231.18 (7.85)

- What do the numbers in the parentheses represent?
- Which category required the most spending?
- What are Sophie's total expenses for the last month?

12. The following table gives the grouped frequency distribution of weights of 194 babies in kilograms. Answer the questions that follow based on the distribution.

**Weights of Babies**

Birth Weight (kg)	0.00–0.99	1.00–1.99	2.00–2.99	3.00–3.99	4.00–4.99	5.00–5.99
Frequency	2	17	39	89	46	1

- How many classes are in the grouped frequency distribution?
  - What is the class width?
  - What is the value of the lower class limit of the 3rd class?
  - What is the value of the upper class limit of the 5th class?
  - What is the relative frequency of the 4th class? Give your answer as a percentage rounded to the nearest tenth.
13. The following table represents a grouped frequency distribution of the number of hours spent on the computer per week for 55 students.

Hours	Number of Students
0.0–4.4	9
4.5–8.9	14
9.0–13.4	21
13.5–17.9	11

- Calculate the relative frequencies (as percentages rounded to the nearest tenth) for each class.
  - What percentage of the students used the computer between 9 and 13.4 hours per week?
  - What percentage of the students used the computer less than 9 hours per week?
14. The following pie chart shows destinations of recent University of Kent mathematics graduates, including business, financial math, and statistics.<sup>11</sup>

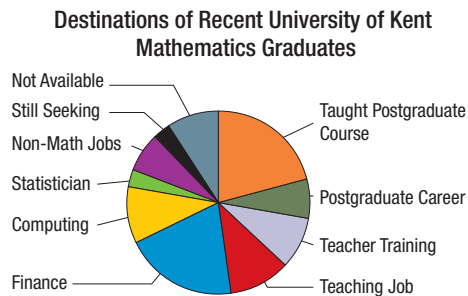

- Does it appear that any destination category accounts for more than 25% of the graduates?
- Which pairs of destinations appear to have similar percentages of graduates?
- How many mathematics graduates from the University of Kent were surveyed?
- Is the graph misleading in any way?

15. The following pie chart shows Apple’s quarterly revenue<sup>12</sup> by category for the fiscal second quarter of 2021. Use the chart to answer the following questions.

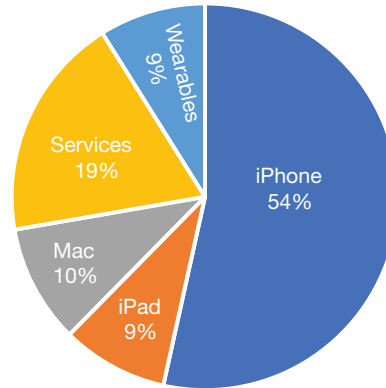

- What product generated the most revenue?
- What percentage of the sales were services?
- What percentage of sales came from Mac, iPad, and Wearables?
- Is the statement “Most revenue was generated from Mac, iPad, and Wearables” true? Explain.

16. Consider the bar graph of the predicted fastest growing occupations between 2010 and 2020.<sup>13</sup>

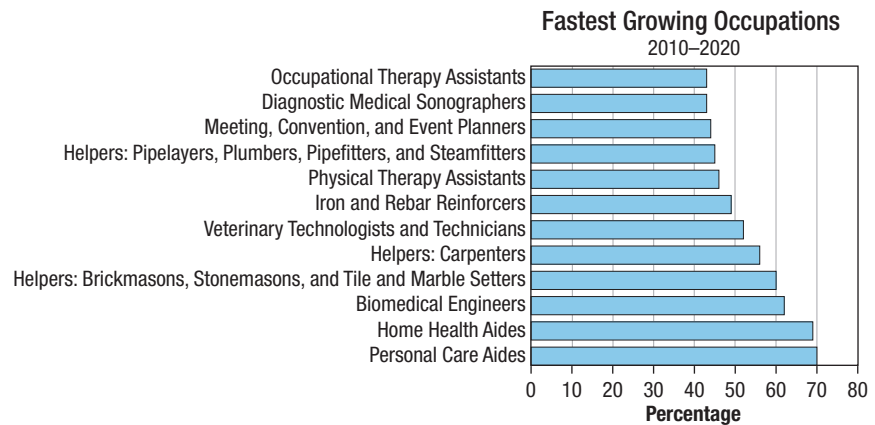

- At a quick glance, which occupation is predicted to grow the most between 2010 and 2020? What is the predicted amount of growth?
- How many new jobs will be available in the fastest-growing occupation in 2020?

12 “Investor Updates,” News and Results, Apple, accessed January 4, 2022, <https://investor.apple.com/investor-relations/default.aspx>.

13 BLS Occupational Outlook Handbook, <http://www.bls.gov/ooh>

17. The stacked bar graph shows the average number of hours that married people in Japan spend each day doing various activities.<sup>14</sup>

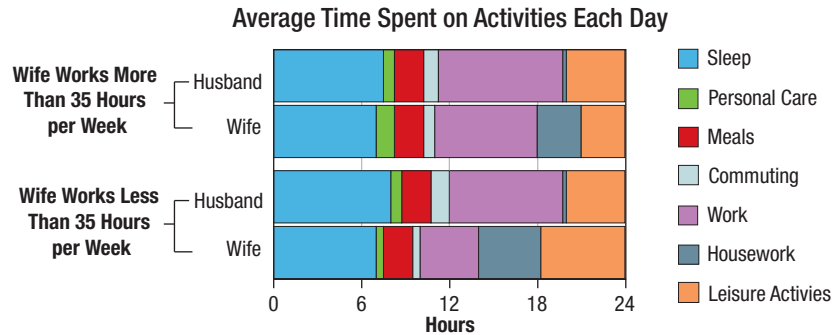

- For wives who spend less than 35 hours per week working, how many hours on average are spent each day for leisure activities?
- For husbands whose wives work more than 35 hours per week, approximately how many hours on average are spent on sleep?
- Compare the number of hours spent sleeping for wives in each category.
- What type of graph could be used to represent these data in a clearer fashion?

18. The following histogram displays data of wait times for delivery from a local sushi restaurant.

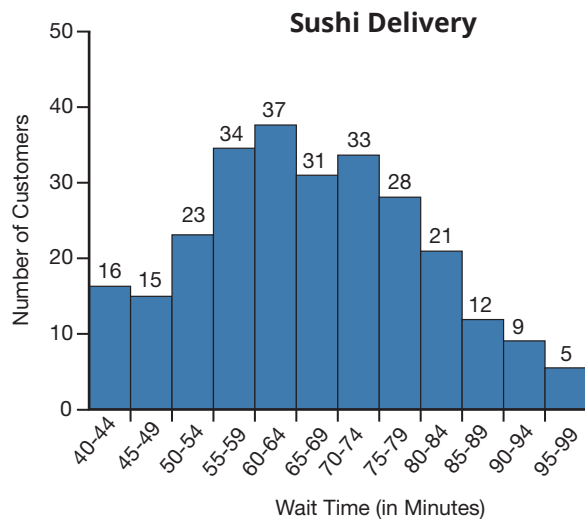

- Determine how many wait times were recorded in the survey.
- How many customers had to wait between 60 minutes and 74 minutes?
- Approximately what percentage of customers had to wait at least one hour?
- What was the most common wait time for customers?
- The middle bars represent 65–69 minutes and 70–74 minutes. Is it accurate to say that about half of the wait times were more than 70 minutes? Why or why not?

<sup>14</sup> Statistics Bureau (Japan), <http://www.stat.go.jp>

19. The following histogram displays data on the number of words in essays written by students at a high school.

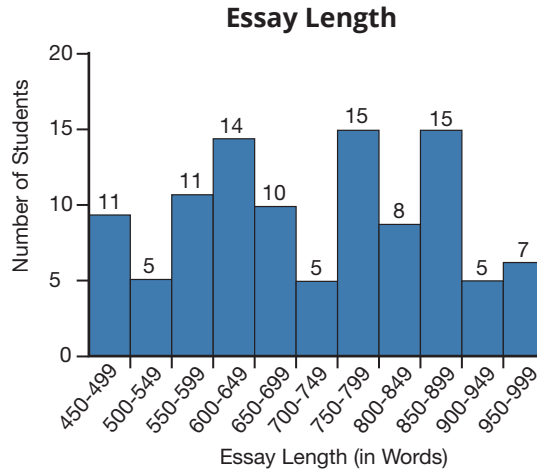

- Determine how many essays were surveyed.
- How many essays had the number of words between 700 and 899?
- Approximately what percentage of essays had at least 800 words?
- What was the most common numbers of words in essays?
- The middle bar represents 700–749 words. Is it accurate to say that about half of the essays had 700 or more words? Why or why not?

20. The following graph shows the US unemployment rate from February 2011 to February 2013.<sup>15</sup>

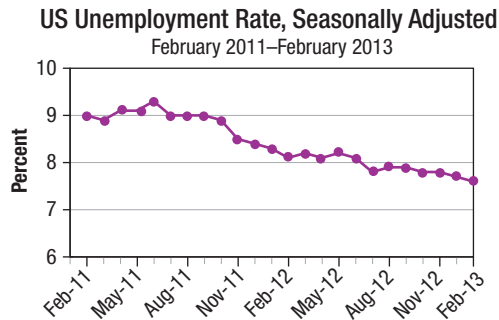

- Describe the trend of the unemployment percentage from February 2011 to February 2013.
- Approximate the month and rate of the highest unemployment during this time period.
- Approximate the month and rate of the lowest unemployment during this time period.
- Is the graph misleading in any way?

<sup>15</sup> Bureau of Labor Statistics, <http://www.bls.gov>

21. An online learning platform presented their analytics on average daily usage by their users. The data for June 2021 is shown in the following graph. Use the graph to answer the following questions.

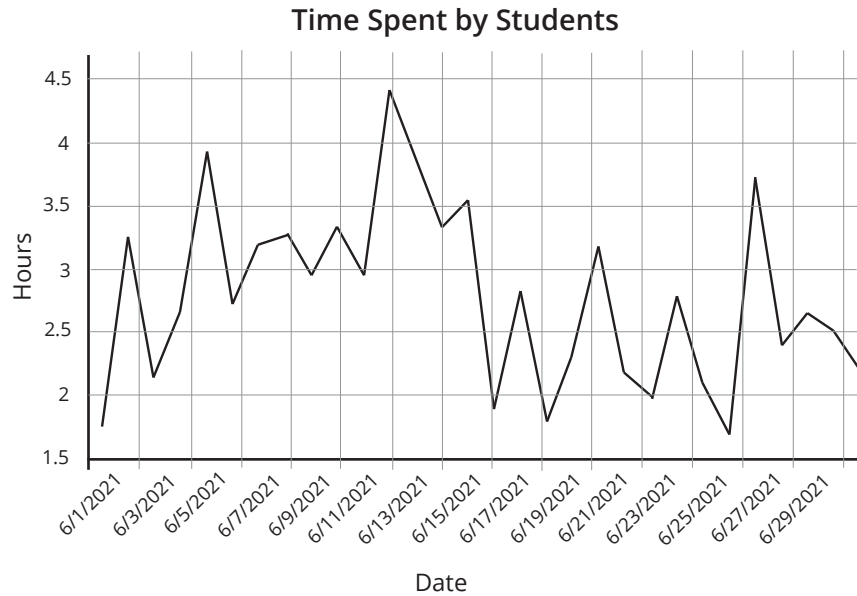

- a. Approximately when did the amount of time spent by students on the learning platform peak during this period?
- b. Suppose you are writing an article about the usage of this platform and referencing this graph. Would the headline “Learning Engagement is Falling” be a fair representation of the information contained in this graph?

22. Answer the following questions about the Job Growth graph.<sup>16</sup>

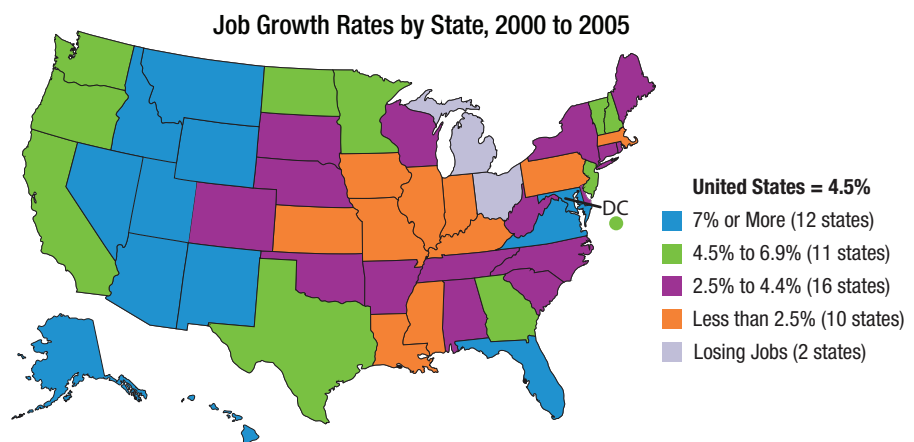

- a. How many states lost jobs between 2000 and 2005?
- b. In what part of the country are jobs growing the most in this time period?

<sup>16</sup> InContext, <http://www.incontext.indiana.edu>

23. What errors occur in the following histogram?

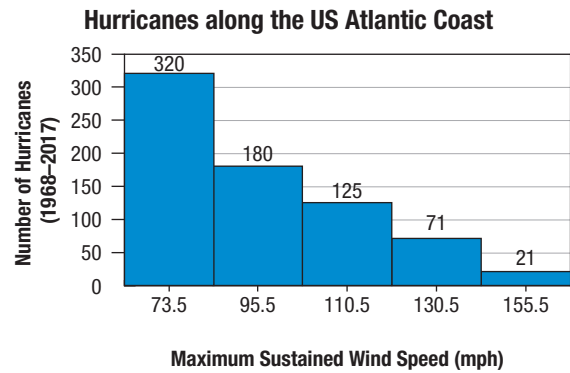

Source: Wikipedia. Atlantic hurricane season. [https://en.wikipedia.org/wiki/Atlantic\\_hurricane\\_season#Number\\_of\\_storms\\_of\\_each\\_strength\\_since\\_the\\_satellite\\_era](https://en.wikipedia.org/wiki/Atlantic_hurricane_season#Number_of_storms_of_each_strength_since_the_satellite_era) (18 July 2019).

24. Consider the following excerpt from an online publication. Is the graph correctly labeled? If not, identify the corrections needed.

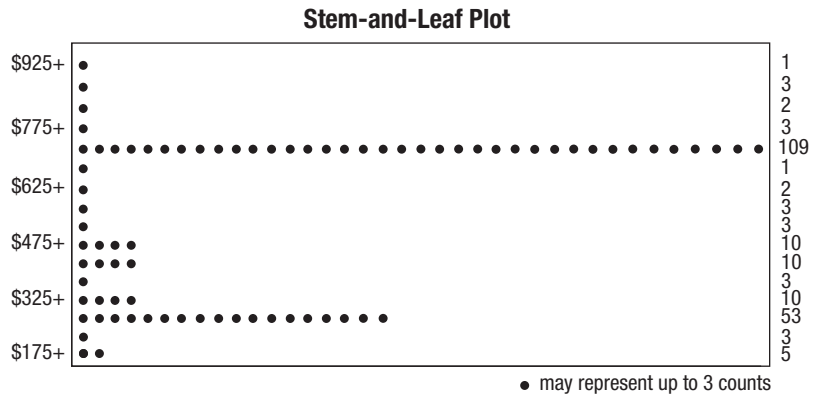

Source: NHHealthCost.org. "Health Costs for Consumers - Methodology." 16 Feb. 2007. <http://www.nhhealthcost.org/method.aspx> (24 Jan. 2012).

**WRITING & THINKING**

25. The following is a portion of a table about state health facts. It lists 8 of the 50 states along with the percentage of women age 50 and older who report having had a mammogram between 2008 and 2010.

**Percentage of Women Age 50 and Older Who Had a Mammogram Between 2008 and 2010**

<b>Massachusetts</b>	87.50%
<b>Connecticut</b>	83.80%
<b>North Carolina</b>	81.20%
<b>Virginia</b>	79.10%
<b>Alabama</b>	77.60%
<b>Mississippi</b>	70.90%
<b>Nevada</b>	69.90%
<b>Idaho</b>	68.30%

**Source:** Centers for Disease Control and Prevention (CDC). Behavioral Risk Factor Surveillance System Survey Data. Atlanta, Georgia: U.S. Department of Health and Human Services, Centers for Disease Control and Prevention, 2010, available at <http://apps.nccd.cdc.gov/brfss/list.asp?cat=WH&yr=2010&qkey=4427&state=All>

Is the following pie chart a good way to display this data? Explain why or why not.

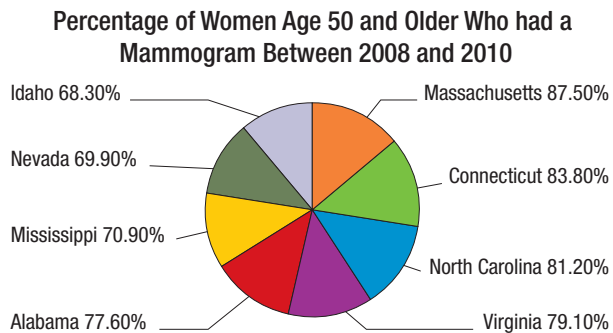

## 11.2 PROJECT

### FOLLOWING THE BOOMERS

The US population is comprised of seven living *generations*: the Greatest Generation (born 1901–1927), the Silent Generation (1928–1945), Baby Boomers (1946–1964), Generation X (1965–1980), Millennials (1981–1995), Generation Z (1996–2010), and Generation Alpha (2011–2025). In this project, you will construct a series of stacked, side-by-side bar charts that demographers call an *age pyramid* and focus on how one of these generations affects the pyramid. This pyramid distribution for human population has been observed throughout the history of mankind but, since the 1950s, an interesting trend has developed. Our goal is to identify that trend and offer a reasonable explanation for its occurrence. In the table<sup>17</sup> below, we have the distribution of the percentage of the US population

17 Paul Taylor, "The Next America." Pew Research Center, Washington, D.C. (April 10, 2014) <https://www.pewresearch.org/next-america/#Two-Dramas-in-Slow-Motion>. Pew Research Center bears no responsibility for the analyses or interpretations of the data presented here. The opinions expressed herein, including any implications for policy, are those of the author and not of Pew Research Center.

# 11.3 Exercises

## ✓ CONCEPT CHECK

1. The arithmetic mean is the \_\_\_\_\_ of all the data points \_\_\_\_\_ by the number of data points.
2. If a data set contains an \_\_\_\_\_ amount of values, the median is the middle value in the ordered list.
3. If a graph is skewed to the right, the majority of the data points fall on the \_\_\_\_\_ side of the distribution.
4. True or False: If all values in a data set are equal, the data set has no mode.
5. True or False: The values in a data set with a standard deviation of 3.5 is more spread out than the values in a data set with a standard deviation of 1.2.

## 💡 PRACTICE

Find the mean, median, mode, range, and standard deviation for each data set. When applicable state whether the data set is unimodal, bimodal, or multimodal. Round answers to one more decimal place than the largest number of decimal places given in the data. All data sets are samples unless stated otherwise.

6. 19, 32, 15, 21, 25, 22, 22, 28, 27, 27, 26
7. \$11.40, \$32.00, \$22.50, \$12.01, \$10.08, \$18.30, \$18.40, \$32.00
8. 45, 21, 26, 26, 45, 37, 22, 33, 26, 21, 42, 37, 41, 43, 46, 35, 31, 29, 46
9. 310, 310, 310, 310, 310, 310
10. 9, 3, -5, -3, -7, 3, 0, 6, -9, -7, -3, -8
11. The following data represent sample ACT scores from students at a local high school.

ACT Scores	
13	26
10	20
24	30
25	31
6	24
35	35
26	15

12. The following are lengths of each movie in the complete Harry Potter film series. Note that because these include all of the films in the series, this is a population.

Time Lengths for Harry Potter Film Series	
Movie Title	Time (in Minutes)
<i>Harry Potter and the Philosopher's Stone</i> (2001)	152 minutes
<i>Harry Potter and the Chamber of Secrets</i> (2002)	161 minutes
<i>Harry Potter and the Prisoner of Azkaban</i> (2004)	141 minutes
<i>Harry Potter and the Goblet of Fire</i> (2005)	157 minutes
<i>Harry Potter and the Order of the Phoenix</i> (2007)	138 minutes
<i>Harry Potter and the Half-Blood Prince</i> (2009)	153 minutes
<i>Harry Potter and the Deathly Hallows: Part 1</i> (2010)	146 minutes
<i>Harry Potter and the Deathly Hallows: Part 2</i> (2011)	130 minutes

For each data set, determine the most appropriate measure of center.

13. Styles of houses in a suburb: ranch, colonial, bungalow, etc.
14. Grades on the final in Biology 210 at State University.
15. The ratings on a customer satisfaction survey: strongly disagree, disagree, neither agree nor disagree, agree, and strongly agree.
16. Salaries for janitorial staff at the state governmental buildings that include the Director of Sanitation's salary.

### APPLICATIONS

Use the formula for the mean to find the missing piece of data.

17. John knows that his first 4 tests grades were 84, 79, 82, and 88. Find John's grade on the fifth test if his average was 83.8.
18. A family has four children. Edward has a height of 58 inches, David 52 inches, and Chloe 44 inches. How tall is Benjamin if the average height of the children is 52.5 inches?
19. Ella went to a butcher shop to buy some meat. She chose five pieces of meat, three of which weighed 960 g, 840 g, and 1120 g. If Ella needs at least 5 kilograms of meat, how much should the other two pieces weigh, on average?
20. Jacob and his five friends choose what drinks to order at a coffee shop. The first three people want a cappuccino for \$4.50, a latte for \$4.25, and hot tea for \$3.50. How much, on average, can the next three people spend on each drink if the total check should not exceed \$25?

21. Marcel scored in the 91st percentile on the MCAT (Medical College Admissions Test). The medical school he is applying to only accepts students who score in the top 10% on the MCAT. Did Marcel score well enough to be considered for his school of choice?
22. Suppose that 110 male students are surveyed and that 52% have a height less than 1.776 m.
- True or False: Of those surveyed, the mean height must be under 1.776 m.
  - True or False: Of those surveyed, the median height must be under 1.776 m.
23. If we know that a salary of \$65,300 was in the 67th percentile in a company survey, can we determine how many employees were in the sample? Why or why not?
24. People who are 6 feet and 1 inch tall are in the 90th percentile among American adults. Which of the following is the most likely percentile for people who are 6 feet and 7 inches tall: 80th, 85th, 90th, 95th, or 99th?
25. The average annual temperature in Georgia is at the 90th percentile among all the US states, while the temperature in North Carolina is at the third quartile. Which state has the higher average annual temperature?
26. Ethan's salary is at the third quartile at the company he works. His wife's salary is at the second quartile at the company she works. Are we able to determine which of them has a higher salary? Explain.
27. A doctor told Amelia that her child's weight was at the 30th percentile in the average growth chart. Does the child weigh more or less than the median weight for his age?
28. Last year, the Smiths were at the 72nd percentile of the nation's income distribution. This year, they are at the third quartile. Did their position go up or down?
29. Consider the prices of 20 used cars sold on an online platform.

\$24,400	\$25,270	\$27,570	\$33,430	\$28,500
\$33,340	\$33,760	\$37,240	\$23,270	\$24,790
\$21,590	\$21,870	\$33,650	\$35,890	\$30,560
\$34,910	\$38,680	\$36,310	\$36,640	\$36,030

- Find the five-number summary of the used car prices.
- What percentage of used car prices are at or below \$23,270?
- What is the range of used car prices on the platform?

30. Consider the given box plot.

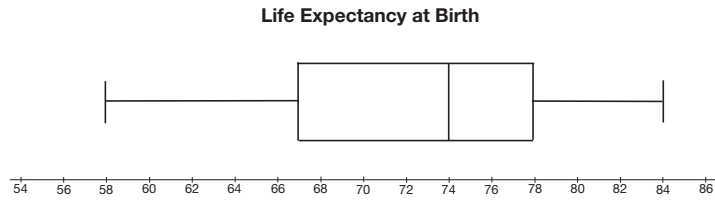

- a. Based on the boxplot, estimate each of the values in the five-number summary.
- b. The midrange is the average of the minimum and maximum data values. Estimate the mid-range from the box plot.

31. Calculate the values needed to construct a box plot for the following data. Sketch a graph of the box plot.

26	26	26	34	40	46	54
58	64	74	74	76	82	82
86	96	100	110	110	112	112
116	120	130	158	162	166	168

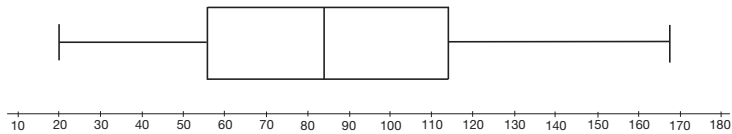

32. Given the five-number summary for three data sets, sketch a box plot for each, side-by-side on the same graph. Then answer the following questions based on your box plots.

<b>Weight of Adult Male Dogs by Breed (in pounds)</b>			
	<b>English Mastiffs</b>	<b>Golden Retrievers</b>	<b>Rottweilers</b>
<b>Min</b>	190	55	95
<b><math>Q_1</math></b>	205	65	105
<b><math>Q_2</math></b>	220	68	112
<b><math>Q_3</math></b>	225	70	120
<b>Max</b>	240	85	135

- a. Which breed has the largest range of weight?
- b. Which breed has the least variation in weight?
- c. Which breed has the largest median weight?

33. The following are house prices in one neighborhood.

\$181,865	\$119,442	\$152,750	\$100,960	\$159,635
\$150,963	\$133,702	\$149,788	\$145,495	\$182,500
\$112,021	\$120,900	\$145,850	\$164,590	\$144,413

- Find the five-number summary of the house prices.
  - What percentage of house prices is at or below \$159,635?
  - What is the range of house prices for this neighborhood?
34. The following graph contains a box plot.

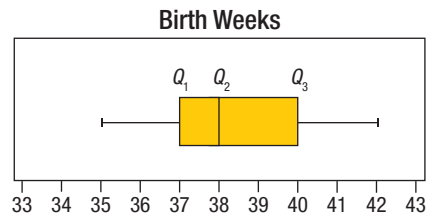

- Based on the box plot, estimate each of the values in the five-number summary.
  - The midrange is the average of the minimum and maximum data values. Estimate the midrange from the box plot.
35. Calculate the values needed to construct a box plot for the following data. Sketch a graph of the box plot.

310	320	450	460	470	500	520	540
580	600	650	700	710	840	870	900
1000	1200	1250	1300	1400	1720	2500	3700

36. Given the five-number summary for three data sets, sketch a box plot for each, side-by-side on the same graph. Then answer the following questions based on your box plots.

<b>Committees and the Ages of Members</b>			
	<b>Membership</b>	<b>Finance</b>	<b>Publicity</b>
<b>Min</b>	23	26	25
<b><math>Q_1</math></b>	27	32	26
<b><math>Q_2</math></b>	29	38	27
<b><math>Q_3</math></b>	33	44	29
<b>Max</b>	35	46	33

- Which committee has the largest range of ages?
- Which committee has the least variation in the ages?
- Which committee has the smallest median?

 WRITING & THINKING

37. Accounting 101 has five class sections. All five classes took the same final. The mean scores on the final for each class were 72, 78, 76, 74, and 79. Can the mean final score for all students in Accounting 101 be found by averaging the mean scores in each class? Explain your answer.
38. Does the standard deviation of a data set equaling zero imply that all entries in the data set equal zero?
39. Explain the difference between Amelia making an 82 on her pre-calculus exam and scoring in the 82nd percentile in mathematics on the ACT test.
40. Describe two data sets, one that might have a large variation and one that might have a small variation.
41. Lucas received an e-mail containing the five-number summary for the company sales data that he asked for. Unfortunately, the e-mail cut off the summary labels and scrambled their order. Can you still determine which number is the first quartile,  $Q_1$ ? Explain your answer.

five-number summary: 11, 17.5, 9, 13.5, 19

# 11.4 Exercises

## ✓ CONCEPT CHECK

1. A \_\_\_\_\_ variable is a variable that can only take on certain values.
2. A \_\_\_\_\_ variable is a variable that can take on any value in a given interval.
3. A standard score indicates how many \_\_\_\_\_ a data value lies away from the mean in a normal distribution.
4. True or False: According to the Empirical Rule, 99.7% of all data points in a data set lie within 2 standard deviations of the mean.
5. True or False: To find the area under a normal curve that lies to the right of a given  $z$ -value, look up the negative of the  $z$ -value in the Standard Normal Distribution table.

## 💡 PRACTICE

6. Below are three normal distributions representing the height of adults in China, France, and Norway. Use the graph to answer the following questions.

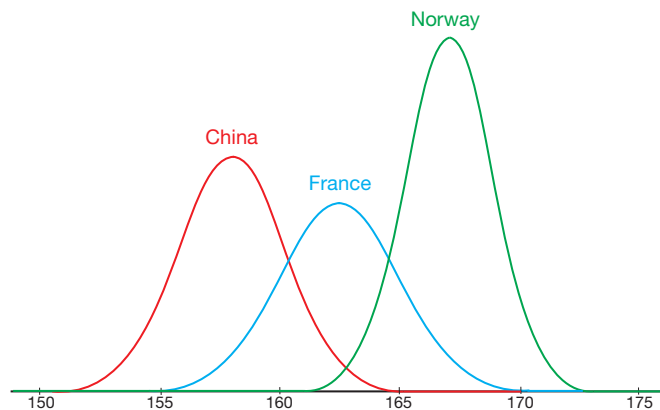

- a. Determine which distribution has the largest mean and which has the smallest.
- b. Determine which distribution has the largest standard deviation and which has the smallest.
- c. What can you conclude about the heights of people in China and Norway?

7. Below are three normal distributions representing the prices of BMW X1, X2, and X3 models. Use the graph to answer the following questions.

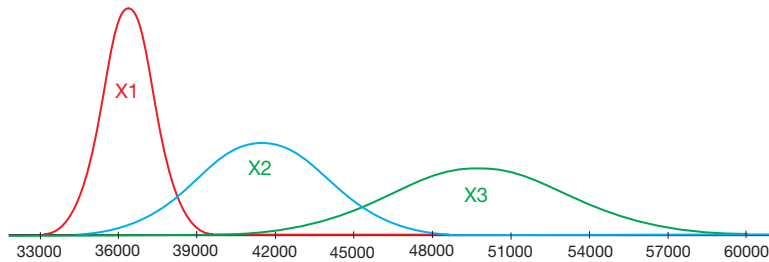

- a. Determine which distribution has the largest mean and which has the smallest.
- b. Determine which distribution has the largest standard deviation and which has the smallest.
- c. What can you conclude about the prices of BMW X1 and X2 models?

Calculate the standard score for each given value. Round your answer to the nearest hundredth.

8.  $\mu = 57, \sigma = 11$

- a.  $x_1 = 63$
- b.  $x_2 = 38$
- c.  $x_3 = 58$

9.  $\bar{x} = 1123, s = 241$

- a.  $x_1 = 1284$
- b.  $x_2 = 900$
- c.  $x_3 = 1364$
- d.  $x_4 = 1123$

10.  $\bar{x} = 3.19, s = 0.06$

- a.  $x_1 = 3.13$
- b.  $x_2 = 3.22$
- c.  $x_3 = 3.00$

11.  $\mu = 178.15, \sigma = 49.3$

- a.  $x_1 = 73.9$
- b.  $x_2 = 267.3$
- c.  $x_3 = 199.5$

Use the z-score formula to complete each table.

12. Find the missing value in each row of the table. Round answers to the same number of decimal places given in the table.

	$z$	$x$	$\mu$	$\sigma$
a.		82.1	74.0	6.3
b.	1.05	162.3		8.9
c.	3.04		34.5	5.02
d.	-2.73	379	634	

13. Find the missing value in each row of the table. Round answers to the same number of decimal places given in the table.

	$z$	$x$	$\mu$	$\sigma$
a.		4.33	6.10	2.04
b.	-2.39	-57		139.8
c.	0.58		118	21.2
d.	2.78	68	43	

Find the percentage of data points that lie below each  $z$ -score.

14.  $z = -0.19$                       15.  $z = 1.46$                       16.  $z = 3.07$
17.  $z = -2.22$                       18.  $z = 0$

Find the percentage of data points that lie above each  $z$ -score.

19.  $z = 1.03$                       20.  $z = -1.87$                       21.  $z = -3.10$
22.  $z = 2.84$                       23.  $z = 0$

Find the percentage of data points that lie between each pair of  $z$ -scores.

24.  $z_1 = -1.00$                       25.  $z_1 = -2.40$                       26.  $z_1 = 2.00$   
 $z_2 = 1.00$                                        $z_2 = 1.73$                                        $z_2 = 3.00$
27.  $z_1 = -3.01$                       28.  $z_1 = 0$   
 $z_2 = -0.56$                                        $z_2 = 2.61$

Find the percentage of data points that lie below  $z_1$  and above  $z_2$ .

29.  $z_1 = -1.10$                       30.  $z_1 = -2.84$                       31.  $z_1 = -1.75$   
 $z_2 = 1.10$                                        $z_2 = 2.84$                                        $z_2 = 0.53$
32.  $z_1 = 1.09$                       33.  $z_1 = -0.01$   
 $z_2 = 2.88$                                        $z_2 = 0.02$

### APPLICATIONS

34. Scores on a test have a mean of 73 and a standard deviation of 11. Steve has a score of 68. Convert Steve's score to a  $z$ -score.
35. The annual rainfall in a town has a mean of 47.22 inches and a standard deviation of 10 inches. Last year there was 51 inches of rain. How many standard deviations from the mean is that?
36. Mason's weekly poker winnings have a mean of \$144 and a standard deviation of \$51. Last week he won \$165. How many standard deviations from the mean is that?

37. The mean score for a set of data is marked by the dotted line on the following graph. Which value is a likely  $z$ -score for the indicated value? Choose from **a.**  $-2.1$ , **b.**  $0$ , or **c.**  $2.7$ .

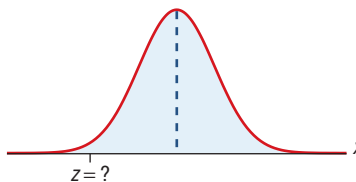

38. The average IQ score for adults is 100 with a standard deviation of 15. Assume that the distribution of IQ scores is approximately normal.
- Find the percentage of adults who have an IQ score less than 90.
  - Find the percentage of adults who have an IQ score which exceeds the mean by at least 15 points.
  - Find the percentage of adults who have an IQ score between 100 and 120.
  - Find the percentage of adults who have an IQ score less than 55 or more than 145.
39. Assume the weights of offensive linemen in the NFL follow a normal distribution with a mean of 300 pounds and a standard deviation of 12.3 pounds.
- Find the percentage of linemen in the NFL who weigh more than 320 pounds.
  - Find the percentage of linemen in the NFL who weigh between 275 and 325 pounds.
  - Find the percentage of NFL linemen who weigh at least 260 pounds.
  - Find the percentage of NFL linemen who weigh at most 315 pounds.
40. Although there is some controversy around the precise average body temperature of adults, new data suggest that the mean is  $98.2^\circ$  with a standard deviation of  $0.6^\circ$  and has a bell-shaped distribution.
- According to this distribution, approximately what percentage of body temperatures are between  $97^\circ$  and  $99.4^\circ$ ?
  - Approximately what percentage of temperatures are greater than  $98.8^\circ$ ?
  - Approximately what percentage of temperatures are no more than  $98.2^\circ$ ?
41. In 2011, high school seniors had the following mean and standard deviation on the mathematics portion of the SAT exam:  $\mu = 514$  and  $\sigma = 117$ .
- Approximately what percentage of scores were greater than 397 but less than 631?
  - What two scores have approximately 95% of the data between them?
  - Describe where the best and worst 0.3% of scores lie.

42. The speeds of vehicles on a certain part of a highway are normally distributed with a mean of 60 mph and a standard deviation of 6 mph. Use the Empirical Rule to answer the following questions.
- Approximately what percentage of vehicles travel at a speed between 54 mph and 66 mph?
  - Approximately what percentage of vehicles travel at a speed greater than 72 mph?
  - Approximately what percentage of vehicles travel at a speed not greater than 78 mph?
43. A machine is set to pour a mean of 497 mL of spring water in each bottle with a standard deviation of 2 mL. Assume that the distribution of the amount of water is bell-shaped. Use the Empirical Rule to answer the following questions.
- Approximately what percentage of bottles filled by the machine contain more than 491 mL and less than 503 mL of water?
  - Between what two amounts of water will 68% of all bottles contain?
  - How much water will the top 2.5% of bottles contain? How much water will the bottom 2.5% of bottles contain?
44. Ava scored a 92 on a test with a mean of 71 and a standard deviation of 15. Charlotte had a score of 688 on a test with a mean of 493 and a standard deviation of 150. Which score was better with respect to their test?
45. Avery started training to run a 5K. Her first race was a 5K for charity. She finished in 37.3 minutes. The average race time for the charity run was 36.42 with a standard deviation of 1.73 minutes. In her second race, Avery finished in 36.5 minutes. The race had a mean time of 33.02 minutes with a standard deviation of 2.45 minutes. In which race did Avery place higher in the list of finishers?
46. Michael works at a company where the mean annual salary is \$37,000 with a standard deviation of \$6800. Daniel works at a company where the mean annual salary is \$39,000 with a standard deviation of \$8200. If they both have a salary of \$35,000, whose salary is better compared to the other people in their respective companies? Assume that the salaries are normally distributed.
47. The average height of students in Class A is 59.6 inches with a standard deviation of 2.7 inches. The average height of students in Class B is 57.2 inches with a standard deviation of 2.4 inches. Amanda is in Class A and is 62.2 inches tall. Sofia is in Class B and is 60.1 inches tall. Which girl is taller compared to the rest of their respective classes?
48. The Intelligence Quotient (IQ) score is one way to measure human intelligence. It is determined using a set of tests and then standardized to have a normal distribution with the mean of 100 and the standard deviation of 15. What percentage of people have an IQ score higher than 125?

49. The average weight of newborn boys in the US is 3530 grams with a standard deviation of 577 grams. Assuming that the distribution of weights is normal, what percentage of newborn boys weigh less than 3 kilograms?
50. Suppose you want to determine the voltage in a circuit, and your voltmeter allows you to find the voltage with a standard deviation of 0.65 volts. If the exact voltage is 95 volts, what is the probability that you obtain a value greater than or equal to 96 volts?
51. The systolic blood pressure of healthy adults is normally distributed with a mean of 116 mm Hg and a standard deviation of 23 mm Hg. However, if the blood pressure is higher than 130 mm Hg at rest, it can be a sign of hypertension. With this in mind, what percentage of healthy adults have blood pressure higher than 130 mm Hg?
52. Assume that the retirement age of people in a certain country is normally distributed with a mean of 62.4 years and a standard deviation of 2.7 years. What percentage of people in the country retire before the age of 60?
53. Assume that the daily milk yield of a cow has a normal distribution with a mean of 25 liters and a standard deviation of 7.5 liters. What is the probability that the cow will produce less than 20 liters of milk in a day?

### WRITING & THINKING

54. What is the minimum  $z$ -score that a piece of data would need to have in order to be in the top 10% of a normally distributed set of data?
55. What is an “average”  $z$ -score? Explain your answer.
56. What  $z$ -score represents the 1st quartile? 2nd quartile? 3rd quartile?

## 11.4 PROJECT

### IS THAT NORMAL?

In Section 11.4, you learned how to use a normal distribution to calculate  $z$ -scores and answer questions about probability. We found that variables such as height, body temperature, weight, and blood pressure are common examples of data that are normally distributed. Because of the relative ease of calculating probabilities using normal distributions, it’s tempting to assume, when collecting and analyzing data, that the variable or characteristic in question has a normal distribution. However, if the data set doesn’t have a normal distribution, any conclusions we draw using standard scores is suspect at best. Fortunately, there is a method available to check the data beforehand and determine whether the population from which the data are taken has a normal distribution. It is called a *normality test*.

#### Normality Test

**Step 1:** Sort the data values so they are arranged from smallest to largest, and assign a rank to each value with 1 corresponding to the smallest value and  $n$  corresponding to the largest value, where  $n$  is equal to the sample size.

Thus, the 95% confidence interval for the percentage of American adults who say they have “a little” awareness of facial recognition technology is (59.1%, 62.9%).

- b. To establish if there is a statistical difference between the two subgroups, we can look at the confidence intervals for each of them and determine if the intervals overlap. If they do overlap, we cannot say that there is a statistical difference between the two. If they do not overlap, we can be 95% confident that one population parameter is different than the other. Begin by constructing the confidence intervals in the same manner as in part a., using the margin of errors given for each subpopulation.

**Table 11.5.3**

Age Group	Sample Proportion Who Responded “A Lot”	Margin of Error	95 % Confidence Interval for the Population Percentage
18- to 29-year-olds	29%	4.8%	(24.2%, 33.8%)
65+	20%	3.8%	(16.2%, 23.8%)

Notice that the confidence intervals for the two age groups do not overlap. Therefore, we can say that we are 95 % confident that 18- to 29-year-olds are more likely to say they know “a lot” about facial recognition technology than those 65 years old and older.

### Skill Check Answers

1.  $\frac{301}{432} \approx 0.697$     2. (27.2%, 30.8%)    3. 3.3%

## 11.5 Exercises

### ✓ CONCEPT CHECK

- A \_\_\_\_\_ is a single-number estimate of a population parameter.
- The margin of error is the largest possible distance from the \_\_\_\_\_ that a confidence interval will cover.
- The range of all possible values for a population parameter is called the \_\_\_\_\_.
- True or False: The level of confidence describes the likelihood that the data value in question will fall within the corresponding confidence interval.

### APPLICATIONS

Find each specified point estimate or confidence interval.

5. A survey of 42 randomly selected teachers finds that they spend a mean of \$18 per week on lunch. What is the best point estimate for the mean amount of money spent per week on lunch for all teachers?
6. The mean number of pets per student for a random sample of 47 students at Brown Elementary is 2.5 pets. What is the best point estimate for the mean number of pets per student for all students at Brown Elementary?
7. A survey of teachers reports that a point estimate for the mean amount of money spent each week on lunch is \$18.00. If the margin of error for a 95% confidence interval for the mean amount of money spent each week on lunch by all teachers is \$1.70, construct a 95% confidence interval for the mean amount of money spent each week on lunch for all teachers.
8. The mean batting average for a random sample of 35 professional baseball players is .283. If the margin of error for the population mean with a 99% level of confidence is .051, construct a 99% confidence interval for the mean batting average for professional baseball players.
9. The following graph<sup>19</sup> shows the 95% confidence intervals for mortality rates across several countries from 2010 to 2016. The middle point of each segment indicates the mean. Use the graph to answer the following questions.

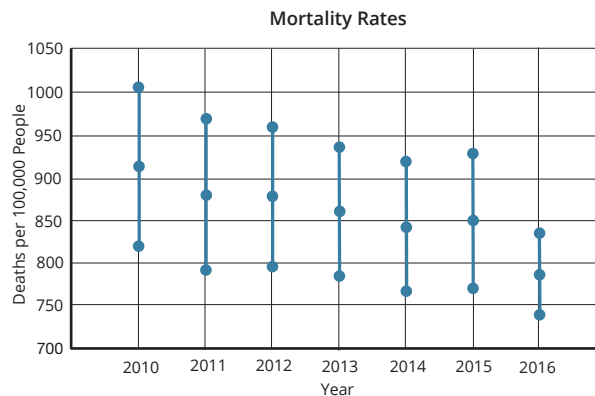

- a. Approximate the 95% confidence interval for 2010. Based on this, what can you say about the mortality at this point?
- b. Can we say with certainty that the 2012 mortality rate is below 900 deaths per 100,000 people? Explain your answer.
- c. Is there a year that we can be certain has a mortality rate below 850 deaths per 100,000 people?
- d. Compare the mortality rates for 2015 and 2016.

<sup>19</sup> "Health Status," Organisation for Economic Co-Operation and Development, accessed January 4, 2022, [https://stats.oecd.org/Index.aspx?DatasetCode=HEALTH\\_STAT](https://stats.oecd.org/Index.aspx?DatasetCode=HEALTH_STAT).

10. The following graph<sup>20</sup> shows the 95% confidence intervals for the number of cancer cases in several countries in 2000, 2002, 2008, and 2012. The middle point of each segment indicates the mean. Use the graph to answer the following questions.

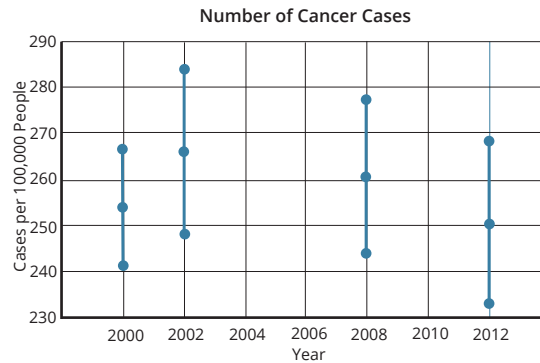

- Approximate the 95% confidence interval for 2000. Based on this, what can you say about the number of cancer cases in 2000?
  - Can we say with certainty that there were fewer than 280 cancer cases per 100,000 people in 2002? Explain your answer.
  - Is there a year that we can be certain had fewer than 270 cancer cases per 100,000 people?
  - Compare the number of cancer cases in 2000 and 2002.
11. While testing a new anesthetic drug, the researchers found that the 90% confidence interval for the percentage of patients whose pain is completely relieved by the drug is (76.2%, 81.4%). Interpret their results.
12. A survey was taken of 1028 high school students asking if they listen to music for more than two hours per day. The 95% confidence interval for such students is (71.8%, 78.0%). Interpret the result of the survey.

Construct and interpret each specified confidence interval.

13. A professor wants to estimate how many hours per week her students study. A simple random sample of 78 students had a mean of 15.0 hours of studying per week with a standard deviation of 2.3 hours per week. Construct and interpret a 90% confidence interval for the mean number of hours a student studies per week if the margin of error for the data using a 90% level of confidence is  $E = 0.4$ .
14. A faculty advocacy group is concerned about the amount of time teachers spend each week doing schoolwork at home. A simple random sample of 56 teachers had a mean of 8.0 hours per week working at home after school with a standard deviation of 1.5 hours per week. Construct and interpret a 95% confidence interval for the mean number of hours per week a teacher spends working at home if the margin of error for the data using a 95% level of confidence is  $E = 0.4$ .

<sup>20</sup> "Health Status," Organisation for Economic Co-Operation and Development, accessed January 4, 2022, [https://stats.oecd.org/Index.aspx?DatasetCode=HEALTH\\_STAT](https://stats.oecd.org/Index.aspx?DatasetCode=HEALTH_STAT).

15. A writer for a computer magazine is working on an article about computer usage in American households. A simple random sample of 120 American households has a mean computer usage time of 19.2 hours per week with a standard deviation of 3.3 hours per week. Construct and interpret a 95% confidence interval for the mean computer usage time per week for all American households if the margin of error for the data using a 95% level of confidence is  $E = 0.6$ .
16. A survey of 85 randomly selected homeowners finds that they spend a mean of \$67 per month on home maintenance with a standard deviation of \$14 per month. Construct and interpret a 99% confidence interval for the mean amount of money spent per month on home maintenance by all homeowners if the margin of error for the data using a 99% level of confidence is  $E = 4$ .
17. A survey of 97 randomly selected homeowners found that the mean amount spent on lawn service was \$720 per year with a standard deviation of \$123 per year. Construct and interpret a 98% confidence interval for the mean amount of money spent on lawn service per household each year if the margin of error for the data using a 98% level of confidence is  $E = 29$ .
18. A survey of a simple random sample of 140 dieters revealed that the numbers of times they “cheated” on their diets had a mean of 7.0 times per week with a standard deviation of 1.5 times per week. Construct and interpret a 99% confidence interval for the mean number of times dieters “cheat” on their diets each week if the margin of error for the data using a 99% level of confidence is  $E = 0.3$ .
19. A physical therapist is investigating the mean recovery time after ACL surgery for patients involved in a new therapy regimen. For the purpose of the study, a successful recovery was defined to be the ability to walk without crutches. For 38 randomly selected patients, the mean recovery time after ACL surgery was found to be 22.6 days with a standard deviation of 3.7 days. Find and interpret a 99% confidence interval for the mean recovery time for all ACL surgery patients undergoing the same new therapy if the margin of error for the data using a 99% level of confidence is  $E = 1.5$ .
20. The manufacturers of Caudill automotive oil wish to estimate the mean number of miles that motorists drive between oil changes. A random sample of 54 motorists has a mean of 5900 miles driven between oil changes with a standard deviation of 1350 miles. Construct and interpret a 95% confidence interval for the mean number of miles driven between oil changes for all motorists if the margin of error for the data using a 95% level of confidence is  $E = 360$ .
21. Thirteen out of 147 randomly selected faculty members who were surveyed at a community college know sign language. Use the rule of thumb to construct and interpret a 95% confidence interval for the percentage of all faculty members at the community college who know sign language. If necessary, round your upper and lower endpoints to the nearest hundredth.
22. A random sample of 200 computer chips is obtained from one factory and 4% are found to be defective. Construct and interpret a 95% confidence interval for the proportion of all computer chips from that factory that are defective if the margin of error for the data using a 95% level of confidence is  $E = 2.7\%$ .

23. Out of 140 randomly selected kindergartners who were surveyed, 32 said that pancakes are their favorite breakfast food. Use the rule of thumb to construct and interpret a 95% confidence interval for the percentage of all kindergartners who say pancakes are their favorite breakfast food. If necessary, round your upper and lower endpoints to the nearest hundredth.
24. Out of 543 randomly selected patients of a local hospital who were surveyed, 492 reported that they were satisfied with the care they received. Use the rule of thumb to construct and interpret a 95% confidence interval for the percentage of all patients satisfied with their care at that hospital. If necessary, round your upper and lower endpoints to the nearest hundredth.
25. A survey of 145 randomly selected students at one college showed that only 87 checked their campus e-mail account on a regular basis. Use the rule of thumb to construct and interpret a 95% confidence interval for the percentage of students at that college who do not check their e-mail account on a regular basis. If necessary, round your upper and lower endpoints to the nearest hundredth.
26. A random sample of 200 computer chips is obtained from one factory and 4% are found to be defective. Construct and interpret a 99% confidence interval for the percentage of all computer chips from that factory that are *not* defective if the margin of error for the data using a 99% level of confidence is  $E = 3.6\%$ .
27. The Pew Research Center surveyed pairs of US teens and one of their parents in 2019. Their website provides a breakdown of the sample size along with the margin of error for a 95% confidence interval for the overall survey as well as for different subgroups of data.

Teen Group	Unweighted Sample Size	Margin of Error
Total teen Sample	1811	3.1 percentage points
All religiously affiliated teens	1246	3.7 percentage points
Christian	1179	3.9 percentage points
Protestant	680	5.2 percentage points
Evangelical	407	6.6 percentage points
Mainline	208	9.0 percentage points
Catholic	428	6.4 percentage points
Unaffiliated	555	5.7 percentage points

Source: "Methodology," Pew Research Center, September 8, 2020, <https://www.pewforum.org/2020/09/10/methodology-34/>.

- a. Use the data in the table to create a graph of the sample sizes of each category versus the margin of error percentage points. For each point  $(x, y)$ , let  $x$  represent the sample size and  $y$  represent the margin of error.
- b. Based on the graph from part a., what can you say about the margin of error compared with the sample size?
- c. Is it possible to create confidence intervals for the population percentages in each category using the data from the table?



28. The Pew Research Center surveyed US adult Twitter users in 2021 and reported the following.

“Seven in ten US adult Twitter news consumers have followed breaking news there.”

Their website provides a breakdown of the sample size along with the margin of error for a 95% confidence interval for the overall survey as well as for different subgroups of data.

Group	Unweighted Sample Size	Margin of Error
Total Sample	2548	3.4 percentage points
Gets news on Twitter	1783	4.0 percentage points
Does not get news on Twitter	751	6.1 percentage points
Among those who get news on Twitter		
Rep / Lean Rep	452	7.7 percentage points
Dem / Lean Dem	1311	4.8 percentage points

Source: “Methodology,” Pew Research Center, November 15, 2021, <https://www.pewresearch.org/journalism/2021/11/15/new-on-twitter-methodology/>.

- Use the data in the table to create a graph of the sample sizes of each category versus the margin of error percentage points. For each point  $(x, y)$ , let  $x$  represent the sample size and  $y$  represent the margin of error.
  - Based on the graph from part a., what can you say about the margin of error compared with the sample size?
  - Is it possible to create confidence intervals for the population percentages in each category using the data from the table?
29. The Pew Research Center reported the following based on a survey conducted among 4860 US adults.

“47% of Americans say dating is now harder than it was 10 years ago, while 19% say it’s easier and 33% say it’s about the same.”

Their website provides the margin of error of 2.1 percentage points for a 95% confidence interval for the overall survey. Interpret the provided margin of error.

30. A 2021 survey of US adults found that “Many Americans continue to experience mental health difficulties as pandemic enters second year. [...] Psychological distress is especially common among adults with lower family incomes.” Use the information in the table to answer the following questions.

Group	High Distress	Medium Distress	Low Distress	Unweighted Sample Size	Margin of Error (for 95% Confidence)
Upper Income	13%	22%	65%	2767	2.7%
Middle Income	18%	24%	56%	4810	2.2%
Lower Income	31%	25%	42%	2119	3.4%

Source: Pew Research Center, February 2021, <https://www.pewresearch.org/facttank/2021/03/16/many-americans-continue-to-experience-mental-health-difficulties-as-pandemic-enters-second-year/>.

- a. Construct a 95% confidence interval for the proportion of American adults with middle income who would say they have high distress.
- b. Is it correct to say that people with lower income are more likely to say they are highly distressed than those with upper income? Explain why or why not.
31. A 2021 survey of US adults found that “About seven-in-ten US adults say major tech companies have too much economic power and influence.” Use the information in the table to answer the following questions.

Group	Too much	About the Right Amount	Not Enough	Unweighted Sample Size	Margin of Error (for 95% Confidence)
US Adults	68%	25%	4%	4623	2.2%
Rep/Lean Rep	74%	22%	2%	1899	3.3%
Dem/Lean Dem	64%	29%	5%	2603	3.0%

Source: Pew Research Center, July 20, 2021, <https://www.pewresearch.org/facttank/2021/07/20/56-of-americans-support-more-regulation-of-major-technology-companies/>.

- a. Construct a 95% confidence interval for the proportion of American adults who would say major technology companies have too much power and influence in today’s economy.
- b. Is it correct to say that Republicans are more likely to say technology companies have too much power than Democrats? Explain why or why not.
32. Suppose a poll was taken of 3196 high-school seniors to investigate how many of them plan to go to college. The researchers learned that 68.7% plan to go to college.
- a. Use the rule of thumb to calculate the margin of error for a 95% confidence interval.
- b. Interpret the obtained margin of error and the interval.
33. According to the 2019–2020 National Pet Owners Survey, 67% of US households own a pet. Suppose another survey was taken of 1352 US households. The researchers determined that 59.3% of them own a pet.
- a. Use the rule of thumb to calculate the margin of error for a 95% confidence interval.
- b. Interpret the obtained margin of error and the interval.

## 12.1 Exercises

### ✓ CONCEPT CHECK

1. \_\_\_\_\_ is the understanding of the particular field of interest for the question being investigated.
2. When forming the questions to be answered, it is important to avoid subjective \_\_\_\_\_.
3. True or False: When working through the steps of the scientific method for data science, you cannot backtrack to a previous step.
4. True or False: In data science, a broad and less-defined question will yield more useful results than a narrow and well-defined question.

### APPLICATIONS

5. As part of a research project, you need to analyze the effects of caffeine on the productivity of nightshift workers. Answer the following questions to outline how you would work through the scientific method for data science.
  - a. What question can you pose to start your investigation?
  - b. Where might you find the data related to your investigation?
  - c. What are some ways you might explore the data to notice patterns or trends?
  - d. What are some ways you can model the data once it is cleaned up?
  - e. What might be an engaging way to communicate the results given the topic of the project?
6. As part of a research project, you need to help a local restaurant determine what type of weekly special will increase sales. Answer the following questions to outline how you would work through the scientific method for data science.
  - a. What question can you pose to start your investigation?
  - b. Where might you find the data related to your investigation?
  - c. What are some ways you might explore the data to notice patterns or trends?
  - d. What are some ways you can model the data once it is cleaned up?
  - e. What might be an engaging way to communicate the results given the topic of the project?
7. As part of a research project, you need to determine the minimum inventory a store should keep in stock to be prepared for Thanksgiving holiday shopping. Answer the following questions to outline how you would work through the scientific method for data science.
  - a. What question can you pose to start your investigation?
  - b. Where might you find the data related to your investigation?
  - c. What are some ways you might explore the data to notice patterns or trends?

- d. What are some ways you can model the data once it is cleaned up?
- e. What might be an engaging way to communicate the results given the topic of the project?

Identify a weakness in each research question. Then, give three stronger alternative questions.

- 8. When is the best time to post on social media?
- 9. How should the next iteration of the flagship smartphone be updated?
- 10. How does the consumption of aspartame affect overall health in comparison to the consumption of sugar?
- 11. Is it better to brush your teeth before flossing or better to floss before brushing your teeth?
- 12. Will an afterschool tutoring program improve student performance?
- 13. Does meditating improve focus?

For each situation, identify three questions that a data scientist who is unfamiliar with the specific domain knowledge indicated can ask their team to help strengthen their research process.

- 14. A sales and marketing department want to know how they can improve packaging to make a low-selling product look more enticing to customers.
- 15. The owner of a bakery wants to know the best way to increase sales of beverages that are sold along with the baked goods.
- 16. A nonfiction book publisher wants to know if they should extend their product lines into historical nonfiction books.
- 17. The human resources department of a company is interested in learning what steps can be taken to increase employee retention.
- 18. A small business wants to know how to decrease the time spent processing orders for shipment.
- 19. The owner of a museum wants to know the best way to redesign the ticket lobby so there is less congestion between the ticket lines and the entrance and exit of the museum.

Finally, it is important to note that data cleaning and parsing shouldn't be considered a one-time job, but a reoccurring process. As you get to know your data, it often sparks new ideas and ways in which to transform the information. Once in the analysis stage, you may need to return to wrangling in order to parse the data differently after you've noticed an interesting insight or a stubborn roadblock.

**Table 12.2.2:** Summary Table of Excel Tools and Functions for Cleaning

	What it does	Location/Syntax
<b>Text to Columns</b>	Takes text in one or more cells and splits it across multiple cells.	Found on the Data Tab.
<b>TRIM</b>	Removes all spaces from a text string except for single spaces between words.	TRIM(text)
<b>Find and Replace</b>	Locates particular number of text string and replaces it with something else.	Found on the Home Tab, in the Editing section
<b>MID</b>	Returns a specific number of characters from a text string, starting at the position you specify, based on the number of characters you specify.	MID(text, start_num, num_chars)
<b>FIND</b>	Locates one text string within a second text string and returns the number of the starting position of the first text string from the first character of the second text string.	FIND(find_text, within_text, [start_num])
<b>LOOKUP</b>	Searches a row or column for a value.	LOOKUP(lookup_value, lookup_vector, [result_vector])

**Skill Check Answers**

1. 9 columns 2. pet 3. Rows 3 and 6 4. a. January: Marcel Canton; February: Becca Harold; March: William Benton; b. William Benton 5. Answers could include student IDs or SSN numbers

## 12.2 Exercises

✓ **CONCEPT CHECK**

1. Data wrangling is the process of acquiring \_\_\_\_\_ data, cleaning it, organizing it, and transforming it so that the data is \_\_\_\_\_.
2. In Excel, the \_\_\_\_\_ function allows you to extract a defined number of characters from a string of text.
3. In Excel, the \_\_\_\_\_ function can find information in an array of data based on a specified identifier.
4. True or False: Excel reads a space as a character.
5. True or False: Pivot tables can summarize the information in a large data set into table.

 PRACTICE

For each data file snippet, determine the delimiter that would be used to separate the data into columns and determine how many columns the data would be separated into.

6. Date,Time,PurchaseTotal,PaymentMethod  
01072021,1132,\$523.45,Credit  
02072021,1623,\$723.11,Paypal  
02072021,1704,\$312.77,Credit
7. CustID;Age;Birthdate;Membership;AutoRenew;Flavor  
021789;44;07161976;Premium;Yes;Raspberry  
022893;30;01011990;Basic;Yes;Chocolate  
023113;35;03301985;Premium;No;Vanilla
8. ItemName Size Inventory Price LastReordered  
PinkShirtSS S 24 \$18.99 07/23/21  
PinkShirtLS M 15 \$19.99 03/12/21  
GreenShirtSS L 12 \$18.99 05/15/21
9. Title,Author,Page Count,Word Count,Star Rating,Copies Sold (Millions),List Price  
A Grand Scheme,Lynn Minning,277,73682,4.2,1.73,\$15.99  
The Princess Pickle,Susie Roadings,298,82546,3.8,2.77,\$16.50  
The Scout,Allison Feist,308,81620,4.3,3.85,\$14.99

Describe the inconsistencies in the data in each spreadsheet and explain the steps that should be taken to clean up the data.

10.

	A	B	C	D	E
1	Date	Time	Customer Name	Email Address	Subscription
2	11-10-2022	0732	Emmet Murphy		Premium
3	10.12.2022	1157	Susan Franklin	Sfranks@emails.com	Basic
4	12-10-2022	2005	Kyla Jones	no@no.no	Basic
5					
6	13-10-2022	1053	Ed	ed@edssite.co	Premium
7	10.13.2022	1442	Stephen Moore	SMoore@yahoos.com	Basic

11.

	A	B	C	D	E
1	Chapter	Status	Page Count	Approved	Editor
2		1 Finalized	72	No	Susan
3		2 Draft	55	No	Kyle
4		3 Editing	58	No	Antonio
5		3 Editing	58	No	Antonio
6		5 Draft	73		Susan
7		6 Finalized	60	Yes	Kyle
8		7 Finalized	63	Yes	Antono
9		8 Draft	59	No	Susan

12. Which of the following data will Excel find if you run the command “Find \*ing” and select the “Match case” option?
- a. swing
  - b. JUMPING
  - c. Ingress
  - d. ingested
13. Which of the following data will Excel find if you run the command “Find s?n”?
- a. sand
  - b. spin
  - c. sin
  - d. stain

Determine the output of each Excel function.

14. MID(“Once upon a time, there lived a lovely princess”,6,6)
15. MID(“The sum of twelve and twenty is thirty-two.”,12,10)
16. Suppose the string “11/20/22 The Pillow Store \$76.34” is in cell A5. What will the function MID(A5,10,FIND(“\$”,A5)-10) return?
17. Suppose the string “051121 Okra Express \$76.34” is in cell B3. What will the function MID(B3,8,FIND(“\$”,B3)-8) return?

Use the provided pivot table to answer the questions.

18. The following pivot table displays a partial inventory of a clothing store, where the columns indicate the season the item of clothing is intended for.

Style and Color	Fall	Spring	Winter	Grand Total
<b>Cardigan</b>		<b>28</b>		<b>28</b>
Blue		8		8
Ivory		10		10
Pink		9		9
Purple		1		1
<b>Coat</b>	<b>14</b>		<b>14</b>	<b>28</b>
Black	6		5	11
Blue	4		4	8
Green	4		5	9
<b>Jacket</b>	<b>23</b>	<b>22</b>		<b>45</b>
Black	12	7		19
Blue	6	7		13
Gray	5	8		13
<b>Grand Total</b>	<b>37</b>	<b>50</b>	<b>14</b>	<b>101</b>

- a. What is the total inventory of each type of clothing?
- b. Which seasons are the clothing items intended for?
- c. What color cardigans are in stock?
- d. How many items in stock are intended for spring?

19. The following pivot table displays a summary of houses that are listed for sale by a real estate agent, where the columns indicate the number of bathrooms the house has.

Style and Bedrooms	1	2	2.5	Grand Total
<b>Cape Cod</b>	<b>16</b>	<b>24</b>		<b>40</b>
2		4		4
3		12	18	30
4			6	6
<b>Colonial</b>	<b>3</b>	<b>24</b>	<b>5</b>	<b>32</b>
2		2	1	3
3		1	13	14
4			10	15
<b>Farmhouse</b>	<b>6</b>	<b>14</b>		<b>20</b>
2		2		2
3		4	12	16
4			2	2
<b>Ranch</b>	<b>10</b>	<b>18</b>		<b>28</b>
2		2		2
3		8	12	20
4			6	6
<b>Grand Total</b>	<b>35</b>	<b>80</b>	<b>5</b>	<b>120</b>

- What styles of house are listed as for sale by this real-estate agent?
- How many Cape Cod style houses listed for sale have three bedrooms?
- How many houses listed for sale have two bathrooms?
- How many farmhouses are listed for sale?

20. The following spreadsheet is comprised of two tables containing order and customer information for an online art store. Determine the identifier that should be used to join these data tables together using the LOOKUP function in Excel.

	A	B	C	D	E	F	G
1	<b>Order Information</b>				<b>Customer Information</b>		
2	Online Request	ID	Item		ID	Name	Sign-up Date
3	202	1939	Kittens		1159	Abigail Berry	01-09-2020
4	203	1321	Flowers		1752	Adam Diaz	02-12-2019
5	204	1551	Springtime		1099	Ali Richardson	14-04-2020
6	205	1304	Kittens		1337	Daniel King	10-06-2018
7	206	1882	Ducks		1919	Jade Davis	12-02-2020
8	207	1099	Nighttime		1939	James Knight	05-04-2019
9	208	1182	Dusk		1321	Liam Smith	17-05-2020
10	209	1159	Eclipse		1551	Martha MacDonnell	02-11-2018
11	210	1529	Sunset		1529	Mira Ward	29-03-2021
12	211	1752	Flowers		1882	Olivia Skywell	11-08-2019
13	212	1337	Nighttime		1182	Omar Torres	12-02-2021
14	213	1919	Eclipse		1304	Skylar Davis	25-12-2021

21. The following partial spreadsheet is comprised of two tables containing book inventory and author information for an online bookstore. Determine the identifier that should be used to join these data tables together using the LOOKUP function in Excel.

	A	B	C	D	E	F	G
1	Inventory				Author Information		
2	Inventory ID	Price	Book Title		Author ID	Author	Book Title
3	175946854	15.99	Attack at Dusk		27789	L.M. Queen	Glossary of Slant Rhymes
4	175946855	14.79	A Speck of Thyme		27790	Niane Luffhaus	Attack at Dusk
5	175946856	12.99	Glossary of Slant Rhymes		27791	Patricia L. Black	A Midnight Meeting
6	175946857	14.99	Whining over Wine		27792	Kristine Phantom	A Sunset of Sparks
7	175946858	15.59	A Midnight Meeting		27793	T. Lewis Walsh	Return to Sender
8	175946859	13.99	A Chance of Snow		27794	Elena Miller	Whining over Wine
9	175946860	12.99	Last Year's Mistake		27795	Sophia M. Chen	A Chance of Snow
10	175946861	14.99	The Two Faces of Torrance		27796	L. Noah Song	A Speck of Thyme
11	175946862	15.99	Return to Sender		27797	Maxim Mandal	The Dashing Duchess
12	175946863	15.99	A Sunset of Sparks		27798	Alexander C. Ghosh	Last Year's Mistake
13	175946864	15.99	Where the River Ends		27799	Tomas Williams	Where the River Ends
14	175946865	15.99	The Dashing Duchess		27800	John Mark Castillo	The Two Faces of Torrance

 **WRITING & THINKING**

22. Explain why it would be useful to have two different pivot tables of the same data set in a presentation.

# 12.3 Exercises

## ✓ CONCEPT CHECK

1. A scatter plot is a graph that shows the \_\_\_\_\_ between two variables.
2. When data points in a scatter plot appear to follow an upward trend, there is a \_\_\_\_\_ linear correlation between the variables.
3. Once the relationship between two variables is determined to be statistically significant, a \_\_\_\_\_ can be fit to the data set to model the situation.
4. True or False: The Pearson correlation coefficient is always a positive value.
5. True or False: The level of confidence is the probability that assertions made about the data are incorrect.

## 🔑 PRACTICE

Use the linear regression model  $\hat{y} = ax + b$  to predict the  $y$ -value for each value of  $x$ .

- |                               |                                |
|-------------------------------|--------------------------------|
| 6. $\hat{y} = 28.01x + 17.83$ | 7. $\hat{y} = -16.5x + 230.55$ |
| a. $x = 21$                   | a. $x = 5$                     |
| b. $x = 31$                   | b. $x = 13$                    |
| c. $x = 40$                   | c. $x = 35$                    |

In each scatter plot, determine whether there appears to be a positive linear correlation, a negative linear correlation, or no linear correlation.

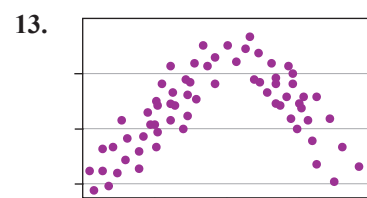
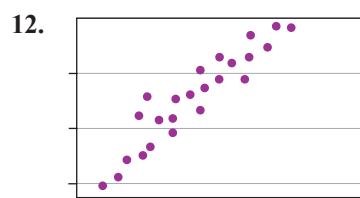
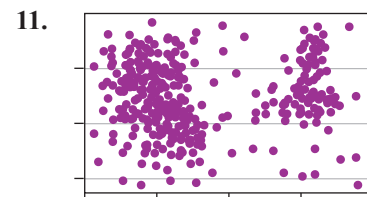
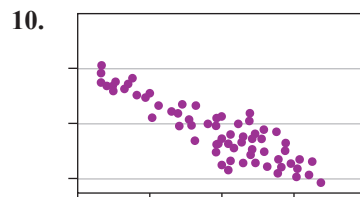
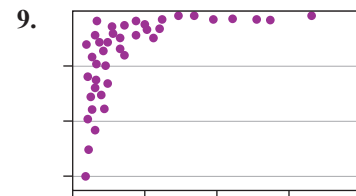
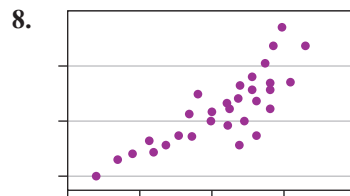

Consider each set of variables and predict whether the variables would have a weak negative relationship, a strong negative relationship, a weak positive relationship, a strong positive relationship, or no relationship at all.

14. Body weight and hours of exercise per week
15. A person's height and their self-esteem
16. Vision ability and IQ
17. Number of hours spent studying for a test and the grade on the test

Determine whether each correlation coefficient is statistically significant at the specified level of significance for the given sample size.

18.  $r = 0.703$ ,  $\alpha = 0.01$ ,  $n = 12$
19.  $r = 0.403$ ,  $\alpha = 0.05$ ,  $n = 25$
20.  $r = 0.378$ ,  $\alpha = 0.05$ ,  $n = 29$
21.  $r = 0.809$ ,  $\alpha = 0.01$ ,  $n = 8$

For each data set, find the following.

- a. Estimate the correlation in words as positive, negative, or no correlation.
  - b. Calculate the correlation coefficient  $r$ . Round your answer to the nearest thousandth, if necessary.
  - c. Determine whether  $r$  is statistically significant at the 0.01 level of significance.
22. The following table gives the number of hours a student watches TV per week and his or her overall GPA.

<b>TV Hours</b>	20	10	25	15	14	13	21	9	5
<b>GPA</b>	2.0	2.46	2.3	2.9	3.0	3.2	3.5	3.3	3.7

23. The following table gives a sample of annual income and number of years of education.

<b>Annual Income</b>	\$21,000	\$39,000	\$40,000	\$39,500	\$42,000	\$55,500
<b>Years of Education</b>	12	12	14	16	16	16
<b>Annual Income</b>	\$61,000	\$45,000	\$100,000	\$142,000	\$240,000	\$205,000
<b>Years of Education</b>	17	16	16	20	22	21

24. The following table shows the diastolic blood pressure reading and the stress test score for 20 adults.

<b>Blood Pressure Reading and Stress Test Score</b>	
<b>Stress Test Score</b>	<b>Diastolic Blood Pressure Reading</b>
51	67
59	66
62	71
63	76
64	73
68	77
71	77
70	76
72	80
82	82
78	79
79	83
83	81
84	83
88	85
87	90
89	82
91	80
90	86
90	88

25. The following table shows the heights of identical twins in centimeters.

<b>Heights of Identical Twins</b>	
<b>Sibling 1</b>	<b>Sibling 2</b>
110.5	109.5
116.6	115.6
122.6	121.6
128.2	127.4
133.5	133.5
138.8	140.2
145.0	146.7
152.3	151.9
159.6	155.0
165.1	156.6
168.3	157.1
169.9	157.6
170.7	158.0

 APPLICATIONS

Use the provided table to create a scatter plot of the data. Remember to label both axes as well as the graph itself. Describe whether the scatter plot indicates there appears to be a positive linear correlation, negative linear correlation, or no correlation.

26. Allied Technologies is trying to determine how well the different locations are utilizing the TFS system to track their work. The following table shows the data collected regarding the number of employees and the approximate percentage of their workload that had been accounted for in TFS.

**Sample of TFS Usage by Allied Technologies**

<b>Number of Employees</b>	12	8	15	16	9	11	7	13
<b>% of Workload Accounted for in TFS</b>	76	64	85	88	67	73	61	79

27. A group of hikers decided to record the temperature at various heights along their climb. Consider the following data they collected regarding their height above sea level and the temperature.

**Sample of Temperatures at Different Elevations**

<b>Height Above Sea Level (m)</b>	500	800	1000	2000	1500	3000	1200	2500
<b>Temperature (°C)</b>	26	25	24	14	20	10	23	15

28. Casandra made several trips from college to home. She often brought friends which meant additional luggage as well. She has been keeping track of her fuel consumption. The following table shows the approximate additional weight per trip and the fuel consumption in miles per gallon.

**Sample of Fuel Consumption per Trip**

<b>Additional Weight in Vehicle (lb)</b>	500	1000	750	600	850	900
<b>Fuel Consumption (Miles per Gallon)</b>	45	42	43	44	42	43

29. Melissa started exercising for 30 minutes per day and she recorded her weight every morning for a week, as shown in the following table.

**Sample of Weight per Day**

<b>Day</b>	1	2	3	4	5	6
<b>Weight (lb)</b>	178	177	178	176	179	177

30. The following table gives the data for the number of months students have taken piano lessons and the number of songs they can play from memory.

# of Months	0	5	3	10	22	19	30	15	8	12
# of Songs	1	4	0	5	9	12	10	0	4	9

- Determine the regression line  $\hat{y} = ax + b$ . Round the slope and  $y$ -intercept to the nearest thousandth.
  - Determine if the regression equation is appropriate, at the 0.05 level of significance, to use for making predictions. If so, answer part c.
  - If a student has taken eight months of piano lessons, make a prediction for the number of songs they can play from memory, if appropriate.
31. The following table shows students' test grades on the first two tests in an introductory literature class.

Test 1 ( $x$ )	61	45	71	81	89	55	84	91	95	59	77	88
Test 2 ( $y$ )	67	79	68	80	87	68	87	90	97	71	77	74

- Determine the regression line  $\hat{y} = ax + b$ . Round the slope and  $y$ -intercept to the nearest thousandth.
  - Determine if the regression equation is appropriate, at the 0.05 level of significance, to use for making predictions. If so, answer part c.
  - If a student scored a 70 on his first test, make a prediction for his score on the second test, if appropriate.
32. The following shows the results on evaluations measuring self-esteem and perceived family support from 10 adolescents.

Self-Esteem	30	31	31	28	27	26	15	32	27	33
Family Support	13	13	19	21	8	4	10	12	7	17

- Determine the regression line  $\hat{y} = ax + b$ . Round the slope and  $y$ -intercept to the nearest thousandth.
- Determine if the regression equation is appropriate, at the 0.05 level of significance, to use for making predictions. If so, answer part c.
- If an adolescent had a self-esteem score of 22, make a prediction for his perceived family support score, if appropriate.

33. A medical equipment company wishes to show that a new device works with the same degree of accuracy and precision as an earlier model to perform an electrocardiogram. One of the measurements tested was the change in radio electric waves during a cardiac cycle. The following results were collected from both healthy adults and those with cardiovascular problems.

Change in Radio Electric Waves During Cardiac Cycle	
# of 5 mm Squares Between R Waves	
Old	New
2	2
3	3
4	4.5
3	3
6	6
4	4.5
3	3
5	5
3	3.5
2	2
6	6
4	4
6	6
5	5
3	3
2	2

- Determine the regression line  $\hat{y} = ax + b$ . Round the slope and  $y$ -intercept to the nearest thousandth.
- Determine if the regression equation is appropriate, at the 0.01 level of significance, to use for making predictions. If so, answer part c.
- If the old machine had a reading of 5.5, make a prediction for the new machine reading, if appropriate.





14. Which salesperson made the most sales during the quarter?
15. Which salesperson acquired the most new clients during the quarter?
16. Compare the success of Williams and Akter.

The following bubble chart summarizes the success of social media posts by an online store in regards to shares and resulting website visits. The size of the bubbles represents the total number of sales made as the result of the post. Use the bubble chart to answer the questions.

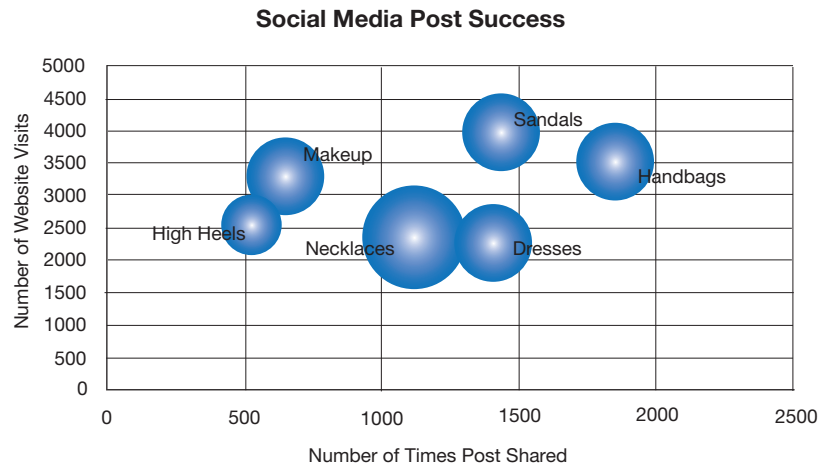

17. Which social media post topic was the most successful in terms of sales?
18. Which social media post topic was the most successful in terms of shares?
19. Which social media post was least successful in terms of website visits?
20. Based on this bubble chart, can a conclusion be drawn that a high number of shares or a high number of website visits translates into a high number of sales? Explain your reasoning.

The following infographic shows the marriage rates in the United States by state compared to the national average as reported by the United States Census Bureau. Use the infographic to answer the following questions<sup>6</sup>.

### State Marriage and Divorce Rates Compared to National Rate: 2018

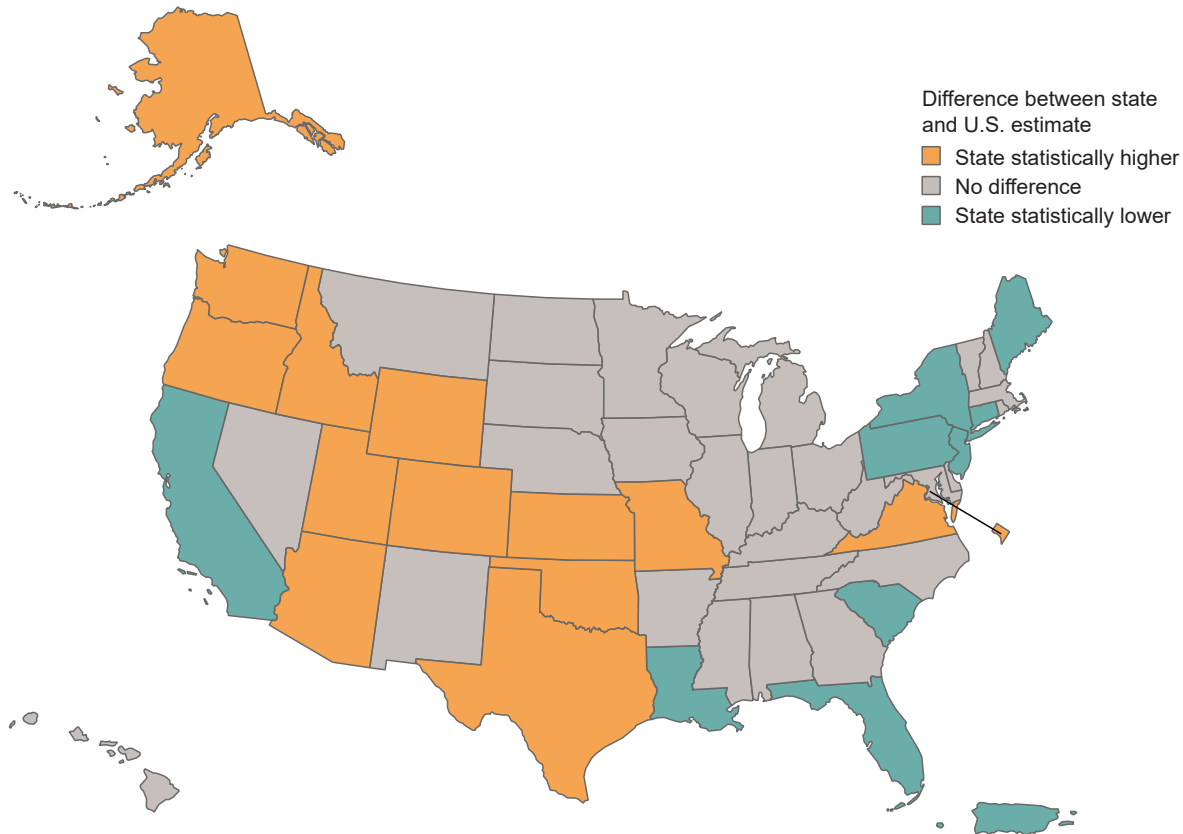

21. Does the infographic convey that the marriage rate in most states in the United States is higher than, lower than, or no different than the national average?
22. Can the infographic be used to illustrate specific differences in marriage rates among different individual states in the United States? Explain why or why not.
23. Suppose a campaign wanted to use this infographic to show that marriage rates are lower in popular tourist destinations. What additional information could be added to tell this story?

A sales firm has the following dashboard displayed in their office to show success during the current quarter. Use the dashboard to answer the following questions.

24. Describe the main information displayed in the dashboard.
25. According to the Weekly Sales table, which customer base made up the majority of sales during the quarter? Explain your reasoning.

<sup>6</sup> U.S. Marriage and Divorce Rates by State: 2008 & 2018," United States Census Bureau, January 15, 2020, <https://www.census.gov/library/visualizations/interactive/marriage-divorce-rates-by-state.html>.

- 26. How could you change the Top Sales portion so that it tells a better story?
- 27. List ways that the dashboard could be improved to tell a better story of how well the company is doing overall.

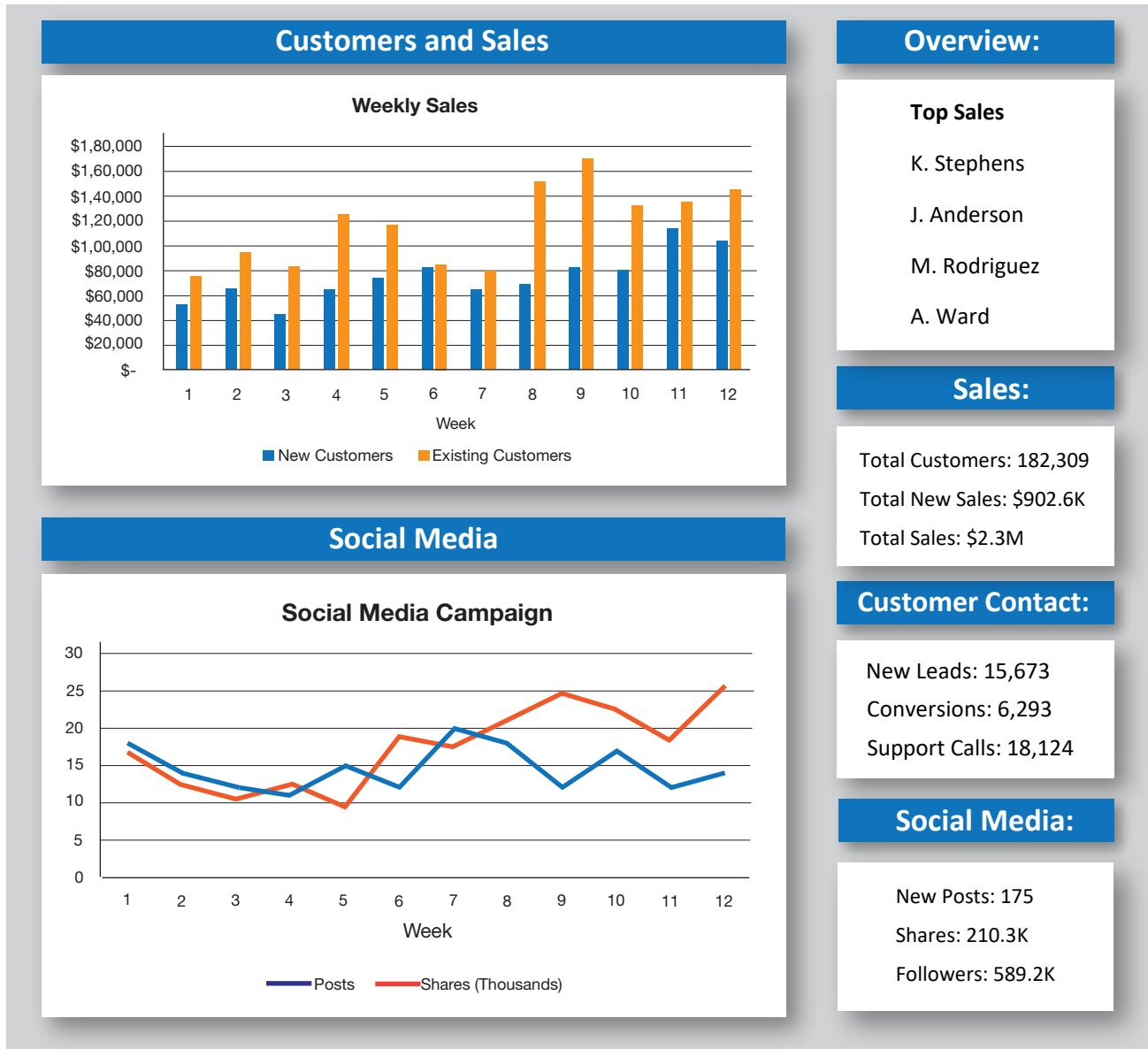

**Plurality with Elimination**

A series of runoff elections, or eliminations, where the candidate with the least amount of first-place votes is removed from the ballot each round. A winner is declared when a candidate has a majority of the first-place votes.

**Pairwise Comparison**

Every candidate is compared head-to-head with the other candidates. In each pair of comparisons, the candidate with the greater number of higher rankings is given a point. The candidate with the most points after all head-to-head comparisons are made is the winner.

**Skill Check Answer**

1. Sydney, with 53 votes that gave her a fifth place ranking.

## 13.1 Exercises

### ✓ CONCEPT CHECK

1. The \_\_\_\_\_ method of choosing a winner in an election is a single vote with a winner-take-all approach. The winner need not have a majority of the votes to win; she just needs the most votes.
2. The \_\_\_\_\_ method for elections pits each candidate against all of the others individually in order to choose a winner.
3. Setting up an election so that voters are required to rank all the candidates requires use of a \_\_\_\_\_.
4. In order to give weight to each of the different rankings for candidates, the \_\_\_\_\_ attributes each ranking a certain number of points, and the candidate with the most points wins the election.
5. In a \_\_\_\_\_ election, the winner must receive more than 50% of the votes.

### 💡 PRACTICE

Create a preference table to show the results for each set of preference ballots.

6. Candidates in the election are: Maria, Daniel, Eisa.

Maria, Eisa, Daniel: 29

Eisa, Daniel, Maria: 43

Eisa, Maria, Daniel: 33

Daniel, Maria, Eisa: 17

Maria, Daniel, Eisa: 3

Daniel, Eisa, Maria: 21

7. The candidates are: Lars, Noah, Stephen, Oliver, Jack.  
 Stephen, Oliver, Jack, Lars, Noah: 212  
 Noah, Oliver, Jack, Lars, Stephen: 133  
 Oliver, Stephen, Jack, Noah, Lars: 543  
 Jack, Stephen, Lars, Noah, Oliver: 24  
 Oliver, Noah, Lars, Jack, Stephen: 179  
 Noah, Lars, Stephen, Jack, Oliver: 8  
 Stephen, Lars, Oliver, Noah, Jack: 201  
 Stephen, Jack, Lars, Noah, Oliver: 11
8. The candidates are: Jones (J), Brown (B), Wang (W), Cohen (C), Diaz (D).  
 JBDCW, CWJDB, WBDJC, BDCWJ, JBDCW, JBDCW, CWJDB,  
 CWJDB, WBDJC, JBDCW, BWJDC, WBDJC, CWJDB, BWJDC,  
 BWJDC, BJWCD, WBDJC, BWJDC, JBDCW, BJWCD, WBDJC,  
 BWJDC, JBDCW, JBDCW, DBWCJ
9. Candidates in the election are: Nguyen (N), Dey (D), Smith (S), Mori (M),  
 Abbadì (A).  
 MADNS, NDSMA, DSMAN, SMAND, SMAND, NDSMA, MANDS,  
 DSMAN, SAMND, NDSMA, SMAND, NDSMA, MANDS, SAMND,  
 NDSMA, MANDS, MANS D, SDMAN, MADNS, MANDS, MANDS,  
 SMAND, NDSMA, DSMAN, SAMDN, MADNS, SAMDN, SMAND,  
 SMAND, NDSMA

Use the given preference table to answer each question.

10. Answer the following questions about the given preference table.

Preference Table for Candidates					
Rankings					
<b>1st</b>	A	C	C	E	E
<b>2nd</b>	B	E	E	D	A
<b>3rd</b>	C	B	A	B	C
<b>4th</b>	E	D	B	C	D
<b>5th</b>	D	A	D	A	B
<b>Total Votes</b>	<b>153</b>	<b>129</b>	<b>63</b>	<b>404</b>	<b>111</b>

- How many possible unique rankings are there of the candidates in the election?
- How many people voted in the election?
- How many voters place Candidate C in first place?
- Which candidate wins using the plurality method?
- How many votes would a candidate need to have a majority?
- Do any of the candidates have a majority of first-place votes?

11. A wedding planning website asked visitors to rank the following six all-time favorite wedding songs. The song choices are *Nothing Compares to You* by Sinead O’Connor, *Love Me Tender* by Elvis Presley, *Close to You* by Maxi Priest, *When You Say Nothing at All* by Ronan Keating, *Just the Way You Are* by Billy Joel, and *You Made Me Love You* by Al Jolson. Use the preference table to answer the questions.

Rankings				
<b>1st</b>	Presley	Priest	O’Connor	Keating
<b>2nd</b>	Jolson	O’Connor	Presley	Joel
<b>3rd</b>	Keating	Joel	Priest	Presley
<b>4th</b>	Priest	Jolson	Keating	O’Connor
<b>5th</b>	Joel	Presley	Joel	Jolson
<b>6th</b>	O’Connor	Keating	Jolson	Priest
<b>Total Votes</b>	<b>1320</b>	<b>2010</b>	<b>3167</b>	<b>2697</b>

- How many possible unique rankings are there of the six wedding songs?
- How many people participated in the website questionnaire?
- Which song was ranked number one by the most voters?
- How many votes are required for a song to have a majority of first-place votes?
- Do any of the songs have a majority of first-place votes?

Complete each preference table.

12. The student programming board is deciding which band to bring to campus for a student concert. The possibilities are Matisyahu, Lady A, and The Black Keys. Complete the following preference table so that The Black Keys win the election using the majority rule.

Rankings			
<b>1st</b>	The Black Keys	Lady A	Matisyahu
<b>2nd</b>	Lady A	Matisyahu	The Black Keys
<b>3rd</b>	Matisyahu	The Black Keys	Lady A
<b>Total Votes</b>	<b>?</b>	<b>9</b>	<b>2</b>

13. A hospital needs a new doctor. The hiring committee wants to get feedback from the current staff. They have the nursing staff and resident doctors rank the candidates in order of their preference. Complete the following preference table so that Perez is the staff's top choice using the plurality method.

Preference Table for New Doctor				
Rankings				
<b>1st</b>	Ross	Porter	Walker	Perez
<b>2nd</b>	Perez	Walker	Ross	Porter
<b>3rd</b>	Walker	Perez	Perez	Ross
<b>4th</b>	Porter	Ross	Porter	Walker
<b>Total Votes</b>	<b>?</b>	<b>21</b>	<b>22</b>	<b>36</b>

14. Phonetex is trying to decide which new feature to include in an advertising campaign: 12 megapixel camera, longer battery life, voice-activated commands, or reception quality. The company surveyed its current customers and asked them to rank the four features in order of preference. Complete the following preference table so that voice-activated commands is the favorite among current customers using the plurality with elimination method.

Preference Table for New Features				
Rankings				
<b>1st</b>	Camera	Battery Life	Voice-Activated	Voice-Activated
<b>2nd</b>	Reception Quality	Reception Quality	Reception Quality	Camera
<b>3rd</b>	Battery Life	Voice-Activated	Camera	Reception Quality
<b>4th</b>	Voice-Activated	Camera	Battery Life	Battery Life
<b>Total Votes</b>	<b>44</b>	<b>11</b>	<b>?</b>	<b>56</b>

15. Rhone County is electing a new county executive. The candidates are McMillian, Witt, and Longsdon. Complete the following preference table so that McMillian wins the election using the Borda count method.

Preference Table for Candidates			
Rankings			
<b>1st</b>	?	Witt	McMillian
<b>2nd</b>	?	McMillian	Longsdon
<b>3rd</b>	McMillian	Longsdon	Witt
<b>Total Votes</b>	<b>601</b>	<b>632</b>	<b>650</b>

16. *College Living Magazine* is compiling a list of the top five features of a college or university that students used when choosing an institution for higher education. They asked students to rank the importance of the following features of colleges and universities: size of the school, strength of the degree program, location, and number of student activities. Complete the following preference table so that location is the top influencer among students if the pairwise method of comparison is used.

Preference Table for Most Important Features					
		Rankings			
<b>1st</b>	Size	Location	Activities	Size	Strength
<b>2nd</b>	Activities	Strength	Size	Location	Activities
<b>3rd</b>	Strength	Size	Location	Strength	Location
<b>4th</b>	Location	Activities	Strength	Activities	Size
<b>Total Votes</b>	<b>100</b>	<b>?</b>	<b>55</b>	<b>105</b>	<b>89</b>

Calculate the number of pairwise comparisons that must be made in each election.

17. In the history club on campus, five students are running for the office of president.
18. Running for president of the National Association of College Students are the following students: L. Mayer, R. Schartz, M. Gillmore, L. Bilbo, R. Rosevear, K. Colletta, T. Yawn, S. Oswald, and K. Smith.

### APPLICATIONS

19. The following table shows the number of votes for first, second, and third places that the top five college football players received in 2011 for the Heisman Trophy—College Football’s highest award. Determine the number of total points that each player would receive using the Borda count method if a first place vote receives 3 points, a second place receives 2 points, and third place receives 1 point.

Preference Table for 2011 Heisman Trophy Candidates				
Player	School	1st	2nd	3rd
Robert Griffin III	Baylor	405	168	136
Andrew Luck	Stanford	247	250	166
Trent Richardson	Alabama	138	207	150
Montee Ball	Wisconsin	22	83	116
Tyrann Mathieu	Louisiana State	34	63	99

**Source:** Heisman Trophy. "2011 - 77th Award Robert Griffin III Baylor University." <https://www.heisman.com/heisman-winners/robert-griffin-iii/>

20. In professional baseball, the Baseball Writers' Association of America hands out two Most Valuable Player (MVP) awards each year. One for the American League and one for the National League. The following table shows the voting breakdown for the top 10 players in the National League. Determine the number of total points that each player received using the Borda count method, given that a first place vote receives 14 points, a second place receives 9 points, third place receives 8 points, and on down to 1 point for tenth place.

National League MVP 2011											
Player	Team	1st	2nd	3rd	4th	5th	6th	7th	8th	9th	10th
Ryan Braun	Milwaukee Brewers	20	12								
Matt Kemp	Los Angeles Dodgers	10	16	6							
Prince Fielder	Milwaukee Brewers	1	4	11	9	1	3		2		1
Justin Upton	Arizona Diamondbacks	1		8	11	6	3	1	1		1
Albert Pujols	St. Louis Cardinals			1	6	11	6	4		2	
Joey Votto	Cincinnati Reds			4	3	2	8	3	3	4	1
Lance Berkman	St. Louis Cardinals			1	2	6	3	7	2	4	3
Troy Tulowitzki	Colorado Rockies						3	4	8	5	4
Roy Halladay	Philadelphia Phillies			1		1	1	6	2		3
Ryan Howard	Philadelphia Phillies				1	3	1	1		1	3

**Source:** Baseball Writers' Association of America. "2011 NL MVP: Ryan Braun Slugs His Way to Award." <https://bbwaa.com/11-nl-mvp/>

21. In an attempt to choose a list of the "Best Places to Live in America," readers of a magazine were asked to rank eight towns. The following preference table summarizes the results of the survey.

Preference Table for Best Places to Live in America					
Rankings					
<b>1st</b>	Louisville, CO	Middleton, WI	Leesburg, VA	Leesburg, VA	Hanover, NH
<b>2nd</b>	Papillion, NE	Louisville, CO	Middleton, WI	Milton, MA	Leesburg, VA
<b>3rd</b>	Hanover, NH	Liberty, MO	Milton, MA	Louisville, CO	Milton, MA
<b>4th</b>	Milton, MA	Milton, MA	Liberty, MO	Papillion, NE	Solon, OH
<b>5th</b>	Liberty, MO	Papillion, NE	Hanover, NH	Solon, OH	Middleton, WI
<b>6th</b>	Solon, OH	Solon, OH	Papillion, NE	Hanover, NH	Papillion, NE
<b>7th</b>	Middleton, WI	Leesburg, VA	Solon, OH	Middleton, WI	Louisville, CO
<b>8th</b>	Leesburg, VA	Hanover, NH	Louisville, CO	Liberty, MO	Liberty, MO
<b>Total Votes</b>	<b>345</b>	<b>231</b>	<b>211</b>	<b>202</b>	<b>16</b>

- Determine a winner using the plurality method.
- Determine a winner using the plurality with elimination method.
- Which method do you think chooses the winner that best reflects the votes, or would you choose a different method? Explain your answer.

22. The following preference table summarizes the election results for city mayor of Clamptonville.

Rankings				
<b>1st</b>	Costa	Little	Little	Torres
<b>2nd</b>	Braugh	Allen	Costa	Braugh
<b>3rd</b>	Little	Torres	Braugh	Allen
<b>4th</b>	Torres	Braugh	Allen	Little
<b>5th</b>	Allen	Costa	Torres	Costa
<b>Total Votes</b>	<b>1231</b>	<b>542</b>	<b>1001</b>	<b>654</b>

- Determine the winner for city mayor using the Borda count method.
  - Determine the winner for city mayor using the plurality with elimination method.
  - Determine the winner with the pairwise method of comparison.
  - Suppose that Braugh withdrew from the race before the votes were counted. Candidates ranked below him in any of the orders simply move up a ranking. Who would be declared the winner using the Borda count method with the new preference table? Is this a different winner than in part a.?
23. A university’s Department of Business is electing a new chairman. As part of the process, each candidate gives a brief question and answer session with the business students. The students are then asked to rank the candidates in order of preference. The following table shows the results of the student votes.

Rankings						
<b>1st</b>	B	A	C	C	D	B
<b>2nd</b>	A	B	D	B	A	A
<b>3rd</b>	D	C	B	D	B	C
<b>4th</b>	C	D	A	A	C	D
<b>Total Votes</b>	<b>43</b>	<b>12</b>	<b>13</b>	<b>21</b>	<b>51</b>	<b>9</b>

- Determine the student preference for chairman by using the pairwise method of comparison.
- Determine the student preference for chairman by using the plurality with elimination method.
- Determine the student preference for chairman by using the plurality method.
- If you were chosen to represent the students by announcing a preference for chairman, which candidate would you recommend? How would you defend your choice based on the answers to a.–c.?

24. The Tennessee Department of Transportation is considering a new bus route between its state capital, Nashville, and one of the other four largest cities: Knoxville, Memphis, Chattanooga, and Clarksville. Each of the 99 State Representatives was asked to rank the cities in order of preference for the new route. Their votes are summarized in the following table.

Preference Table for New Bus Route						
Rankings						
<b>1st</b>	Chattanooga	Memphis	Chattanooga	Knoxville	Clarksville	Memphis
<b>2nd</b>	Memphis	Knoxville	Clarksville	Memphis	Knoxville	Knoxville
<b>3rd</b>	Clarksville	Clarksville	Knoxville	Chattanooga	Memphis	Chattanooga
<b>4th</b>	Knoxville	Chattanooga	Memphis	Clarksville	Chattanooga	Clarksville
<b>Total Votes</b>	<b>23</b>	<b>13</b>	<b>9</b>	<b>33</b>	<b>12</b>	<b>9</b>

- Which city would receive the new bus route using the pairwise method of comparison?
  - Which city received the most first-place votes? Is this a majority?
  - Which city would receive the new bus route using the plurality with elimination method?
  - Which city would receive the new bus route using the Borda count method?
  - Explain which method you think is most “fair” in choosing the new bus route.
25. In the 1968 United States Presidential Election, three candidates shared most of the November 5 popular vote, although there was a small portion of votes for other candidates. The following table displays the breakdown of the popular vote along with the electoral vote for the election.

1968 US Presidential Election Results			
Presidential Candidate	Popular vote		Electoral Vote
	Count	Percentage	
Richard Milhous Nixon	31,783,783	43.40%	301
Hubert Horatio Humphrey	31,271,839	42.70%	191
George Corley Wallace	9,901,118	13.50%	46
Eugene McCarthy	25,634	0.00%	0
Other	217,624	0.30%	0
<b>Total Votes</b>	<b>73,199,998</b>		<b>538</b>

Sources: 1968 Presidential General Election Results, <http://www.uselectionatlas.org>. Electoral Votes for President and Vice President, <http://www.archives.gov>.

- Who won the popular vote by plurality? Was it a majority?
- Who won the electoral vote by plurality? Was it a majority?
- Compare the outcomes of the popular vote between Nixon and Humphrey to that of the electoral vote for the two candidates.
- Suppose Wallace had dropped out of the election. Is it possible that Humphrey would have won the presidency? Explain your answer.

The following table summarizes each of the voting methods discussed previously versus the fairness criteria used in democratic elections.

**Table 13.2.16:** Voting Methods and Fairness Criteria

	Condorcet Criterion	Majority Criterion	Monotonicity Criterion	Irrelevant Alternatives Criterion	Dictator Criterion
<b>Majority Rule Decision</b>	Never violates	Never violates	Never violates	Never violates	May violate
<b>Plurality</b>	May violate	Never violates	Never violates	May violate	Never violates
<b>Borda Count</b>	May violate	May violate	Never violates	May violate	Never violates
<b>Plurality with Elimination</b>	May violate	Never violates	May violate	May violate	Never violates
<b>Pairwise Comparison</b>	Never violates	Never violates	Never violates	May violate	Never violates

As our table shows, it would appear that using a majority rule as an election method might in fact be the perfect voting system because it never violates any of the four fairness criteria in a democracy. However, the one “fly in the ointment,” so to say, is exactly what we saw in the previous section—using the majority rule doesn’t always produce a winner. This is why Arrow requires that valid voting systems always produce a distinct winner.

## 13.2 Exercises

### ✓ CONCEPT CHECK

1. The \_\_\_\_\_ states that if a candidate wins the head-to-head comparison—as in the pairwise comparison method—against every other candidate, then that candidate should also win the overall election in a fair voting system.
2. If a candidate receives a majority of votes in an election but does not win, the \_\_\_\_\_ has been violated.
3. The \_\_\_\_\_ requires that if Candidate X wins an election, then X would also win a second election if each voter were allowed to reorder the candidates in such a way that X only increases in ranking while the order of the other candidates remained the same.
4. If the winner of an election is changed when one or more candidates drops out of the election, the \_\_\_\_\_ has been violated.
5. The \_\_\_\_\_ is the only voting method that can violate the majority criterion.

 APPLICATIONS

Use the given preference table to answer each question.

6. A group of students were asked to listen to auditions by four bands for the homecoming dance and then rank the bands. The following preference table summarizes their selections.

Preference Table for Homecoming Bands					
Rankings					
<b>1st</b>	Band B	Band A	Band C	Band D	Band A
<b>2nd</b>	Band D	Band D	Band B	Band A	Band C
<b>3rd</b>	Band C	Band B	Band A	Band B	Band B
<b>4th</b>	Band A	Band C	Band D	Band C	Band D
<b>Total Votes</b>	<b>23</b>	<b>15</b>	<b>16</b>	<b>11</b>	<b>5</b>

- Which band is the plurality winner?
  - Which candidate wins the election using a pairwise method of comparison?
  - Does this election, using the plurality method, satisfy the Condorcet criterion? Explain your answer.
7. Susan, Courtney, and Jade ran for Freshman SGA representative. The following preference table shows the results of the race.

Preference Table for SGA Representatives			
Rankings			
<b>1st</b>	Susan	Courtney	Susan
<b>2nd</b>	Courtney	Susan	Jade
<b>3rd</b>	Jade	Jade	Courtney
<b>Total Votes</b>	<b>32</b>	<b>55</b>	<b>16</b>

- Which candidate is the winner using the Borda count method?
- Which candidate is the winner using the pairwise method of comparison?
- Does the Borda count method satisfy the Condorcet criterion in this situation? Why or why not?

8. Work colleagues are trying to decide on which restaurant to use for their end-of-year party. Since they don't all agree on a favorite, they decide to rank the four possibilities and decide on a restaurant that way. The results are shown in the preference table.

Preference Table for Favorite Restaurants					
Rankings					
<b>1st</b>	Tanvi's	O'Reilly's Pub	Ralphie's	Tanvi's	Salty's
<b>2nd</b>	Ralphie's	Salty's	Tanvi's	O'Reilly's Pub	Ralphie's
<b>3rd</b>	Salty's	Tanvi's	Salty's	Salty's	O'Reilly's Pub
<b>4th</b>	O'Reilly's Pub	Ralphie's	O'Reilly's Pub	Ralphie's	Tanvi's
<b>Total Votes</b>	<b>8</b>	<b>3</b>	<b>4</b>	<b>11</b>	<b>9</b>

- Which restaurant is the winner using the plurality with elimination method?
  - Which restaurant is the winner using the pairwise method of comparison?
  - Does the plurality with elimination method satisfy the Condorcet criterion if the colleagues chose a restaurant using plurality with elimination? Why or why not?
9. Jack is scheduling classes for next semester and has three possible classes for a particular time slot. He surveys students to see which class has the most interest out of Electricity and Magnetism, Heat and Optics, and Mechanics.

Preference Table for Classes				
Rankings				
<b>1st</b>	H & O	Mechanics	H & O	E & M
<b>2nd</b>	E & M	H & O	E & M	Mechanics
<b>3rd</b>	Mechanics	E & M	Mechanics	H & O
<b>Total Votes</b>	<b>81</b>	<b>132</b>	<b>36</b>	<b>13</b>

- Which class has the most interest using the majority rule?
- Which class has the most interest using the Borda count method?
- Does the Borda count method satisfy the majority criterion if Jack uses this method to fill the available time slot? Explain your answer.

10. The history department is adopting a new textbook for the Freshman Introduction class. Instructors in the history department were asked to rank the top four textbooks in order of usability for the class. The preference table shows the outcome of their rankings.

Preference Table for History Textbooks				
Rankings				
<b>1st</b>	<i>Excursions Through Time</i>	<i>Thinking Historically</i>	<i>A Look in Time</i>	<i>Through the Ages</i>
<b>2nd</b>	<i>Thinking Historically</i>	<i>A Look in Time</i>	<i>Thinking Historically</i>	<i>A Look in Time</i>
<b>3rd</b>	<i>A Look in Time</i>	<i>Excursions Through Time</i>	<i>Through the Ages</i>	<i>Thinking Historically</i>
<b>4th</b>	<i>Through the Ages</i>	<i>Through the Ages</i>	<i>Excursions Through Time</i>	<i>Excursions Through Time</i>
<b>Total Votes</b>	<b>7</b>	<b>3</b>	<b>7</b>	<b>4</b>

- Use the plurality with elimination method to choose a new textbook for adoption.
  - After some discussion in the department, the seven instructors whose rankings appear in the first column decide to change their votes so that the textbooks titled *A Look in Time* and *Thinking Historically* swap rankings. Create a new preference table to show this change and then use the table to decide on a textbook using the plurality with elimination method once again.
  - Is the monotonicity criterion satisfied? Explain your answer.
11. Charles Beauregard High School sponsors a senior class trip each year. This year, the students can choose between trips to Charleston, SC; Jacksonville, FL; New Orleans, LA; Chicago, IL; or Atlanta, GA. The students were asked to rank their choices in order to choose a destination.

Preference Table for Senior Class Trip				
Rankings				
<b>1st</b>	New Orleans, LA	Charleston, SC	Atlanta, GA	Chicago, IL
<b>2nd</b>	Chicago, IL	New Orleans, LA	New Orleans, LA	Charleston, SC
<b>3rd</b>	Atlanta, GA	Atlanta, GA	Chicago, IL	Atlanta, GA
<b>4th</b>	Charleston, SC	Jacksonville, FL	Charleston, SC	New Orleans, LA
<b>5th</b>	Jacksonville, FL	Chicago, IL	Jacksonville, FL	Jacksonville, FL
<b>Total Votes</b>	<b>375</b>	<b>348</b>	<b>289</b>	<b>115</b>

- Which city would be the senior trip destination using the plurality with elimination method?
- After consideration of travel time, the senior class sponsors decided to eliminate Chicago, IL, from the options. Which city is now the winning destination using plurality with elimination?
- Does the plurality with elimination method satisfy the irrelevant alternatives criterion? Explain your answer.

12. A nonprofit organization is looking to use social networking sites to increase interest. They poll donors to decide where to focus their resources. The donors are asked to rank the following sites by how often they use them.

Rankings				
<b>1st</b>	Facebook	Pinterest	Facebook	Twitter
<b>2nd</b>	Twitter	Facebook	Twitter	Facebook
<b>3rd</b>	Google+	Twitter	LinkedIn	LinkedIn
<b>4th</b>	LinkedIn	LinkedIn	Pinterest	Google+
<b>5th</b>	Pinterest	Google+	Google+	Pinterest
<b>Total Votes</b>	<b>23</b>	<b>40</b>	<b>44</b>	<b>35</b>

- Which site is given the higher ranking using the pairwise method of comparison?
  - If the nonprofit decides to eliminate Pinterest and Google+ from the list and adjust the votes accordingly, which site would then be the top place for the nonprofit to focus on using the pairwise method?
  - Does the pairwise method satisfy the irrelevant alternatives criterion for this preference table? Why or why not?
13. The men of the fraternity Chi Rho on campus are electing a new president. The candidates are M. Jones, H. Kennedy, and T. Parchment. The summary of the rankings of the candidates from the members is given in the chart.

Rankings				
<b>1st</b>	H. Kennedy	M. Jones	H. Kennedy	T. Parchment
<b>2nd</b>	M. Jones	T. Parchment	T. Parchment	H. Kennedy
<b>3rd</b>	T. Parchment	H. Kennedy	M. Jones	M. Jones
<b>Total Votes</b>	<b>8</b>	<b>14</b>	<b>10</b>	<b>11</b>

- Name the fraternity's next president using the Borda count method.
- Because of unexpected family issues, M. Jones had to withdraw from the university on short notice. Create a new preference table to show this change and then use the table to determine the next president using the Borda count method.
- Is the irrelevant alternatives criterion satisfied with this change? Explain your answer.

14. For the end of year banquet, the program committee needs to decide on the type of cuisine. They have four choices: Italian, French, Mexican, or Chinese. The following preference table summarizes the rankings of the members surveyed. Determine if the Condorcet criterion is satisfied if the committee uses the Borda count method to choose a cuisine.

**Preference Table for Banquet Cuisine**

		Rankings			
<b>1st</b>	French	Mexican	Italian	Italian	Mexican
<b>2nd</b>	Italian	Italian	Mexican	Chinese	French
<b>3rd</b>	Mexican	Chinese	French	Mexican	Chinese
<b>4th</b>	Chinese	French	Chinese	French	Italian
<b>Total Votes</b>	<b>4</b>	<b>21</b>	<b>14</b>	<b>11</b>	<b>9</b>

15. In preparation for their Oscar party, a sorority decides to have an election of their own. In the Best Actor category are George Clooney, Johnny Depp, Colin Firth, and Zac Efron. The rankings from the sorority members are shown in the following preference table. Determine if the majority criterion will be satisfied if the sorority uses the Borda count method to choose the winner for Best Actor.

**Preference Table for Best Actor**

		Rankings			
<b>1st</b>	Johnny Depp	Zac Efron	Johnny Depp	George Clooney	Colin Firth
<b>2nd</b>	Colin Firth	Colin Firth	George Clooney	Colin Firth	Zac Efron
<b>3rd</b>	Zac Efron	George Clooney	Zac Efron	Johnny Depp	Johnny Depp
<b>4th</b>	George Clooney	Johnny Depp	Colin Firth	Zac Efron	George Clooney
<b>Total Votes</b>	<b>26</b>	<b>16</b>	<b>16</b>	<b>15</b>	<b>9</b>

16. *Pretty People* magazine wants to name the number one activity for a first date amongst singles. They enlist the help of an online dating site that asks members to rank five activities in order of their preference as part of their sign-up process. The five activities include: movie, nice dinner, picnic, sporting event, and concert. The following preference table displays the results of the rankings. Determine if the Condorcet criterion is satisfied if the magazine uses the plurality method to name the top activity.

**Preference Table for First Date Activities**

		Rankings				
<b>1st</b>	Nice Dinner	Picnic	Picnic	Sporting Event	Sporting Event	Movie
<b>2nd</b>	Picnic	Sporting Event	Sporting Event	Concert	Nice Dinner	Nice Dinner
<b>3rd</b>	Concert	Concert	Nice Dinner	Picnic	Movie	Concert
<b>4th</b>	Movie	Nice Dinner	Concert	Nice Dinner	Concert	Picnic
<b>5th</b>	Sporting Event	Movie	Movie	Movie	Picnic	Sporting Event
<b>Total Votes</b>	<b>40</b>	<b>34</b>	<b>21</b>	<b>22</b>	<b>19</b>	<b>20</b>

17. United Way asks its volunteers to rank the nonprofit organizations it serves in order to give out the annual award for Local Volunteer of the Year. This year's organizations include the Breast Cancer Foundation, Community Garden, Big Brother/Big Sister, YMCA, and Manna Café. Complete the preference table so that Community Garden is the winner using the Borda count method, but the Condorcet criterion is violated.

Preference Table for Local Volunteer of the Year Award				
Rankings				
<b>1st</b>	MC	CG	BB/BS	
<b>2nd</b>	BB/BS	BCF	MC	
<b>3rd</b>	CG	BB/BS	CG	
<b>4th</b>	YMCA	YMCA	BCF	
<b>5th</b>	BCF	MC	YMCA	
<b>Total Votes</b>	<b>?</b>	<b>16</b>	<b>10</b>	

18. An online dating site asks new users to rank certain traits in order of importance when they are matched with another user. The site uses the top choice as the first criterion for matching people together. The following preference table summarizes the rankings for appearance, personality, income, profession, and height. Complete the preference table so that personality is the top trait if the site uses the Borda count method to count the votes and the majority criterion is not violated.

Preference Table for Important Traits					
Rankings					
<b>1st</b>	?	Personality	Income	Appearance	
<b>2nd</b>	?	Profession	Personality	Income	
<b>3rd</b>	Profession	Appearance	Appearance	Personality	
<b>4th</b>	Height	Height	Profession	Height	
<b>5th</b>	Income	Income	Height	Profession	
<b>Total Votes</b>	<b>45</b>	<b>56</b>	<b>33</b>	<b>48</b>	

19. College dining is considering opening a national fast food franchise on campus. Their choices have been narrowed down to Subway, Taco Bell, McDonald's, KFC, or Pizza Hut. Students were asked to rank these establishments in order of preference, and the results are shown in the preference table. If college dining uses the plurality method to choose the students' top choice of Subway, complete the preference table so that the irrelevant alternatives criterion is violated when KFC is removed from the race.

Preference Table for New Franchise on Campus					
Rankings					
<b>1st</b>	Subway	Taco Bell	KFC	Subway	
<b>2nd</b>	McDonald's	Subway	Taco Bell	Taco Bell	
<b>3rd</b>	Taco Bell	Pizza Hut	Subway	Pizza Hut	
<b>4th</b>	KFC	McDonald's	Pizza Hut	McDonald's	
<b>5th</b>	Pizza Hut	KFC	McDonald's	KFC	
<b>Total Votes</b>	<b>56</b>	<b>60</b>	<b>?</b>	<b>45</b>	

20. Sigma Air is exploring the possibility of establishing a new hub in one of the following cities: Cheyenne, WY; Little Rock, AR; Amarillo, TX; and Portland, OR. They surveyed their Gold and Platinum members to ask their preference for the new hub. Complete the preference table of the rankings so that using the plurality with elimination method Amarillo is the winner, and the Condorcet criterion is satisfied.

Preference Table for New Hub Location			
Rankings			
<b>1st</b>	Amarillo, TX	Portland, OR	Cheyenne, WY
<b>2nd</b>	Portland, OR	Little Rock, AR	Amarillo, TX
<b>3rd</b>	Cheyenne, WY	?	Little Rock, AR
<b>4th</b>	Little Rock, AR	?	Portland, OR
<b>Total Votes</b>	<b>70</b>	<b>34</b>	<b>37</b>

21. The following preference table summarizes the outcome of an election.

Preference Table for Candidates				
Rankings				
<b>1st</b>	Luke	Luke	Lauren	Blake
<b>2nd</b>	Hannah	Blake	Blake	Luke
<b>3rd</b>	Lauren	Lauren	Hannah	Lauren
<b>4th</b>	Blake	Hannah	Luke	Hannah
<b>Total Votes</b>	<b>31</b>	<b>9</b>	<b>23</b>	<b>41</b>

- Which candidate is the plurality winner?
  - Which candidate wins the election using a pairwise method of comparison?
  - Does this method satisfy the Condorcet criterion? Why or why not?
22. Every year, the Oviedo Little League gives out a Coach of the Year award. The board of directors selects three names to put on the ballot, and parents send in their votes. The results are shown in the following preference table.

Preference Table for Coach of the Year				
Rankings				
<b>1st</b>	Hall	McKee	Price	Hall
<b>2nd</b>	McKee	Price	McKee	Price
<b>3rd</b>	Price	Hall	Hall	McKee
<b>Total Votes</b>	<b>7</b>	<b>62</b>	<b>21</b>	<b>11</b>

- Which coach would win using the majority rule?
- Which coach would win using the Borda count method?
- Does the Borda count method satisfy the majority criterion

23. A high school math teacher is trying to pick a name for her puppy. She's narrowed it down to four choices and has decided to let the senior class vote. Determine if the majority criterion will be satisfied if the teacher uses the Borda count method to choose the winner.

Preference Table for Puppy Name					
	Rankings				
<b>1st</b>	Paladin	Knight	Knight	Paladin	Paladin
<b>2nd</b>	Ranger	Paladin	Whiskey	Ranger	Whiskey
<b>3rd</b>	Whiskey	Ranger	Paladin	Whiskey	Knight
<b>4th</b>	Knight	Whiskey	Ranger	Knight	Ranger
<b>Total Votes</b>	<b>26</b>	<b>73</b>	<b>68</b>	<b>51</b>	<b>25</b>

24. Suzie's family has a reunion every other year. On the last night of each reunion, family members can propose a location for the next reunion. Family members rank the top four proposals.

Preference Table for Reunion Location				
	Rankings			
<b>1st</b>	Charleston	San Diego	Dallas	New Orleans
<b>2nd</b>	Dallas	Charleston	San Diego	Dallas
<b>3rd</b>	San Diego	New Orleans	Charleston	Charleston
<b>4th</b>	New Orleans	Dallas	New Orleans	San Diego
<b>Total Votes</b>	<b>6</b>	<b>5</b>	<b>4</b>	<b>3</b>

- Use the plurality with elimination method to choose where the next reunion should be held.
- After some discussion among the cousins, the 3 family members whose rankings appear in the rightmost column decide to change their votes so that Charleston is their first pick, but the rest of their ranking keeps the same order. Create a new preference table to show this change and then use the table to decide on a location using the plurality of elimination method once again.
- Is the monotonicity criterion satisfied? Explain your answer.

## 13.2 PROJECT

### WHAT'S FAIR? DEPENDS ON WHO YOU ASK

In Section 13.2, we discussed five different conditions for determining the fairness of an election. Now it's time to explore how voting procedures and ideas about fairness impact elections in the real world. In this project, we'll consider the fairness of ranked-choice voting, which is equivalent to the plurality with elimination method that is used with preference ballots.

As a recap, here are the fairness criteria.

- The **Condorcet criterion** states that if a candidate wins the head-to-head comparison against every other candidate, then that candidate should also win the overall election in a fair voting system.

Notice that once the pre-professional group and its one representative is added in, the apportionment actually assigns the new branch two representatives, while the academic branch loses one. Because the addition of a new subgroup changed the apportionment of another subgroup, the new states paradox has occurred.

Hamilton's method of apportionment managed to be used for quite a long time in the United States House of Representatives before these paradoxes forced it to be replaced with some of the other methods we've looked at. However, although they avoided the paradoxes, these new methods created problems of their own. Occasionally, they violate what is known as the quota rule. The **quota rule** states that any fair apportionment method should assign every subgroup either its lower quota or its upper quota. Because the methods of apportionment introduced after Hamilton's all use a modified divisor, sometimes the modified quotas are different from the lower or upper quotas for that subpopulation.

#### THE QUOTA RULE

The **quota rule** states that any fair apportionment method should assign every subgroup either its lower quota or its upper quota.

Does a method exist that fairly apportions and does not violate any of the paradoxes or the quota rule? The short answer is no, although our examples in the text seem to suggest that it is possible because they adhere to the quota rule. However, in 1983, two mathematicians Michel Balinski and Peyton Young proved that there cannot be a perfect apportionment method. They proved that any apportionment method that does not violate the quota rule must produce paradoxes and any method that does not produce paradoxes must violate the quota rule. Although no perfect method for apportionment exists, we can make an informed decision about the most appropriate apportionment method, understanding the potential for flaws for paradoxes while striving to adhere to the quota rule.

#### **Skill Check Answers**

1. 25, 125    2. 6.4925; 3.8806; 6.6418    3. Math 4; History 8; Computer Science 6
4. Div. Pop 135 = 4; Div. Pop 98 = 3; Div. Pop 132 = 4
5. County 1 = 48; County 2 = 23; County 3 = 5; County 4 = 15; County 5 = 9

## 13.3 Exercises

### CONCEPT CHECK

1. A \_\_\_\_\_ represents the number of items that will be apportioned to each subgroup.
2. The Huntington-Hill method of apportionment uses the \_\_\_\_\_ to determine if the standard quota should be rounded up or down.
3. The \_\_\_\_\_ occurs when an increase in the number of available items causes a group to lose an item—even though populations remain the same.

4. The \_\_\_\_\_ states that subgroup A can lose an item to subgroup B even when the rate of growth of the population of subgroup A is greater than in subgroup B.
5. The \_\_\_\_\_ happens when the addition of a new subgroup, with a corresponding increase in the number of available items, can cause a change in the apportionment of items among the other subgroups.

 **PRACTICE**

Use the given table to solve each problem.

<b>Student Enrollment in the University of California System</b>		
<b>Campus</b>	<b>Enrollment</b>	<b>Full Time Equivalent (FTE)</b>
Berkeley	33,558	14,161
Davis	32,290	20,883
Irvine	28,000	12,558
Los Angeles	37,221	28,292
Merced	2700	799
Riverside	20,956	4689
San Diego	25,938	18,274
San Francisco	18,140	4174
Santa Barbara	21,016	6081
Santa Cruz	15,012	4597

6. The University of California system consists of 10 campuses and has a budget of \$2.6 billion in state funding. How much money in state funding would each campus receive if the state divided the money equally among the campuses (round to nearest dollar)?
7. If the state of California wanted to allocate the money equally based on total student enrollment, how much would be appropriated per student, rounded to the nearest cent?
8. Based on the result from Exercise 2, how much money would the campus of Los Angeles and Merced receive based on the number of students enrolled on each campus?
9. If the state apportions the funds based on FTE, how much money will the campuses of Davis and Santa Cruz receive (round to nearest dollar)?
10. As part of a “green” initiative, the state is wanting to apportion 500 new electric vehicles to their university system campuses. The state decides to apportion these vehicles based on the number of students at each university.
  - a. Find the SD.
  - b. Find the SQ for the San Francisco and Irvine campuses.

11. Supposed the state decides to apportion the 500 electric vehicles based on FTE.
  - a. Find the SD.
  - b. Find the SQ for the Riverside and Santa Barbara campuses.
12. Use the Hamilton method to apportion the 500 electric vehicles to all 10 campuses based on the number of students.
13. Use the Hamilton method to apportion the 500 electric vehicles to all ten campuses based on FTE. Compare your results with the apportionments from Exercise 7 and determine if the apportionments are different when the apportionment basis is different.

The given table shows the number of students enrolled in history, liberal arts math, and English during the fall and spring semesters. Use it to solve each problem.

Course Enrollment per Semester		
Subject	Fall	Spring
History	1902	1922
Liberal Arts Math	14,200	14,200
English	3898	3938

14. If there are 197 full time teaching positions available for apportionment among the three departments based on course enrollment, answer each of the following questions.
  - a. Find the number of teaching positions that should be apportioned to each department in the fall using Jefferson's method.
  - b. Find the number of teaching positions that should be apportioned to each department in the spring using Jefferson's method.
  - c. Does Jefferson's method create an example of the population paradox?
  - d. Find the number of teaching positions that should be apportioned to each department in the fall using Hamilton's method.
  - e. Find the number of teaching positions that should be apportioned to each department in the spring using Hamilton's method.
  - f. Does Hamilton's method create an example of the population paradox?
  - g. Find the number of teaching positions that should be apportioned to each department in the fall using the Huntington-Hill method.
  - h. Find the number of teaching positions that should be apportioned to each department in the spring using the Huntington-Hill method.
  - i. Does the Huntington-Hill method create an example of the population paradox?

 APPLICATIONS

15. An English teacher at a high school can teach six classes. There are 35 students enrolled in English I, 43 in English II, and 48 in English III.
- Find the SD and SQ to determine how many sections of each course should be offered?
  - Use the Jefferson method to determine the apportionment of students to the courses to determine the number of sections needed per course. determine the number of sections needed per course.
16. Repeat Exercise 15 b. using the Webster method.
17. Repeat Exercise 15 b. using the Hamilton method.
18. Repeat Exercise 15 b. using the Huntington-Hill method.
19. A county is divided into four districts with the populations of: Northern: 5500, Southern: 6350, Eastern: 3470, and Western: 1950. There are 16 seats on the county board to be apportioned.
- Use the Jefferson method to apportion the board seats.
  - Use the Huntington-Hill method to apportion the board seats.
  - Compare the apportionments for the Jefferson and Huntington-Hill methods and determine if there is a difference in how the seats are apportioned.
20. A biology department uses 25 graduate assistants in teaching its undergraduate courses. The enrollments for each of the courses that these students teach is as follows. How many graduate assistants should be assigned to each course using the Jefferson method?

Enrollment per Course	
Course	Enrollment
Survey of Biology	450
Zoology	200
Cell Biology	175
Plant Biology	280

21. Use the Hamilton method to round each of the following numbers to a whole number while preserving the total.

$$12.65 + 3.48 + 2.57 + 4.39 + 1.91 = 25$$

22. Use Hamilton's method to round each of the following numbers to a whole number while preserving the total.

$$32.61 + 58.37 + 55.02 + 23.11 + 54.89 = 224$$

23. Suppose there are 76 faculty members in the sciences, 86 in the humanities, and 16 in the professional and trade schools. An 11-person faculty committee is to be formed.
- Use Hamilton's method to determine the allocation of committee members based on department size.
  - Use Jefferson's method to determine the allocation of committee members based on department size.
  - Use the Huntington-Hill method to determine the allocation of committee members based on department size.
  - Use Webster's method to determine the allocation of committee members based on department size.
24. Suppose Learn-A-Lot University has enrollments on its three campuses as follows. There are 40 police officers to be distributed among these campuses based on enrollment. Use Hamilton's method to apportion the police officers.

Enrollment per Campus			
Campus	1	2	3
Enrollment	10,170	9150	680

25. If the number of police officers to be apportioned increases by 1 to 41 (see Exercise 24) determine the apportionment of officers using Hamilton's Method and show that the Alabama paradox occurs when the number of officers increases by 1.
26. Suppose a country has six states with populations as given in the table. There are 250 seats in the House of Representatives for this country. Use Webster's method to apportion the representatives.

Population by State	
State	Population
A	1646
B	6936
C	154
D	2091
E	685
F	988
<b>Total</b>	<b>12,500</b>

27. Suppose a college homecoming planning committee has 17 members. The makeup of the committee is to be based on the size of the classes: Freshman = 422, Sophomore = 356, Junior = 321, and Senior = 288.
- Find the number of members from each class to be apportioned to the committee using Webster's method.
  - Find the number of members from each class to be apportioned to the committee using Jefferson's method.
  - Find the number of members from each class to be apportioned to the committee using the Huntington-Hill method.

**Skill Check Answers**

1. Players = 3; Quota = 6; Total number of votes = 9    2. Yes, it is a winning coalition.  
 3. Yes, player 4 is critical    4. Player 1 is the pivotal player    5.  $P_1 = P_2 = P_3 = P_4 = 25\%$

## 13.4 Exercises

### ✓ CONCEPT CHECK

1. A group of players joining together to vote the same way is called a \_\_\_\_\_.
2. A \_\_\_\_\_ is a player who causes a winning coalition to become a losing coalition if they were to leave.
3. A player with the power to form a winning coalition by themselves is called a \_\_\_\_\_.
4. The total number of sequential coalitions is found from the following formula: \_\_\_\_\_.

### 💡 PRACTICE

5. Five partners start a business, with each owning the following number of shares:  $P_1$  owns 9 shares,  $P_2$  owns 6 shares,  $P_3$  owns 5 shares,  $P_4$  owns 3 shares, and  $P_5$  owns 2 shares. If one share is equal to one vote and they use a simple majority quota, represent this weighted voting system.
6. Using the information in Exercise 5, if the quota is a two-thirds majority, represent the weighted voting system.
7. Consider the weighted voting system  $[25: 10, 7, 4, 4, 2, 2, 1, 1, 1]$ .
  - a. What is the quota for this voting system?
  - b. What is the weight of  $P_5$ ?
  - c. If only the last six voters vote for a motion, does the motion pass?
  - d. If  $P_1$  and  $P_2$  vote against a motion, does the motion pass?
8. Consider the weighted voting system  $[q: 10, 7, 4, 4, 2, 2, 1, 1, 1]$ .
  - a. What is the smallest quota that requires a majority for this voting system?
  - b. What is the largest quota for this voting system?
9. In the weighted voting system  $[q: 20, 19, 15, 8, 4, 2]$ , if a two-thirds majority of votes is needed, what is  $q$ ?
10. Which players in the voting system  $[20: 7, 7, 3, 3, 2]$  have veto power?
11. In the weighted voting system  $[q: 18, 15, 12, 9, 6, 3]$ , what is the largest value of  $q$  so that no voter has veto power?

12. In the weighted voting system  $[q: 10, 7, 4, 4, 2, 2]$ , if every voter has veto power, what is  $q$ ?
13. Consider the weighted voting system  $[42: 22, 16, 10, 6, 4]$ . Does this voting system contain a dictator? Does this system contain a dummy player?
14. Consider the weighted voting system  $[20: 12, 10, 3]$ . Does this voting system contain a dictator? Does this system contain a dummy player?
15. Consider the weighted voting system  $[42: 20, 16, 10, 6, 4]$ .
- How many voters are in the system?
  - What is the quota for the system?
  - Is the coalition  $\{P_2, P_3, P_4, P_5\}$  a winning coalition?
  - What are all of the winning coalitions?
  - Are there any critical players?
  - Do any of the players have veto power?
16. Consider the weighted voting system  $[42: 20, 16, 10, 6, 4]$ . Determine the Banzhaf Power Index for each player.

Consider the weighted voting system  $[30: 12, 10, 9, 5, 4, 4]$ . Determine the pivotal player in each of the sequential coalitions listed.

17.  $\langle P_1, P_3, P_2, P_6 \rangle$
18.  $\langle P_4, P_2, P_3, P_6, P_5, P_1 \rangle$
19. Consider the weighted voting system  $[7: 4, 2, 2, 2, 2]$ . Find the Banzhaf Power Index for each voter. Are any of the voters dictators? Do any of the voters have veto power?
20. Find the Banzhaf Power Index for each player in the voting system  $[10: 7, 5, 3, 2]$ .
21. Consider the weighted voting system,  $[100: 80, 60, 30, 20]$ . Calculate the Shapley-Shubik Power Index for each player in this system. Are any of the voters dictators? Do any of the voters have veto power?

 APPLICATIONS

22. The United Nations Security Council consists of fifteen members of the United Nations; five permanent member countries and ten nonpermanent member countries. In order for a vote to pass, nine members, including all five of the permanent members, must be in agreement. An equivalent weighted voting system is [39: 7, 7, 7, 7, 7, 1, 1, 1, 1, 1, 1, 1, 1, 1]. According to our previous calculations, this means there are  $15!$  or about 1.3 trillion permutations for the members.<sup>1</sup>
- Without computing all possible coalitions, determine when a nonpermanent member would be a pivotal voter.
  - What is the Shapley-Shubik Power Index for each nonpermanent member?
  - What is the Shapley-Shubik Power Index for the combined nonpermanent members?
  - What is the Shapley-Shubik Power Index for each permanent member?
  - What is the Shapley-Shubik Power Index for the combined permanent members?
23. There are 435 members of the United States House of Representatives.
- If a simple majority is needed to pass a bill, what constitutes a winning coalition?
  - If a two-thirds majority is needed to ratify an amendment, what constitutes a winning coalition?
24. In the weighted voting system [43: 25, 20, 19, 17], determine each of the following.
- List all permutations in which  $P_1$  is a pivotal player.
  - List all permutations in which  $P_2$  is a pivotal player.
  - Calculate the Shapley-Shubik Power Index for each player.
  - Calculate the Banzhaf Power Index for each player.
  - Is there a player with veto power?
25. If the quota in Exercise 23 is increased to 50, how would the Shapley-Shubik Power Index change?

<sup>1</sup> United Nations, <http://www.un.org>

26. A company has five shareholders and a total of 500 shares. The quota for passing a measure is the number of votes where shareholders own 251 or more shares. The number of shares owned by each shareholder is as follows:  $S_1 = 200$ ,  $S_2 = 123$ ,  $S_3 = 120$ ,  $S_4 = 40$ , and  $S_5 = 17$ . Suppose there is an investor  $S_6$  that wants to buy shares and currently owns no shares:
- What are the winning and losing coalitions? Compute the number of votes needed to make a losing coalition a winning coalition.
  - How many shares can  $S_1$  sell to  $S_2$  without causing any of the winning coalitions listed in part **a.** to lose or any of the losing coalitions in part **a.** to win?
  - How many shares can  $S_1$  sell to  $S_5$  without causing any of the winning coalitions listed in part **a.** to lose or any of the losing coalitions in part **a.** to win?
  - How many shares can  $S_1$  sell to  $S_6$  without causing any of the winning coalitions listed in part **a.** to lose or any of the losing coalitions in part **a.** to win?

## 13.4 PROJECT

### POWER DYNAMICS AT PLAY

In Section 13.4, you learned about weighted voting systems and the power that each player in the system has. In this project, you'll investigate power dynamics. Power dynamics are where weighted voting systems get interesting. Players may have opposing viewpoints that motivate them to desire different outcomes. Each player wants to win and wants to know the likelihood of winning.

Consider a small company with a small number of shareholders who disagree about the direction the company should take. Each member is likely to be acutely aware of how much their vote counts and with whom they need to align to be part of a winning coalition. Let's look at a few power dynamics at play.

- Consider a scenario where player 1 is a dictator and is interested in selling some shares to another player, but wants to remain a dictator after the sale. Is this possible in the voting system  $[20: 25, 5, 3, 1]$ ? Explain why this is or isn't possible. If it is possible, how many shares can player 1 sell?
- Consider a scenario where player 1 and player 4 rarely vote in the same manner, while player 2 and player 4 often vote the same. In the voting system  $[14: 12, 7, 3, 2]$ , why would player 4 be glad to see player 1 sell two shares to player 2? (**Hint:** Consider the possible winning coalitions in each voting system.)
- Using the same scenario as part 2, use the Banzhaf Power Index to describe in words how player 4's power changes if player 1 sells two shares to player 2.

**Skill Check Answers**

1. Any of the following:  $c, b, a, e$ ;  $c, b, a, d$ ;  $c, b, a, b$ ;  $c, b, c, b$ ;  $c, d, a, e$ ;  $c, d, a, b$ ;  $c, d, a, d$ ;  $c, d, c, d$  2. Adjacent vertices:  $x$  and  $y$ ;  $u$  and  $w$ ;  $v$  and  $x$ ; Incident edges:  $e_1$  and  $e_2$ ;  $e_3$  and  $e_4$ ;  $e_3$  and  $e_5$ ;  $e_4$  and  $e_5$   
 3. Answers will vary. For example,

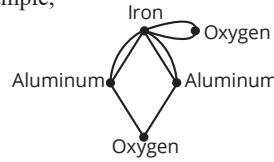

4.  $B = \{b, e, j\}$   
 5. Answers will vary.  
 For example,  $a, b, d, h, g, e$ ;  $g, e, a, b, f, h$ ;  $b, f, h, d, e, a$ ;  $d, e, g, h, f, b$ .

# 14.1 Exercises

✓ CONCEPT CHECK

- The \_\_\_\_\_ of a vertex is the number of edges that are incident to that vertex.
- A/an \_\_\_\_\_ consists of a set of vertices and a set of edges that connect pairs of vertices.
- A/an \_\_\_\_\_ associates a pair of vertices in a graph.
- The end of an edge in a graph is called a/an \_\_\_\_\_.
- A/an \_\_\_\_\_ is an edge whose ends are the same vertex.
- Two edges are said to be \_\_\_\_\_ if they share a vertex.
- The \_\_\_\_\_ of a graph is the minimum number of colors needed in a vertex coloring of a graph.
- Two vertices are said to be \_\_\_\_\_ if they share an edge.
- A sequence of vertices such that each vertex is adjacent to the next in the list, the last vertex is adjacent to the first, and there are no repeated edges or vertices, except for the starting vertex, is called a/an \_\_\_\_\_.

💡 PRACTICE

List the vertices and edges of each graph.

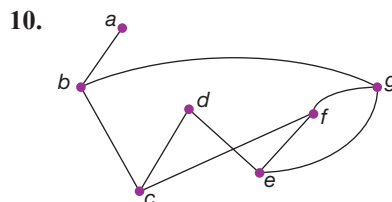

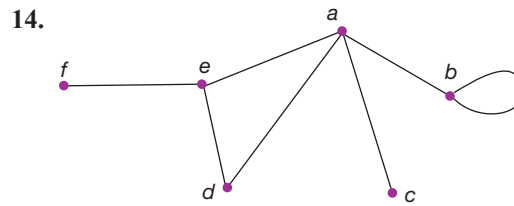
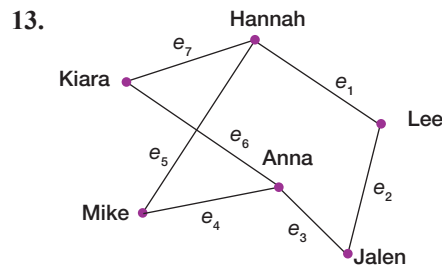
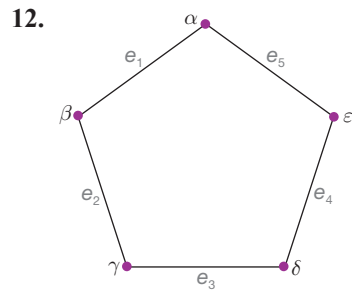
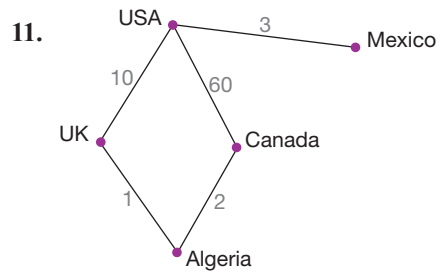

15. Use the graph to answer the following.

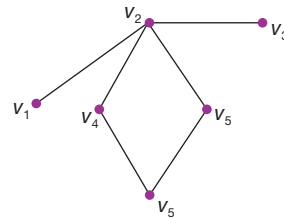

- Identify a walk of length two that starts at vertex  $v_1$  and ends at vertex  $v_3$ .
- Is the walk in part a. closed?
- Identify a closed walk.

16. Use the graph to answer the following.

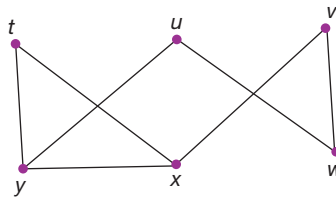

- a. Identify a walk of length 3 that starts at vertex  $u$  and ends at vertex  $v$ .
- b. Identify a walk of length 5 that starts at vertex  $t$  and ends at vertex  $t$ .
- c. Are the walks in parts a. and b. closed?

17. An **Euler trail** in a graph  $G$  is a walk that contains every edge in  $G$  precisely once. Each of the following graphs contains an Euler trail, identify it.

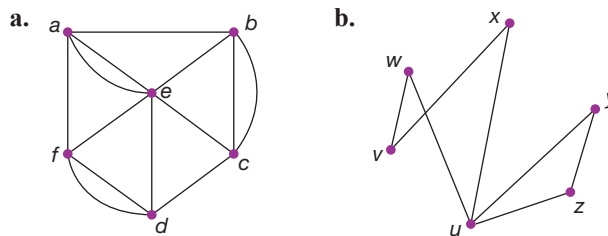

18. Identify two paths in the following graph. What is the length of each path?

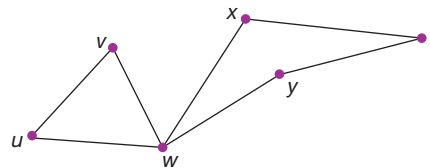

19. The length of a path is the number of edges in the path. Identify a path of the specified length in the graph.

- a. Path of length 2
- b. Path of length 3
- c. Path of length 6

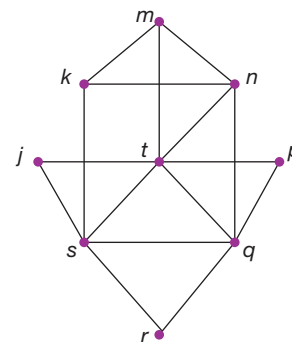

20. Which of the given graphs is connected?

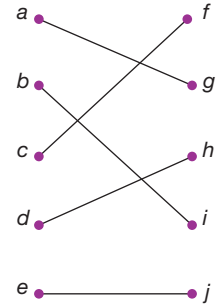
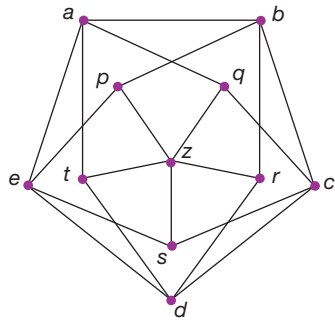

21. Which of the given graphs is connected?

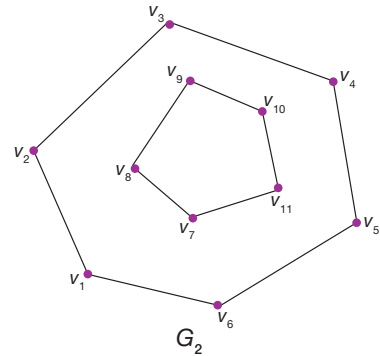
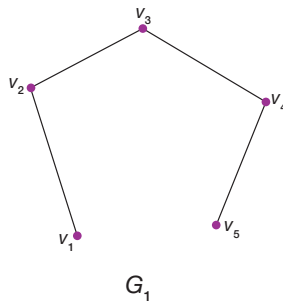

22. Are the two given graphs the same graph? Explain.

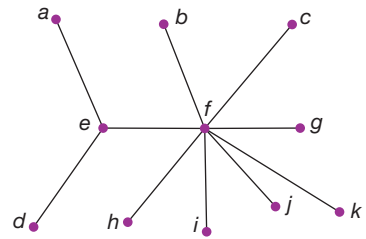
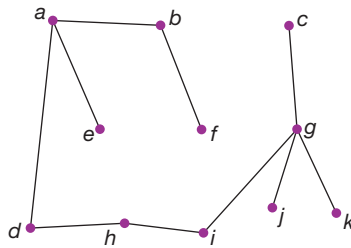

23. Are the two given graphs the same? Explain.

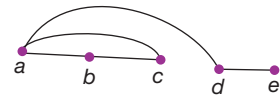
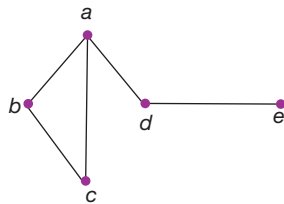

24. Draw a graph that has five vertices  $r, s, t, u, v$ , and the edges  $rt, ru, rv, st, su$ , and  $sv$ .

25. Draw a graph with vertices  $u, v, w, x, y, z$ , and edges  $ux, uv, uy, vx, vy, vw, wy, wz, wx$ , with no crossings.

26. Draw a graph that has 7 vertices  $a, b, c, d, e, f, g$ , and edges  $ab, ac, ae, bc, cd, de, ef, fg$ , and  $gg$ .



32. Identify the following features in the given graph. In some cases, more than one answer is correct.

- a. Two adjacent vertices
- b. Two incident edges
- c. Two vertices that are not adjacent
- d. A vertex of degree 2

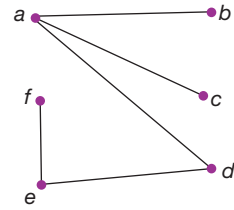

33. A **Hamilton cycle** in a graph  $G$  is a cycle that contains every vertex in  $G$ . Decide if the following graphs contain Hamilton cycles.

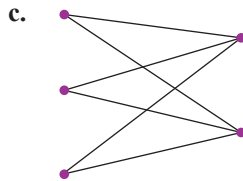
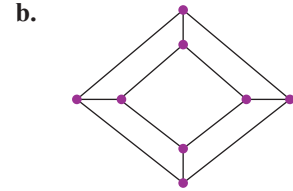
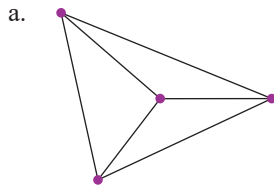

APPLICATIONS

34. The graph shows a blueprint of rooms in a museum. Find a way to place guards in the rooms so that every room either has a guard or shares a doorway with a room that has a guard and the minimum number of guards is used.

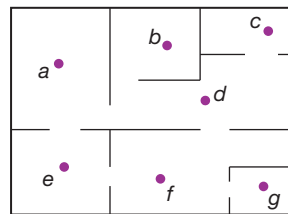

35. The graph shows a blueprint of rooms in a house. Find a way to place security cameras so that every room either has a camera or shares a doorway with a room that has a camera, and the minimum number of cameras is used.

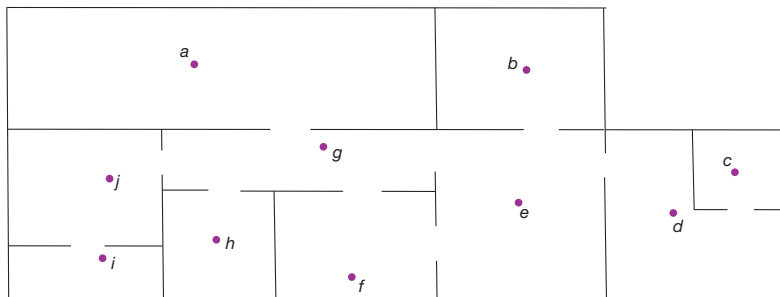

36. Use a vertex coloring to assign colors to the counties of Vermont so that adjacent counties have different colors. What is the minimum number of colors required? Find a vertex coloring using the minimum number of colors.

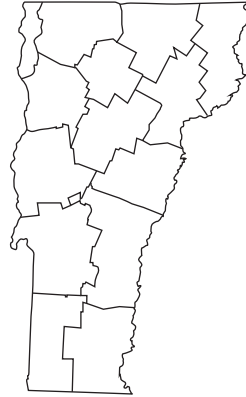

37. Use a vertex coloring to assign colors to the counties of Connecticut so that adjacent counties have different colors. What is the minimum number of colors required? Find a vertex coloring using the minimum number of colors.

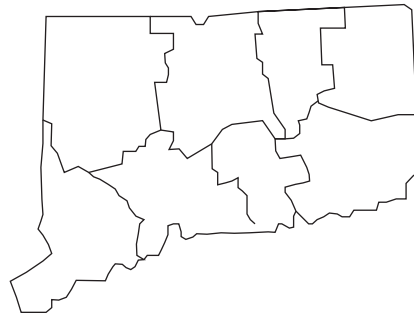

 **WRITING & THINKING**

38. Draw two different connected graphs, each with four vertices and four edges.

# 14.2 Exercises

## ✓ CONCEPT CHECK

1. A tree is a \_\_\_\_\_ graph with no cycles.
2. If graph  $T$  is a tree on  $v$  vertices, then graph  $T$  has  $v - 1$  \_\_\_\_\_.
3. A \_\_\_\_\_ is a subgraph of a connected graph, which is itself connected and contains all the vertices of the original graph but has no cycles.
4. To find a spanning tree, start by identifying any \_\_\_\_\_ in the graph and delete enough edges to break the \_\_\_\_\_ while keeping the graph connected.
5. A vertex of degree \_\_\_\_\_ in a tree is called a leaf.

## 💡 PRACTICE

Determine if each graph is a tree.

6.

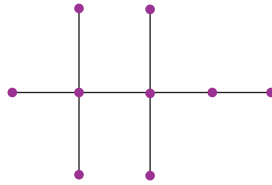

7.

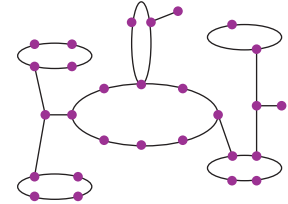

8.

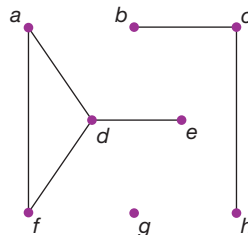

9.

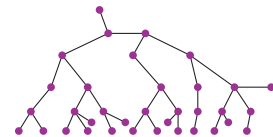

Determine the number of edges needed to form a tree in each graph.

10.

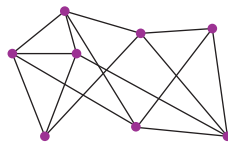

11.

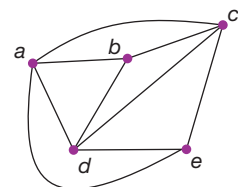

12.

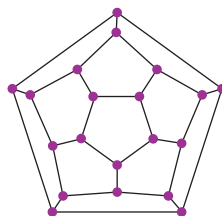

13.

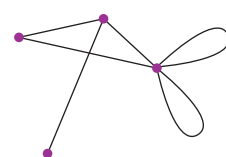

Find a spanning tree in each graph.

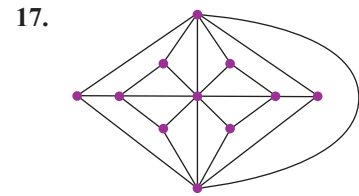
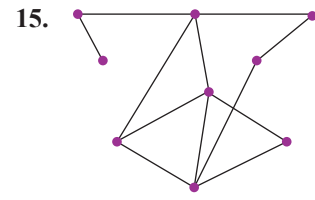
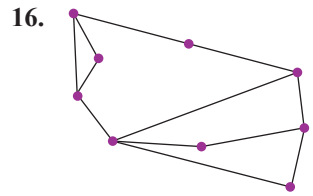
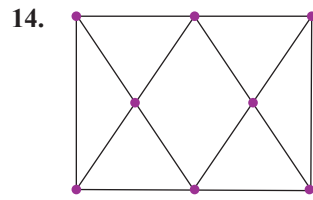

Find the number of leaves in each tree.

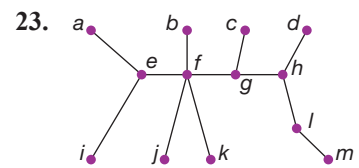
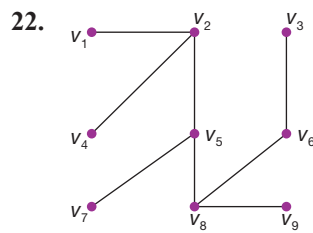
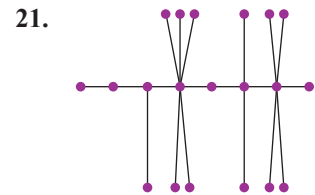
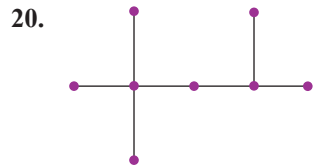
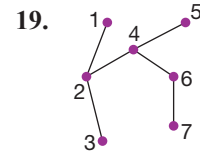
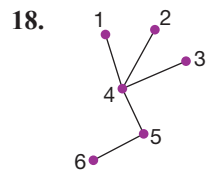

24. Let  $T$  be a tree with internal vertices of degree 4, 5, 6, 2, and 3. How many leaves does  $T$  have?

### APPLICATIONS

25. The sidewalks at a university are laid out according to the following graph. Each corresponding edge is labeled with the length of that section of sidewalk. If all of the sidewalks are covered with snow, which sections of sidewalks should be cleared to connect all sections of the university while clearing as little snow as possible?

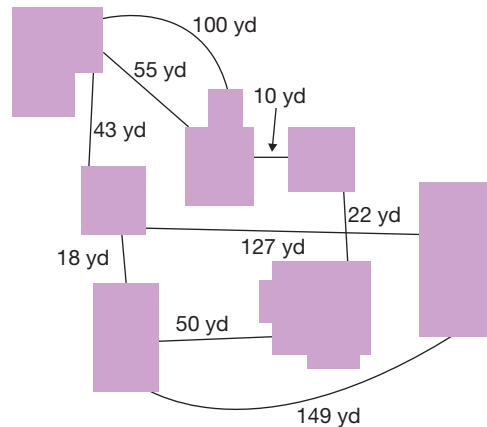

26. A traveling salesman has to visit a number of destinations by a route that is as short as possible. Let  $G$  be a graph in which the vertices are the destinations, the edges represent roads that join the destinations, and the weights represent the lengths of the roads.
- If the minimum spanning tree has a weight of 100 miles, show that the salesman must drive at least 100 miles to visit all of the destinations.
  - Show that he needs to drive no more than 200 miles to complete his route.
27. Eurojet Hovercrafts has five hubs connecting European destinations on both sides of the English Channel. If the routes form a tree, with the five hubs having routes to 4, 5, 7, 3, and 6 ports respectively, how many cities are served by Eurojet Hovercrafts?

### WRITING & THINKING

28. What is the chromatic number of a tree? (**Hint:** Recall from Section 14.1 that the chromatic number of a graph is the number of colors used in a minimum vertex coloring.)

## 14.2 PROJECT

### ALGEBRA TREES

In this project, you will explore the use of trees to represent algebraic expressions and other mathematical formulas. Writing expressions in this way can be useful when trying to create a computer program that performs complicated calculations. For example, if we want to represent the expression  $x + y$  we could use the following tree.

**Skill Check Answers**

1. Yes    2.  $N(B) = \{f, g, i\}$   
 3. Answers will vary. For example,

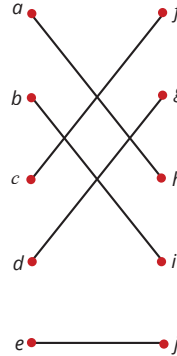

## 14.3 Exercises

✓ **CONCEPT CHECK**

1. A \_\_\_\_\_ is one in which the vertices can be broken into two distinct groups where each vertex in the first group is joined to a vertex in the second group.
2. By Hall's Marriage Theorem, we know that a \_\_\_\_\_ graph has a matching.
3. A \_\_\_\_\_ is a subset of edges in a graph so that each vertex is incident with only one edge.
4. In a \_\_\_\_\_, every vertex has the same degree.
5. Given a set of vertices  $A$ , the \_\_\_\_\_ of  $A$  is the set of all vertices adjacent to a vertex in  $A$ .

💡 **PRACTICE**

Determine if each graph is bipartite. Justify your answer.

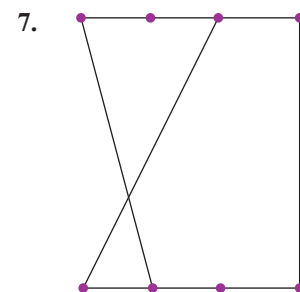
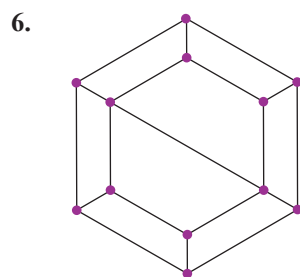

Use Graph  $Q$  to identify the neighborhood of each set.

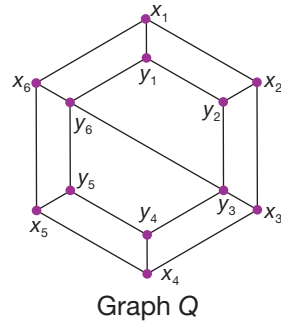

8.  $A = \{x_1, y_1\}$
9.  $B = \{\text{the set of odd numbered } x\text{'s}\}$
10.  $C = \{y \text{ vertices}\}$
11.  $D = \{\text{all vertices in } Q\}$

Determine if each graph has a matching. Justify your answer.

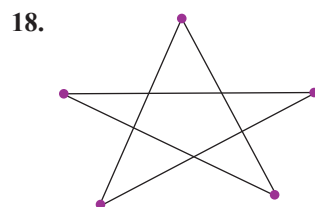
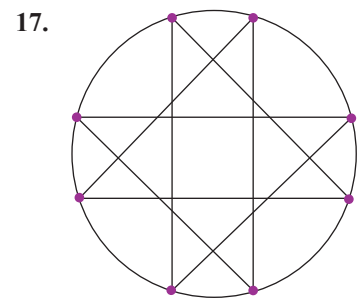
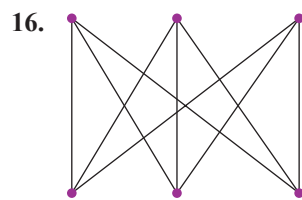
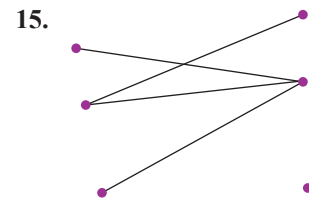
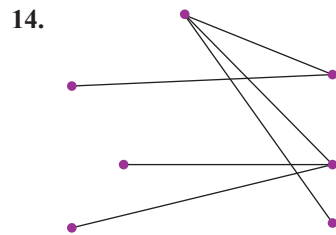
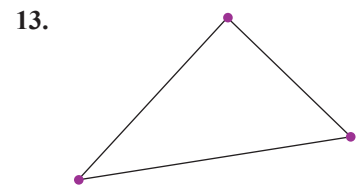
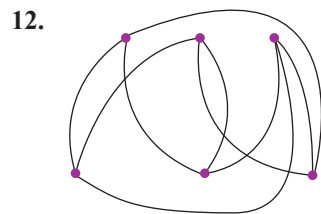

19. Use Hall's Marriage Theorem to determine if there is a matching in the following graph.

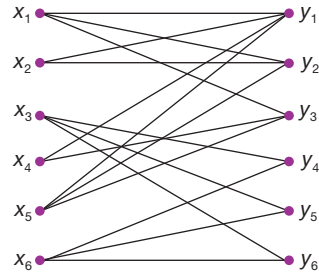

Determine if each graph is regular bipartite.

20.

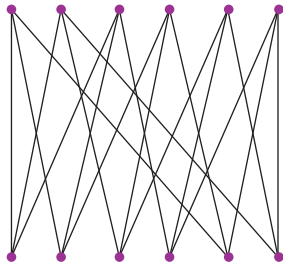

21.

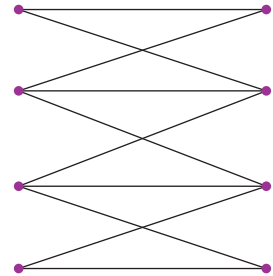

22.

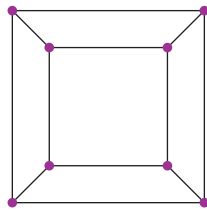

23.

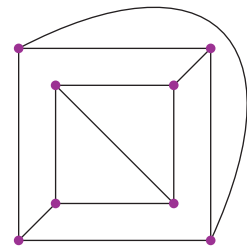

24. Is Grötzsch's graph bipartite?

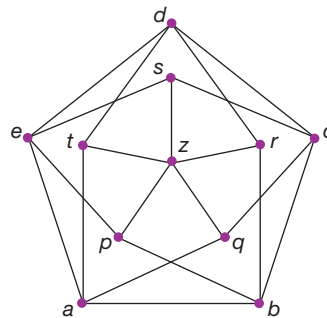

Find a matching in each regular bipartite graph.

25.

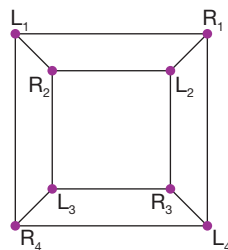

26.

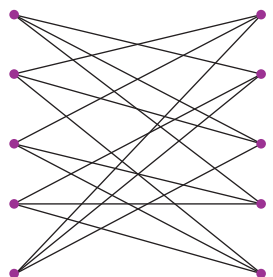

Form a bipartite graph from the information in each table. Find a matching for each scenario, if possible.

27.

Teacher	Courses
Mr. Hall	Political Science, American History
Ms. Cutlidge	English I, English II, English III, Advanced Writing, Computer Science
Mrs. Roseview	English I, English II, English III, Advanced Writing
Mr. Burden	Algebra II, Precalculus, Calculus, PE
Mr. Smith	American History, US History, Economics, Political Science
Mrs. Jones	Political Science, US History, PE, Computer Science
Ms. Rodriguez	Algebra I, Algebra II, Geometry, Calculus

28.

Volunteers	Positions Willing to Serve In
Kerri	greeter, usher, refreshments
Luke	parking attendant, usher
Ron	sound board, video, lights
Jose	lights, parking attendant, greeter
Cho	nursery, sound board, video
Mia	refreshments, nursery, greeter
Margaret	parking attendant, refreshments, lights
Lenton	video, nursery, greeter

29. Use Schriver's Algorithm to find a matching of the British Museum example given in the text. We know from the text that it is a regular bipartite graph, and hence does have a matching.

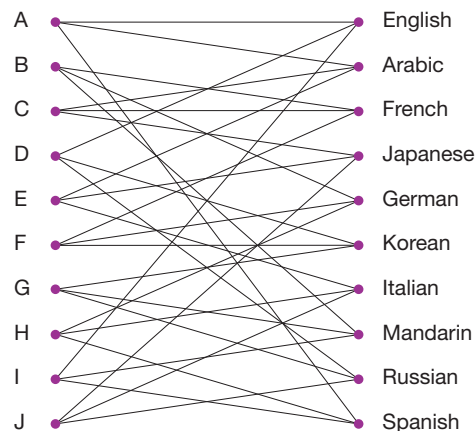

### ✎ WRITING & THINKING

30. Let graph  $G$  be a bipartite graph with the same number of vertices on each side. Suppose that for every set of vertices  $B$  on the right-hand side, the number of vertices in  $\mathcal{N}(B)$  on the left-hand side is at least as large as the number of vertices in  $B$ . Explain why graph  $G$  has a matching from the left-hand side to the right-hand side.
31. An edge coloring of a graph  $G$  is an assignment of colors to the edges, so that incident edges have different colors. Explain why edges of the same color form a matching.

# 14.4 Exercises

✓ **CONCEPT CHECK**

1. Graphs that can be drawn on a plane without \_\_\_\_\_ are called planar graphs.
2. In a planar graph, a \_\_\_\_\_ is a region inside a cycle of edges or the infinite exterior region on the outside of the graph.
3. Euler's formula states that if  $G$  is a connected planar graph with  $v$  vertices,  $e$  edges, and  $f$  faces, then \_\_\_\_\_.
4. A planar graph  $G$  with  $v$  vertices has at most \_\_\_\_\_ edges.
5. A \_\_\_\_\_ graph is defined to be a graph in which each vertex is connected to all other vertices.

💡 **PRACTICE**

Draw each planar graph without any crossing edges.

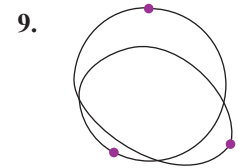
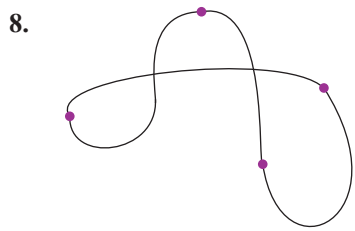
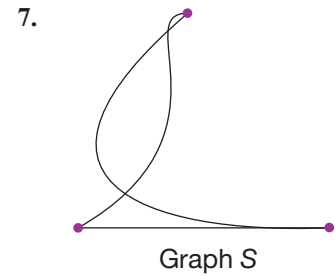
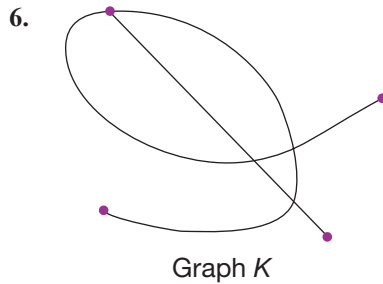

Determine the number of faces in each planar graph.

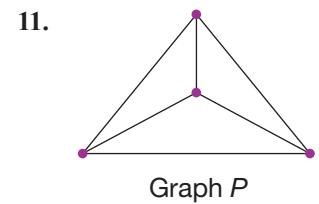
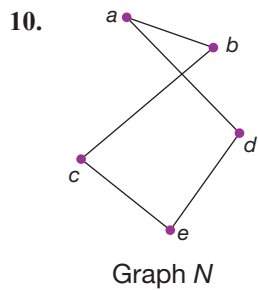

12.

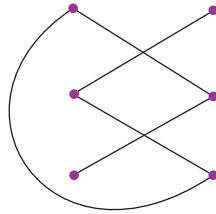

Graph *E*

Verify Euler's formula for each graph.

13.

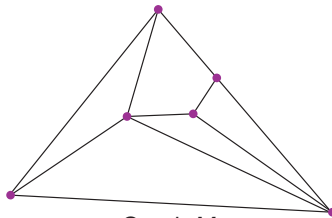

Graph *M*

14.

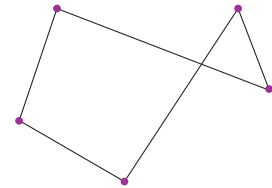

Graph *Z*

15.

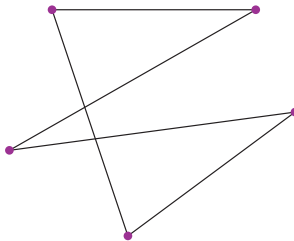

Graph *F*

16.

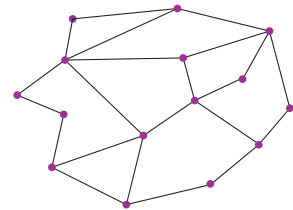

Graph *C*

Use Euler's formula and the corollary of Euler's formula.

17. If a graph  $G$  has 9 vertices, what is the greatest number of edges that graph  $G$  can have and be a planar graph?
18. If a graph  $G$  has 16 vertices, what is the greatest number of edges that graph  $G$  can have and be a planar graph?
19. If  $G$  is a connected planar graph with 8 vertices and 10 edges, then how many faces does  $G$  have?
20. If  $G$  is a connected planar graph with 10 edges and 6 faces, then how many vertices does  $G$  have?

Determine if each graph is planar.

21.

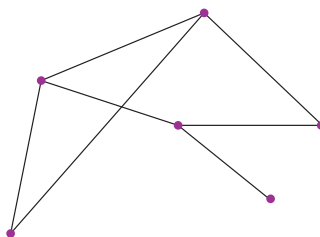

Graph *T*

22.

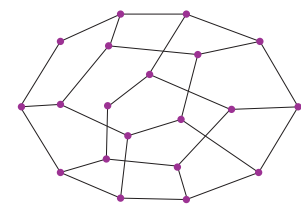

Graph *B*

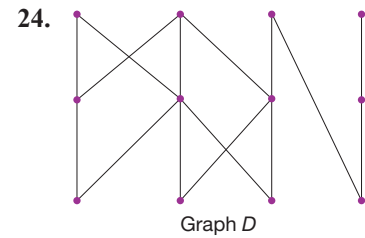
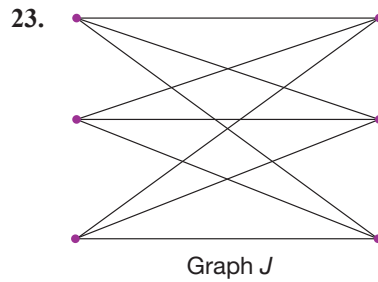

 APPLICATIONS

25. A new housing development wants to connect three houses to their three utilities (gas, water and electric) without their cables/pipes crossing. Can it be done?

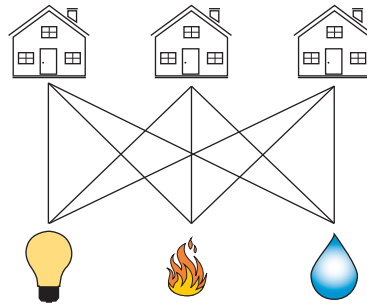

 WRITING & THINKING

26. Show that a planar graph must have a vertex of degree at most 5.
27. Find the chromatic number of  $K_3$ ,  $K_5$ , and  $K_n$ .
28. Find the chromatic number of  $K_{5,5}$  and  $K_{k,k}$ .
29. Show that any planar graph can also be drawn on a sphere.
30. What happens if you draw the graph of a cube on a sphere and then flatten the faces so that they are the same size?

## 14.4 PROJECT

### PLANAR POLYHEDRONS

In this section, you learned about planar graphs and how their numbers of  $v$  vertices,  $e$  edges, and  $f$  faces are related by Euler's formula:  $v + f - e = 2$ . You may have also learned about vertices, edges, and faces in geometry as part of the study of convex polyhedrons. A convex polyhedron is a solid made up of flat polygonal faces joined at their edges and vertices with the additional property that any line segment joining any two points on the surface of the polyhedron stays on or inside the polyhedron.