

b.  $-6x = 30$

$$-6x \left( -\frac{1}{6} \right) = 30 \left( -\frac{1}{6} \right)$$

$$x = -5$$

Using multiplicative cancellation, we multiply both sides by  $-\frac{1}{6}$ , then simplify.

Alternatively, dividing both sides by  $-6$  yields the same result. Thus, the equation  $-6x = 30$  is equivalent to equation  $x = -5$ . We can see how cancellation properties can help us *solve* equations for variables.

- c. Multiplying both sides of the equation  $x^2 - x = 2$  by 0 leads to the equation  $0 = 0$  a true statement. However, these two equations are not equivalent!

While replacing  $x$  in the first equation by  $-1$  or  $2$  leads to a true statement, any other value for  $x$  leads to a false statement. By contrast, the equation  $0 = 0$  is true for all values of  $x$ , as there is no  $x$  in the equation to replace with a number. This example illustrates why we must multiply both sides of an equation by a nonzero quantity to apply multiplicative cancellation.

- d. The equation  $(x - y)(x + y) = 0$  means that  $x - y = 0$  or  $x + y = 0$ , by the Zero-Factor Property. Remember that the only way for a product of two (or more) factors to be 0 is for *at least* one of the factors to be 0 itself. For instance, in this example it might be that *both*  $x - y = 0$  and  $x + y = 0$ . If  $x = 0$  and  $y = 0$ , this is indeed the case.

## 1.1 EXERCISES

### PRACTICE

Which elements of the following sets are **a.** natural numbers, **b.** whole numbers, **c.** integers, **d.** rational numbers, **e.** irrational numbers, **f.** real numbers? See Example 1.

1.  $\left\{ 19, -4.3, -\sqrt{3}, \frac{0}{15}, 2^5, -33 \right\}$

2.  $\left\{ 5\sqrt{7}, 4\pi, \sqrt{16}, 3.\bar{3}, -1, \frac{22}{7}, |-8| \right\}$

Plot the real numbers in the following sets on a number line. Choose the unit length appropriately for each set.

3.  $\{-4.5, -1, 2.5\}$     4.  $\{-24, 2, 15\}$     5.  $\{5.1, 5.2, 5.8\}$     6.  $\left\{ 0, \frac{1}{2}, \frac{5}{6} \right\}$

Select all of the symbols from the set  $\{<, \leq, >, \geq\}$  that can be placed in the blank to make each statement true.

7.  $12$        $14$

8.  $-102$        $9$

9.  $3$        $3$

10.  $-50$        $-45$

11.  $-3.4$        $-3.5$

12.  $-\frac{1}{4}$        $-\frac{1}{3}$

Write each statement as an inequality, using the appropriate inequality symbol.

13. “ $2a + b$  is strictly greater than  $c$ ”      14. “2 is less than or equal to  $x$ ”  
 15. “ $2c$  is no more than  $3d$ ”      16. “ $6 + x$  is greater than or equal to  $4x$ ”

Describe each of the following sets using set-builder notation. There may be more than one correct way to do this. See Example 4.

17.  $\{5, 6, 7, \dots, 105\}$       18.  $\{2, 3, 5, 7, 11, 13, 17, \dots\}$   
 19.  $\{1, 2, 4, 8, 16, 32, \dots\}$       20.  $\{-6, -3, 0, 3, 6, 9\}$   
 21.  $\left\{\dots, \frac{1}{3}, \frac{1}{5}, \frac{1}{7}, \frac{1}{9}, \dots\right\}$       22.  $\{0, 1, 2, 3, 4, 5, \dots\}$

Write each set as an interval using interval notation. See Example 5.

23.  $\{x \mid -3 \leq x < 19\}$       24.  $\{x \mid x < 4\}$       25.  $x < 15$   
 26.  $-9 \leq x \leq 6$       27. The positive real numbers  
 28. The nonnegative real numbers

Graph the following intervals.

29.  $[5, 14)$       30.  $[-9, -1]$       31.  $(0, 2)$   
 32.  $(-3, 18]$       33.  $(-\infty, 7]$       34.  $(25, \infty)$

Simplify the following set expressions. See Example 6.

35.  $[-7, 7) \cup (2, 5)$       36.  $(-5, 2] \cup (2, 4)$   
 37.  $(-5, 2] \cap (2, 4]$       38.  $[3, 5] \cap [2, 4]$   
 39.  $(-\infty, 4] \cup (0, \infty)$       40.  $(-\infty, \infty) \cap [-\pi, 21)$

Simplify the following set expressions. See Example 7.

41.  $\mathbb{Q} \cap \mathbb{Z}$       42.  $\mathbb{N} \cup \mathbb{R}$   
 43.  $\mathbb{N} \cup \mathbb{Z} \cap \mathbb{Q}$       44.  $(-4.8, -3.5) \cap \mathbb{Z}$

Evaluate the absolute value expressions. See Examples 8 and 9.

45.  $-|-11|$       46.  $|3 - 7|$       47.  $|\sqrt{3} - \sqrt{5}|$   
 48.  $|\sqrt{2}|$       49.  $\frac{|-x|}{|x|} (x \neq 0)$       50.  $-|4 - 9|$   
 51.  $-|-4 - |-11||$       52.  $-|\sqrt{|-9|} - |-9||$

Find the distance on the real number line between each pair of numbers given. See Example 8.

53.  $a = 8, b = 3$

54.  $a = 5, b = 5$

55.  $a = 4, b = -2$

56.  $a = -12, b = -1$

Identify the components of the algebraic expressions, as indicated. See Example 10.

57. Identify the terms in the expression  $3x^2y^3 - 2\sqrt{x+y} + 7z$ .

58. Identify the factors in the term  $-2\sqrt{x+y}$ .

59. Identify the coefficients in the expression  $x^2 + 8.5x - 14y^3$ .

60. Identify the factors in the term  $8.5x$ .

61. Identify the terms in the expression  $\frac{-5x}{2yz} - 8x^5y^3 + 6.9z$ .

62. Identify the coefficients in the expression  $\frac{-5x}{2yz} - 8x^5y^3 + 6.9z$ .

Evaluate the following algebraic expressions for the given values of the variables. See Example 11.

63.  $3x^3 + 5x - 2$  for  $x = -3$

64.  $\sqrt{2x} + \frac{3x}{4}$  for  $x = 8$

65.  $-3\pi y + 8x + y^3$  for  $x = 2$  and  $y = -2$

66.  $y\sqrt{x^3 - 2} + \sqrt{x - 2y} - 3y$  for  $x = 3$  and  $y = -\frac{1}{2}$

67.  $|x - 9y| - (8z - 8)$  for  $x = -3, y = 1,$  and  $z = 5$

68.  $\frac{x^2y^3}{8z} - \frac{|2xy|}{8z}$  for  $x = 2, y = -1,$  and  $z = 3$

Identify the property that justifies each of the following statements. If one of the cancellation properties is being used to transform an equation, identify the quantity that is being added to both sides or the quantity by which both sides are being multiplied. See Examples 12 and 14.

69.  $(x - y)(z^2) = (z^2)(x - y)$

70.  $3 - 7 = -7 + 3$

71.  $4(y - 3) = 4y - 12$

72.  $-3(4x^6z) = (-3)(4)(x^6z) = -12x^6z$

73.  $4 + (-3 + x) = (4 - 3) + x = 1 + x$

74.  $(x + y)\left(\frac{1}{x + y}\right) = 1$

75.  $25x^3 = 10y \Leftrightarrow 5x^3 = 2y$

76.  $-14y = 7 \Leftrightarrow y = -\frac{1}{2}$

77.  $14 - x = 2x \Leftrightarrow 14 = 3x$

78.  $(a + b)(x) = 0 \Rightarrow a + b = 0$  or  $x = 0$

79.  $\frac{x}{6} + \frac{y}{3} - 2 = 0 \Leftrightarrow x + 2y - 12 = 0$       80.  $x^2z = 0 \Rightarrow x^2 = 0$  or  $z = 0$

81.  $5 + 3x - y = 2x - y \Leftrightarrow 5 + x = 0$

82.  $(x - 3)(x + 2) = 0 \Rightarrow x - 3 = 0$  or  $x + 2 = 0$

 **APPLICATIONS**

83. Jess, Stan, Nina, and Michele are in a marathon. Twenty-five minutes after beginning, Jess has run 3.4 miles, Stan has run 4 miles, Nina has run 2.25 miles, and Michele has walked 1.6 miles. Using 0 as the beginning point, plot each competitor's location on a real number line using an appropriate interval.
84. Freddie, Sarah, Elizabeth, JR, and Aubrey are trying to line up by height for a photo shoot. JR is the tallest and Elizabeth is the shortest. Freddie is taller than Sarah, and Sarah is taller than Aubrey. Express their lineup using appropriate inequality symbols.
85. Sue boards an eastbound train in Center Station at the same time Joy boards a westbound train in Center Station. After riding the Straight Line for 20 minutes, Sue's train has traveled 13 miles east, while Joy's train (also on the Straight Line) has traveled 7 miles west. Find the distance between the two trains at this time. (Assume the Straight Line is true to its name and that the tracks lie literally along a straight line.)
86. The admission prices at the local zoo are as follows.

**Admission Prices**

|                     |      |
|---------------------|------|
| Children under 2    | free |
| Children under 12   | \$3  |
| Adults              | \$7  |
| Seniors (65 and up) | \$5  |

Express the age range for each of these prices in set-builder notation and interval notation.

87. A particular fudge recipe calls for at least 3 but no more than 4 cups of sugar and at least  $\frac{1}{2}$  but no more than  $\frac{2}{3}$  of a cup of walnuts. Express the amount of sugar and nuts needed in both set-builder and interval notation.
88. At the beginning of the month, your checking account contains \$128. For your birthday, your mother deposits \$50 and your grandmother deposits \$25. After you write three checks for \$17, \$23, and \$62, you make a deposit of \$41. At the end of the month, your bank removes half of the balance to put in your savings account and then charges you a \$5 fee for doing so. How much do you have remaining in your checking account?
89. A particular liquid boils at 268 °F. Given the formula  $C = \frac{5}{9}(F - 32)$  for converting temperatures from Celsius ( $C$ ) to Fahrenheit ( $F$ ), find the boiling point of this liquid in the Celsius scale. Round your answer to two decimal places.

90. Stephen received \$75 as a gift from his aunt. With this money, he decided to start saving to buy the newest gaming console, which costs \$398 after tax. After working two weeks at his part-time job, he got one check for \$123 and a second check for \$98. How much more does Stephen need to save to buy his gaming console?
91. Body mass index, abbreviated BMI, is one way doctors determine an adult's weight status. A BMI below 18.5 is considered underweight, the range 18.5–24.9 is normal, the range 25.0–29.9 is overweight, and a BMI above 30.0 indicates obesity. The formula used to determine BMI is  $BMI = 703 \left( \frac{\text{weight in pounds}}{(\text{height in inches})^2} \right)$ . Derek weighs 180 pounds and is 73 inches tall. Use this formula to determine Derek's BMI and weight status. Round your answer to one decimal place.
92. The Du Bois Method provides a formula used to estimate your body's surface area in meters squared:  $BSA = 0.007184h^{0.725}w^{0.425}$  where  $h$  is height in centimeters and  $w$  is weight in kilograms. Assume Juan is 193 cm tall and weighs 88 kg. Use the Du Bois Method to estimate his body's surface area in square meters. Round your answer to two decimal places.
93. Samantha drops a tennis ball from the top of the mathematics building. If it takes the ball 3.42 seconds to hit the ground, use the formula  $\text{distance} = \frac{1}{2}(\text{acceleration})(\text{time})^2$  to find the height of the building, which is equivalent to the distance the ball falls. Use the value of  $32 \text{ ft/s}^2$  for the acceleration of a falling object. Round your answer to the nearest foot.



### WRITING & THINKING

94. Choose a number. Multiply it by 3 and then add 4. Now multiply by 2 and subtract 8. Finally divide by 6. What do you notice about your final answer? Explain why you got this as a result.
95. After taking a poll in her town, Sally began grouping the citizens into various sets. One set contained all the citizens with brown hair and another set contained all the citizens with blue eyes. What do you know about the citizens who would be listed in the union of these two sets? What do you know about the citizens who would be listed in the intersection of these two sets?
96. Can a natural number be irrational? Explain.
97. Are all whole numbers also integers? Are all integers also whole numbers? Explain your answers.
98. In your own words, define absolute value.
99. Write a short paragraph explaining the similarities and differences between  $>$  and  $\geq$ .
100. In your own words, explain the difference between a union and an intersection of two sets.

 TECHNOLOGY

Select all of the symbols from the set  $\{<, \leq, >, \geq\}$  that can be placed in the blank to make each statement true. Use a graphing utility to check your answers.

101.  $-2.9$  \_\_\_  $-3.1$

102.  $2.1$  \_\_\_  $-5.5$

103.  $100$  \_\_\_  $-4$

104.  $0.001$  \_\_\_  $-99.8$

105.  $\frac{1}{3}$  \_\_\_  $\frac{1}{4}$

106.  $-\frac{1}{5}$  \_\_\_  $-\frac{3}{4}$

Use a graphing utility to evaluate the following algebraic expressions.

107.  $\sqrt{x^4y - z} + \frac{x - y^3}{z^2}$  for  $x = -3$ ,  $y = 2$ , and  $z = -2$

108.  $\frac{(x - pq^2)^3}{2q^3}$  for  $x = -5$ ,  $p = 2$ , and  $q = -3$

109.  $\frac{|x^2 - y^3| - 4x}{3y^5}$  for  $x = 2$  and  $y = 3$

110.  $\sqrt{p^3q - q^3} - |p + q^2|$  for  $p = -5$  and  $q = 2$

Simplifying the expressions in the next example requires a bit more work and/or caution.

### Example 14: Simplifying Radical Expressions

- a. Simplify the expression  $\sqrt[4]{x^2}$ .
- b. Write  $\sqrt[3]{2} \cdot \sqrt{3}$  as a single radical.

#### Solution

$$\begin{aligned} \text{a. } \sqrt[4]{x^2} &= (x^2)^{\frac{1}{4}} \\ &= |x|^{\frac{1}{2}} \\ &= \sqrt{|x|} \end{aligned}$$

We might be tempted to write  $\sqrt[4]{x^2}$  as simply  $\sqrt{x}$ , but note that  $\sqrt[4]{x^2}$  is defined for *all* real numbers  $x$ , while  $\sqrt{x}$  is defined only for nonnegative real numbers. We can rectify this disparity by first making sure the radicand is nonnegative.

$$\begin{aligned} \text{b. } \sqrt[3]{2} \cdot \sqrt{3} &= 2^{\frac{1}{3}} \cdot 3^{\frac{1}{2}} \\ &= 2^{\frac{2}{6}} \cdot 3^{\frac{3}{6}} \\ &= (2^2)^{\frac{1}{6}} (3^3)^{\frac{1}{6}} \\ &= 4^{\frac{1}{6}} \cdot 27^{\frac{1}{6}} \\ &= 108^{\frac{1}{6}} \\ &= \sqrt[6]{108} \end{aligned}$$

We can make use of the property  $a^n b^n = (ab)^n$  if we can first make the exponents equal. We do so by finding the least common denominator of  $\frac{1}{3}$  and  $\frac{1}{2}$ , writing both fractions with this common denominator, and then making use of the property  $a^m = (a^n)^{\frac{m}{n}}$ .

## 1.2 EXERCISES

### PRACTICE

Simplify each of the following expressions, writing your answer with only positive exponents. See Examples 1 and 2.

- |                      |                      |                    |
|----------------------|----------------------|--------------------|
| 1. $(-2)^4$          | 2. $-2^4$            | 3. $3^2 \cdot 3^2$ |
| 4. $\frac{7^4}{7^5}$ | 5. $\frac{x^5}{x^2}$ | 6. $n^2 \cdot n^5$ |

Use the properties of exponents to simplify each of the following expressions, writing your answer with only positive exponents. See Examples 1, 2, and 3.

- |                          |                  |                          |
|--------------------------|------------------|--------------------------|
| 7. $\frac{3t^{-2}}{t^3}$ | 8. $9^0 x^3 y^0$ | 9. $\frac{2n^3}{n^{-5}}$ |
|--------------------------|------------------|--------------------------|

10.  $\frac{x^7 y^{-3} z^{12}}{x^{-1} z^9}$

11.  $\frac{s^5 y^{-5} z^{-11}}{s^8 y^{-7}}$

12.  $\frac{(3yz^{-2})^0}{3y^2 z}$

13.  $\left[9m^2 - (2n^2)^3\right]^{-1}$

14.  $\frac{(-3a)^{-2} (bc^{-2})^{-3}}{a^5 c^4}$

15.  $\left[(5m^4 n^{-2})^{-1}\right]^{-2}$

16.  $\left[(4a^2 b^{-5})^{-1}\right]^{-3}$

17.  $\left[(3^{-1} x^{-1} y)(x^2 y)^{-1}\right]^{-3}$

18.  $\left[\frac{100^0 (x^{-1} y^3)^{-1}}{x^2 y}\right]^{-3}$

19.  $\left(5z^6 - (3x^3)^4\right)^{-1}$

20.  $\left[\frac{y^6 (xy^2)^{-3}}{3x^{-3} z}\right]^{-2}$

Convert each number from scientific notation to standard notation, or vice versa, as indicated. See Example 4.

21.  $-912,000,000$ ; convert to scientific

22.  $0.00000021$ ; convert to scientific

23.  $3.2 \times 10^7$ ; convert to standard

24.  $1.934 \times 10^{-4}$ ; convert to standard

25. There are approximately 31,536,000 seconds in a calendar year. Express the number of seconds in scientific notation.

26. Together, the 46 human chromosomes are estimated to contain some  $3.0 \times 10^9$  base pairs of DNA. Express the number of pairs of DNA in standard notation.

27. A white blood cell is approximately  $3.937 \times 10^{-4}$  inches in diameter. Express this diameter in standard notation.

28. The probability of winning the lottery with one dollar is approximately 0.0000002605. Express this probability in scientific notation.

Evaluate each expression using the properties of exponents. Use a calculator only to check your final answer. See Example 5.

29.  $\frac{(2 \times 10^3)(7 \times 10^{-2})}{(5 \times 10^4)}$

30.  $\frac{(8 \times 10^{-3})(3 \times 10^{-2})}{(2 \times 10^5)}$

31.  $(2 \times 10^{-13})(5.5 \times 10^{10})(-1 \times 10^3)$

32.  $(6 \times 10^{21})(5 \times 10^{-19})(5 \times 10^4)$

33.  $\frac{4 \times 10^{-6}}{(5 \times 10^4)(8 \times 10^{-3})}$

34.  $\frac{(4.6 \times 10^{12})(9 \times 10^3)}{(1.5 \times 10^8)(2.3 \times 10^{-5})}$

Apply the definition of integer exponents to demonstrate the following properties.

35.  $a^n \cdot a^m = a^{n+m}$

36.  $(a^n)^m = a^{nm}$

37.  $(ab)^n = a^n b^n$

Evaluate the following radical expressions. See Example 7.

$$\begin{array}{lll}
 38. -\sqrt{9} & 39. \sqrt[3]{-27} & 40. \sqrt{-25} \\
 41. \sqrt[3]{-\frac{27}{125}} & 42. \sqrt{\frac{25}{121}} & 43. -\sqrt[3]{-8} \\
 44. \sqrt[4]{\sqrt{16} - \sqrt[3]{-27} + \sqrt{81}} & 45. \sqrt{\frac{\sqrt[3]{-64}}{-\sqrt{144} - \sqrt{169}}} & 
 \end{array}$$

Simplify the following radical expressions. See Example 9.

$$\begin{array}{lll}
 46. \sqrt[3]{-8x^6y^9} & 47. \sqrt{2x^6y} & 48. \sqrt[7]{x^{14}y^{49}z^{21}} \\
 49. \sqrt{\frac{x^2}{4x^4y^6}} & 50. \sqrt[3]{\frac{a^3b^{12}}{27c^6}} & 51. \sqrt[4]{\frac{x^{12}y^8}{16}} \\
 52. \sqrt[5]{\frac{y^{30}z^{25}}{32x^{35}}} & 53. \sqrt[5]{32x^7y^{10}} & 
 \end{array}$$

Simplify the following radicals by rationalizing the denominators. See Example 10.

$$\begin{array}{lll}
 54. \sqrt[3]{\frac{4x^2}{3y^4}} & 55. \frac{-\sqrt{3a^3}}{\sqrt{6a}} & 56. \frac{10}{\sqrt{7} - \sqrt{2}} \\
 57. \frac{3}{\sqrt{6} - \sqrt{3}} & 58. \frac{\sqrt{x}}{\sqrt{x} - \sqrt{2}} & 59. \frac{\sqrt{x} + \sqrt{y}}{\sqrt{x} - \sqrt{y}}
 \end{array}$$

Rationalize the numerators of the following expressions. See Example 11.

$$\begin{array}{lll}
 60. \frac{3 + \sqrt{y}}{6} & 61. \frac{\sqrt{13} + \sqrt{t}}{13 - t} & 62. \frac{2\sqrt{x} + \sqrt{y}}{\sqrt{x} - \sqrt{y}}
 \end{array}$$

Combine the radical expressions, if possible. See Example 12.

$$\begin{array}{ll}
 63. \sqrt[3]{-16x^4} + 5x\sqrt[3]{2x} & 64. \sqrt{27xy^2} - 4\sqrt{3xy^2} \\
 65. \sqrt{7x} - \sqrt[3]{7x} & 66. -x^2\sqrt[3]{54x} + 3\sqrt[3]{2x^7} \\
 67. \sqrt[5]{32x^{13}} + 3x\sqrt[5]{x^8} & 68. \sqrt[3]{-16z^4} + 6z\sqrt[3]{2z}
 \end{array}$$

Simplify the following expressions, writing your answer using the same notation as the original expression. See Example 13.

$$\begin{array}{lll}
 69. \sqrt[3]{\sqrt[4]{x^{36}}} & 70. 32^{-\frac{3}{5}} & 71. (3x^2 - 4)^{\frac{1}{3}}(3x^2 - 4)^{\frac{5}{3}} \\
 72. 81^{\frac{3}{4}} & 73. (-8)^{\frac{2}{3}} & 74. 625^{-\frac{3}{4}} \\
 75. \sqrt[3]{\sqrt[5]{y^{25}}} & 76. \frac{(a-b)^{-\frac{2}{3}}}{(a-b)^{-2}} & 
 \end{array}$$

Convert the following expressions from radical notation to exponential notation, or vice versa. Simplify each expression in the process, if possible.

77.  $256^{\frac{3}{4}}$

78.  $\sqrt[12]{x^3}$

79.  $\sqrt[6]{\frac{2}{72}}$

80.  $(36n^4)^{\frac{5}{6}}$

Simplify the following expressions. See Example 14.

81.  $\sqrt{5} \cdot \sqrt[4]{5}$

82.  $\sqrt[3]{x^7} \cdot \sqrt[9]{x^6}$

83.  $\sqrt[5]{y^{16}} \cdot \sqrt[25]{y^{20}}$

84.  $\sqrt[4]{7} \cdot \sqrt[16]{7}$

Apply the definition of rational exponents to demonstrate the following properties.

85.  $\sqrt[n]{ab} = \sqrt[n]{a} \cdot \sqrt[n]{b}$

86.  $\sqrt[n]{\frac{a}{b}} = \frac{\sqrt[n]{a}}{\sqrt[n]{b}}$

87.  $\sqrt[m]{\sqrt[n]{a}} = \sqrt[mn]{a}$

### 🧠 APPLICATIONS

88. The prism shown below is a right triangular cylinder, where the base is a right triangle. Find the volume of the prism in terms of  $b$ ,  $h$ , and  $l$ .

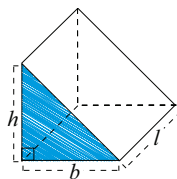

89. Determine the volume of the right circular cylinder shown, in terms of  $r$  and  $h$ .

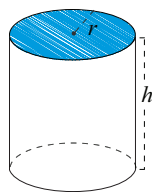

90. Matt wants to let people in the future know what life is like today, so he goes shopping for a time capsule. Capacity, along with price and quality, is an important consideration for him. One time capsule he looks at is a right circular cylinder with a hemisphere on each end. Find the volume of the time capsule, given that the length  $l$  of the cylinder is 16 inches and the radius  $r$  is 3 inches.

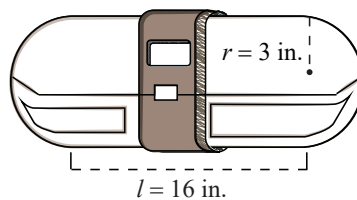

91. Bill and Dee are buying a new house. The house is a right cylinder based on a trapezoid atop a rectangular prism. The bases of the trapezoid are  $B = 10$  m and  $b = 8$  m, and the length of the house is  $l = 15$  m. The height of the house up to the bottom of the roof is  $H = 3$  m, and the height of the roof is  $h = 1$  m. Find the volume of the house.

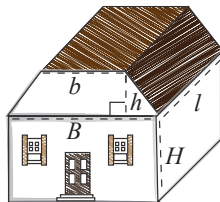

92. Determine the expression for the volume of water contained in an above-ground circular swimming pool that has a diameter of 18 feet, assuming the water has a uniform depth of  $d$  feet.
93. The floor of a rectangular bedroom measures  $N$  feet wide and  $M$  feet long. The height of the walls is 7 feet. Find an expression for the number of square feet of wallpaper needed to cover all the walls. (Ignore the presence of doors and windows.)
94. The interior surface of the birdbath in Example 6c needs to be painted with a waterproof (and nontoxic) coating. Determine the expression for the interior surface area.
95. The prism shown below is a right triangular cylinder, where the base is a right triangle. Find the surface area of the prism in terms of  $b$ ,  $h$ , and  $l$ .

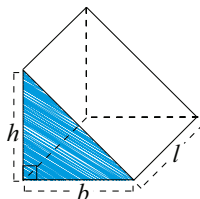

96. A jeweler decides to construct a pendant for a necklace by simply attaching equilateral triangles to each edge of a regular hexagon. The edge length of one of the points of the resulting star is  $d = 0.8$  cm. Find the formula for the area of the star in terms of  $d$  and then evaluate for  $d = 0.8$  cm (rounding to three decimal places). Use the fact that the area of an equilateral triangle of side length  $d$  is  $A = \frac{d^2\sqrt{3}}{4}$ .

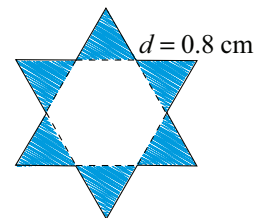

97. Ilyana has made a home for her pet guinea pig (Ralph) in the shape of a right triangular cylinder. Before she can put the new home in Ralph's cage, she must paint it with a nontoxic outer coat. If the front of the home has a base of 17.5 cm and a height of 15 cm and the length of the home is 25 cm, what is the surface area of Ralph's home, rounded to the nearest square centimeter? The small bottle of nontoxic coating will cover up to  $1500 \text{ cm}^2$ . Will the small bottle contain enough nontoxic coating to cover Ralph's home?

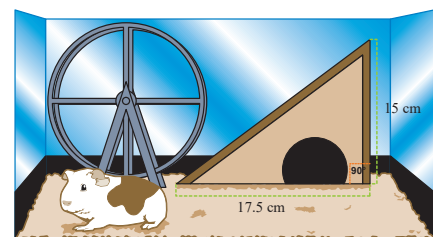

98. Einstein's Theory of Special Relativity tells us that  $E = mc^2$ , where  $E$  is energy (in joules, J),  $m$  is mass (in kilograms, kg), and  $c$  is the speed of light (in meters per second, m/s). This equation may also be written as  $\sqrt{\frac{E}{m}} = c$ . Assume you know  $E = 418,400$  J and  $m = 4.655 \times 10^{-12}$  kg. Use this information to estimate the speed of light.

**WRITING & THINKING**

99. Give a few examples of instances in which it would be more useful to use scientific notation rather than standard.
100. In February of 2006, the US national debt was approximately 8.2 trillion dollars. How is saying 8.2 trillion similar to scientific notation? How is it different?
101. In your own words, explain why  $a^0 = 1$ .
102. Explain, in your own words, why the square root of a negative number is not a real number.
103. Explain, in your own words, why exponents and roots are evaluated at the same time in the order of operations.

**Example 12:** Factoring Expressions with Noninteger Rational Exponents

Factor each of the following algebraic expressions.

a.  $3x^{-\frac{2}{3}} - 6x^{\frac{1}{3}} + 3x^{\frac{4}{3}}$

b.  $(x-1)^{\frac{1}{2}} - (x-1)^{-\frac{1}{2}}$

**Solution**

$$\begin{aligned}
 \text{a. } 3x^{-\frac{2}{3}} - 6x^{\frac{1}{3}} + 3x^{\frac{4}{3}} &= 3x^{-\frac{2}{3}}(1 - 2x + x^2) \\
 &= 3x^{-\frac{2}{3}}(x^2 - 2x + 1) \\
 &= 3x^{-\frac{2}{3}}(x-1)(x-1) \\
 &= 3x^{-\frac{2}{3}}(x-1)^2
 \end{aligned}$$

Under the guidelines above, we factor out  $3x^{-\frac{2}{3}}$ . Note that we use the properties of exponents to obtain the terms in the second factor.

We notice that the second factor is a second-degree trinomial, which is itself factorable. In fact, it is an example of a perfect square trinomial.

$$\begin{aligned}
 \text{b. } (x-1)^{\frac{1}{2}} - (x-1)^{-\frac{1}{2}} &= (x-1)^{-\frac{1}{2}}[(x-1) - 1] \\
 &= (x-1)^{-\frac{1}{2}}(x-2)
 \end{aligned}$$

In this example we factor out  $(x-1)^{-\frac{1}{2}}$  again using the properties of exponents to obtain the terms in the second factor.

**1.3 EXERCISES****PRACTICE**

Classify each of the following expressions as either a polynomial or not a polynomial. For those that are polynomials, identify the degree of the polynomial and the number of terms (use the words monomial, binomial, and trinomial if applicable). See Example 1.

1.  $3x^{\frac{3}{2}} - 2x$

2.  $17x^2y^5 + 2z^3 - 4$

3.  $5x^{10} + 3x^3 - 2y^3z^8 + 9$

4.  $\pi x^3$

5. 8

6. 0

7.  $7^3xy^2 + 4y^4$

8.  $abc^2d^3$

9.  $4x^2 + 7xy + 5y^2$

10.  $3n^4m^{-3} + n^2m$

11.  $\frac{y^2z}{4} + 2yz^4$

12.  $6x^4y + 3x^2y^2 + xy^5$

Write each of the following polynomials in descending order, and identify **a.** the degree of the polynomial, and **b.** the leading coefficient.

13.  $-4x^{10} - x^{13} + 9 + 7x^{11}$

14.  $9x^8 - 9x^{10}$

15.  $4s^3 - 10s^5 + 2s^6$

16.  $4 - 2x^5 + x^2$       17.  $9y^6 - 2 + y - 3y^5$       18.  $4n + 6n^2 - 3$   
 19.  $8z^2 + \pi z^5 - 2z + 1$       20.  $-6y^5 - 3y^7 + 12y^6$

Add or subtract the polynomials, as indicated. See Example 2.

21.  $(-4x^3y + 2xz - 3y) - (2xz + 3y + x^2z)$       22.  $(4x^3 - 9x^2 + 1) + (-2x^3 - 8)$   
 23.  $(x^2y - xy - 6y) + (xy^2 + xy + 6x)$       24.  $(5x^2 - 6x + 2) - (4 - 6x - 3x^2)$   
 25.  $(a^2b + 2ab + ab^2) - (ab^2 + 5ab + a^2b)$       26.  $(x^4 + 2x^3 - x + 5) - (x^3 - x - x^4)$   
 27.  $(xy - 4y + xy^2) + (3y - x^2y - xy)$       28.  $(-8x^4 + 13 - 9x^2) - (8 - 2x^4)$

Multiply the polynomials, as indicated. See Examples 3 and 4.

29.  $(3a^2b + 2a - 3b)(ab^2 + 7ab)$       30.  $(x^2 - 2y)(x^2 + y)$   
 31.  $(3a + 4b)(a - 2b)$       32.  $(x + xy + y)(x - y)$   
 33.  $(6x - 3y)(x + 6y)$       34.  $(5y + x)(4y - 2x)$   
 35.  $(7y^2 + x)(y^2 - 5x)$       36.  $(y^2 + x)(3y^2 - 7x)$   
 37.  $(6xy^2 - 3x + 4y)(x^2y + 6xy)$       38.  $(2xy^2 + 4y - 6x)(x^2y - 5xy)$

Use a special product formula to perform the indicated operations. See Example 5.

39.  $(3a + b)^2$       40.  $(x - 5y)^2$   
 41.  $(2x - 3y)(2x + 3y)$       42.  $(x - 3y)^2$   
 43.  $(-x - 2y)^2$       44.  $(\sqrt{2x} - \sqrt{3y})(\sqrt{2x} + \sqrt{3y})$   
 45.  $\left(\frac{1}{x} - y\right)\left(\frac{1}{x} + y\right)$       46.  $[(x - y) - z][(x - y) + z]$

Factor each polynomial by factoring out the greatest common factor. See Example 6.

47.  $4m^2n + 16m^3 + 7m$       48.  $3a^2b + 3a^3b - 9a^2b^2$   
 49.  $5(a - b^2) + (a - b^2)$       50.  $3x^3y - 9x^4y + 12x^3y^2$   
 51.  $2x^6 - 14x^3 + 8x$       52.  $27x^7y + 9x^6y - 9x^4yz$   
 53.  $(x^3 - y)^2 - (x^3 - y)$       54.  $6xy^3 + 9y^3 - 12xy^4$   
 55.  $12y^6 - 8y^2 - 16y^5$       56.  $(2x + y^2)^4 - (2x + y^2)^6$

Factor each polynomial by grouping. See Example 7.

57.  $a^3 + ab - a^2b - b^2$       58.  $ax - 2bx - 2ay + 4by$   
 59.  $z + z^2 + z^3 + z^4$       60.  $x^2 + 3xy + 3y + x$   
 61.  $nx^2 - 2y - 2x^2 + ny$       62.  $2ac - 3bd + bc - 6ad$   
 63.  $ax - 5bx + 5ay - 25by$       64.  $3ac - 5bd + bc - 15ad$

Use the special factoring patterns to factor the following binomials. See Example 8.

65.  $4x^2 - 121$

66.  $64z^3 + 216$

67.  $49a^2 - 144b^2$

68.  $x^3 - 27y^3$

69.  $25x^4y^2 - 9$

70.  $27a^9 + 8b^{12}$

71.  $x^3 - 1000y^3$

72.  $64x^6 - 125y^3z^9$

73.  $m^6 + 125n^9$

74.  $49a^6 - 9b^2c^4$

75.  $27x^6 - 8y^{12}z^3$

76.  $(3x-6)^2 - (y-2x)^2$

77.  $16z^2y^4 - 9x^8$

78.  $512x^6 + 729y^3$

79.  $343y^9 - 27x^3z^6$

80.  $(2x+y^2)^2 - (y^2-3)^2$

Factor the following trinomials. See Examples 9, 10, and 11.

81.  $x^2 + 2x - 15$

82.  $x^2 + 6x + 9$

83.  $x^2 - 2x + 1$

84.  $x^2 - 5x + 6$

85.  $x^2 - 4x + 4$

86.  $x^2 + 5x + 4$

87.  $y^2 + 14y + 49$

88.  $x^2 - 3x - 18$

89.  $x^2 + 13x + 22$

90.  $y^2 + y - 42$

91.  $y^2 - 9y + 8$

92.  $6x^2 + 5x - 6$

93.  $5a^2 - 37a - 24$

94.  $25y^2 + 10y + 1$

95.  $5x^2 + 27x - 18$

96.  $6y^2 - 13y - 8$

97.  $16y^2 - 25y + 9$

98.  $10m^2 + 29m + 10$

99.  $8a^2 - 2a - 3$

100.  $20y^2 + 21y - 5$

101.  $12y^2 - 19y + 5$

102.  $10y^2 - 11y - 6$

Factor the following algebraic expressions. See Example 12.

103.  $(2x-1)^{\frac{3}{2}} + (2x-1)^{\frac{1}{2}}$

104.  $2x^{-2} + 3x^{-1}$

105.  $7a^{-1} - 2a^{-3}b$

106.  $(3z+2)^{\frac{5}{3}} - (3z+2)^{\frac{2}{3}}$

107.  $10y^{-2} - 2y^{-5}x$

108.  $4y^{-3} + 12y^{-4}$

109.  $(5x+7)^{\frac{7}{3}} - (5x+7)^{\frac{4}{3}}$

110.  $(8x+6)^{\frac{7}{2}} - (8x+6)^{-\frac{1}{2}}$

111.  $7y^{-1} + 5y^{-4}$

112.  $5x^{-4} - 4x^{-5}y$

 WRITING & THINKING

- 113.** Pneumothorax is a disease in which air or gas collects between the lung and the chest wall, causing the lung to collapse. When this disease is evident, the following formula is used to determine the degree of collapse of the lungs, represented as a percent:

$$\text{Degree} = 100 \left( 1 - \frac{L^3}{H^3} \right)$$

In this formula,  $L$  is the diameter of one lung and  $H$  is the diameter of one hemithorax (or half the chest cavity). Is this formula a polynomial? If so, find its degree and the number of terms. If not, explain.

- 114.** You are trying to find a formula for the area of a certain trapezoid. You know the height of the trapezoid is  $x^2$ , the bottom base is  $2x^2 + 4$ , and the top base is  $6x + 2$ . Insert these values into the formula for the area of a trapezoid. Is the result a polynomial? If so, find the degree of the polynomial, the leading coefficient, and the number of terms in the polynomial. If not, explain.
- 115. a.** Given a rectangular picture frame with sides of  $2x + 1$  and  $x^3 + 4$ , find the area of the picture frame. Is the result a polynomial? If so, find the degree of the polynomial, the leading coefficient, and the number of terms in the polynomial. If not, explain.
- b.** Now find the perimeter of the picture frame. Is this a polynomial? If so, find the degree of the polynomial, the leading coefficient, and the number of terms in the polynomial. If not, explain.

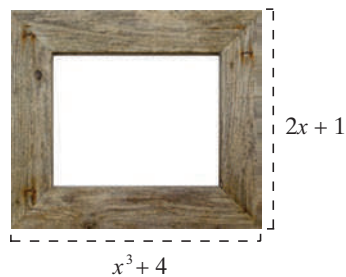

$$\begin{aligned}
 \text{b. } \frac{x^{-1} - y^{-1}}{x^{-2} - y^{-2}} &= \frac{\frac{1}{x} - \frac{1}{y}}{\frac{1}{x^2} - \frac{1}{y^2}} \\
 &= \frac{\frac{1}{x} - \frac{1}{y}}{\frac{1}{x^2} - \frac{1}{y^2}} \cdot \frac{x^2 y^2}{x^2 y^2} \\
 &= \frac{xy^2 - x^2 y}{y^2 - x^2} \\
 &= \frac{xy \cancel{(y-x)}}{\cancel{(y-x)}(y+x)} \\
 &= \frac{xy}{y+x}
 \end{aligned}$$

This expression is a complex rational expression, a fact that is more clear once we rewrite the terms that have negative exponents as fractions.

The LCD in this case is  $x^2 y^2$ , so we multiply top and bottom by this and factor the resulting polynomials.

We cancel the common factor of  $(y-x)$  to obtain the final simplified expression.

## 1.4 EXERCISES

### PRACTICE

Simplify the following rational expressions, indicating which real values of the variable must be excluded. See Example 1.

1.  $\frac{2x^2 + 7x + 3}{x^2 - 2x - 15}$
2.  $\frac{x^2 + 5x - 6}{x^3 + 2x^2 - 3x}$
3.  $\frac{x^3 + 2x^2 - 3x}{x + 3}$
4.  $\frac{x^2 - 4x + 4}{x^2 - 4}$
5.  $\frac{x^2 + 5x - 6}{x^2 + 4x - 5}$
6.  $\frac{2x^2 + 7x - 15}{x^2 + 3x - 10}$
7.  $\frac{x + 1}{x^3 + 1}$
8.  $\frac{x^3 + x}{3x^2 + 3}$
9.  $\frac{2x^2 + 11x + 5}{x + 5}$
10.  $\frac{x^4 - x^3}{x^2 - 3x + 2}$
11.  $\frac{2x^2 + 11x - 21}{x + 7}$
12.  $\frac{8x^3 - 27}{2x - 3}$

Add or subtract the rational expressions, as indicated, and simplify your answer. See Example 2.

13.  $\frac{x-3}{x+5} + \frac{x^2+3x+2}{x-3}$
14.  $\frac{x^2-1}{x-2} - \frac{x-1}{x+1}$
15.  $\frac{x+2}{x-3} - \frac{x-3}{x+5} - \frac{1}{x^2+2x-15}$
16.  $\frac{x+1}{x-3} + \frac{x^2+3x+2}{x^2-x-6} - \frac{x^2-2x-3}{x^2-6x+9}$
17.  $\frac{x^2+1}{x-3} + \frac{x-5}{x+3}$
18.  $\frac{x-37}{(x+3)(x-7)} + \frac{3x+6}{(x-7)(x+2)} - \frac{3}{x+3}$
19.  $\frac{x^2+2x-35}{x-5} + \frac{x-4}{x+3}$
20.  $\frac{y+2}{y-2} + \frac{y-6}{y+4} + \frac{4}{y^2+2y-8}$

$$21. \frac{x+2}{x-6} + \frac{x^2+5x+6}{x^2-3x-18} - \frac{x^2-4x-12}{x^2-12x+36} \quad 22. \frac{y^2+2}{y+3} - \frac{y-4}{y-3}$$

Multiply or divide the rational expressions, as indicated, and simplify your answer. See Example 3.

$$23. \frac{y-2}{y+1} \cdot \frac{y^2-1}{y-2} \quad 24. \frac{a^2-3a-4}{a-2} \div \frac{a^2-2a-8}{a-2}$$

$$25. \frac{2x^2-5x-12}{x-3} \cdot \frac{x^2-x-6}{x-4} \quad 26. \frac{z^2+2z+1}{2z^2+3z+1} \cdot \frac{2z^2-5z-3}{z+1}$$

$$27. \frac{y^2-11y+24}{y+6} \div \frac{y^2+5y-24}{y+6} \quad 28. \frac{y^2+8y+16}{5y^2+22y+8} \cdot \frac{5y^2-13y-6}{y+4}$$

$$29. \frac{5y^2-27y-18}{y-5} \cdot \frac{y^2-6y+5}{y-6} \quad 30. \frac{4z^2+20z-56}{z^2-8z+12} \div \frac{5z^2+43z+56}{15z^2-66z-144}$$

$$31. \frac{3b^2+9b-84}{b^2-5b+4} \div \frac{5b^2+37b+14}{-10b^2+6b+4}$$

$$32. \frac{3x^2-x-10}{x-1} \cdot \frac{x^2-1}{6x^2+x-15} \div \frac{x^2-x-2}{2x^2+5x-12}$$

Simplify the complex rational expressions. See Example 4.

$$33. \frac{\frac{3}{x} + \frac{x}{3}}{2 - \frac{1}{x}} \quad 34. \frac{\frac{1}{x} - \frac{1}{y}}{\frac{1}{x} + \frac{1}{y}} \quad 35. \frac{6x-6}{3 - \frac{3}{x^2}}$$

$$36. \frac{x^{-2} - y^{-2}}{y-x} \quad 37. \frac{\frac{1}{r} - \frac{1}{s}}{r + \frac{1}{r}} \quad 38. \frac{\frac{1}{x^2} - \frac{1}{y^2}}{\frac{1}{y^3} - \frac{1}{xy^2}}$$

$$39. \frac{\frac{m}{n} - \frac{n}{m}}{m-n} \quad 40. \frac{\frac{1}{y} - \frac{1}{x+3}}{\frac{1}{x} - \frac{y}{x^2+3x}} \quad 41. \frac{x+y^{-1}}{x^{-1}+y}$$

$$42. \frac{1+xy}{x^{-2}-y^2} \quad 43. \frac{x^2-y^2}{y^{-2}-x^{-2}} \quad 44. \frac{xy^{-1} + \left(\frac{x}{y}\right)^{-1}}{x^{-2} + y^{-2}}$$

$$45. \frac{\frac{1}{7y} + \frac{1}{x-2}}{\frac{1}{11x} + \frac{7y}{11x^2-22x}} \quad 46. \frac{8z+8}{2 - \frac{2}{z^2}} \quad 47. \frac{25x^{-2} - 9z^{-2}}{\frac{5z+3x}{x^2}}$$

$$48. \frac{\frac{3y}{5} - \frac{5}{3y}}{3 - \frac{5}{y}}$$

Perform the indicated operations on the following rational expressions, and simplify your answer.

$$49. \left( \frac{x^2 - 3x}{x^2 + 6x - 27} - \frac{2}{x + 9} \right) \cdot \frac{x + 9}{x + 2}$$

$$50. \frac{2y(y-1)}{y^2 + 6y - 16} \div \frac{2}{y+8} - \frac{2}{y-2}$$

$$51. \left( \frac{z^2 - 17z + 30}{z^2 + 2z - 8} + \frac{6}{z-2} \right) \div \frac{1}{z^2 - 5z - 36}$$

$$52. \frac{y+3}{2y+18} + \frac{y^2+2y+4}{y^2+3y-54} \cdot \frac{y-6}{y+3}$$

$$53. \frac{y^2+2y-15}{y+1} \cdot \left( \frac{y^2+3y+4}{y^2+3y-10} + \frac{y+4}{y+5} \right) \div \frac{y-3}{y-2}$$

$$54. \frac{y+6}{y-3} \left( \frac{y+5}{y-3} + \frac{y-3}{y+6} - \frac{y^2+4}{y^2+3y-18} \right)$$

**Example 5: Roots and Complex Numbers**

Simplify the following expressions.

a.  $(2 - \sqrt{-3})^2$

b.  $\frac{\sqrt{4}}{\sqrt{-4}}$

**Solution**

$$\begin{aligned} \text{a. } (2 - \sqrt{-3})^2 &= (2 - \sqrt{-3})(2 - \sqrt{-3}) \\ &= 4 - 4\sqrt{-3} + \sqrt{-3}\sqrt{-3} \\ &= 4 - 4i\sqrt{3} + (i\sqrt{3})^2 \\ &= 4 - 4i\sqrt{3} - 3 \\ &= 1 - 4i\sqrt{3} \end{aligned}$$

Each  $\sqrt{-3}$  is converted to  $i\sqrt{3}$  before multiplying.

$$\begin{aligned} \text{b. } \frac{\sqrt{4}}{\sqrt{-4}} &= \frac{2}{2i} \\ &= \frac{1}{i} \\ &= -i \end{aligned}$$

We simplify each radical before dividing.

We already simplified  $\frac{1}{i}$  in Example 4c, so we quickly obtain the correct answer of  $-i$ .**1.5 EXERCISES****PRACTICE**

Evaluate the following square root expressions. See Example 1.

1.  $\sqrt{-25}$

2.  $\sqrt{-12}$

3.  $-\sqrt{-27}$

4.  $-\sqrt{-100}$

5.  $\sqrt{-32x}$ ,  $x > 0$

6.  $\sqrt{-x^2}$

7.  $\sqrt{-29}$

8.  $(-i)^2\sqrt{-64}$

Simplify the following complex expressions. See Examples 2, 3, and 4.

9.  $(4 - 2i) - (3 + i)$

10.  $(4 - i)(2 + i)$

11.  $(3 - i)^2$

12.  $i^7$

13.  $(7i - 2) + (3i^2 - i)$

14.  $(3 + i)(3 - i)$

15.  $(5 - 3i)^2$

16.  $(5 + i)(2 - 9i)$

17.  $i^{13}$

18.  $(9 - 4i)(9 + 4i)$

19.  $11i^{314}$

20.  $i^{132}$

21.  $(7 - 3i)^2$

22.  $(4 - 3i)(7 + i)$

23.  $(3i)^2$

- |                         |                      |   |
|-------------------------|----------------------|---|
| 24. $(1+i)+i$           | 25. $i(5-i)$         | 26. $i^{-11}\left(\frac{6}{i^3}\right)$ |
| 27. $(10i^2-9i)+(9+5i)$ | 28. $(-5i)^3$        | 29. $i^7\left(\frac{49}{7i^2}\right)$   |
| 30. $\frac{1+2i}{1-2i}$ | 31. $\frac{10}{3-i}$ | 32. $\frac{i}{2+i}$                     |
| 33. $\frac{1}{i^9}$     | 34. $(2+5i)^{-1}$    | 35. $i^{-25}$                           |
| 36. $\frac{1}{i^{27}}$  | 37. $\frac{52}{5+i}$ | 38. $(2-3i)^{-1}$                       |
| 39. $\frac{4i}{5+7i}$   | 40. $i^{-4}$         | 41. $\frac{5+i}{4+i}$                   |

Simplify the following expressions. See Example 5.

- |                                |                              |                                      |
|--------------------------------|------------------------------|--------------------------------------|
| 42. $(3+\sqrt{-2})^2$          | 43. $(1+\sqrt{-6})^2$        | 44. $\frac{\sqrt{18}}{\sqrt{-2}}$    |
| 45. $(\sqrt{-32})(-\sqrt{-2})$ | 46. $(\sqrt{-9})(\sqrt{-2})$ | 47. $\frac{\sqrt{-98}}{3i\sqrt{-2}}$ |
| 48. $(\sqrt{-8})(\sqrt{-2})$   | 49. $(5+\sqrt{-3})^2$        | 50. $\frac{\sqrt{-72}}{5i\sqrt{-2}}$ |

### APPLICATIONS

51. Electrical engineers often use  $j$ , rather than  $i$ , to represent imaginary numbers. This is to prevent confusion with their use of  $i$ , which often represents current. Under this convention, assume the impedance of a particular part of a series circuit is  $4-3j$  ohms and the impedance of another part of the circuit is  $2+6j$  ohms. Find the total impedance of the circuit. (Impedances in series are simply added.)
52. Consider the formula  $V = IZ$ , where  $V$  is voltage (in volts),  $I$  is current (in amps), and  $Z$  is impedance (in ohms). If you know the current of a circuit is  $5-4j$  amps and the impedance is  $8+2j$  ohms, find the voltage.
53. If you know the voltage of a circuit is  $35+5j$  volts and the current is  $3+j$  amps, find the impedance.

### WRITING & THINKING

54. Explain why it may be useful to be able to use imaginary numbers in real-world math.

 TECHNOLOGY

Use a graphing utility to simplify the following complex expressions.

55.  $\frac{3-2i}{1+i}$

56.  $(3-2i)^4$

57.  $\frac{2500}{(3+i)^4}$

58.  $(2-5i)(3+7i)(1-4i)$

59.  $(1+i)^5(3-i)^2$

60.  $\frac{3+7i}{(2-5i)(1+3i)}$

61.  $\frac{6+3i}{2-4i}$

62.  $(5-3i)^5$

63.  $\frac{400}{(6+2i)^3}$

64.  $(6-3i)(8+i)(7-4i)$

65.  $(5-3i)^4(7+2i)^3$

66.  $\frac{4+3i}{(7-2i)(5+4i)}$

## 1.6 EXERCISES

### PRACTICE

Solve the following linear equations. See Examples 1 and 2.

1.  $-3(2t - 4) = 7(1 - t)$

2.  $5(2x - 1) = 3(1 - x) + 5x$

3.  $\frac{y + 5}{4} = \frac{1 - 5y}{6}$

4.  $3x + 5 = 3(x + 3) - 4$

5.  $3w + 5 = 2(w + 3) - 4$

6.  $3x + 5 = 3(x + 3) - 5$

7.  $\frac{4s - 3}{2} + \frac{7}{4} = \frac{8s + 1}{4}$

8.  $\frac{4x - 3}{2} + \frac{3}{8} = \frac{7x + 3}{4}$

9.  $\frac{4z - 3}{2} + \frac{3}{8} = \frac{8z + 3}{4}$

10.  $3(2w + 13) = 5w + w\left(7 - \frac{3}{w}\right)$

11.  $\frac{6}{7}(m - 4) - \frac{11}{7} = 1$

12.  $0.08p + 0.09 = 0.65$

13.  $0.6x + 0.08 = 2.3$

14.  $0.9x + 0.5 = 1.3x$

15.  $0.73x + 0.42(x - 2) = 0.35x$

16.  $\frac{8y - 2}{4} + \frac{6}{8} = \frac{16y + 2}{8}$

17.  $\frac{3}{7}(y - 2) - \frac{14}{7} = -5$

18.  $6(5w - 5) = -31(3 - w)$

19.  $\frac{7x - 5}{4} + \frac{14}{8} = \frac{14x + 4}{8}$

20.  $\frac{3}{11}(y - 2) - \frac{33}{11} = -6$

21.  $3z + 3 = 3(z + 4) - 9$

22.  $4y + 9 = 4(y + 4) - 10$

23.  $2.8x + 1.2 = 3.2x$

24.  $0.73z + 0.34 = 9.1$

25.  $0.24x + 0.58(x - 6) = 0.82x - 3.67$

Solve the following absolute value equations. See Example 3.

26.  $|3x - 2| = 5$

27.  $-|3y + 5| + 6 = 2$

28.  $|4x + 3| + 2 = 0$

29.  $|6x - 2| = 0$

30.  $|-8x + 2| = 14$

31.  $|2x - 109| = 731$

32.  $|4x - 4| - 40 = 0$

33.  $|5x - 3| = 7$

34.  $|4x + 15| = 3$

35.  $-|6x + 1| = 11$

36.  $|-14y + 3| + 3 = 2$

37.  $|3x - 2| - 1 = |5 - x|$

Solve the following absolute value equations geometrically and algebraically. See Figure 1.

38.  $|x + 3| = |x - 7|$

39.  $|x - 3| - |x - 7| = 0$

40.  $|2 - x| = |2 + x|$

41.  $|x| = |x + 1|$

42.  $|x + 97| = |x + 101|$

43.  $\left|x + \frac{1}{4}\right| = \left|x - \frac{3}{4}\right|$

44.  $|z - 51| - |z - 5| = 0$

45.  $\left|x - \frac{5}{7}\right| = \left|x + \frac{3}{7}\right|$

46.  $|6y - 3| = |5y + 5|$

Solve each of the following equations for the indicated variable. See Example 4.

47. Circumference of a circle:  $C = 2\pi r$ ; solve for  $r$
48. Ideal Gas Law:  $PV = nRT$ ; solve for  $T$
49. Velocity:  $v^2 = v_0^2 + 2ax$ ; solve for  $a$
50. Area of a trapezoid:  $A = \frac{1}{2}h(b+c)$ ; solve for  $h$
51. Temperature conversions:  $C = \frac{5}{9}(F-32)$ ; solve for  $F$
52. Volume of a right circular cone:  $V = \frac{1}{3}\pi r^2 h$ ; solve for  $h$
53. Surface area of a rectangular prism:  $A = 2lw + 2wh + 2hl$ ; solve for  $h$
54. Distance:  $d = rt_1 + rt_2$ ; solve for  $r$
55. Kinetic energy of protons:  $K = \frac{1}{2}mv^2$ ; solve for  $m$
56. Finance:  $A = P(1+rt)$ ; solve for  $t$

### APPLICATIONS

57. A riverboat leaves port and proceeds to travel downstream at an average speed of 15 miles per hour. How long will it take for the boat to arrive at the next port, 95 miles downstream?
58. Two trucks leave a warehouse at the same time. One travels due east at an average speed of 45 miles per hour, and the other travels due west at an average speed of 55 miles per hour. After how many hours will they be 450 miles apart?
59. Two cars leave a rest stop at the same time and proceed to travel down the highway in the same direction. One travels at an average rate of 62 miles per hour, and the other at an average rate of 59 miles per hour. How far apart are the two cars after four and a half hours?
60. Two trains are 630 miles apart, heading directly toward each other on parallel tracks. The first train is traveling at 95 mph, and the second train is traveling at 85 mph. How long will it be before the trains pass each other?
61. Two brothers, Rick and Tom, each inherit \$10,000. Rick invests his inheritance in a savings account with an annual return of 2.25%, while Tom invests his in a CD paying 6.15% annually. How much more money does Tom have than Rick after 1 year?
62. Sarah, sister to Rick and Tom in the previous problem, also inherits \$10,000, but she invests her inheritance in a global technology mutual fund. At the end of 1 year, her investment is worth \$12,800. What has her effective annual rate of return been?

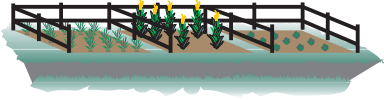
63. An industrial acid-etching procedure calls for 3 gallons of a 46% hydrofluoric acid solution, but the supplier currently only has 44% solution and 50% solution. How many gallons of each should be mixed for the procedure?
64. An agricultural stress test calls for soaking seeds in 8% saline solution. The scientist running the test wants to make use of 1 liter of 20% saline solution that is already made up. How much pure water should she add to the 20% solution to obtain an 8% solution?
65. A total of 39 tickets were sold for a puppet show, with child tickets selling for \$7.50 and adult tickets selling for \$10.00. The ticket sales raised \$330.00 in all. How many child tickets and how many adult tickets were sold?
66. Joe's Java Joint wants to make a blend of two coffees that can be sold for \$15 per pound. The first of the two types of coffee costs \$18 per pound, while the second costs \$13 per pound. How many pounds of each should be mixed to get 10 pounds of the desired blend?
67. Bob buys a large screen digital TV priced at \$9,500, but pays \$10,212.50 with tax. What is the rate of tax where Bob lives?
68. Will and Matt are brothers. Will is 6 feet, 4 inches tall, and Matt is 6 feet, 7 inches tall. How tall is Will as a percentage of Matt's height? How tall is Matt as a percentage of Will's height?
69. A farmer wants to fence in three square garden plots situated along a road, as shown, and he decides not to install fencing along the edge of the road. If he has 182 feet of fencing material total, what dimensions should he make each square plot?
- 
70. Find three consecutive integers whose sum is 288. (**Hint:** If  $n$  represents the smallest of the three, then  $n + 1$  and  $n + 2$  represent the other two numbers.)
71. Find three consecutive odd integers whose sum is 165. (**Hint:** If  $n$  represents the smallest of the three, then  $n + 2$  and  $n + 4$  represent the other two numbers.)
72. Kathy buys last year's best-selling novel, in hardcover, for \$15.05. This is a 30% discount from the original price. What was the original price?
73. The highest point on Earth is the peak of Mount Everest. If you climbed to the top, you would be approximately 29,035 feet above sea level. Remembering that a mile is 5280 feet, what percentage of the height of the mountain would you have to climb to reach a point two miles above sea level?

### TECHNOLOGY

Use a graphing utility to solve the following equations. Round your answers to two decimal places if necessary.

74.  $453x = 95(34x + 291)$

75.  $-0.23 = 0.79x - 0.47(x + 0.98)$

76.  $254 + 0.98(x - 124) = 0$

77.  $323x - 1745 = 531(68x - 887)$

## 1.7 EXERCISES

## PRACTICE

Determine which elements of  $S = \{12, -9, 3.14, -2.83, 1, 5.24, 8, -3, 4\}$  satisfy each inequality below.

1.  $7y - 33.6 < -8.6 + 2y$
2.  $-2.2y - 18.8 \geq 5.2(1 - y)$
3.  $-40 < 4y - 8 \leq 4$
4.  $-4 < -2(z - 2) \leq 2$

Solve the following linear inequalities. Describe the solution set using interval notation and by graphing. See Examples 2 and 3.

5.  $4 + 3t \leq t - 2$
6.  $x - 7 \geq 5 + 3x$
7.  $5y - 24 < -9.6 + 2y$
8.  $-\frac{v+2}{3} > \frac{5-v}{2}$
9.  $4.2x - 5.6 < 1.6 + x$
10.  $8.5y - 3.5 \geq 2.5(3 - y)$
11.  $-2(3 - x) < -2x$
12.  $\frac{1-x}{5} > \frac{-x}{10}$
13.  $4w + 7 \leq -7w + 4$
14.  $-5(p - 3) > 19.8 - p$
15.  $\frac{6f - 2}{5} < \frac{5f - 3}{4}$
16.  $\frac{u - 6}{7} \geq \frac{2u - 1}{3}$
17.  $0.04n + 1.7 < 0.13n - 1.45$
18.  $2k + \frac{3}{2} < 5k - \frac{7}{3}$
19.  $\frac{4x + 4}{5} > \frac{3x + 2.6}{4}$
20.  $-1.4z - 19.6 \geq 4.4(1 - z)$
21.  $6m + \frac{7}{4} > \frac{4m + 5.8}{5}$
22.  $-3.9n - 5.4 \geq 6.2(2 - 3n)$

Solve the following double inequalities. Describe the solution set using interval notation and by graphing. See Examples 4 and 5.

23.  $-4 < 3x - 7 \leq 8$
24.  $5 \leq 2m - 3 \leq 13$
25.  $-36 < 3x - 6 \leq 12$
26.  $2 < 3(x + 2) \leq 21$
27.  $-8 \leq \frac{z}{2} - 4 < -5$
28.  $6(x - 1) < 2(3x + 5) \leq 6x + 10$
29.  $3 < \frac{w + 3}{8} \leq 9$
30.  $4 \leq \frac{p + 7}{-2} < 9$
31.  $\frac{1}{3} < \frac{7}{6}(l - 3) < \frac{2}{3}$
32.  $-10 < -2(4 + y) \leq 9$
33.  $\frac{1}{4} \leq \frac{g}{2} - 3 < 5$
34.  $-1.2 \leq \frac{x + 3}{-5} \leq 0.2$
35.  $0.08 < 0.03c + 0.13 \leq 0.16$

Solve the following absolute value inequalities. Describe the solution set using interval notation and by graphing. See Example 6.

36.  $|x-2| \geq 5$                       37.  $|4-2x| > 11$                       38.  $4+|3-2y| \leq 6$
39.  $4+|3-2y| > 6$                       40.  $2|z+5| < 12$                       41.  $7-\left|\frac{q}{2}+3\right| \geq 12$
42.  $4|z+3| \leq 28$                       43.  $-3|4-t| < -6$                       44.  $-3|4-t| > -6$
45.  $3|4-t| < -6$                                       46.  $7-|4-2y| \leq -5$
47.  $11-\left|\frac{w}{4}+1\right| \geq 12$                                       48.  $5.5+|x-7.2| \leq 3.5$
49.  $6-5|x+2| \geq -4$                                       50.  $|2x-1| < x+4$
51.  $|3t+4| > -8$                                       52.  $2 < |6w-2|+7$

The words “and” and “or” can appear explicitly between two inequalities, and their meaning in such cases is the same as in absolute value inequalities. If two inequalities are joined by the word “and,” the solution set consists of all those real numbers that satisfy both inequalities; that is, the solution set overall is the intersection of the two individual solution sets. If the word “or” appears between two inequalities, the solution set consists of all those real numbers that satisfy at least one of the two inequalities; in other words, the solution set overall is the union of the two individual solution sets.

Guided by the above paragraph, solve the following inequality problems. Describe the solution set using interval notation and by graphing.

53.  $t < 2t-3$  and  $-3(t+4) > -57$                       54.  $7-\frac{3x}{5} < \frac{2}{5}$  or  $2-3x \geq 5$
55.  $-2(a-1) < 4$  and  $6+a \leq 9$                       56.  $-2(a-1) < 4$  and  $6-a \leq 9$
57.  $-2(a-1) < 4$  or  $6+a \leq 9$                       58.  $\frac{5n+6}{3} < -10$  and  $-3(n-1) < -6$
59.  $\frac{23x-3}{-7} \leq 7$  and  $-x < -(4x-9)$                       60.  $7-\frac{x}{3} \leq 14+\frac{x}{2}$  or  $-3x < 15$

### APPLICATIONS

61. In a class in which the final course grade depends entirely on the average of four equally weighted 100-point tests, Cindy has scored 96, 94, and 97 on the first three. The professor has announced that there will be a 15-point bonus problem on the fourth test, and anyone who finishes the semester with an average of more than 100 will receive an A+. What interval of scores on the fourth test will give Cindy an A for the semester (an average between 90 and 100, inclusive), and what interval will give Cindy an A+?

62. In a series of 30 racquetball games played to date, Larry has won 10, giving him a winning average so far of 33.3% (to the nearest tenth of a percent). If he continues to play, what interval describes the number of games he must now win in a row to have an overall winning average greater than 50%?
63. Assume that the national average SAT score for high school seniors is 1020 out of 1600. A group of seven students receive their scores in the mail, and six of them look at their scores. Two students scored 1090, one got an 1120, two others each got a 910, and the sixth student received an 880. What interval of scores can the seventh student receive to pull the group's average above the national average?
64. The central bank of a certain country tries to keep the inflation rate below 5.0% on an annual basis. Assume that inflation rates for the first three quarters of a given year are as follows: 5.2%, 4.3%, and 4.7%. What interval of inflation rates for the final quarter would satisfy the government's goal?

**Example 11: Solving Equations by Factoring**

Solve the equation  $x^{-2} - 7x^{-1} + 12 = 0$  by factoring.

**Solution**

While the given equation is not quadratic, it certainly bears a strong resemblance to one that is. In fact, if we make the substitution  $y = x^{-1}$ , we obtain the quadratic equation

$$y^2 - 7y + 12 = 0,$$

which we can solve by factoring the trinomial as  $(y-3)(y-4)$ . This gives us  $y = 3$  or  $y = 4$ . Translating this back to the variable  $x$ , we have  $x^{-1} = 3$  or  $x^{-1} = 4$ , so  $x = \frac{1}{3}$  or  $x = \frac{1}{4}$ .

**1.8 EXERCISES****PRACTICE**

Solve the following quadratic equations by factoring. See Example 1.

- |                                    |                             |
|------------------------------------|-----------------------------|
| 1. $2x^2 - x = 3$                  | 2. $x^2 - 14x + 49 = 0$     |
| 3. $y(2y+9) = -9$                  | 4. $3x^2 + 33 = 2x^2 + 14x$ |
| 5. $5x^2 + 2x + 3 = 4x^2 + 6x - 1$ | 6. $(x-7)^2 = 16$           |
| 7. $4x^2 - 9 = 0$                  |                             |

Solve the following quadratic equations by taking square roots. See Example 2.

- |                        |                         |
|------------------------|-------------------------|
| 8. $(x-3)^2 = 9$       | 9. $(a-2)^2 = -5$       |
| 10. $(y-18)^2 - 1 = 0$ | 11. $9 = (3s+2)^2$      |
| 12. $(2x-1)^2 = 8$     | 13. $x^2 - 4x + 4 = 49$ |

Solve the following quadratic equations by completing the square. See Example 3.

- |                            |                           |
|----------------------------|---------------------------|
| 14. $x^2 + 8x + 7 = -8$    | 15. $2x^2 + 6x - 10 = 10$ |
| 16. $2x^2 + 7x - 15 = 0$   | 17. $4x^2 - 4x - 63 = 0$  |
| 18. $4x^2 - 56x + 195 = 0$ | 19. $y^2 + 22y + 96 = 0$  |

Solve the following quadratic equations using the quadratic formula. See Example 4.

20.  $3x^2 - 4 = -x$

21.  $2.6z^2 - 0.9z + 2 = 0$

22.  $a(a+2) = -1$

23.  $3x^2 - 2x = 0$

24.  $6x^2 + 5x - 4 = 3x - 2$

25.  $4x^2 - 14x - 27 = 3$

Calculate the discriminant and use it to determine the number and type of solutions of the following quadratic equations. See Example 5.

26.  $2x^2 - x + 5 = 0$

27.  $x^2 + x - 5 = 0$

28.  $-3x^2 - 2x + 2 = 0$

29.  $2x^2 - 4x + 2 = 0$

Solve the following quadratic equations using any appropriate method. See Example 6.

30.  $y^2 + 9y = -40.50$

31.  $(z-11)^2 = 9$

32.  $256t^2 - 324 = 0$

33.  $(9y-6)^2 = 121y^2$

34.  $2x^2 + 8x - 3 = 6x$

35.  $4z^2 + 14z = 10z - 3$

36.  $x^2 - 6x = 27$

37.  $y^2 - 2y + 1 = -289$

38.  $-3(b+5)^2 = -768$

39.  $7x^2 - 42x = 0$

40.  $5x^2 - 5x - 10 = 0$

41.  $4w^2 + 10w + 5 = 3w^2 + 18w - 10$

42.  $|x^2 - 3x| = 2$  (**Hint:** Replace  $|x^2 - 3x|$  first with  $x^2 - 3x$  and solve the resulting equation, then replace it with  $-(x^2 - 3x)$  and solve the resulting equation.)

43.  $|x^2 - x| = 2$

44.  $|x^2 - 8| = 1$

Solve the following quadratic-like equations. See Example 8.

45.  $(x-1)^2 + (x-1) - 12 = 0$

46.  $(y-5)^2 - 11(y-5) + 24 = 0$

47.  $(x^2+1)^2 + (x^2+1) - 12 = 0$

48.  $(x^2-13)^2 + (x^2-13) - 12 = 0$

49.  $(x^2 - 2x + 1)^2 + (x^2 - 2x + 1) - 12 = 0$

50.  $2y^{\frac{2}{3}} + y^{\frac{1}{3}} - 1 = 0$

51.  $2x^{\frac{2}{3}} - 7x^{\frac{1}{3}} + 3 = 0$

52.  $(x^2 - 6x)^2 + 4(x^2 - 6x) - 5 = 0$

53.  $(y^2 - 5)^2 + 5(y^2 - 5) - 36 = 0$

54.  $(x^2 + 7)^2 + 8(x^2 + 7) + 12 = 0$

55.  $(t^2 - t)^2 - 8(t^2 - t) + 12 = 0$

56.  $2x^{\frac{1}{2}} - 5x^{\frac{1}{4}} + 2 = 0$

57.  $3x^{\frac{2}{3}} - x^{\frac{1}{3}} - 2 = 0$

58.  $5y^{\frac{2}{3}} + 33y^{\frac{1}{3}} + 18 = 0$

Solve the following polynomial equations by factoring. See Example 9.

59.  $a^3 - 3a^2 = a - 3$

60.  $2x^3 + x^2 + 2x + 1 = 0$

61.  $x^4 + 5x^2 - 36 = 0$

62.  $y^3 + 8 = 0$

63.  $5s^3 + 6s^2 - 20s = 24$

64.  $8a^3 - 27 = 0$

65.  $16a^4 = 81$

66.  $6x^3 + 8x^2 = 14x$

67.  $14x^3 + 27x^2 - 20x = 0$

68.  $5z^3 + 28z^2 = 49z$

69.  $27x^3 + 64 = 0$

70.  $x^3 - 4x^2 + x = 4$

Solve the following equations by factoring. See Examples 10 and 11.

71.  $3x^{\frac{11}{3}} + 2x^{\frac{8}{3}} - 5x^{\frac{5}{3}} = 0$

72.  $(y-6)^{\frac{-5}{2}} + 7(y-6)^{\frac{-3}{2}} = 0$

73.  $y^{-2} - 2y^{-1} + 1 = 0$

74.  $2x^{\frac{13}{5}} - 5x^{\frac{8}{5}} + 2x^{\frac{3}{5}} = 0$

75.  $(2x-5)^{\frac{1}{3}} - 3(2x-5)^{\frac{-2}{3}} = 0$

76.  $x^{-4} - 13x^{-2} + 36 = 0$

77.  $y^{\frac{7}{2}} - 5y^{\frac{5}{2}} + 6y^{\frac{3}{2}} = 0$

78.  $(t+4)^{\frac{2}{3}} + 2(t+4)^{\frac{8}{3}} = 0$

79.  $y^{-2} - 2y^{-1} - 35 = 0$

80.  $x^{\frac{11}{2}} - 6x^{\frac{9}{2}} + 9x^{\frac{7}{2}} = 0$

81.  $5y^{\frac{11}{3}} + 3y^{\frac{8}{3}} - 2y^{\frac{5}{3}} = 0$

82.  $(3x-3)^{\frac{-1}{3}} - 5(3x-3)^{\frac{-4}{3}} = 0$

83.  $x^{-2} + 8x^{-1} + 15 = 0$

84.  $(y+3)^{\frac{2}{5}} + 4(y+3)^{\frac{7}{5}} = 0$

### 🚀 APPLICATIONS

85. How long would it take for a ball dropped from the top of a 144-foot building to hit the ground?

86. Suppose that instead of being dropped, as in Exercise 85, a ball is thrown upward with a velocity of 40 feet per second from a height of 144 feet. Assuming it misses the building on the way back down, how long after being thrown will it hit the ground?

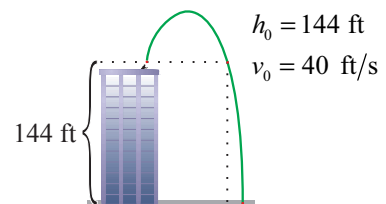

87. A slingshot is used to shoot a BB at a velocity of 96 feet per second straight up from ground level. When will the BB reach its maximum height of 144 feet?

88. A rock is thrown off a cliff with a velocity of 20 meters per second. It is thrown upward from a height of 24 meters and misses the cliff on the way back down. When will the rock be 7 meters from ground level? (Round your answer to one decimal place.)

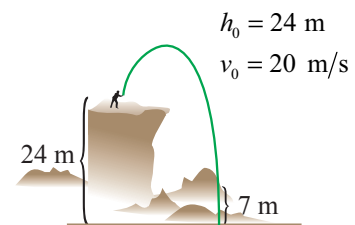

89. Luke, an experienced bungee jumper, leaps from a tall bridge and falls toward the river below. The bridge is 170 feet above the water and Luke's bungee cord is 110 feet long unstretched. When will Luke's cord begin to stretch? (Round your answer to one decimal place.)

 **WRITING & THINKING**

90. Compare the answers to Exercises 85 and 87 and explain why they are the same.

Use the connection between solutions of polynomial equations and polynomial factoring to answer the following questions. See the discussion after Example 3.

91. Factor the quadratic  $x^2 - 6x + 13$ .
92. Factor the quadratic  $9x^2 - 6x - 4$ .
93. Factor the quadratic  $4x^2 + 12x + 1$ .
94. Factor the quadratic  $25x^2 - 10x + 2$ .
95. Determine  $b$  and  $c$  so that the equation  $x^2 + bx + c = 0$  has the solution set  $\{-3, 8\}$ .
96. Find  $b$ ,  $c$ , and  $d$  so the equation  $x^3 + bx^2 + cx + d = 0$  has solutions of  $-3$ ,  $-1$ , and  $5$ .
97. Find  $b$ ,  $c$ , and  $d$  so the equation  $x^3 + bx^2 + cx + d = 0$  has solutions of  $-2$ ,  $0$ , and  $6$ .
98. Find  $b$  and  $c$  so the equation  $x^3 + bx^2 + cx = 0$  has solutions of  $0$ ,  $1$ , and  $-7$ .
99. Find  $a$ ,  $c$ , and  $d$  so the equation  $ax^3 + 4x^2 + cx + d = 0$  has solutions of  $-4$ ,  $6$ , and  $-6$ .
100. Find  $a$ ,  $b$ , and  $d$  so the equation  $ax^3 + bx^2 + 3x + d = 0$  has solutions of  $-3$ ,  $-\frac{1}{2}$ , and  $0$ .
101. Find  $a$ ,  $b$ , and  $c$  so the equation  $ax^3 + bx^2 + cx + 6 = 0$  has solutions of  $-\frac{3}{5}$ ,  $\frac{2}{3}$ , and  $1$ .

 **TECHNOLOGY**

Use a graphing utility to solve the following polynomial equations.

102.  $5x^2 - 3x = 17$
103.  $5x^2 - 3x = -17$
104.  $(a + 4)(4a - 3) = 5$
105.  $10\pi r + \pi r^2 = 107$
106.  $4.8x^2 + 3.5x - 9.2 = 0$
107.  $(3x - 1)(3 - x) = 2x + 5$

**Example 8: Escape Speed**

The speed required for an object to escape from the gravitational pull of a planet is called the **escape speed** of the planet. The escape speed is given by the equation

$v_e = \sqrt{\frac{2GM}{r}}$ , where  $v_e$  is the escape speed,  $G$  is the universal gravitation constant,  $M$  is the mass of the planet, and  $r$  is the radius of the planet. Solve this equation for  $r$ .

**Solution**

We follow the same procedure for solving radical equations.

$$v_e = \sqrt{\frac{2GM}{r}} \quad \text{The radical expression is already isolated.}$$

$$v_e^2 = \frac{2GM}{r} \quad \text{Square both sides to eliminate the radical.}$$

$$r = \frac{2GM}{v_e^2} \quad \text{Solve for } r.$$

**1.9 EXERCISES****PRACTICE**

Solve the following rational equations. See Examples 1 and 2.

1. 
$$\frac{2x^3 + 4x^2}{x^2 - 4x - 12} = \frac{-7x - 6}{x - 6}$$

2. 
$$\frac{-x^2}{x - 1} - 3 = 0$$

3. 
$$\frac{3}{x - 2} + \frac{2}{x + 1} = 1$$

4. 
$$\frac{x}{x - 1} + \frac{2}{x - 3} = -\frac{2}{x^2 - 4x + 3}$$

5. 
$$\frac{1}{t - 3} + \frac{1}{t + 2} = \frac{1}{t + 3}$$

6. 
$$\frac{z}{6 + z} + \frac{z - 1}{6 - z} = \frac{z}{6 - z}$$

7. 
$$\frac{y}{y - 1} + \frac{2}{y - 3} = \frac{y^2}{y^2 - 4y + 3}$$

8. 
$$\frac{2}{2x + 1} - \frac{x}{x - 4} = \frac{-3x^2 + x - 4}{2x^2 - 7x - 4}$$

9. 
$$\frac{2}{2b + 1} + \frac{2b^2 - b + 4}{2b^2 - 7b - 4} = \frac{b}{b - 4}$$

10. 
$$\frac{2}{n + 3} + \frac{3}{n + 2} = \frac{6}{n}$$

11. 
$$\frac{1}{x - 3} + \frac{1}{x + 3} = \frac{2x}{x^2 - 9}$$

12. 
$$\frac{3}{x - 1} - \frac{3}{x + 2} = \frac{9}{x^2 + x - 2}$$

13. 
$$\frac{1}{|x - 3|} = 2$$

14. 
$$\frac{3}{|x + 1|} = 1$$

15. 
$$\frac{1}{|x - 3|} + \frac{1}{|x + 1|} = 1$$

16. 
$$\frac{1}{x - 2} + \frac{2}{|x - 1|} = 2$$

Solve the following radical equations. See Example 6.

17.  $\sqrt{4-x} - x = 2$

18.  $\sqrt{3y+4} + \sqrt{5y+6} = 2$

19.  $\sqrt{3-3x} - 3 = \sqrt{3x+2}$

20.  $\sqrt{x^2-4x+5} - x + 2 = 0$

21.  $\sqrt{x^2-4x+4} + 2 = 3x$

22.  $\sqrt{50+7s} - s = 8$

23.  $\sqrt[3]{3-2x} - \sqrt[3]{x+1} = 0$

24.  $\sqrt[4]{x^2-x} = \sqrt[4]{x-1}$

25.  $\sqrt[4]{2x+3} = -1$

26.  $\sqrt{11x+3} + 4x = 18$

27.  $\sqrt{2b-1} + 3 = \sqrt{10b-6}$

28.  $\sqrt{5x+5} = \sqrt{4x-7} + 2$

29.  $\sqrt{x+10} + 1 = x - 1$

30.  $\sqrt{x+1} + 10 = x - 1$

31.  $\sqrt{x^2-10} - 1 = x + 1$

32.  $\sqrt[3]{5x^2-14x} = -2$

33.  $\sqrt[5]{7t^2+2t} = \sqrt[5]{5t^2+4}$

34.  $\sqrt[3]{y^3-7y+2} = \sqrt[3]{2-3y}$

35.  $\sqrt{14y^2-18y+4} + 2 = 2y$

36.  $\sqrt{9x+4} = \sqrt{7x+1} + 1$

37.  $\sqrt{4z+41} + 3 = z + 2$

Solve the following equations. See Example 7.

38.  $(x+3)^{\frac{1}{4}} + 2 = 0$

39.  $(2x-5)^{\frac{1}{4}} = (x-1)^{\frac{1}{4}}$

40.  $(2x-1)^{\frac{2}{3}} = x^{\frac{1}{3}}$

41.  $(3y^2+9y-5)^{\frac{1}{2}} = y+3$

42.  $(3x-5)^{\frac{1}{5}} = (x+1)^{\frac{1}{5}}$

43.  $w^{\frac{3}{5}} + 8 = 0$

44.  $z^{\frac{4}{3}} - \frac{16}{81} = 0$

45.  $x^{\frac{2}{3}} - \frac{25}{49} = 0$

46.  $(x^2+21)^{\frac{-3}{2}} = \frac{1}{125}$

47.  $(x-2)^{\frac{2}{3}} = (14-x)^{\frac{1}{3}}$

48.  $(x^2+7)^{\frac{-3}{2}} = \frac{1}{64}$

49.  $(y-2)^{\frac{2}{3}} = (13y-66)^{\frac{1}{3}}$

Solve each of the following formulas for the indicated variable. See Example 8.

50. The formula  $T = 2\pi\sqrt{\frac{l}{g}}$  gives the period  $T$  of a pendulum of length  $l$ . Solve this formula for  $l$ .

51. The formula  $c = \sqrt{a^2+b^2}$  gives the length of the hypotenuse  $c$  of a right triangle. Solve this formula for  $a$ .

52. Einstein's Theory of Relativity states that  $E = mc^2$ . Solve this equation for  $c$ .

53. The formula  $\omega = \sqrt{\frac{k}{m}}$  gives the angular frequency  $\omega$  of a mass  $m$  suspended from a spring of spring constant  $k$ . Solve this formula for  $m$ .

54. The formula  $V = \frac{4}{3}\pi r^3$  gives the volume of a sphere with radius  $r$ . Solve the equation for  $r$ .
55. The formula  $F = \frac{mv^2}{r}$  gives the force on an object in circular motion. Solve the equation for  $v$ .
56. The formula for lateral acceleration, used in automobiles, is  $a = \frac{1.227r}{t^2}$ . Solve this equation for  $t$ .
57. According to one guideline regarding body mass index (BMI), a healthy mass for an adult male can be found using the formula  $m = 23h^2$ , where  $m$  is expressed in kilograms and  $h$  in meters. Solve this equation for  $h$ .
58. Kepler's Third Law is  $T^2 = \frac{4\pi^2 r^3}{GM}$ . It relates the period  $T$  of a planet to the radius  $r$  of its orbit and the sun's mass  $M$ . Solve this formula for  $r$ .
59. The equation  $r = \frac{2gm}{c^2}$  is the Schwarzschild Radius Formula used to find the radius of a black hole in space. Solve the equation for  $c$ .
60. The total mechanical energy of an object with mass  $m$  at height  $h$  in a closed system can be written as  $ME = \frac{1}{2}mv^2 + mgh$ . Solve for  $v$ , the velocity of the object, in terms of the given quantities.
61. Recall, the formula for the Pythagorean Theorem states that  $a^2 + b^2 = c^2$ . Solve this formula for  $b$ .
62. In a circuit with an AC power source, the total impedance  $Z$  depends on the resistance  $R$ , the capacitance  $C$ , the inductance  $L$ , and the frequency of the current  $\omega$  according to  $Z = \sqrt{R^2 + \left(\omega L - \frac{1}{\omega C}\right)^2}$ . Solve this equation for the inductance  $L$ .
63. The formula used to find the orbital period for circular Keplerian orbits is  $P = \frac{2\pi}{\sqrt{\frac{u}{a^3}}}$ . Solve this equation for  $a$ .

### APPLICATIONS

64. If Joanne were to paint her living room alone, it would take 5 hours. Her sister Lisa could do the job in 7 hours. How long would it take them working together?
65. The hot water tap can fill a given sink in 4 minutes. If the cold water tap is turned on as well, the sink fills in 1 minute. How long would it take for the cold water tap to fill the sink alone?

66. The hull of Jack's yacht needs to be cleaned. He can clean it by himself in 5 hours, but he asks his friend Thomas to help him. If it takes 3 hours for the two men to clean the hull of the boat, how long would it have taken Thomas alone?
67. Two hoses, one of which has a flow rate three times the other, can together fill a tank in 3 hours. How long does it take each of the hoses individually to fill the tank?
68. Officials begin to release water from a full man-made lake at a rate that would empty the lake in 12 weeks, but a river that can fill the lake in 30 weeks is replenishing the lake at the same time. How long does it take to empty the lake?
69. In order to flush deposits from a radiator, a drain that can empty the entire radiator in 45 minutes is left open at the same time it is being filled at a rate that would fill it in 30 minutes. How long does it take for the radiator to fill?
70. Jimmy and Janice are picking strawberries. Janice can fill a bucket in a half hour, but Jimmy continues to eat the strawberries that Janice has picked at a rate of one bucket per 1.5 hours. How long does it take Janice to fill her bucket?
71. A farmer can plow a given field in 2 hours less time than it takes his son. If they acquire two tractors and work together, they can plow the field in 5 hours. How long does it take the father alone? Round your answer to one decimal place.



**Solution**

$$\text{a. } \left( \frac{5+(-1)}{2}, \frac{1+3}{2} \right) = (2, 2)$$

$$\text{b. } \left( \frac{3+(-6)}{2}, \frac{0+11}{2} \right) = \left( -\frac{3}{2}, \frac{11}{2} \right)$$

In each case, we simply substitute the coordinates of each point into the midpoint formula. This has the effect of averaging both  $x$ -coordinates and both  $y$ -coordinates.

**2.1 EXERCISES****PRACTICE**

Plot the following sets of points in the Cartesian plane. See Example 1.

1.  $\{(-3, 2), (5, -1), (0, -2), (3, 0)\}$
2.  $\{(-4, 0), (0, -4), (-3, -3), (3, -3)\}$
3.  $\{(3, 4), (-2, -1), (-1, -3), (-3, 0)\}$
4.  $\{(2, 2), (0, 3), (4, -5), (-1, 3)\}$
5.  $\{(0, 5), (-3, 2), (2, 4), (1, 1)\}$
6.  $\{(8, 3), (-3, 4), (-4, -6), (3, -4)\}$
7.  $\{(-5, -4), (3, 2), (4, 5), (-2, -1), (-4, -4), (1, 1)\}$
8.  $\{(-2, 5), (0, 1), (1, -1), (1, -3), (0, 0), (-1, 2), (0, -2)\}$

Identify the quadrant in which each point lies, if possible. If a point lies on an axis, specify which part (positive or negative) of which axis ( $x$  or  $y$ ). See Example 1.

9.  $(-2, -4)$
10.  $(0, -12)$
11.  $(4, -7)$
12.  $(-2, 0)$
13.  $(9, 0)$
14.  $(3, 26)$
15.  $(-4, -7)$
16.  $(0, 1)$
17.  $(17, -2)$
18.  $(-\sqrt{2}, 4)$
19.  $(-1, 1)$
20.  $(-4, 0)$
21.  $(3, -9)$
22.  $(0, 0)$
23.  $(4, 3)$
24.  $(-3, -11)$
25.  $(0, -97)$
26.  $\left(\frac{1}{3}, 0\right)$

For each of the following equations, determine the value of the missing entries in the accompanying table of ordered pairs. Then plot the ordered pairs and sketch your guess of the complete graph of the equation. See Example 2.

27.  $6x - 4y = 12$

| $x$ | $y$ |
|-----|-----|
| 0   | ?   |
| ?   | 0   |
| 3   | ?   |
| ?   | 3   |

28.  $y = x^2 + 2x + 1$

| $x$ | $y$ |
|-----|-----|
| ?   | 0   |
| 1   | ?   |
| ?   | 1   |
| 2   | ?   |
| -3  | ?   |

29.  $x = y^2$

| $x$ | $y$         |
|-----|-------------|
| 0   | ?           |
| 1   | ?           |
| 4   | ?           |
| 9   | ?           |
| ?   | $-\sqrt{2}$ |

30.  $5x - 2 = -y$

| $x$ | $y$ |
|-----|-----|
| ?   | 0   |
| 0   | ?   |
| 1   | ?   |
| ?   | 7   |
| -2  | ?   |

31.  $x^2 + y^2 = 9$

| $x$ | $y$ |
|-----|-----|
| 0   | ?   |
| ?   | 0   |
| -1  | ?   |
| 1   | ?   |
| ?   | 2   |

32.  $y = -x^2$

| $x$ | $y$ |
|-----|-----|
| 0   | ?   |
| -1  | ?   |
| 1   | ?   |
| -2  | ?   |
| 2   | ?   |

Determine **a.** the distance between the following pairs of points, and **b.** the midpoint of the line segment joining each pair of points. See Examples 3 and 4.

33.  $(-2, 3)$  and  $(-5, -2)$

34.  $(-1, -2)$  and  $(2, 2)$

35.  $(0, 7)$  and  $(3, 0)$

36.  $\left(-\frac{1}{2}, 5\right)$  and  $\left(\frac{9}{2}, -7\right)$

37.  $(-2, 0)$  and  $(0, -2)$

38.  $(5, 6)$  and  $(-3, -2)$

39.  $(13, -14)$  and  $(-7, -2)$

40.  $(-8, 3)$  and  $(2, 11)$

41.  $(-3, -3)$  and  $(5, -9)$

42.  $(7, -7)$  and  $(-7, -6)$

43.  $(5, -4)$  and  $(-1, 5)$

44.  $(4, 6)$  and  $(2, -7)$

45.  $(8, 8)$  and  $(-2, -2)$

46.  $\left(3, \frac{26}{5}\right)$  and  $\left(9, -\frac{14}{5}\right)$

47. Given  $(10, 4)$  and  $(x, -2)$ , find  $x$  such that the distance between these two points is 10.

48. Given  $(1, y)$  and  $(13, -3)$ , find  $y$  such that the distance between these two points is 15.

49. Given  $(x, 3)$  and  $(-6, y)$ , find  $x$  and  $y$  such that the midpoint between these two points is  $(2, 2)$ .

Find the perimeter of the triangle whose vertices are the specified points in the plane.

50.  $(-2, 3)$ ,  $(-2, 1)$ , and  $(-5, -2)$

51.  $(-1, -2)$ ,  $(2, -2)$ , and  $(2, 2)$

52.  $(6, -1)$ ,  $(-6, 4)$ , and  $(9, 3)$

53.  $(3, -4)$ ,  $(-7, 0)$ , and  $(-2, -5)$

54.  $(-3, 7)$ ,  $(5, 1)$ , and  $(-3, -14)$

55.  $(-12, -3)$ ,  $(-7, 9)$ , and  $(9, -3)$

### APPLICATIONS

56. Two college friends are taking a weekend road trip. Friday they leave home and drive 87 miles north for a night of dinner and dancing in the city. The next morning they drive 116 miles east to spend a day at the beach. If they drive straight home from the beach the next day, how far do they have to travel on Sunday?

57. Your backpacker's guide contains a grid map of Paris, with each unit on the grid representing 0.25 kilometers. If the Eiffel Tower is located at  $(-8, -1)$  and the Arc de Triomphe is located at  $(-8, 4)$ , what is the direct distance (not walking distance, which would have to account for bridges and roadways) between the two monuments in kilometers?
58. Your hotel, located at  $(-1, -2)$  on the map from Exercise 57, is advertised as exactly halfway between the Eiffel Tower and Notre Dame. What are the grid coordinates of Notre Dame on your map? Find the direct distance from the Eiffel Tower to Notre Dame, rounded to the nearest hundredth of a kilometer.
59. The navigator of a submarine plots the position of the submarine and surrounding objects using a rectangular coordinate system, where each block is one square meter.
- If his submarine is located at  $(50, 231)$  and the mobile base to which he is heading is located at  $(83, 478)$ , how far is he from the mobile base?
  - Suppose there is another submarine located halfway between the first submarine and the mobile base. What is the position of the second sub?
60. At the entrance to Paradise Island Theme Park you are given a map of the park that is in the form of a grid, with the park entrance located at  $(-5, -5)$ . After walking past three rides and the restrooms, you arrive at the Tsunami Water Ride, which is located at  $(-3, -1)$  on the grid. If you have traveled halfway along a straight line to your favorite ride, Thundering Tower, where on the grid is your favorite ride located? How far is Thundering Tower from the park entrance on the map?

 **WRITING & THINKING**

61. Use the distance formula to prove that the triangle with vertices at the points  $(1, 1)$ ,  $(-2, -5)$ , and  $(3, 0)$  is a right triangle. Then determine the area of the triangle.
62. Use the distance formula to prove that the triangle with vertices at the points  $(-2, 2)$ ,  $(1, -2)$ , and  $(2, 5)$  is isosceles. Then determine the area of the triangle. (**Hint:** Make use of the midpoint formula.)
63. Use the distance formula to prove that the triangle with vertices at the points  $(5, 1)$ ,  $(-3, 7)$ , and  $(8, 5)$  is a right triangle. Then determine the area of the triangle.
64. Use the distance formula to prove that the triangle with vertices at the points  $(1, 2)$ ,  $(-2, 0)$ , and  $(3, 5)$  is isosceles. Then determine the area of the triangle. (**Hint:** Make use of the midpoint formula.)
65. Use the distance formula to prove that the triangle with vertices at the points  $(2, 2)$ ,  $(6, 3)$ , and  $(4, 11)$  is a right triangle. Then determine the area of the triangle.
66. Use the distance formula to prove that the triangle with vertices at the points  $(2, -1)$ ,  $(4, 3)$ , and  $(-2, -3)$  is isosceles. Then determine the area of the triangle. (**Hint:** Make use of the midpoint formula.)

67. Use the distance formula to prove that the polygon with vertices at the points  $(-2, -1)$ ,  $(6, 5)$ ,  $(-2, 5)$ , and  $(6, -1)$  is a rectangle. Then determine the area of the rectangle. (**Hint:** It may help to plot the points before you begin.)
68. Plot the points  $(-3, 3)$ ,  $(-5, -2)$ ,  $(3, -2)$ , and  $(1, 3)$  to demonstrate they are the vertices of a trapezoid. Then determine the area of the trapezoid.

 TECHNOLOGY

Determine appropriate settings on a graphing utility so that each of the given points will lie within the viewing window. Answers will vary slightly.

69.  $\{(-4, 1), (2, 8), (5, 7)\}$
70.  $\{(12, 3), (5, -11), (-9, 6)\}$
71.  $\{(3, 2), (-2, 4), (5, -3)\}$
72.  $\{(30, 55), (40, 25), (-80, -10)\}$
73.  $\{(3.75, -8.5), (-5.25, 6.0), (7.5, -2.25)\}$
74.  $\{(63, 99), (-87, 34), (45, -22)\}$

## 2.2 EXERCISES

### PRACTICE

Find the standard form of the equation for the circle. See Examples 1 and 2.

1. Center  $(-4, -3)$ ; radius 5
2. Center at origin; radius 3
3. Center  $(7, -9)$ ; radius 3
4. Center  $(-2, 2)$ ; radius 2
5. Center  $(0, 0)$ ; radius  $\sqrt{6}$
6. Center  $(6, 3)$ ; radius 8
7. Center  $(\sqrt{5}, \sqrt{3})$ ; radius 4
8. Center  $(\frac{5}{3}, \frac{8}{5})$ ; radius  $\sqrt{8}$
9. Center  $(7, 2)$ ; passes through  $(7, 0)$
10. Center  $(3, 3)$ ; passes through  $(1, 3)$
11. Center  $(-3, 8)$ ; passes through  $(-4, 9)$
12. Center  $(0, 0)$ ; passes through  $(2, 10)$
13. Center  $(4, 8)$ ; passes through  $(1, 9)$
14. Center  $(12, -4)$ ; passes through  $(-9, 5)$
15. Center at the origin; passes through  $(6, -7)$
16. Center  $(13, -2)$ ; passes through  $(8, -3)$
17. Endpoints of a diameter are  $(-8, 6)$  and  $(1, 11)$
18. Endpoints of a diameter are  $(5, 3)$  and  $(8, -3)$
19. Endpoints of a diameter are  $(-7, -4)$  and  $(-5, 7)$
20. Endpoints of a diameter are  $(2, 3)$  and  $(7, 4)$
21. Endpoints of a diameter are  $(0, 0)$  and  $(-13, -14)$
22. Endpoints of a diameter are  $(4, 10)$  and  $(0, 3)$
23. Endpoints of a diameter are  $(0, 6)$  and  $(8, 0)$
24. Endpoints of a diameter are  $(6, 9)$  and  $(4, 9)$

Find the standard form of the equation for the circle. See Example 3.

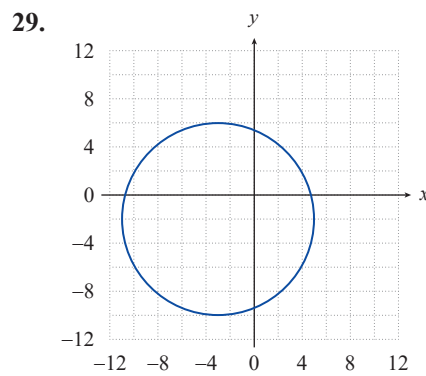
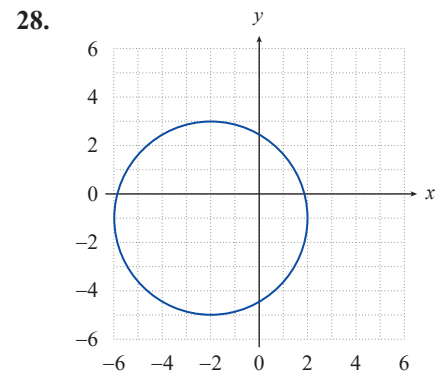
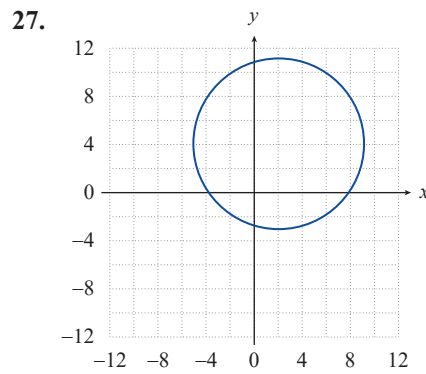
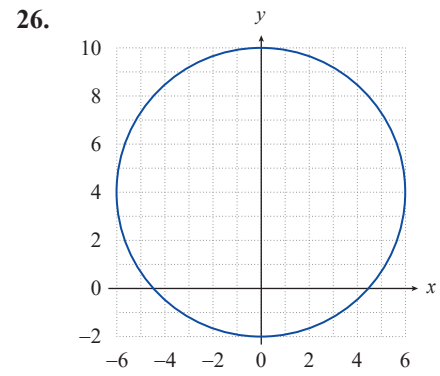
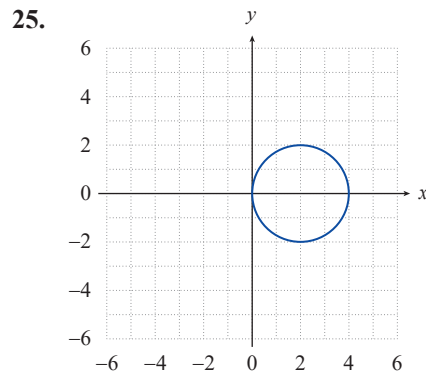

Sketch a graph of the equation and find the center and radius of each circle. See Examples 4 and 5.

30.  $x^2 + y^2 = 25$

31.  $x^2 + y^2 = 36$

32.  $x^2 + (y - 3)^2 = 16$

33.  $x^2 + (y - 8)^2 = 9$

34.  $(x + 2)^2 + y^2 = 49$

35.  $(x - 8)^2 + y^2 = 8$

36.  $(x - 9)^2 + (y - 4)^2 = 49$

37.  $(x + 5)^2 + (y + 4)^2 = 4$

38.  $(x+2)^2 + (y-7)^2 = 64$

40.  $x^2 + y^2 - 2x + 10y + 1 = 0$

42.  $x^2 + y^2 + 6x + 5 = 0$

44.  $x^2 + y^2 - x - y = 2$

46.  $(x-5)^2 + y^2 = 225$

48.  $(x-3)^2 + (y+2)^2 = 81$

50.  $(x+2)^2 + (y-1)^2 = 61$

52.  $x^2 + (y+2)^2 = 49$

54.  $x^2 + y^2 + 8x = 9$

39.  $(x-5)^2 + (y+5)^2 = 5$

41.  $x^2 + y^2 - 4x + 4y - 8 = 0$

43.  $x^2 + y^2 + 10y + 9 = 0$

45.  $x^2 + y^2 + 6y - 2x = -2$

47.  $4x^2 + 4y^2 = 256$

49.  $x^2 + y^2 - 6x + 4y - 3 = 0$

51.  $(x-1)^2 + y^2 = 9$

53.  $x^2 + y^2 - 4x + 8y - 16 = 0$

55.  $4x^2 + 4y^2 - 24x + 24y = 28$

b.  $2x - 2 = 3$

$$x = \frac{5}{2}$$

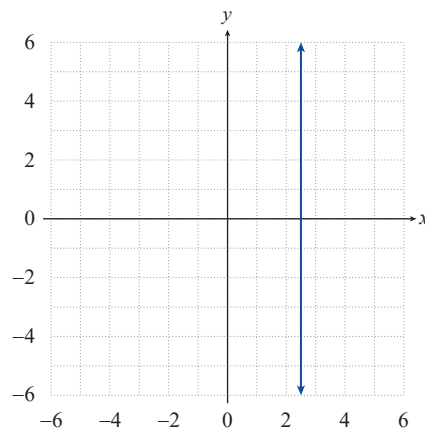

FIGURE 9

Upon simplifying, note that this equation also represents a vertical line, this time passing through  $\frac{5}{2}$  on the  $x$ -axis.

c.  $3x + 2(x + 7) - 2y = 5x$

$$y = 7$$

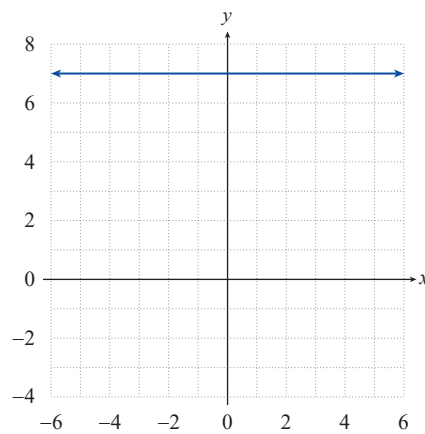

FIGURE 10

We encountered this equation in Example 1b and have already written it in standard form as shown.

The graph of this equation is the horizontal line consisting of all those ordered pairs whose  $y$ -coordinate is 7.

## 2.3 EXERCISES

### 💡 PRACTICE

Determine if the following equations are linear. See Example 1.

1.  $3x + 2(x - 4y) = 2x - y$

2.  $9x + 4(y - x) = 3$

3.  $9x^2 - (x + 1)^2 = y - 3$

4.  $3x + xy = 2y$

5.  $8 - 4xy = x - 2y$

6.  $\frac{x - y}{2} + \frac{7y}{3} = 5$

7.  $\frac{6}{x} - \frac{5}{y} = 2$

9.  $2y - (x + y) = y + 1$

11.  $x^2 - (x - 1)^2 = y$

13.  $x(y + 1) = 16 - y(1 - x)$

15.  $x - 2x^2 + 3 = \frac{x - 7}{2}$

17.  $13x - 17y = y(7 - 2x)$

19.  $x - 1 = \frac{2y}{x} - x$

21.  $x - x(1 + x) = y - 3x$

23.  $\frac{2y - 5}{14} = \frac{x - 3}{9}$

8.  $3x - 3(x - 2y) = y + 1$

10.  $(3 - y)^2 - y^2 = x + 2$

12.  $(x + y)^2 - (x - y)^2 = 1$

14.  $\frac{x - 3}{2} = \frac{4 + y}{5}$

16.  $x - 3 = \frac{4x + 17}{5}$

18.  $y^2 - 3y = (1 + y)^2 - 2x$

20.  $3x - 4 = 89(x - y) - y$

22.  $x^2 - 2x = 3 - x^2 + y$

24.  $16x = y(4 + (x - 3)) - xy$

Find the  $x$ - and  $y$ -intercepts of the given equations, if possible, and then sketch their graphs. See Examples 2 and 3.

25.  $4x - 3y = 12$

26.  $y - 3x = 9$

27.  $5 - y = 10x$

28.  $y - 2x = y - 4$

29.  $3y = 9$

30.  $2x - (x + y) = x + 1$

31.  $x + 2y = 7$

32.  $y - x = x - y$

33.  $y = -x$

34.  $2x - 3 = 1 - 4y$

35.  $3y + 7x = 7(3 + x)$

36.  $4 - 2y = -2 - 6x$

37.  $x + y = 1 + 2y$

38.  $3y + x = 2x + 3y + 4$

39.  $3(x + y) + 1 = x - 5$

Match each equation to the correct graph.

40.  $y = 2x + 3$

41.  $2x + 3y = 4$

42.  $2x - 1 = 5$

43.  $y + 3 - x = 3$

44.  $4y + 3 = 11$

45.  $5y - x - 1 = 4y + 3x + 5$

a.

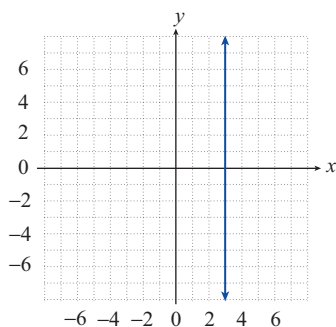

b.

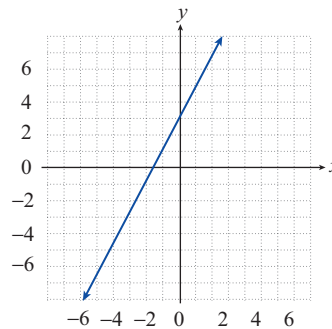

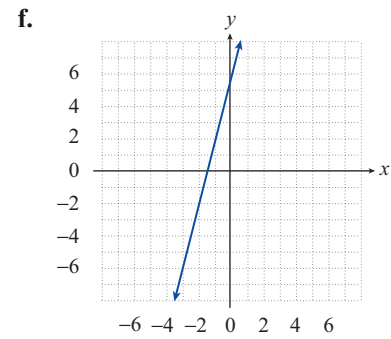
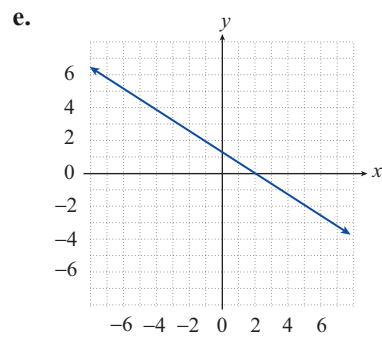
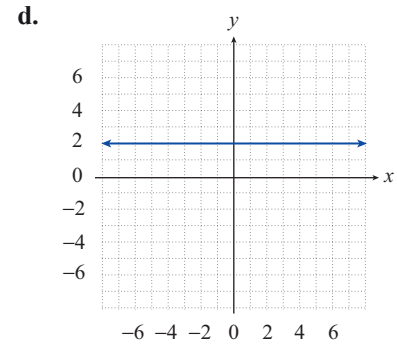
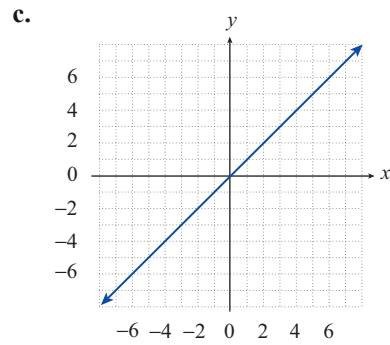

Solve each equation for the specified variable.

46. Standard form of a line:  $ax + by = c$ ; solve for  $y$

47. Perimeter of a triangle:  $P = a + b + c$ ; solve for  $a$

48. Surface area of a rectangular solid:  $S = 2lw + 2wh + 2lh$ ; solve for  $w$

### APPLICATIONS

49. In your history class, you were told that the current population of Jamaica is approximately 24,000 more than 9 times the population of the Bahamas. Using  $j$  to represent the population of Jamaica and  $b$  to represent the population of the Bahamas, write this in the form of an equation. Then solve your equation for  $b$  to find an equation representing the population of the Bahamas. Are these equations linear?
50. The lowest point in the ocean, the bottom of the Mariana Trench, is about 1100 feet deeper than 26 times the depth of the lowest point on land, the Dead Sea. Find an equation to express the depth of the Mariana Trench,  $m$ , in terms of the depth of the Dead Sea,  $d$ . Then solve your equation for  $d$  to find the depth of the Dead Sea in terms of the depth of the Mariana Trench. Are these equations linear?

## 2.4 EXERCISES

### PRACTICE

Determine the slope of the line passing through the specified points. See Example 1.

1.  $(0, -3)$  and  $(-2, 5)$
2.  $(-3, 2)$  and  $(7, -10)$
3.  $(4, 5)$  and  $(-1, 5)$
4.  $(3, -1)$  and  $(-7, -1)$
5.  $(3, -5)$  and  $(3, 2)$
6.  $(0, 0)$  and  $(-2, 5)$
7.  $(-2, 1)$  and  $(-5, -1)$
8.  $\left(\frac{1}{2}, -7\right)$  and  $\left(\frac{3}{4}, -5\right)$
9.  $\left(10, \frac{1}{5}\right)$  and  $\left(4, -\frac{4}{5}\right)$
10.  $(-2, 4)$  and  $(6, 9)$
11.  $(0, -21)$  and  $(-3, 0)$
12.  $(-3, -5)$  and  $(-2, 8)$
13.  $\left(\frac{1}{3}, 9\right)$  and  $(2, 4)$
14.  $(29, -17)$  and  $(31, -29)$
15.  $(7, 4)$  and  $(-6, 13)$

Determine the slopes of the lines defined by the following equations. See Example 2.

16.  $8x - 2y = 11$
17.  $2x + 8y = 11$
18.  $12x - 4y = -9$
19.  $4y = 13$
20.  $\frac{x-y}{3} + 2 = 4$
21.  $7x = 2$
22.  $3y - 2 = \frac{x}{5}$
23.  $3 - y = 2(5 - x)$
24.  $3(2y - 1) = 5(2 - x)$
25.  $\frac{x+2}{3} + 2(1-y) = -2x$
26.  $2y - 7x = 4y + 5x$
27.  $x - 7 = \frac{2y-1}{-5}$

Use the slope-intercept form to graph the equations. See Example 3.

28.  $6x - 2y = 4$
29.  $3y + 2x - 9 = 0$
30.  $5y - 15 = 0$
31.  $x + 4y = 20$
32.  $\frac{x-y}{2} = -1$
33.  $3x + 7y = 8y - x$
34.  $-4x - 4y = 8$
35.  $-5x + 3y + 16 = 0$
36.  $3x = 3y - 21$

Find the equation, in slope-intercept form, of the line with the given  $y$ -intercept and slope. See Example 4.

37.  $y$ -intercept  $(0, -3)$ ; slope of  $\frac{3}{4}$       38.  $y$ -intercept  $(0, 5)$ ; slope of  $-3$

39.  $y$ -intercept  $(0, -7)$ ; slope of  $-\frac{5}{2}$       40.  $y$ -intercept  $(0, 6)$ ; slope of  $4$

41.  $y$ -intercept  $(0, -9)$ ; slope of  $-5$       42.  $y$ -intercept  $(0, 2)$ ; slope of  $\frac{1}{2}$

Find the equation, in standard form, of the line passing through the given point with the given slope.

43. point  $(-1, -3)$ ; slope of  $\frac{3}{2}$       44. point  $(6, 0)$ ; slope of  $\frac{5}{4}$

45. point  $(-3, 5)$ ; slope of  $0$       46. point  $(-2, -13)$ ; undefined slope

47. point  $(3, -1)$ ; slope of  $10$       48. point  $(-1, 3)$ ; slope of  $-\frac{2}{7}$

49. point  $(5, 11)$ ; slope of  $-3$       50. point  $(5, -9)$ ; slope of  $-\frac{1}{2}$

Find the equation, in standard form, of the line passing through the specified points.

51.  $(-1, 3)$  and  $(2, -1)$       52.  $(1, 3)$  and  $(-2, 3)$

53.  $(2, -2)$  and  $(2, 17)$       54.  $(-9, 2)$  and  $(1, 5)$

55.  $(3, -1)$  and  $(8, -1)$       56.  $\left(\frac{4}{3}, 1\right)$  and  $\left(\frac{2}{5}, \frac{3}{7}\right)$

57.  $(-2, 8)$  and  $(5, 6)$       58.  $(8, -10)$  and  $(8, 0)$

59.  $(7, 5)$  and  $(-9, 5)$       60.  $(7, 7)$  and  $(9, -8)$

61.  $\left(\frac{2}{3}, \frac{5}{4}\right)$  and  $\left(\frac{3}{5}, \frac{9}{8}\right)$       62.  $(-5, -5)$  and  $(10, -11)$

Match each equation or description to the correct graph.

63.  $-3x - 2y = 17$

65.  $-6y + 9 = \frac{x}{-2}$

67. point  $(-2, 4)$ ; slope  $-2$

64.  $-4y + 10 = -4x$

66. point  $(-9, 7)$ ; slope  $\frac{4}{3}$

68. point  $(0, -5)$ ; slope  $-9$

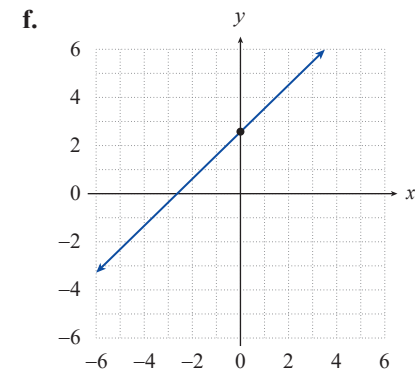
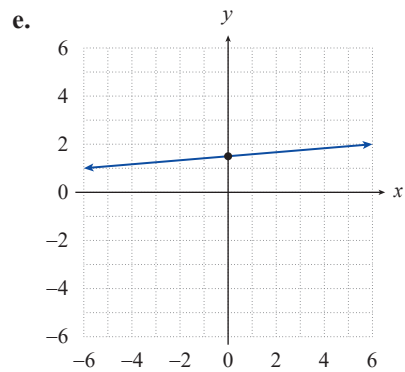
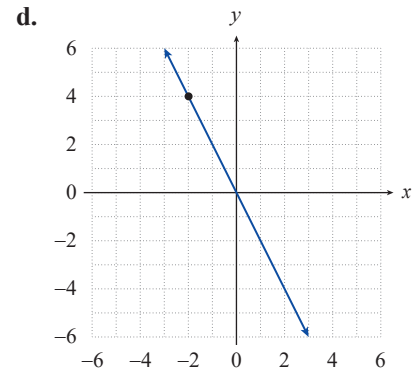
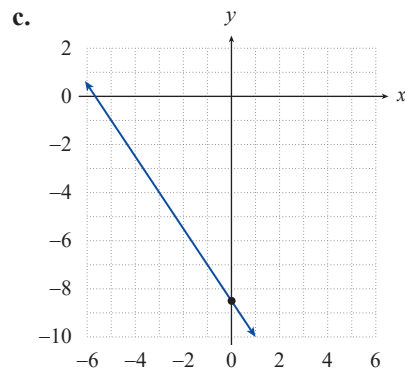
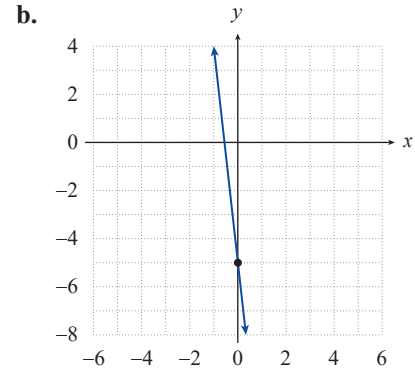
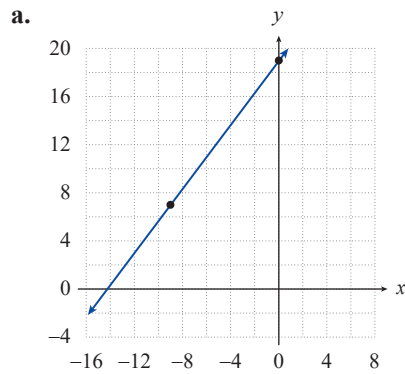

 APPLICATIONS

69. A bottle manufacturer has determined that the total cost ( $C$ ) in dollars of producing  $x$  bottles is  $C = 0.25x + 2100$ .
- What is the cost of producing 500 bottles?
  - What are the fixed costs (costs incurred even when 0 bottles are produced)?
  - What is the increase in cost for each bottle produced?
70. Sales at Glover's Golf Emporium have been increasing linearly for the past couple of years. Last year, sales were \$163,000. This year, sales were \$215,000. If sales continue to increase at this linear rate, predict the sales for next year.
71. Amy owns stock in a company. If the stock had a value of \$2500 in 2018 when she purchased it, what has been the average change in value per year if in 2020 the stock was worth \$3150?
72. For tax and accounting purposes, businesses often have to depreciate equipment values over time. One method of depreciation is the straight-line method. Three years ago Hilde Construction purchased a bulldozer for \$51,500. Using the straight-line method, the bulldozer has now depreciated to a value of \$43,200. If  $V$  equals the value at the end of year  $t$ , write a linear equation expressing the value of the bulldozer over time. How many years from the purchase date will the value equal \$0? Round your answer to two decimal places.

**NOTE**

A pair of lines cannot be both parallel and perpendicular.

Are the lines parallel? No, the slopes are not equal.  
 Are the lines perpendicular? Yes, the slopes are negative reciprocals of each other.  
 Thus, the lines are perpendicular.

- b. One line is in point-slope form, so we can see its slope is 9. We calculate the slope of the other line using the two points given.

$$m = \frac{22 - 4}{2 - 0} = \frac{18}{2} = 9$$

Are the lines parallel? Yes, the slopes are equal.  
 Thus, the lines are parallel. (Note that we didn't need to find the equation of the second line.)

- c. Both lines are in slope-intercept form, so we can read off the slopes:  $\frac{3}{4}$  and  $\frac{4}{3}$ .

Are the lines parallel? No, the slopes are not equal.  
 Are the lines perpendicular? No, the slopes are reciprocals, not *negative* reciprocals.  
 Thus, the lines are neither parallel nor perpendicular.

**2.5 EXERCISES****PRACTICE**

Find the equation, in slope-intercept form, for the line parallel to the given line and passing through the indicated point. See Examples 1 and 2.

- |   |  |
|---|--|
| 1. $y - 4x = 7$ ; $(-1, 5)$                       | 2. $6x + 2y = 19$ ; $(-6, -13)$                  |
| 3. $3x + 2y = 3y - 7$ ; $(3, -2)$                 | 4. $2 - \frac{y - 3x}{3} = 5$ ; $(0, -2)$        |
| 5. $y - 4x = 7 - 4x$ ; $(23, -9)$                 | 6. $2(y - 1) + \frac{x + 3}{5} = -7$ ; $(-5, 0)$ |
| 7. $6y - 4 = -3(1 - 2x)$ ; $(-2, -2)$             | 8. $5 - \frac{7y + 5x}{2} = 1$ ; $(4, 1)$        |
| 9. $2(y - 1) - \frac{7x + 1}{3} = -3$ ; $(1, 10)$ | 10. $8y - 6 = -3(4 - x)$ ; $(11, -5)$            |

Each set of four ordered pairs defines the vertices, in counterclockwise order, of a quadrilateral. Determine if the quadrilateral is a parallelogram. See Example 3.

- |   |   |
|---|---|
| 11. $\{(-2, 2), (-5, -2), (2, -3), (5, 1)\}$  | 12. $\{(-1, 6), (-4, 7), (-2, 3), (1, 1)\}$   |
| 13. $\{(-3, 3), (-2, -2), (3, -1), (2, 4)\}$  | 14. $\{(-2, -3), (-3, -6), (1, -2), (2, 1)\}$ |
| 15. $\{(-6, -2), (-1, 0), (-3, 4), (-8, 2)\}$ | 16. $\{(-3, -2), (3, -3), (5, 2), (-1, 3)\}$  |
| 17. $\{(-1, -1), (5, 1), (3, 5), (-2, 3)\}$   | 18. $\{(0, 1), (6, 0), (7, 4), (1, 6)\}$      |

Determine if the two lines are parallel. See Example 6.

19.  $y = 8x + 7$  and  $y = -8x + 7$
20.  $x - 5y = 2$  and  $5x - y = 2$
21.  $2x - 3y = (x - 1) - (y - x)$  and  $-2y - x = 9$
22.  $3 - (2y + x) = 7(x - y)$  and  $\frac{5y + 1}{4} = 3 + 2x$
23.  $6 = -12(x - y) + y$  and  $13y = -12x + 3$
24.  $\frac{2x - 3y}{3} = \frac{x - 1}{6}$  and  $2y - x = 3$
25.  $\frac{x - y}{2} = \frac{x + y}{3}$  and  $\frac{2x + 3}{5} - 4y = 1 + 2y$
26.  $5 - (4y + 3x) = 5(x - y)$  and  $y + 4 = 5 + 8x$
27.  $7x - 2(x + 3) = 5y - x$  and  $-6x = 1 - 5y$
28.  $\frac{2y + 11x}{3} = x + 1$  and  $7x - 8y = 9x + 7$
29.  $\frac{x - y}{5} = \frac{x + y}{3} - 1$  and  $7 = -2(x - y) + 6y$
30.  $2x + 5y = 14$  and the line passing through the points  $(8, -5)$  and  $(3, -3)$

Find the equation, in slope-intercept form, for the line perpendicular to the given line and passing through the indicated point. See Examples 4 and 5.

31.  $3x + 2y = 3y - 7$ ;  $(3, -2)$
32.  $6y + 2x = 1$ ;  $(-4, -12)$
33.  $-y + 3x = 5 - y$ ;  $(-2, 7)$
34.  $x + y = 5$ ; origin
35.  $x = \frac{1}{4}y - 3$ ;  $(1, -1)$
36.  $2(y + x) - 3(x - y) = -9$ ;  $(2, 5)$
37.  $4x + 8y = 4y - 3$ ;  $(-2, 1)$
38.  $\frac{3x - y}{4} = \frac{4x - 5}{2}$ ;  $(8, 5)$
39.  $4(y + x) - 8(x - y) = -1$ ;  $(6, 10)$
40.  $\frac{3x + 4}{3} - 3y = 1 - 4y$ ;  $(2, -8)$

Determine if the two lines are perpendicular. See Example 6.

41.  $x - 5y = 2$  and  $5x - y = 2$
42.  $y = 5x + 4$  and  $y = -\frac{1}{5}x - 9$
43.  $3x + y = 2$  and  $x + 3y = 2$
44.  $\frac{3x - y}{3} = x + 2$  and  $x = 9$
45.  $5x - 6(x + 1) = 2y - x$  and  $2y - (x + y) = 4y + x$

46.  $-6y + 3x = 7$  and  $8x - 3(x+1) = 3y - x$

47.  $-x = -\frac{2}{5}y + 2$  and  $5y = 2x$

48.  $\frac{7x-5y}{4} = x+2$  and  $-3y-3x = 2x+4$

49.  $3(4-x) = 6y+3$  and  $-3y-2x = 3-8x$

50.  $\frac{x-1}{2} + \frac{3y+2}{3} = -9$  and  $3y-5x = x+5$

51.  $1 - \frac{2y-5x}{2} = 7x+4$  and  $9x-2y = 11$

52.  $y - \frac{2}{3} = 4\left(x + \frac{7}{11}\right)$  and the line passing through the points  $(-2, 4)$  and  $(7, -14)$

Each set of four ordered pairs defines the vertices, in counterclockwise order, of a quadrilateral. Use the ideas in this section to determine if the quadrilateral is a rectangle.

53.  $\{(-2, 2), (-5, -2), (2, -3), (5, 1)\}$  54.  $\{(2, -1), (-2, 1), (-3, -1), (1, -3)\}$

55.  $\{(1, 2), (3, -3), (9, -1), (7, 4)\}$  56.  $\{(5, -7), (1, -13), (28, -31), (32, -25)\}$

57.  $\{(-5, -1), (0, -6), (5, -1), (0, 4)\}$  58.  $\{(-3, -3), (3, -2), (1, 2), (-5, 1)\}$

### 🔑 APPLICATIONS

59. A construction company is building a new suspension bridge that has support cables attached to a center tower at various heights. One cable is attached at a height of 30 feet and connects to the roadbed 50 feet from the base of the tower. If the support cables should run parallel to each other, how far from the base should the company attach a cable whose other end is connected to the tower at a height of 25 feet?

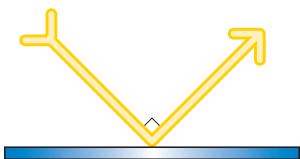
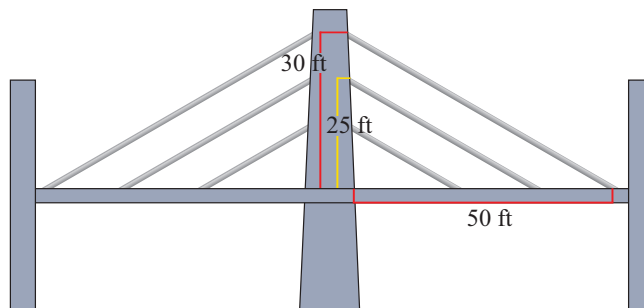

60. A light beam hits a mirror and is reflected off the mirror at a right angle. If the line formed by the original beam of light can be described by an equation of the form  $y = -3.2x + b$  (for some constant  $b$ ), write the form of an equation that describes the line of the reflected beam (use an arbitrary constant  $c$  in your answer).

## 2.6 EXERCISES

### PRACTICE

Solve the following linear inequalities by graphing their solution sets. See Example 1.

- |                        |                                   |                           |
|------------------------|-----------------------------------|---------------------------|
| 1. $x - 3y < 6$        | 2. $y < 2x - 1$                   | 3. $x > \frac{3}{4}y$     |
| 4. $x - 3y \geq 6$     | 5. $3x - y \leq 2$                | 6. $\frac{2x - y}{4} > 1$ |
| 7. $y < -2$            | 8. $x + 1 \geq 0$                 | 9. $x + y < 0$            |
| 10. $x + y > 0$        | 11. $-(y - x) > -\frac{5}{2} - y$ | 12. $-2y \leq -x + 4$     |
| 13. $5(y + 1) \geq -x$ | 14. $3x - 7y \geq 7(1 - y) + 2$   | 15. $x - y < 2y + 3$      |

Graph the solution sets that satisfy the following inequalities. See Example 2.

- |  |                                      |
|--|--------------------------------------|
| 16. $y > -3x - 6$ or $y \leq 2x - 7$       | 17. $y \geq -2$ and $y > 1$          |
| 18. $y \geq -2x - 5$ and $y \leq -6x - 9$  | 19. $y \leq 4x + 4$ and $y > 7x + 7$ |
| 20. $x - 3y \geq 6$ and $y > -4$           | 21. $x - 3y \geq 6$ or $y > -4$      |
| 22. $3x - y \leq 2$ and $x + y > 0$        | 23. $x > 1$ and $y > 2$              |
| 24. $x > 1$ or $y > 2$                     | 25. $x + y > -2$ and $x + y < 2$     |
| 26. $y > -2$ and $2y > -3x - 4$            | 27. $3y > x + 2$ or $4y \leq -x - 2$ |
| 28. $y \leq -x$ and $2y + 3x > -4$         | 29. $5x + 6y < -30$ and $x \geq 2$   |
| 30. $6y - 2x > -6$ or $y > 6$              | 31. $x > -3$ or $y \geq 4$           |
| 32. $-2y < -3x - 6$ or $-3y \geq -6x - 18$ | 33. $x < 6$ and $x \geq -5$          |

Graph the solution sets that satisfy the following linear absolute value inequalities. See Example 3.

- |  |  |
|--|--|
| 34. $ x - 3  < 2$                          | 35. $ x - 3  > 2$                      |
| 36. $ 3y - 1  \leq 2$                      | 37. $ 2x - 4  > 2$                     |
| 38. $1 -  y + 3  < -1$                     | 39. $ x + 1  < 2$ and $ y - 3  \leq 1$ |
| 40. $ x - 3  \geq 1$ or $ y - 2  \leq 1$   | 41. $ x - y  < 1$                      |
| 42. $ x + y  \geq 1$                       | 43. $ 4x - 2y - 3  \leq 5$             |
| 44. $ 2x - 3  \geq 1$ or $ 2y + 3  \geq 1$ | 45. $ y - 3x  \leq 2$ and $ y  < 2$    |

Match the following inequalities to the appropriate graph.

46.  $-8y + 5x \geq -8y + 5$

47.  $x < -2$  and  $x \geq -5$

48.  $|-7x - 4y + 23| \leq 16$

49.  $y \leq 3x - 6$  and  $y > 2x - 4$

50.  $|3y - 2x| > 17$  and  $|y + 6| \geq 1$

51.  $4(y + 2) < -x$

52.  $-y < 6x + 3$  or  $4y \geq 3x - 6$

53.  $|7x + 4| \leq 5$  or  $|7y + 4| \leq 5$

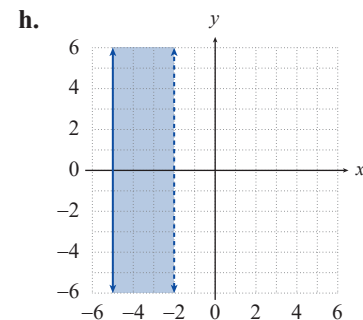
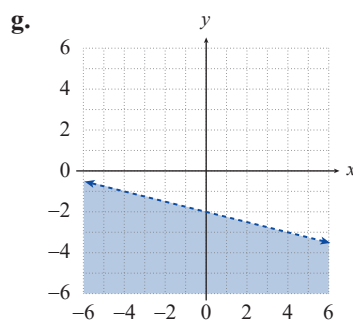
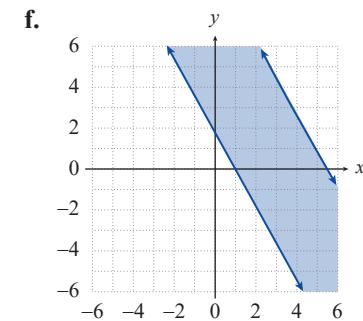
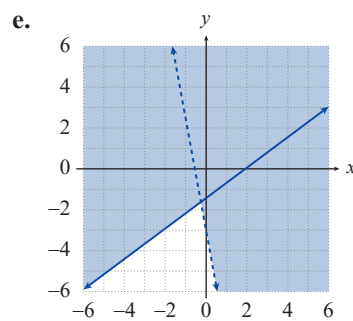
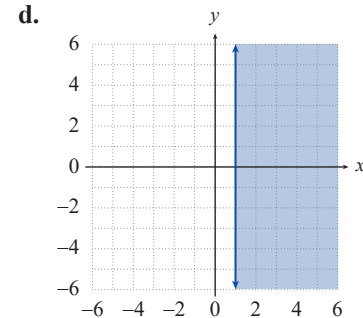
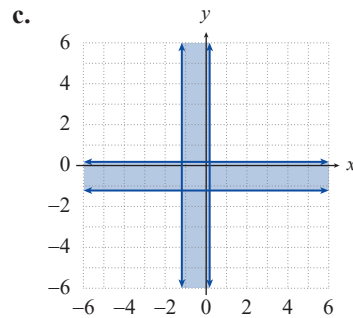
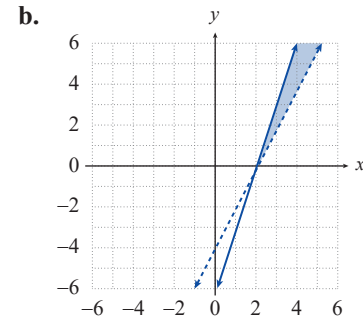
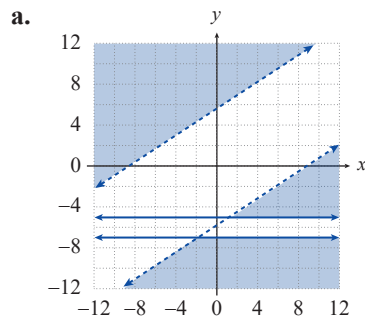

 APPLICATIONS

54. It costs Happy Land Toys \$5.50 in variable costs per doll produced. If total costs must remain less than \$200, write a linear inequality describing the relationship between cost and dolls produced.
55. Trish is having a garden party where she wants to have several arrangements of lilies and orchids for decoration. The lily arrangements cost \$12 each and the orchids cost \$22 each. If Trish wants to spend less than \$150 on flowers, write a linear inequality describing the number of each arrangement she can purchase. Graph the inequality.
56. Rob has 300 feet of fencing he can use to enclose a small rectangular area of his yard for a garden. Assuming Rob may or may not use all the fencing, write a linear inequality describing the possible dimensions of his garden. Graph the inequality.
57. Flowertown Canoes produces two types of canoes. The two-person model costs \$73 to produce and the one-person model costs \$46 to produce. Write a linear inequality describing the number of each canoe the company can produce and keep costs under \$1750. Graph the inequality.

## 3.1 EXERCISES

## PRACTICE

For each of the following relations, determine the domain and range. See Example 1.

1.  $R = \{(-2, 5), (-2, 3), (-2, 0), (-2, -9)\}$

2.  $S = \{(0, 0), (-5, 2), (3, 3), (5, 3)\}$

3.  $A = \{(\pi, 2), (-2\pi, 4), (3, 0), (1, 7)\}$

4.  $B = \{(3, 3), (-4, 3), (3, 8), (3, -2)\}$

5.  $T = \{(x, y) \mid x \in \mathbb{Z} \text{ and } y = 2x\}$

6.  $U = \{(\pi, y) \mid y \in \mathbb{Q}\}$

7.  $C = \{(x, 3x+4) \mid x \in \mathbb{Z}\}$

8.  $D = \{(5x, 3y) \mid x \in \mathbb{Z} \text{ and } y \in \mathbb{Z}\}$

9.  $3x - 4y = 17$

10.  $x + y = 0$

11.  $x = |y|$

12.  $y = x^2$

13.  $y = -1$

14.  $x = 3$

15.  $x = 4x$

16.  $y = 7\pi^2$

17.

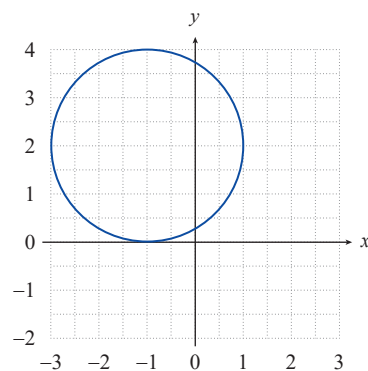

18.

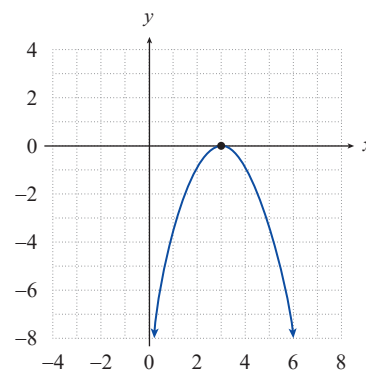

19.

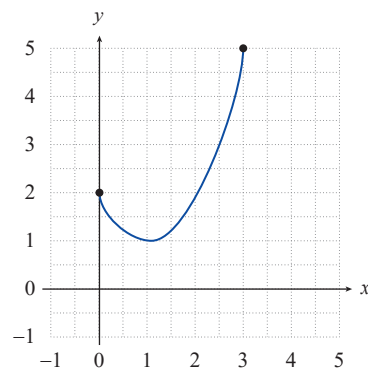

20.

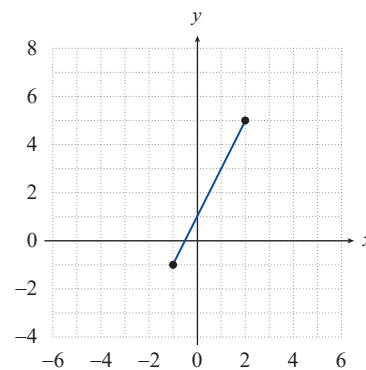

21.

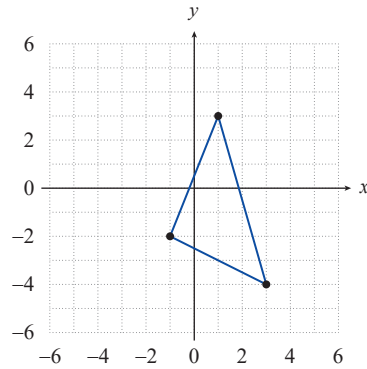

22.

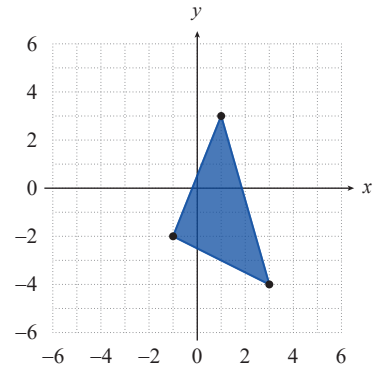

23.  $V = \{(x, y) \mid x \text{ is the brother of } y\}$

24.  $W = \{(x, y) \mid y \text{ is the daughter of } x\}$

Determine which of the following relations is a function. For those that are not functions, identify two ordered pairs with the same first coordinate. See Examples 2 and 3.

25.  $R = \{(-2, 5), (2, 4), (-2, 3), (3, -9)\}$

26.  $S = \{(3, -2), (4, -2)\}$

27.  $T = \{(-1, 2), (1, 1), (2, -1), (-3, 1)\}$

28.  $U = \{(4, 5), (2, -3), (-2, 1), (4, -1)\}$

29.  $V = \{(6, -1), (3, 2), (6, 4), (-1, 5)\}$

30.  $W = \{(2, -3), (-2, 4), (-3, 2), (4, -2)\}$

31.

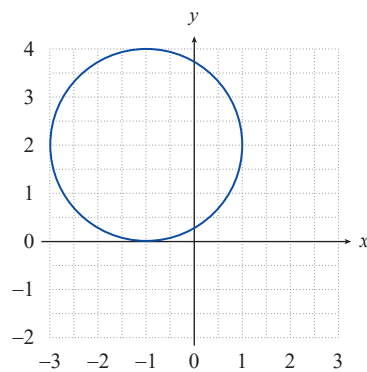

32.

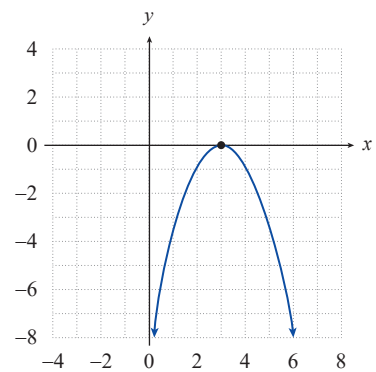

33.

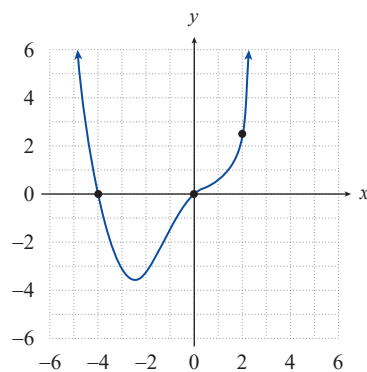

34.

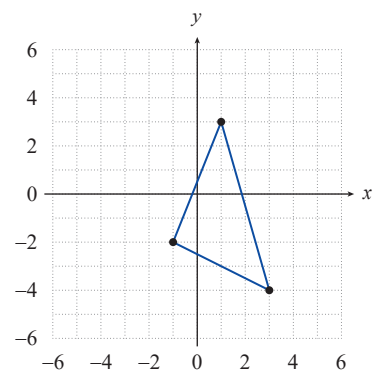

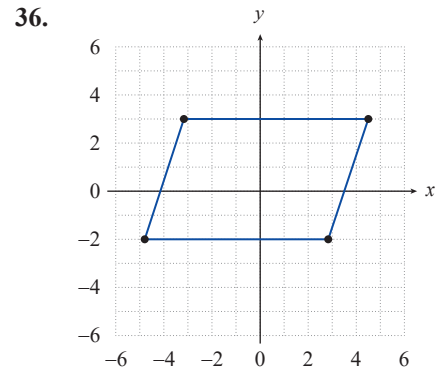
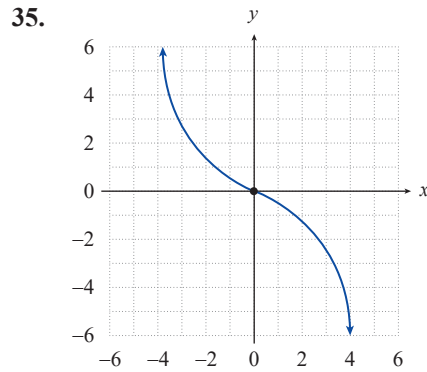

Identify which of the following relations is a function by determining whether there is a unique  $y$ -value related to every  $x$ -value in the relation's domain. For those that are not functions, identify two ordered pairs with the same first coordinate.

37.  $y = \frac{1}{x}$       38.  $x = y^2 - 1$       39.  $x + y^2 = 0$       40.  $y = 2x^2 - 4$   
 41.  $y = \frac{x-1}{x+2}$       42.  $x^2 + y^2 = 1$       43.  $y = |x-2|$       44.  $y = x^3$   
 45.  $y^2 - x^2 = 3$       46.  $y = \sqrt{x} - 4$

Rewrite each of the following relations as a function of  $x$ . Then evaluate the function at  $x = -1$ . See Example 4.

47.  $6x^2 - x + 3y = x + 2y$       48.  $2y - \sqrt[3]{x} = x - (x-1)^2$   
 49.  $\frac{x+3y}{5} = 2$       50.  $x^2 + y = 3 - 4x^2 + 2y$   
 51.  $y - 2x^2 = -2(x + x^2 + 5)$       52.  $\frac{9y+2}{6} = \frac{3x-1}{2}$

Use the graph below of a function  $f$  to answer the following questions. See Example 5.

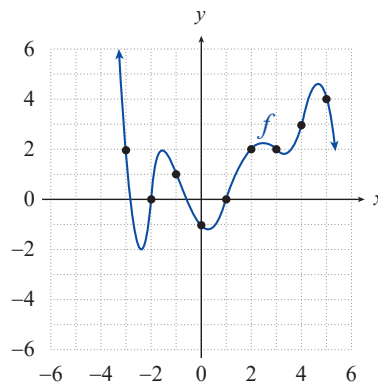

53. What is the value of  $f(-1)$ ?      54. What is the value of  $f(0)$ ?  
 55. What is the value of  $f(4)$ ?

56. For what integer value(s) of  $x$  is  $f(x) = 4$ ?

57. For what integer value(s) of  $x$  is  $f(x) = 2$ ?

58. For what integer value(s) of  $x$  is  $f(x) = 0$ ?

For each of the following functions, determine **a.**  $f(2)$ , **b.**  $f(x-1)$ , **c.**  $f(x+a) - f(x)$ , and **d.**  $f(x^2)$ . See Example 6.

59.  $f(x) = x^2 + 3x$

60.  $f(x) = \sqrt{x}$

61.  $f(x) = 3x + 2$

62.  $f(x) = -x^2 - 7$

63.  $f(x) = 2(5 - 3x)$

64.  $f(x) = 2x^2 + \sqrt[4]{x}$

65.  $f(x) = \sqrt{1-x} - 3$

66.  $f(x) = \frac{-\sqrt{1-x} + 5}{2}$

Determine  $\frac{f(x+h) - f(x)}{h}$  for each of the following functions. See Example 6c.

67.  $f(x) = x^2 - 5x$

68.  $f(x) = x^3 + 2$

69.  $f(x) = \frac{1}{x+2}$

70.  $f(x) = 6x^2 - 7x + 3$

71.  $f(x) = 5x^2$

72.  $f(x) = (x+3)^2$

73.  $f(x) = 2x - 7$

74.  $f(x) = \sqrt{x}$

75.  $f(x) = x^{\frac{1}{2}} - 4$

76.  $f(x) = \frac{3}{x}$

Identify the domain, the codomain, and the range of each of the following functions. See Example 7.

77.  $f: \mathbb{R} \rightarrow \mathbb{R}$  by  $f(x) = 3x$

78.  $g: \mathbb{Z} \rightarrow \mathbb{Z}$  by  $g(x) = 3x$

79.  $f: \mathbb{Z} \rightarrow \mathbb{Z}$  by  $f(x) = x + 5$

80.  $g: [0, \infty) \rightarrow \mathbb{R}$  by  $g(x) = \sqrt{x}$

81.  $h: \mathbb{N} \rightarrow \mathbb{N}$  by  $h(x) = x + 5$

82.  $h: \mathbb{N} \rightarrow \mathbb{R}$  by  $h(x) = \frac{x}{2}$

Determine the implied domain of each of the following functions. See Example 8.

83.  $f(x) = \sqrt{x-1}$

84.  $g(x) = \sqrt[5]{x+3} - 2$

85.  $h(x) = \frac{3x}{x^2 - x - 6}$

86.  $f(x) = (2x+6)^{\frac{1}{2}}$

87.  $g(x) = \sqrt[4]{2x^2 + 3}$

88.  $h(x) = \frac{3x^2 - 6x}{x^2 - 6x + 9}$

89.  $s(x) = \frac{2x}{1-3x}$

90.  $f(x) = (x^2 - 5x + 6)^3$

91.  $c(x) = \frac{x-1}{2-x}$

92.  $g(x) = \frac{5}{\sqrt{3-x^2}}$

93.  $f(x) = \sqrt{x+6} + 1$

94.  $g(x) = -5x^2 - 4x$

95.  $h(x) = \frac{-3(-5+5x)}{x}$

96.  $h(x) = \sqrt{3-x}$

 **WRITING & THINKING**

97. Justify why the following statement is true: All functions are relations, but not all relations are functions.

 **TECHNOLOGY**

Use a graphing utility to evaluate each of the following functions at the specified values of  $x$ .

98.  $f(x) = \frac{7x^{\frac{5}{3}} - 2x^{\frac{1}{3}}}{x^{\frac{1}{2}}}$ ; find  $f(8)$  and  $f(12)$

99.  $g(x) = \sqrt{x^3 - 4x^2 + 2x + 31}$ ; find  $g(2)$  and  $g(3)$

100.  $f(x) = \frac{2x^5 - 9x^3 + 12}{4x^3 - 7x + 6}$ ; find  $f(-3)$  and  $f(2)$

101.  $g(x) = (5x^2 - 7x + 1)^3$ ; find  $g(-19)$  and  $g(12)$

102.  $f(x) = \frac{\sqrt{x^4 + 6x^3 - 4x + 13}}{4x^3 + 2x^2 - 12}$ ; find  $f(-4)$  and  $f(6)$

103.  $g(x) = \frac{(3x^3 - 2x + 9)^4}{(7x^2 - 5x)^2}$ ; find  $g(-5)$  and  $g(4)$

## 3.2 EXERCISES

### 💡 PRACTICE

Graph the following linear functions. See Example 1.

1.  $f(x) = -5x + 2$

2.  $g(x) = \frac{3x-2}{4}$

3.  $h(x) = -x + 2$

4.  $p(x) = -2$

5.  $g(x) = 3 - 2x$

6.  $r(x) = 2 - \frac{x}{5}$

7.  $f(x) = -2(1-x)$

8.  $a(x) = 3\left(1 - \frac{1}{3}x\right) + x$

9.  $f(x) = 2 - 4x$

10.  $g(x) = \frac{2x-8}{4}$

11.  $h(x) = 5x - 10$

12.  $k(x) = 3x - \frac{2+6x}{2}$

13.  $m(x) = \frac{-x+25}{10}$

14.  $q(x) = 1.5x - 1$

15.  $w(x) = (x-2) - (2+x)$

Match the following functions with their graphs.

16.  $f(x) = (8x-14) - (-17+2x)$

17.  $f(x) = 3x - \frac{7+8x}{3}$

18.  $f(x) = \frac{6}{2} - \frac{2}{8}x$

19.  $f(x) = 2\left(2 - \frac{8}{5}x\right) + x$

a.

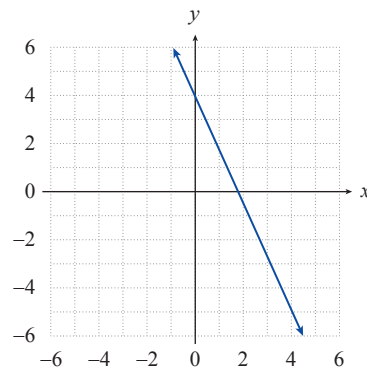

b.

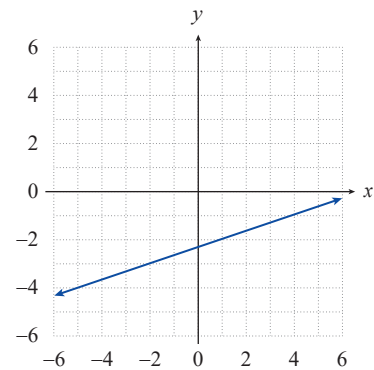

c.

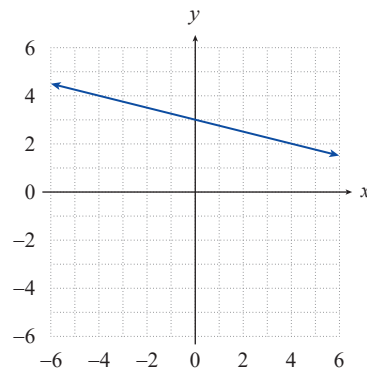

d.

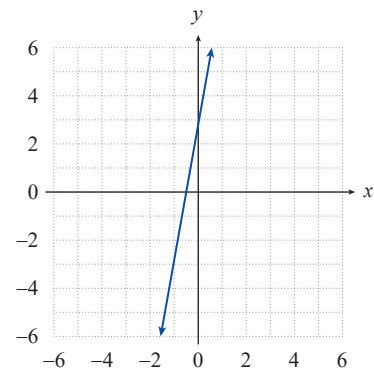

Find a formula for the linear function depicted in each of the following graphs. See Example 2.

20.

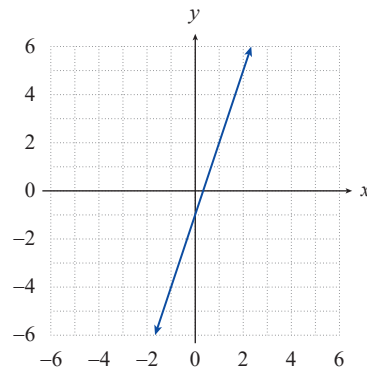

21.

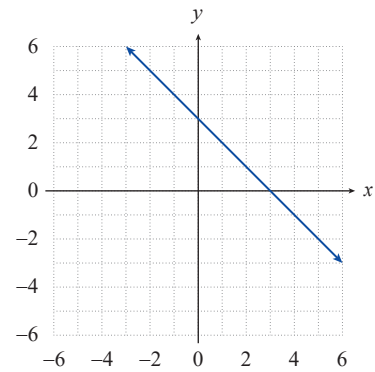

22.

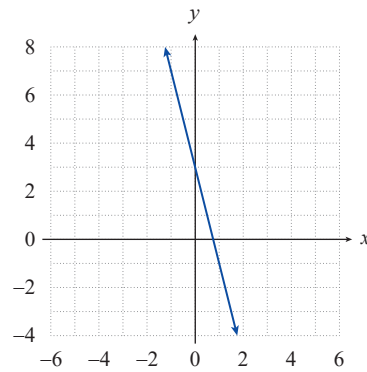

23.

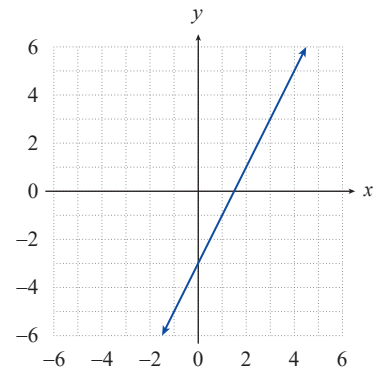

For the given points, **a.** use linear regression to find and graph the line of best fit along with the points, and **b.** find the Pearson correlation coefficient  $r$ . See Examples 3 and 4.

24.  $(0, 3), (1, 5), (2, 7), (3, 8), (5, 9), (6, 9)$

25.  $(1, 10), (2, 8), (3, 7), (4, 6), (5, 5), (6, 5), (7, 4)$

26.  $(1, 9.6), (2, 8.7), (3, 7.7), (4, 6.1), (5, 5.0)$

27.  $(1, 5.2), (2, 6.4), (3, 8.1), (4, 9.2), (5, 10.6)$

28.  $(1, 5), (2, -1), (3, 5), (4, 0), (5, 4)$

29.  $(-2, 2), (-1, 2), (0, -1), (1, -1), (2, 0)$

### 🔑 APPLICATIONS

30. An automobile company is running a new television commercial in five cities with approximately the same population. The following table shows the number of times the commercial is run on TV in each city and the number of car sales (in hundreds).

- Find the linear regression line for the data given in the table.
- Graph the data and the regression line on the same set of axes.
- Find the Pearson correlation coefficient  $r$ .

|  |   |   |    |    |    |
|--|---|---|----|----|----|
| <b>Number of TV Commercials (<math>x</math>)</b> | 4 | 5 | 12 | 16 | 18 |
| <b>Car Sales (in hundreds) (<math>y</math>)</b>  | 3 | 5 | 5  | 8  | 7  |

31. The following table shows the high school grade-point averages (HS-GPA) and the college grade-point averages (C-GPA) after 1 year of college for 10 students.
- Find the linear regression line for the data given in the table.
  - Graph the data and the regression line on the same set of axes.
  - Find the Pearson correlation coefficient  $r$ .

|                                |     |     |     |     |     |     |     |     |     |     |
|--------------------------------|-----|-----|-----|-----|-----|-----|-----|-----|-----|-----|
| <b>HS-GPA (<math>x</math>)</b> | 2.0 | 2.0 | 2.2 | 2.2 | 2.7 | 3.2 | 3.2 | 3.3 | 3.5 | 3.7 |
| <b>C-GPA (<math>y</math>)</b>  | 1.5 | 1.8 | 2.0 | 1.5 | 2.0 | 2.8 | 3.0 | 3.5 | 3.5 | 3.4 |

32. Keisha makes refrigerator magnets and has just started selling them along with other handcrafted items at craft shows. After four shows, she has collected the data below regarding price per magnet versus number of magnets sold.
- Find the linear regression line for the data given in the table.
  - Graph the data and the regression line on the same set of axes.
  - Find the Pearson correlation coefficient  $r$ .

|  |      |      |      |     |
|--|------|------|------|-----|
| <b>Number of Magnets Sold (<math>x</math>)</b> | 1    | 3    | 5    | 8   |
| <b>Price per Magnet (<math>y</math>)</b>       | \$14 | \$11 | \$10 | \$6 |

### WRITING & THINKING

33. The data in a set  $A$  has a Pearson correlation coefficient of 0.98 and the data in a set  $B$  has a Pearson correlation coefficient of  $-0.98$ . Which data set has the strongest correlation? Explain.
34. What does the sign of the Pearson correlation coefficient tell you about the line of best fit?

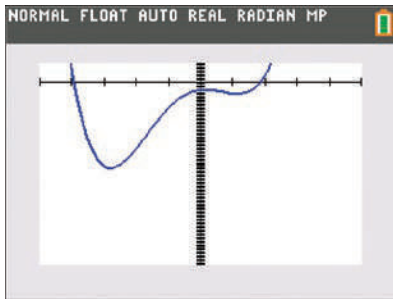

FIGURE 19

### TECHNOLOGY: Finding the Maximum or Minimum of a Function

As we've seen, finding the maximum or minimum possible values of some function  $f(x)$  can be extremely important, and we have a method for doing so when the function is quadratic. But what if we wanted to find the minimum of the function  $f(x) = x^4 + 2x^3 - 7x^2 + 2x - 4$ ? One way is to graph it on a TI-84 Plus, shown in Figure 19 with the following window settings:  $X_{\min} = -5$ ,  $X_{\max} = 5$ ,  $Y_{\min} = -100$ ,  $Y_{\max} = 10$ .

To find the minimum, press **2nd** **trace** to access the **CALCULATE** menu and select **minimum**. (If we were trying to find the maximum, we would select **maximum**.) The screen should now display the graph with **LeftBound?** shown at the bottom. Use the left arrow to move the cursor anywhere to the left of where the minimum appears to be and press **enter**. The screen should now say **RightBound?** at the bottom of the graph. Use the right arrow to move the cursor to the right of where the minimum appears to be and press **enter** again. The text at the bottom of the graph should now read **Guess?** (see Figure 20). Press **enter** a third time and the  $x$ - and  $y$ -values of the minimum will appear at the bottom of the screen (see Figure 21).

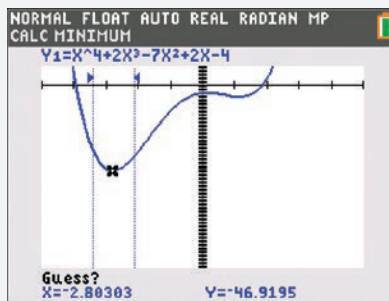

FIGURE 20

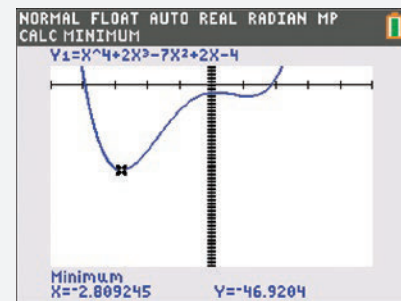

FIGURE 21

So the minimum is approximately  $(-2.809, -46.920)$ .

## 3.3 EXERCISES

### PRACTICE

Graph the following quadratic functions, accurately locating the vertices and  $x$ -intercepts (if any). See Example 1.

- $f(x) = (x-2)^2 + 3$
- $g(x) = -(x+2)^2 - 1$
- $h(x) = x^2 + 6x + 7$
- $F(x) = 3x^2 + 2$
- $G(x) = x^2 - x - 6$
- $p(x) = -2x^2 + 2x + 12$
- $q(x) = 2x^2 + 4x + 3$
- $r(x) = -3x^2 - 1$
- $s(x) = \frac{(x-1)^2}{4}$
- $m(x) = x^2 + 2x + 4$
- $n(x) = (x+2)(2-x)$
- $p(x) = -x^2 + 2x - 5$

13.  $f(x) = 4x^2 - 6$

14.  $k(x) = 2x^2 - 4x$

15.  $q(x) = (x+10)(x-2) + 36$

Match the following functions with their graphs.

16.  $f(x) = -x^2 + 2x$

17.  $f(x) = x^2 + 7x + 6$

18.  $f(x) = \frac{x^2 - 8x + 16}{2}$

19.  $f(x) = (x-5)(x+3) + 16$

a.

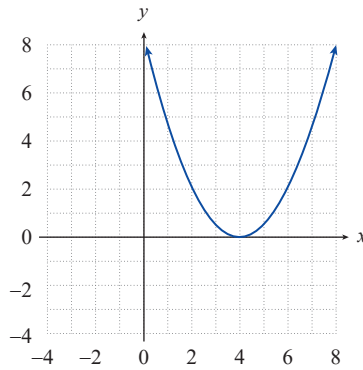

b.

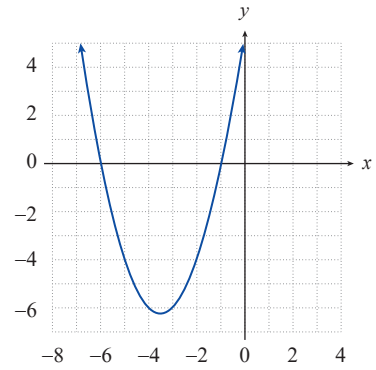

c.

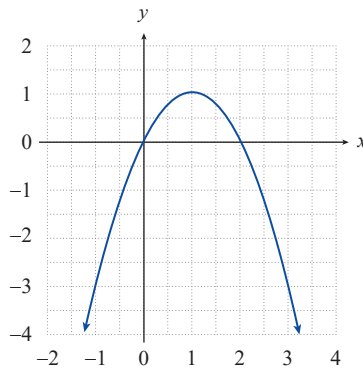

d.

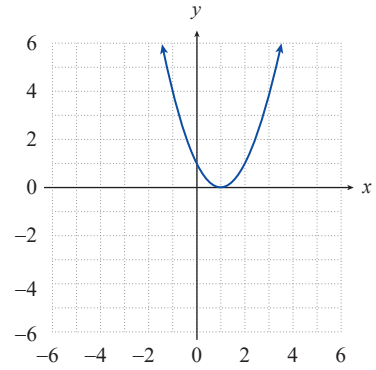

For each of the following parabolic graphs, **a.** find a formula for the corresponding quadratic function, and **b.** use the formula to determine the coordinates of the parabola's vertex. See Example 3.

20.

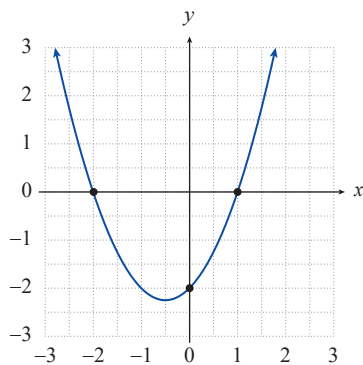

21.

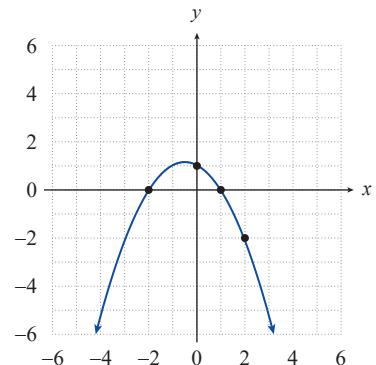

22.

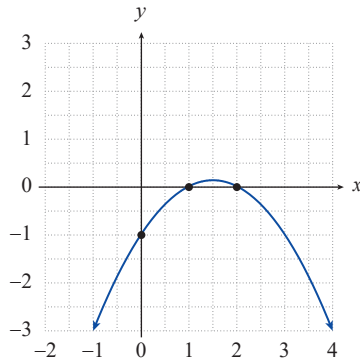

23.

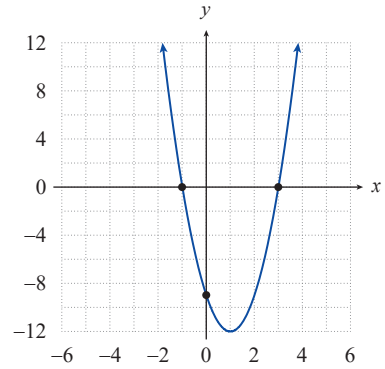

 Given the points graphed in each of the following figures, use quadratic regression to find and graph each quadratic function of best fit. See Example 4.

24.

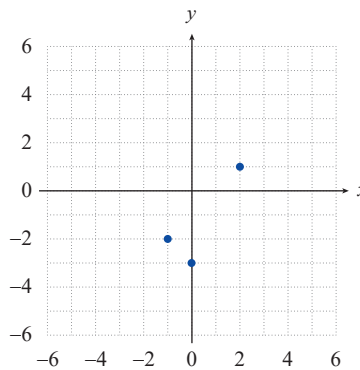

25.

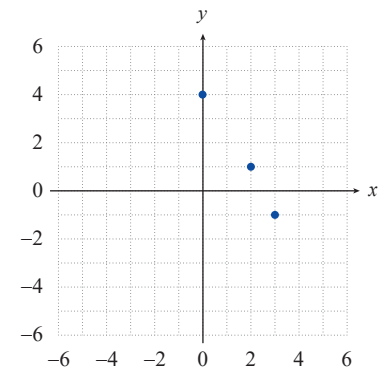

26.

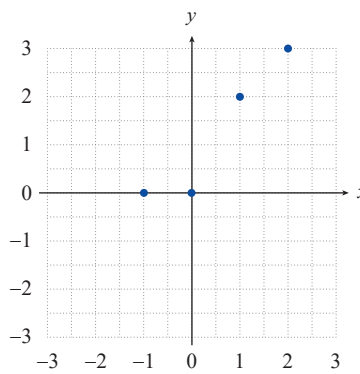

27.

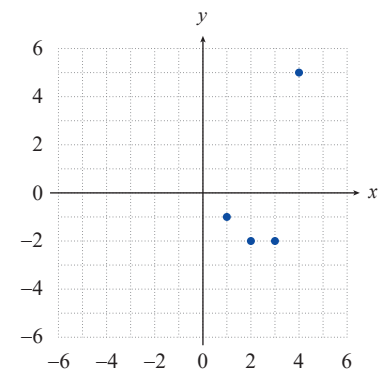

Given the points graphed in each of the following figures, **a.** find the quadratic function that best fits the points, and **b.** use your result to determine the coordinates of the vertex of the best-fitting parabola. See Example 5.

28.

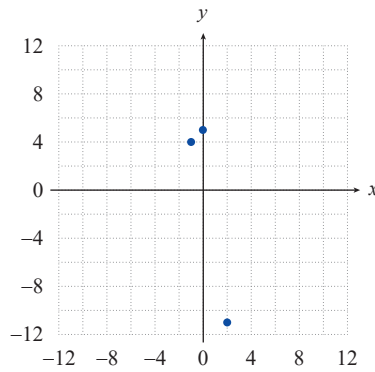

29.

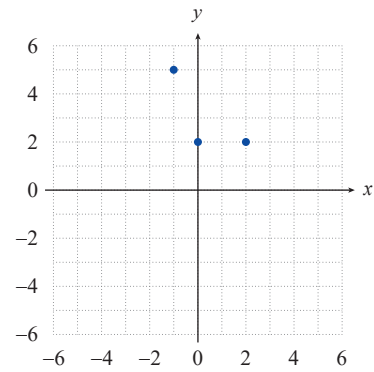

30.

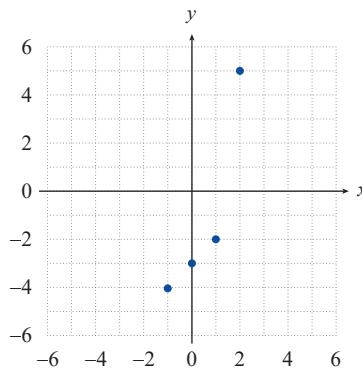

31.

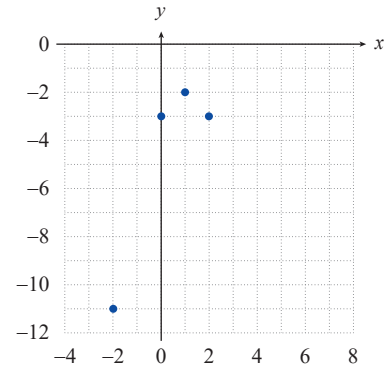

**APPLICATIONS**

32. Cindy wants to construct three rectangular dog-training arenas side by side, as shown, using a total of 400 feet of fencing. What should the overall length and width be in order to maximize the area of the three combined arenas? (**Hint:** Let  $x$  represent the width, as shown, and find an expression for the overall length in terms of  $x$ .)

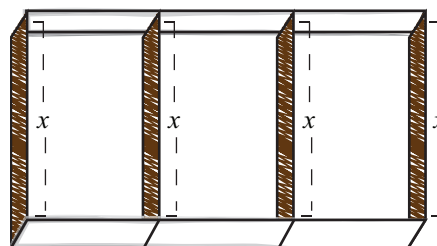

33. Among all the pairs of numbers with a sum of 10, find the pair whose product is maximum.

34. Among all rectangles that have a perimeter of 20, find the dimensions of the one whose area is largest.

35. Find the point on the line  $2x + y = 5$  that is closest to the origin. (**Hint:** Instead of trying to minimize the distance between the origin and points on the line, minimize the square of the distance.)

36. Among all the pairs of numbers  $(x, y)$  such that  $2x + y = 20$ , find the pair for which the sum of the squares is minimum.

37. A rancher has a rectangular piece of sheet metal that is 20 inches wide by 10 feet long. He plans to fold the metal to create a narrow three-sided channel and weld two other sheets of metal to the ends to form a watering trough 10 feet long, as shown. How should he fold the metal in order to maximize the volume of the resulting trough?

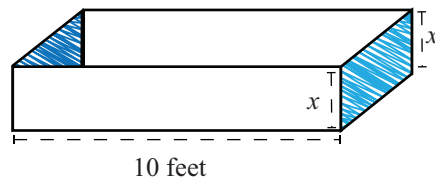

38. Find a pair of numbers whose product is maximum if the pair must have a sum of 16.
39. Search the Seas cruise ship has a conference room onboard that can hold up to 60 people. Companies can reserve the room for groups of 38 or more. If the group contains 38 people, the company pays \$60 per person. The cost per person is reduced by \$1 for each person in excess of 38. Find the size of the group that maximizes the income for the owners of the ship and find this income.
40. The back of George's property is a creek. George would like to enclose a rectangular area, using the creek as one side and fencing for the other three sides, to create a vegetable garden. If he has 300 feet of material, what is the maximum possible area of the garden?
41. Find a pair of numbers whose product is maximum if two times the first number plus the second number is 48.
42. The total revenue for Thompson's Studio Apartments is given by the function
- $$R(x) = 100x - 0.1x^2,$$
- where  $x$  is the number of rooms rented. What number of rooms rented produces the maximum revenue?
43. The total revenue of Tran's Machinery Rental is given by the function
- $$R(x) = 300x - 0.4x^2,$$
- where  $x$  is the number of units rented. What number of units rented produces the maximum revenue?
44. The total cost of producing a type of small car is given by
- $$C(x) = 9000 - 135x + 0.045x^2,$$
- where  $x$  is the number of cars produced. How many cars should be produced to incur minimum cost?
45. The total cost of manufacturing a set of golf clubs is given by
- $$C(x) = 800 - 10x + 0.20x^2,$$
- where  $x$  is the number of sets of golf clubs produced. How many sets of golf clubs should be manufactured to incur minimum cost?
46. The owner of a parking lot is going to enclose a rectangular area with fencing, using an existing fence as one of the sides. The owner has 220 feet of new fencing material (which is much less than the length of the existing fence). What is the maximum possible area that the owner can enclose?

In Exercises 47–49, use the formula  $h(t) = -16t^2 + v_0t + h_0$  for the height at time  $t$  of an object thrown vertically upward with velocity  $v_0$  (in feet per second) from an initial height of  $h_0$  (in feet).

47. Sitting in a tree, 48 feet above ground level, Sue shoots a pebble straight up with a velocity of 64 feet per second. What is the maximum height attained by the pebble?
48. A ball is thrown upward with a velocity of 48 feet per second from the top of a 144-foot building. What is the maximum height of the ball?
49. A rock is thrown upward with a velocity of 80 feet per second from the top of a 64-foot-high cliff. What is the maximum height of the rock?

 Use quadratic regression to answer the following questions. See Example 7.

50. Darlena has started taking photos at amateur dog racing events, later offering the photos for sale to the dog owners by email. The prices she has charged per photo at each of her first three events, and the corresponding number of photos sold and total revenue raised, appear in the following table. Treating revenue as a function of the number of photos sold, a graph of the three data points is also shown. If she uses quadratic regression to fit a curve to the data, what number of photos sold and what price per photo will maximize her revenue?

| Price per Photo | Number of Photos Sold | Revenue |
|-----------------|-----------------------|---------|
| \$28            | 2                     | \$56    |
| \$24            | 4                     | \$96    |
| \$12            | 10                    | \$120   |

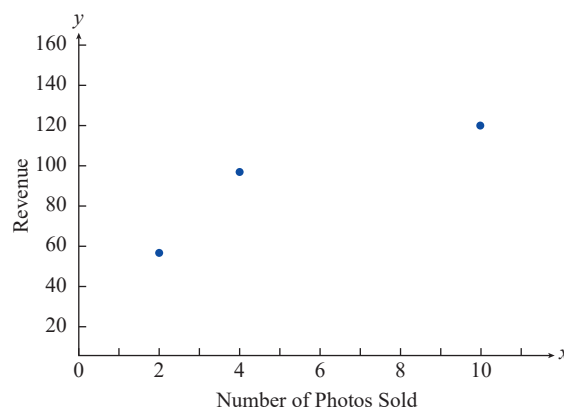

51. Joe makes a video of his friend Zach throwing a baseball as hard as he can straight up in the air. Looking at the video frame by frame later, they estimate that Zach released the ball, at a time they designate as  $t = 0$  seconds, at a height of 7 feet. The ball appears to be the same height as the top of a nearby 20-foot-tall billboard at time  $t = 0.23$  seconds on the way up and again at time  $t = 3.56$  seconds on the way down. If they use quadratic regression to fit a curve to these three points, what maximum height did the baseball reach?

 **WRITING & THINKING**

52. Without graphing, state the number of  $x$ -intercepts for each of the following functions and describe the location of the vertex in relation to the  $x$ -axis.

a.  $y = (x-2)^2$

b.  $y = (x-2)(x+2)$

c.  $y = -(x-3)(x-1)$

d.  $y = -(x-\sqrt{3})(x+\sqrt{3})$

e.  $y = x(x+1)$

f.  $y = -(x^2+1)$

 **TECHNOLOGY**

Use a graphing utility to graph each of the following quadratic functions. Then determine the vertex and  $x$ -intercepts.

53.  $f(x) = 2x^2 - 16x + 31$

54.  $f(x) = -x^2 - 2x + 3$

55.  $f(x) = x^2 - 8x - 20$

56.  $f(x) = x^2 - 4x$

57.  $f(x) = 25 - x^2$

58.  $f(x) = 3x^2 + 18x$

59.  $f(x) = x^2 + 2x + 1$

60.  $f(x) = 3x^2 - 8x + 2$

61.  $f(x) = -x^2 + 10x - 4$

62.  $f(x) = \frac{1}{2}x^2 + x - 1$

## 3.4 EXERCISES

## PRACTICE

Sketch the graphs of the following functions. Pay particular attention to intercepts, if any, and locate these accurately. See Examples 1 through 4.

1.  $f(x) = -\frac{x}{2}$

2.  $g(x) = 2x^2$

3.  $F(x) = x^{\frac{1}{2}}$

4.  $h(x) = x^{-1}$

5.  $p(x) = -\frac{2}{x}$

6.  $q(x) = -\sqrt[3]{x}$

7.  $G(x) = -|x|$

8.  $k(x) = \frac{1}{x^3}$

9.  $G(x) = \frac{\sqrt{x}}{2}$

10.  $H(x) = 0.5x^{\frac{1}{3}}$

11.  $r(x) = 3|x|$

12.  $p(x) = -\frac{1}{x^2}$

13.  $W(x) = \frac{x^4}{16}$

14.  $k(x) = \frac{x^3}{9}$

15.  $h(x) = 2\sqrt[3]{x}$

16.  $d(x) = 2x^5$

17.  $S(x) = 4x^{-2}$

18.  $f(x) = -x^2$

19.  $r(x) = \frac{\sqrt[3]{x}}{3}$

20.  $s(x) = \frac{|x|}{3}$

21.  $t(x) = \frac{x^6}{4}$

22.  $f(x) = 2\llbracket x \rrbracket$

23.  $P(x) = -\llbracket x \rrbracket$

24.  $m(x) = \left\lfloor \frac{x}{2} \right\rfloor$

25.  $f(x) = \begin{cases} 3-x & \text{if } x < -2 \\ x^{\frac{1}{3}} & \text{if } x \geq -2 \end{cases}$

26.  $g(x) = \begin{cases} -x^2 & \text{if } x \leq 1 \\ x^2 & \text{if } x > 1 \end{cases}$

27.  $r(x) = \begin{cases} \frac{1}{x} & \text{if } x < 1 \\ -x & \text{if } x > 1 \end{cases}$

28.  $p(x) = \begin{cases} x+1 & \text{if } x < -2 \\ x^3 & \text{if } -2 \leq x < 3 \\ -1-x & \text{if } x \geq 3 \end{cases}$

29.  $q(x) = \begin{cases} -1 & \text{if } x \in \mathbb{Z} \\ 1 & \text{if } x \notin \mathbb{Z} \end{cases}$

30.  $s(x) = \begin{cases} \frac{x^2}{3} & \text{if } x < 0 \\ -\frac{x^2}{3} & \text{if } x \geq 0 \end{cases}$

31.  $v(x) = \begin{cases} x^2 & \text{if } -1 \leq x \leq 1 \\ |x| & \text{if } x < -1 \text{ or } x > 1 \end{cases}$

32.  $M(x) = \begin{cases} x & \text{if } x \in \mathbb{Z} \\ -x & \text{if } x \notin \mathbb{Z} \end{cases}$

33.  $t(x) = \begin{cases} x^4 & \text{if } x \leq 1 \\ \llbracket x \rrbracket & \text{if } x > 1 \end{cases}$

34.  $N(x) = \begin{cases} x^2 & \text{if } x \in \mathbb{Z} \\ \llbracket x \rrbracket & \text{if } x \notin \mathbb{Z} \end{cases}$

$$35. h(x) = \begin{cases} -|x| & \text{if } x < 2 \\ \lceil x \rceil & \text{if } x \geq 2 \end{cases}$$

$$36. u(x) = \begin{cases} \lceil x \rceil & \text{if } x \leq 1 \\ 2x - 2 & \text{if } x > 1 \end{cases}$$

Match the following functions to their graphs.

$$37. f(x) = -2x^4$$

$$38. f(x) = -\frac{7}{9x^4}$$

$$39. f(x) = -4 \left\lceil \frac{x}{4} \right\rceil$$

$$40. f(x) = -\frac{7\sqrt[3]{x}}{3}$$

$$41. f(x) = -\frac{8}{9}|x|$$

$$42. f(x) = -4\sqrt{x}$$

$$43. f(x) = \frac{3}{7}|x|$$

$$44. f(x) = \begin{cases} -4x - 12 & \text{if } x \leq -3 \\ \frac{5}{10}x^2 & \text{if } x > -3 \end{cases}$$

$$45. f(x) = \begin{cases} -\frac{1}{3}|x| & \text{if } x < 2 \\ \left\lceil \frac{x}{2} \right\rceil & \text{if } x \geq 2 \end{cases}$$

$$46. f(x) = \begin{cases} -\frac{1}{3}|x| & \text{if } x < 2 \\ \frac{x}{2} & \text{if } x \geq 2 \end{cases}$$

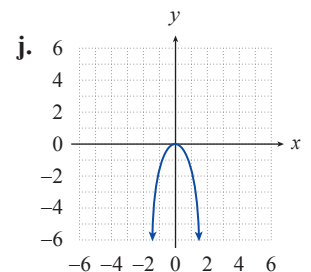
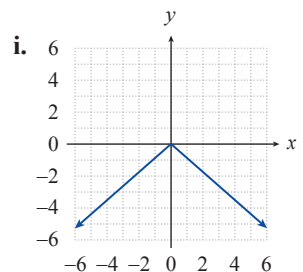
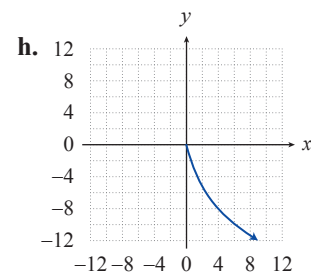
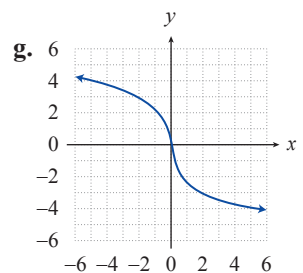
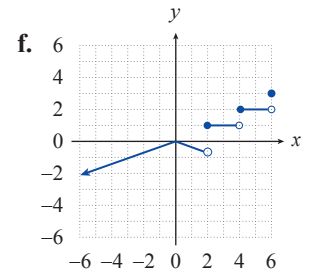
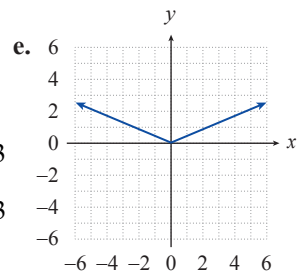
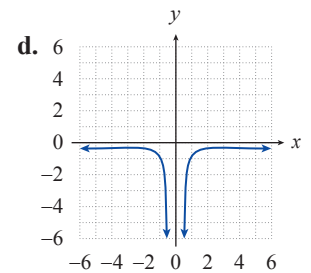
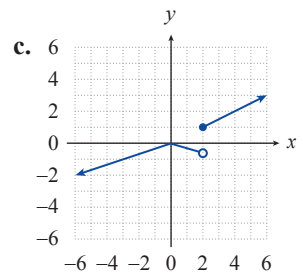
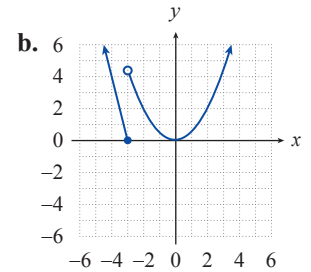
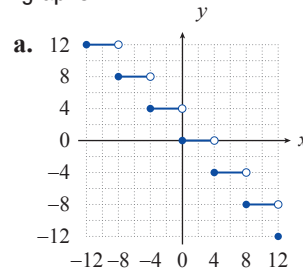

 TECHNOLOGY

Use a graphing utility to graph the following functions. Experiment with different viewing windows until you obtain a sketch that seems to capture the meaningful parts of the graph.

47.  $f(x) = 10x^5 - x^3$

48.  $g(x) = x^5 + x^2$

49.  $f(x) = x^3 - 5x^2 + x$

50.  $g(x) = \sqrt{x} - x^2$

51.  $f(x) = \sqrt{x} + 3x - 1$

52.  $g(x) = x^4 - 3x^3 + 2$

## 3.5 EXERCISES

### PRACTICE

Mathematical modeling is the process of finding a function that describes how quantities or variables relate to one another. The function is called the mathematical model. (Mathematical modeling will be studied in far greater detail in Section 3.6.) Find the mathematical model for each of the following verbal statements.

- $A$  varies directly as the product of  $b$  and  $h$ .
- $V$  varies directly as the product of four-thirds and  $r$  cubed.
- $W$  varies inversely as  $d$  squared.
- $P$  varies inversely as  $V$ .
- $r$  varies inversely as  $t$ .
- $S$  varies directly as the product of four and  $r$  squared.
- $x$  varies jointly as the cube of  $y$  and the square of  $z$ .
- $a$  varies jointly as the square of  $b$  and inversely as  $c$ .

Find the mathematical model for each of the following verbal statements and then use it to solve for the unknown variable. See Examples 1, 2, and 3.

- Suppose that  $y$  varies directly as the square root of  $x$  and that  $y = 36$  when  $x = 16$ . What is  $y$  when  $x = 20$ ?
- Suppose that  $y$  varies inversely as the cube of  $x$  and that  $y = 0.005$  when  $x = 10$ . What is  $y$  when  $x = 5$ ?
- Suppose that  $y$  varies directly as the cube root of  $x$  and that  $y = 75$  when  $x = 125$ . What is  $y$  when  $x = 128$ ?
- Suppose that  $y$  is proportional to the 5<sup>th</sup> power of  $x$  and that  $y = 96$  when  $x = 2$ . What is  $y$  when  $x = 5$ ?
- Suppose that  $y$  varies inversely as the square of  $x$  and that  $y = 3$  when  $x = 4$ . What is  $y$  when  $x = 8$ ?
- Suppose that  $y$  varies inversely as the square of  $x$  and that  $y = 8$  when  $x = 6$ . What is  $y$  when  $x = 20$ ?
- Suppose that  $y$  is inversely proportional to the 4<sup>th</sup> power of  $x$  and that  $y = 15$  when  $x = 4$ . What is  $y$  when  $x = 20$ ?
- Suppose that  $z$  varies jointly as the square of  $x$  and the cube of  $y$  and that  $z = 768$  when  $x = 4$  and  $y = 2$ . What is  $z$  when  $x = 3$  and  $y = 2$ ?
- Suppose that  $z$  is jointly proportional to  $x$  and  $y$  and that  $z = 90$  when  $x = 1.5$  and  $y = 3$ . What is  $z$  when  $x = 0.8$  and  $y = 7$ ?
- Suppose that  $z$  is jointly proportional to  $x$  and the cube of  $y$  and that  $z = 9828$  when  $x = 13$  and  $y = 6$ . What is  $z$  when  $x = 7$  and  $y = 8$ ?
- Suppose that  $z$  varies directly as the square of  $x$  and inversely as  $y$ . If  $z = 36$  when  $x = 6$  and  $y = 7$ , what value does  $z$  have when  $x = 12$  and  $y = 21$ ?
- The quantity  $F$  is jointly proportional to  $a$  and  $b$  and varies inversely as  $c$ . If  $F = 10$  when  $a = 6$ ,  $b = 5$ , and  $c = 2$ , what is the value of  $F$  when  $a = 12$ ,  $b = 6$ , and  $c = 3$ ?
- The variable  $a$  is proportional to  $\sqrt{b}$ . If  $a = 15$  when  $b = 9$ , what is  $a$  when  $b = 12$ ?

22. The variable  $a$  varies directly as  $b$ . If  $a = 3$  when  $b = 9$ , what is  $a$  when  $b = 7$ ?
23. The variable  $a$  varies directly as the square of  $b$ . If  $a = 9$  when  $b = 2$ , what is  $a$  when  $b = 4$ ?
24. The variable  $a$  is proportional to the square of  $b$  and varies inversely as the square root of  $c$ . If  $a = 108$  when  $b = 6$  and  $c = 4$ , what is  $a$  when  $b = 4$  and  $c = 9$ ?
25. The variable  $a$  varies jointly as  $b$  and  $c$ . If  $a = 210$  when  $b = 14$  and  $c = 5$ , what is the value of  $a$  when  $b = 6$  and  $c = 6$ ?
26. The variable  $a$  varies directly as the cube of  $b$  and inversely as  $c$ . If  $a = 9$  when  $b = 6$  and  $c = 7$ , what is the value of  $a$  when  $b = 3$  and  $c = 21$ ?

### 🔗 APPLICATIONS

27. The distance that an object falls from rest, when air resistance is negligible, varies directly as the square of the time. A stone dropped from rest travels 144 feet in the first 3 seconds. How far does it travel in the first 4 seconds?
28. A record store manager observes that the number of records sold seems to vary inversely as the price per record. If the store sells 840 records per week when the price per record is \$15.99, how many does he expect to sell if he lowers the price to \$14.99?
29. A person's Body Mass Index (BMI) is used by physicians to determine if a patient's weight falls within reasonable guidelines relative to the patient's height. The BMI varies directly as a person's weight in pounds and inversely as the square of a person's height in inches. Given that a 6-foot-tall man weighing 180 pounds has a BMI of 24.41, what is the BMI of a woman weighing 120 pounds with a height of 5 feet 4 inches?

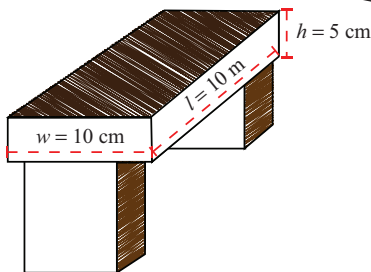
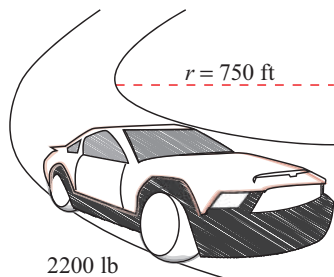

30. The force necessary to keep a car from skidding as it travels along a circular arc varies directly as the product of the weight of the car and the square of the car's speed, and inversely as the radius of the arc. If it takes 241 pounds of force to keep a 2200-pound car moving 35 miles per hour on an arc whose radius is 750 feet, how many pounds of force would be required if the car were to travel 40 miles per hour?
31. If a beam of width  $w$ , height  $h$ , and length  $l$  is supported at both ends, the maximum load that the beam can hold varies directly as the product of the width and the square of the height, and inversely as the length. A given beam 10 meters long with a width of 10 centimeters and a height of 5 centimeters can hold a load of 200 kilograms when the beam is supported at both ends. If the supports are moved inward so that the effective length of the beam is shorter, the beam can support more load. What should the distance between the supports be if the beam has to hold a load of 300 kilograms?
32. In a simple electric circuit connecting a battery and a light bulb, the current  $I$  varies directly as the voltage  $V$  but inversely as the resistance  $R$ . When a 1.5-volt battery is connected to a light bulb with resistance 0.3 ohms ( $\Omega$ ), the current that travels through the circuit is 5 amps. Find the current if the same light bulb is connected to a 6-volt battery.

33. The amount of time it takes for water to flow down a drainage pipe is inversely proportional to the square of the radius of the pipe. If a pipe of radius 1 cm can empty a sink in 25 seconds, find the radius of a pipe that would allow the sink to drain completely in 16 seconds.
34. The perimeter of a square varies directly as the length of the side of a square. If the perimeter of a square is 308 inches when one side is 77 inches, what is the perimeter of a square when the side is 133 inches?
35. The circumference of a circle varies directly as the diameter. A circular pizza slice has a length of 6.5 inches when the circumference of the pizza is 40.82 inches. What would the circumference of a pizza be if the pizza slice has a length of 5.5 inches?
36. The volume of a cylinder varies jointly as its height and the square of its radius. If a cylinder has the measurements  $V = 301.44$  cubic inches,  $r = 4$  inches, and  $h = 6$  inches, what is the volume of a cylinder that has a radius of 6 inches and a height of 8 inches?
37. The surface area of a right circular cylinder varies directly as the sum of the radius times the height and the square of the radius. With a height of 18 in. and a radius of 7 in., the surface area of a right circular cylinder is 1099 in.<sup>2</sup> What would the surface area be if the height equaled 5 in. and the radius equaled 3.2 in.?
38. The gravitational force,  $F$ , between an object and Earth is inversely proportional to the square of the distance from the object to the center of Earth. If an astronaut weighs 193 pounds on the surface of Earth, what will this astronaut weigh 1000 miles above Earth? Assume that the radius of Earth is 4000 miles.
39. In an electrical schematic, the voltage across a load is directly proportional to the power used by the load but inversely proportional to the current through the load. If a computer is connected to a wall outlet and the computer needs 18 volts to run and absorbs 54 watts of power, the current through the computer is 3 amps. Find the power absorbed by the computer if the same 18-volt computer is attached to a circuit with a loop current of 0.5 amps.
40. A hot dog vendor has determined that the number of hot dogs she sells a day is inversely proportional to the price she charges. The vendor wants to decide if increasing her price by 50 cents will drive away too many customers. On average, she sells 80 hot dogs a day at a price of \$3.50. How many hot dogs can she expect to sell if the price is increased by 50 cents?
41. The price of gasoline purchased varies directly with the number of gallons of gas purchased. If 16 gallons of gas are purchased for \$34.40, what is the price of purchasing 20 gallons?

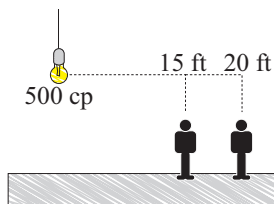

42. The illumination  $I$  of a light source varies directly as the intensity  $i$  and inversely as the square of the distance  $d$ . If a light source with an intensity of 500 cp (candlepower) has an illumination of 20 fc (foot-candles) at a distance of 15 feet, what is the illumination at a distance of 20 feet?

43. The resistance of a wire varies directly as its length and inversely as the square of the diameter. When a wire is 500 feet long and has a diameter of 0.015 in., it has a resistance of 20 ohms. What is the resistance of a wire that is 1200 feet long and has a diameter of 0.025 in.?

In Exercises 44–45, use Hooke's Law, which says that the force exerted on a spring varies directly with the distance that the spring is stretched.

44. A hanging spring will stretch 9 cm if a weight of 15 g is placed on the end of the spring. How far will the spring stretch if the weight is increased to 20 g?
45. If a 32-pound weight suspended on a spring scale stretches the spring 17 inches, how far will a 37-pound weight stretch the spring?

In Exercises 46–47, use Boyle's Law, which says that at a constant temperature, the volume of a gas in a container varies inversely as the pressure on the gas.

46. If the volume is 100 cubic centimeters under a pressure of 800 pascals, what would be the volume of the gas if the pressure was decreased to 400 pascals?
47. If a gas has a volume of 252 cubic inches under a pressure of 5 pounds per square inch, what will its volume be if the pressure is increased to 6 pounds per square inch?

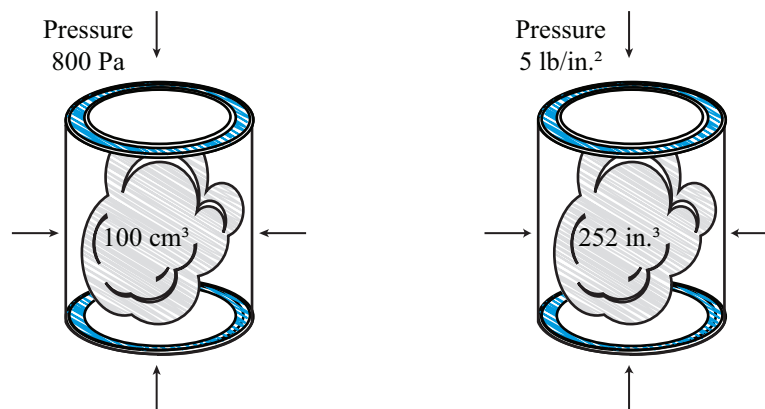

In Exercises 48–50, express the indicated quantities as functions of the other variables. See Example 4.

48. A person's body mass index (BMI) varies directly as a person's weight in pounds and inversely as the square of a person's height in inches. Given that a 6-foot-tall man weighing 180 pounds has a BMI of 24.41, express BMI as a function of weight ( $w$ ) and height ( $h$ ).
49. The electric pressure varies directly as the square of the surface charge density ( $\sigma$ ) and inversely as the permittivity ( $\epsilon$ ). If the surface charge density is 6 coulombs per unit area and the free space permittivity equals 3, the pressure is equal to 6 N/m<sup>2</sup>. Express the electric pressure as a function of surface charge density and permittivity.
50. The volume of a right circular cylinder varies directly as the radius squared times the height of the cylinder. If the radius is 7 and the height is 4, the volume is equal to 615.44. Determine the expression of the volume of a right circular cylinder.

For instance, population growth over a long span of time always seems to show either an increase in the rate of growth or else a tapering off in the rate, neither of which is linear behavior. And the vertex that is present in the graph of any quadratic function also doesn't seem to be something typically seen in graphs of population growth. Is there a better assumption for the shape of the graph? The answer is yes, and we will return to the question of curve fitting several more times as we gain experience with more classes of functions.

## 3.6 EXERCISES

### APPLICATIONS

Construct a mathematical model as appropriate for each of the following situations, and then use your model to answer the accompanying questions.

1. A tinsmith wants to make a small windowsill planter from a  $20 \text{ cm} \times 60 \text{ cm}$  sheet of copper. She'll form it by cutting equally sized squares from each of the four corners of the sheet, folding up the resulting flaps to form the sides of the planter, and then soldering the four vertical edges.
  - a. Construct a model for the volume of the planter based on the side length of the square cut from each corner, and determine the feasible domain for the model.
  - b. Is it possible to construct such a planter with a volume of  $2000 \text{ cm}^3$  or larger?
  - c. What is the maximum possible volume, rounded to the nearest whole number?
  - d. If she wants the ratio of the planter's width to height to be 2, what will be the ratio of its length to width?
  
2. Suppose the tinsmith of the previous problem wants to construct a similar planter (out of a sheet of copper with dimensions to be determined) but with ratios of height to width to length of  $1:2:3$ .
  - a. Construct a model for the volume of such a planter based on the height.
  - b. What must be the ratio of the width to length of the original sheet of copper?
  - c. Rounding to the nearest whole number, what minimum height of such a planter will have a volume of  $2000 \text{ cm}^3$  or larger?
  
3. A car dealership wants to try out a new leasing arrangement, which will allow a buyer to trade a car back in to the dealership for a certain amount of credit at any time throughout the first three years of ownership. For a car in good condition, the arrangement will value the car at  $\frac{1}{3}$  the original price at the end of three years, and will depreciate the value of the car linearly over the course of the three years.
  - a. Construct a model for the value at time  $t$  (in years) of a car with initial purchase price  $P$ , for  $0 \leq t \leq 3$ .
  - b. At what point in time does a car have half its original value?
  - c. What is the value of a car at the end of the first year?

4. Picture a person standing a certain distance away from a streetlamp at night, with the streetlamp casting a shadow of the person.
- Find a model for the length  $s$  of the shadow of a person of height  $h$  cast by a 15-foot-tall streetlamp  $d$  feet away.
  - For a 5-foot-tall person, express the length  $s$  as a function of  $d$ .
  - How does the shadow of a 5-foot-tall person compare to that of a 6-foot-tall person when both are standing 20 feet from the streetlamp?
  - How far away does the 6-foot-tall person have to be for the person's shadow to be 6 feet long?
5. Consider a point on an arbitrary nonvertical line in the plane.
- Find a model for the distance  $d$  between a point on the line  $y = mx + b$  and the origin.
  - What form does the model take for lines that are horizontal?
  - What form does the model take for lines that pass through the origin?
  - What form does the model take for a line that passes through the origin and has slope  $\sqrt{3}$ ?
6.
  - Find a model for the product of two nonnegative numbers whose sum is 10.
  - What are the largest and smallest possible products?
7.
  - Find a model for the sum of the cubes of two nonnegative numbers whose sum is 10.
  - Expressing the sum of the cubes as a function of one variable, graph the sum.
  - What are the largest and smallest possible sums?
8.
  - Find a model for the Body Mass Index (BMI) of a person, given that BMI varies directly as a person's weight in pounds and inversely as the square of the person's height in inches.
  - With the additional information that a 6 ft tall person weighing 175 lb has a BMI of 23.73, what is the BMI of someone 5 ft, 6 in. tall weighing 140 lb?
  - How much weight would the 5 ft, 6 in. tall person from part b. need to gain or lose to have a BMI of 22?
  - What is the BMI for a person with the same weight but two inches taller than the 5 ft, 6 in. person?
9.
  - Use the gravitational-attraction model of Example 3 to determine how far away from the surface of Earth a person would have to be to feel the force of attraction felt on the moon (about one-sixth that felt on Earth).
  - How does this distance compare to Earth's radius?
  - Why do astronauts appear to be weightless when they are in orbit so much closer to Earth?
10.
  - Find a model for the area of sheet metal that must be used to make a cylindrical can, including both top and bottom, in terms of the can's radius  $r$  and height  $h$ .
  - Modify the model to be a function of  $r$  only, given that the volume of the can is to be  $1000 \text{ cm}^3$  (1 liter).
  -  Estimate the value of  $r$  that will minimize the area of metal required.

11. a. Find a model for the surface area of a cube of side length  $x$  in terms of the cube's volume.  
b. What is the surface area of a cube that has a volume of  $1000 \text{ mm}^3$ ?
12. a. Find a model for the surface area of a sphere of radius  $r$  in terms of the sphere's volume.  
b. What is the surface area of a sphere that has a volume of  $\frac{500}{3} \text{ mm}^3$ ?
13. Maria plans to build a rectangular dog run with an area of  $1800 \text{ ft}^2$  at the edge of her property. She wants to use a solid fence that costs  $\$6/\text{ft}$  for the side that will sit on the edge of her property, but is willing to use fencing that only costs  $\$2/\text{ft}$  for the other three sides.
- a. Find a model for the total cost of the fencing.  
b. Estimate the length of solid fence that will minimize her total cost.
14. *Restaurante Caro* frequently offers a special prix fixe meal and has been charging  $\$150$  per person for the event. At that price, they've been averaging 30 customers each time. Their marketing firm has convinced them that they'll gain a customer for every dollar they lower the cost of the event, and conversely lose a customer for every dollar they raise the cost. Their fixed cost per event is  $\$1500$  and preparing each customer's meal costs an additional  $\$20$ .
- a. Find the cost, revenue, and profit functions for these prix fixe events.  
b. What are the break-even points in terms of customers served?  
c. Is there a number of customers that will maximize their profit?  
d. If so, what price per person should they charge?
15. A ceramicist made 6 bowls of a certain style and sold them for  $\$12$  each, just breaking even at that price. Each time she starts up her kiln and makes any number of the bowls, she has a fixed cost of  $\$36$ , and there is an additional cost in materials to make each bowl. Polling the six customers who bought the bowls, she learned that only half would have bought the same bowl at a price of  $\$21$ .
- a. Assuming a linear relationship between price per bowl and the number of bowls sold, and given the information she has, find the revenue, cost, and profit functions for selling a certain number of bowls.  
b. Is there another break-even point for her product?  
c. Is there an ideal number of bowls she should make in each production run?  
d. If so, what should she charge per bowl and what maximum profit can she expect?

Interpolate and extrapolate, as appropriate, to answer the questions with the given data. Use a graphing utility to answer questions marked with .

16. Use the linear and quadratic functions of best fit modeling the US population data in Tables 1 and 2 of this section to answer the following questions.
- How do the interpolated populations for 1955 compare in the two models?
  - What is the extrapolated linear-model population for the year 1800? How do you interpret this result?
  - What is the calculated quadratic-model population for the year 1800? How does this compare to the actual population in 1800 on which the quadratic model is based?
  - Imagine tracing the quadratic model population far back in time, before the US actually existed as a country. What is the extrapolated quadratic model population in the year 1000? How do you interpret this result?
17.  The table below shows the height at half-second intervals of a rock that breaks free from the top of a 200-foot-tall cliff and falls without obstruction to the river below.

| Time $t$<br>(in seconds) | Height<br>(in feet) |
|--------------------------|---------------------|
| 0                        | 200                 |
| 0.5                      | 196                 |
| 1.0                      | 184                 |
| 1.5                      | 164                 |
| 2.0                      | 136                 |
| 2.5                      | 100                 |
| 3.0                      | 56                  |

- Graph the heights (either by hand or with a graphing utility) and estimate the time the rock hits the water.
- Find the linear function of best fit that models the height of the rock, and graph the function along with the given heights. By the linear model, what is the extrapolated time when the rock hits the water? What is the calculated linear-model height of the rock at time  $t = 0$ ?
- Find the quadratic function of best fit that models the height of the rock, and graph the function along with the given heights. By the quadratic model, what is the extrapolated time when the rock hits the water? What is the calculated quadratic-model height of the rock at time  $t = 0$ ?
- Which model appears to be more appropriate?

18. 🐾 Karen bought a puppy and has been tracking its weight at the end of each month since it was born. She was told by the dog's breeder that the dog should have an adult weight somewhere between 40 and 45 pounds.

| End of Month | Weight<br>(in pounds) |
|--------------|-----------------------|
| 1            | 3                     |
| 2            | 5                     |
| 3            | 8                     |
| 4            | 11                    |
| 5            | 17                    |
| 6            | 22                    |
| 7            | 28                    |
| 8            | 32                    |
| 9            | 35                    |
| 10           | 38                    |
| 11           | 40                    |
| 12           | 42                    |

- a. Find the linear function of best fit that models the dog's weight, and graph the function along with the given weights. By the linear model, what is the extrapolated weight at the end of the second year? How do you interpret this result?
- b. Find the quadratic function of best fit that models the dog's weight, and graph the function along with the given weights. By the quadratic model, what is the extrapolated weight at the end of the second year? How do you interpret this result?

## 4.1 EXERCISES

### 💡 PRACTICE

For each function or graph below, determine the basic function that has been shifted, reflected, stretched, or compressed.

1.  $f(x) = -(1-x)^2 + 2$

2.  $f(x) = \frac{1}{x-4} + 5$

3.  $f(x) = \sqrt[3]{x+6} - 2$

4.  $f(x) = -2 + 2|x-3|$

5.  $f(x) = \sqrt{x+2} - 5$

6.  $f(x) = \lfloor -2-x \rfloor$

7.  $f(x) = \frac{1}{(x+2)^2} + 1$

8.  $f(x) = \frac{\sqrt{-x}}{2} + 4$

9.  $f(x) = (x+6)^3$

10.  $f(x) = (1-2x)^3$

11.  $f(x) = 3\left|\frac{x}{2} - 1\right|$

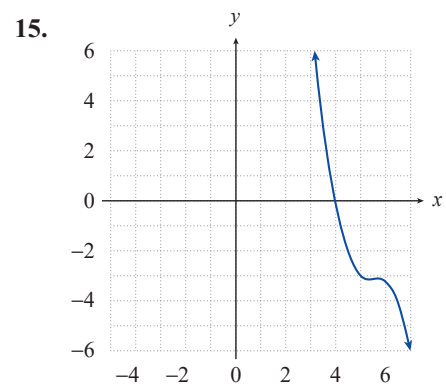
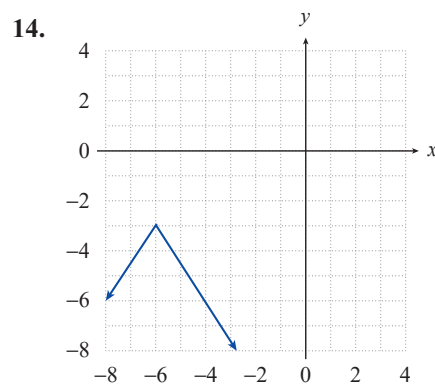
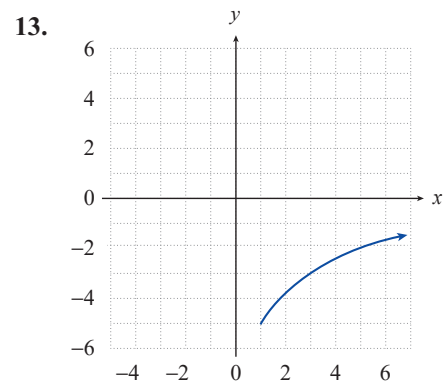
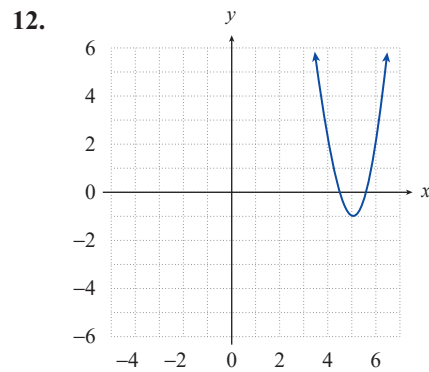

Sketch the graphs of the following functions by first identifying the more basic functions that have been shifted, reflected, stretched, or compressed. Then determine the domain and range of each function. See Examples 1 through 6.

16.  $f(x) = (x+2)^3$

17.  $G(x) = |x-4|$

18.  $p(x) = -(x+1)^2 + 2$

19.  $g(x) = \sqrt{x+3} - 1$

20.  $q(x) = (1-x)^2$

21.  $r(x) = -\sqrt[3]{x}$

22.  $s(x) = \sqrt{2-x}$

23.  $F(x) = \frac{|x+2|}{3} + 3$

24.  $w(x) = \frac{1}{(x-3)^2}$

25.  $v(x) = \frac{1}{3x} - 2$

26.  $f(x) = \frac{1}{2-x}$

27.  $k(x) = \sqrt{-x} + 2$

28.  $b(x) = \sqrt[3]{x+2} - 5$

29.  $b(x) = \lceil x-4 \rceil + 4$

30.  $R(x) = 4 - 2|x|$

31.  $S(x) = (3-x)^3$

32.  $g(x) = -\frac{1}{x+1}$

33.  $h(x) = \frac{x^2}{2} - 3$

34.  $W(x) = 1 - |4-x|$

35.  $W(x) = -\frac{|x-1|}{4}$

36.  $S(x) = \frac{1}{x^2} + 3$

37.  $V(x) = -3\sqrt{x-1} + 2$

38.  $f(x) = \sqrt{2x-2} - 2$

39.  $g(x) = (2x-3)^2 + 1$

40.  $f(x) = |1-2x| - 1$

41.  $g(x) = -(3x+3)^3$

42.  $g(x) = x^2 - 6x + 9$  (**Hint:** Find a better way to write the function.)

43.  $h(x) = \frac{|x|}{x}$  (**Hint:** Evaluate  $h$  at a few points to understand its behavior.)

44.  $W(x) = \frac{x-1}{|x-1|}$

45.  $s(x) = \lceil x-2 \rceil$

Write a formula for each of the functions described.

46. Use the function  $g(x) = x^2$ . Move the function 3 units to the left and 4 units down.

47. Use the function  $g(x) = x^2$ . Move the function 4 units to the right and 2 units up.

48. Use the function  $g(x) = x^2$ . Reflect the function across the  $x$ -axis and move it 6 units up.

49. Use the function  $g(x) = x^2$ . Move the function 2 units to the right and reflect across the  $y$ -axis.

50. Use the function  $g(x) = x^3$ . Compress the function horizontally by a factor of  $\frac{1}{3}$  and move it 1 unit down.
51. Use the function  $g(x) = x^3$ . Move the function 1 unit to the left and reflect across the  $y$ -axis.
52. Use the function  $g(x) = x^3$ . Move the function 10 units to the right and 4 units up.
53. Use the function  $g(x) = \sqrt{x}$ . Move the function 5 units to the left and reflect across the  $x$ -axis.
54. Use the function  $g(x) = \sqrt{x}$ . Reflect the function across the  $y$ -axis and move it 3 units down.
55. Use the function  $g(x) = \sqrt{x}$ . Stretch the function horizontally by a factor of 2, reflect it with respect to the  $y$ -axis, and move it 3 units up.
56. Use the function  $g(x) = |x|$ . Move the function 7 units to the left, reflect across the  $x$ -axis, and reflect across the  $y$ -axis.
57. Use the function  $g(x) = |x|$ . Move the function 8 units to the right, 2 units up, and reflect across the  $x$ -axis.

Use your knowledge about transformations to find a possible formula for the function  $f(x)$  given its graph.

58.

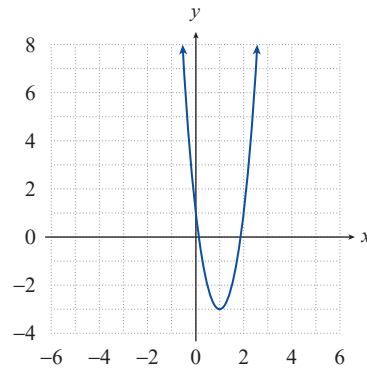

60.

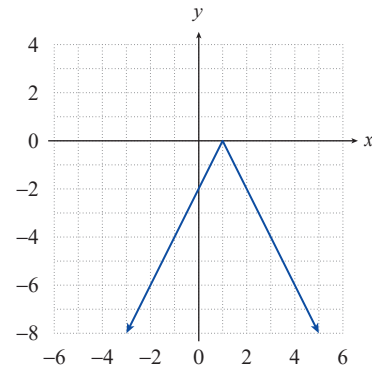

59.

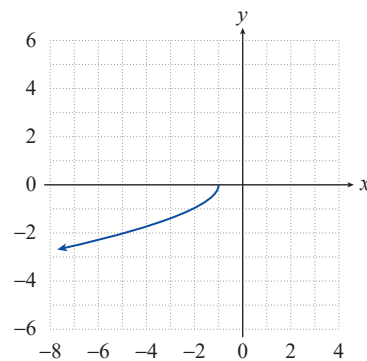

61.

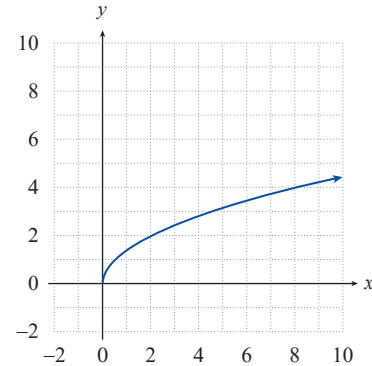

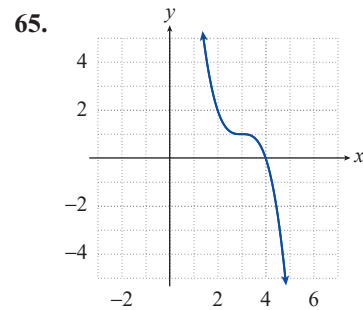
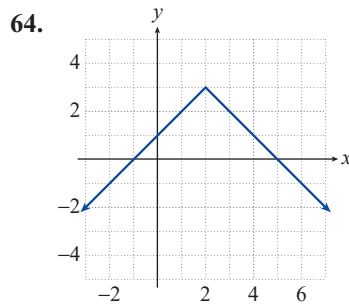
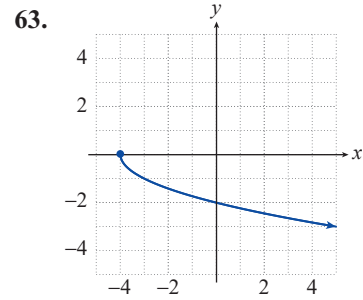
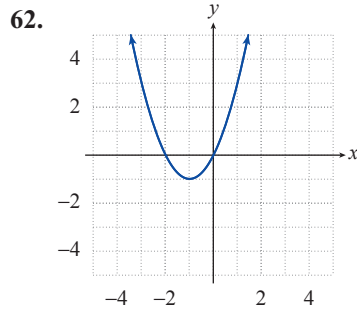

TECHNOLOGY

Mentally sketch the graph of the given function by identifying the basic shape that has been shifted, reflected, stretched, or compressed. Then use a graphing utility to graph the function and check your reasoning

66.  $f(x) = -2(3-x)^3 + 5$

67.  $f(x) = \frac{3}{x+5} - 1$

68.  $f(x) = \frac{-1}{(x-2)^2} - 3$

69.  $f(x) = -3|x+2| - 4$

70.  $f(x) = -\sqrt{1-x} + 2$

71.  $f(x) = \sqrt[3]{2+x} - 1$

Write a possible equation for the function depicted on the graphing utility. The function is shown in a  $[-10, 10]$  by  $[-10, 10]$  viewing window.

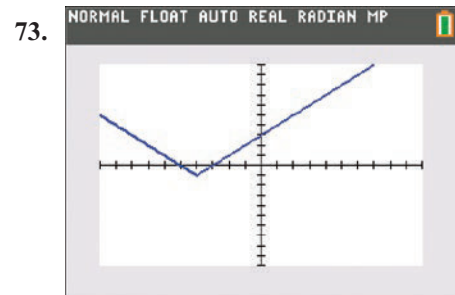
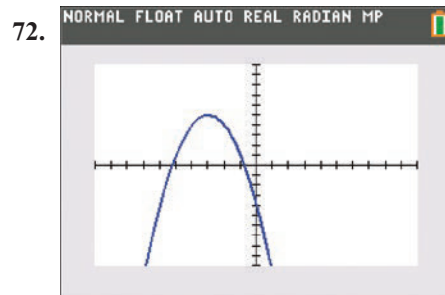

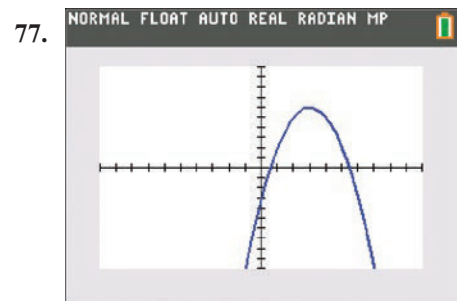
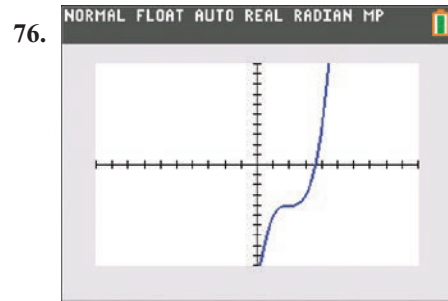
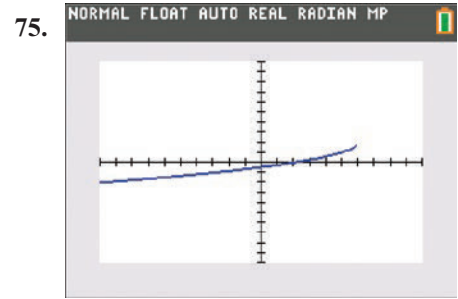
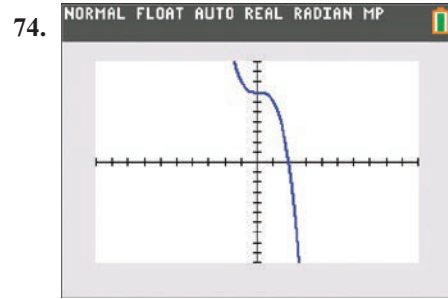

**Solution**

a. Since  $f(c) - f(b) > 0$  and  $c - b > 0$ ,  
 $\frac{f(c) - f(b)}{c - b} > 0$ . That is, the average  
 rate of change of  $f$  is positive on  $[b, c]$ .

b. Since  $f(b) - f(a) < 0$  but  $b - a > 0$ ,  
 $\frac{f(b) - f(a)}{b - a} < 0$ . That is, the average  
 rate of change of  $f$  is negative on  
 $[a, b]$ .

c. Since  $f(c) = f(a)$ ,  $\frac{f(c) - f(a)}{c - a} = 0$ . That is, the average rate of change of  $f$  is  
 zero on  $[a, c]$ .

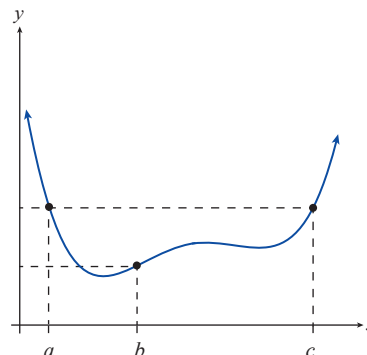
**FIGURE 16****4.2 EXERCISES****PRACTICE**

Determine if each of the following relations is a function. If so, determine whether it is even, odd, or neither. Also determine if it has  $y$ -axis symmetry,  $x$ -axis symmetry, origin symmetry, or none of the above, and then sketch the graph of the relation. See Example 1.

1.  $f(x) = |x| + 3$

2.  $g(x) = x^3$

3.  $h(x) = x^3 - 1$

4.  $w(x) = \sqrt[3]{x}$

5.  $x = -y^2$

6.  $3y - 2x = 1$

7.  $x + y = 1$

8.  $F(x) = (x - 1)^2$

9.  $x = y^2 + 1$

10.  $x = 2|y|$

11.  $g(x) = \frac{x^2}{5} - 5$

12.  $s(x) = \left\lfloor x + \frac{1}{2} \right\rfloor$

13.  $m(x) = \sqrt[3]{x} - 1$

14.  $xy = 2$

15.  $x + y^2 = 3$

For each of the following functions, find the open intervals of monotonicity where the function is increasing, decreasing, or constant. See Examples 2 and 3.

16.  $f(x) = (x + 3)^2$

17.  $g(x) = -|x - 2|$

18.  $h(x) = \frac{1}{x - 1}$

19.  $H(x) = \frac{1}{(x + 3)^2}$

20.  $G(x) = \sqrt{x + 1}$

21.  $F(x) = -2$

22.  $p(x) = -30|x - 1|$

23.  $q(x) = (4 - x)^2 + 1$

24.  $r(x) = \frac{(x - 7)^4}{-2} + 4$

25.  $P(x) = \begin{cases} (x + 3)^2 & \text{if } x < -1 \\ 1 & \text{if } x \geq -1 \end{cases}$

26.  $Q(x) = \begin{cases} |x - 1| & \text{if } x \leq 3 \\ 5 - x & \text{if } x > 3 \end{cases}$

Using the graph of each of the following functions determine **a.** the locations and types of the local extrema, and **b.** the values of the local extrema. See Example 4.

27.

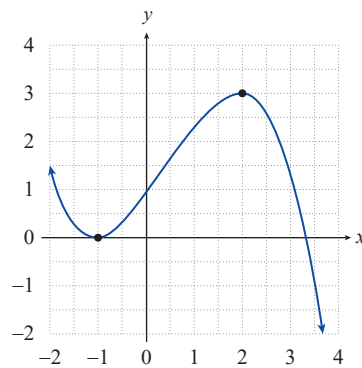

28.

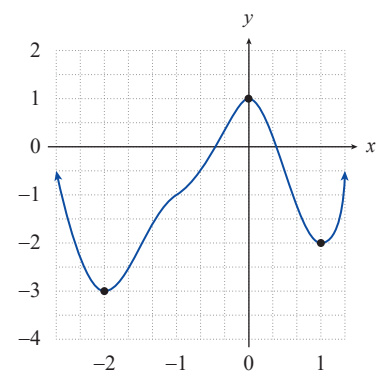

Using the graph and given formula for each of the following functions, determine **a.** the locations and types of the local extrema, and **b.** the values of the local extrema.

29.  $f(x) = -2x^3 + 3x^2 + 12x - 5$

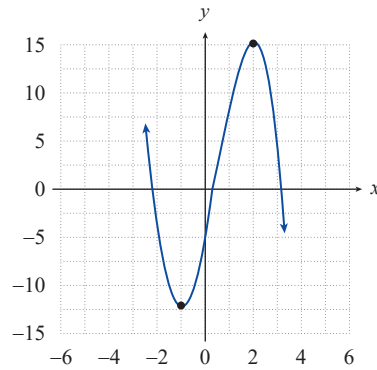

30.  $f(x) = \frac{x^3}{3} - \frac{x^2}{2} - 6x$

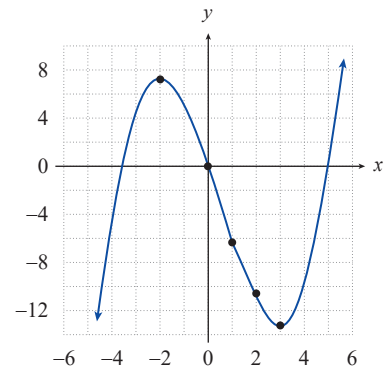

31.  $f(x) = \frac{x^4}{4} - \frac{x^3}{3} - 3x^2 + 7$

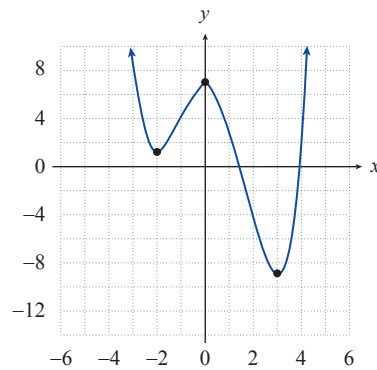

32.  $f(x) = \frac{x^4}{2} - \frac{4x^3}{3} - x^2 + 4x$

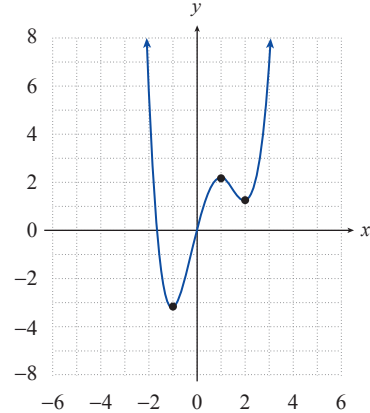

For each of the following functions, determine **a.** the locations and types of the local extrema, and **b.** the values of the local extrema. A sketch of the graph may be helpful.

33.  $f(x) = (x-5)^2 + 2$

34.  $f(x) = -(x+1)^2 + 3$

35.  $f(x) = -x^2 - 4x - 3$

36.  $f(x) = x^2 - 10x + 27$

37.  $f(x) = 5|x-3| - 2$

38.  $f(x) = -|x+1| + 2$

For each given function and interval, determine the average rate of change of the function over the interval. See Example 5.

39.  $f(x) = x^3 - 2x$ ;  $[1, 3]$

40.  $f(x) = 3x + 17$ ;  $[-2, 0]$

41.  $f(x) = x^2 - 5x + 3$ ;  $[2, 5]$

42.  $f(x) = -x^3 + x^2 - 7$ ;  $[-1, 1]$

43.  $f(x) = \sqrt{x}$ ;  $[2, 4]$

44.  $f(x) = -x^2 + 3x - 1$ ;  $[-2, 1]$

45.  $f(x) = x^2 - 3$ ;  $[c, c+h]$

46.  $f(x) = -3x^2 + 2x - 5$ ;  $[c, c+h]$

47.  $f(x) = \frac{1}{x}$ ;  $[3, 4]$

48.  $f(x) = \frac{2}{x+1}$ ;  $[-3, -2]$

Use each given graph of a function and the marked locations on the  $x$ -axis as endpoints to determine intervals over which the average rate of change of the function is **a.** positive, **b.** negative, **c.** zero. See Example 6.

49.

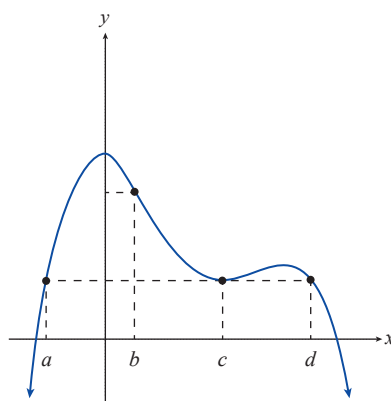

50.

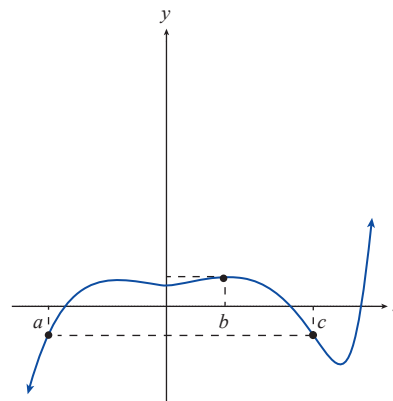

### APPLICATIONS

51. During the summer months, the water level of a garden pool varies as water is added and as it evaporates. On May 1<sup>st</sup> the pool was 3.4 feet deep. After a steady and linear increase due to rain, the depth had increased to 4.9 feet on June 1<sup>st</sup>. By July 1<sup>st</sup> the water level had decreased linearly to 4.2 feet. Knowing that the pool would be covered for the winter, the owner filled the pool (in an essentially linear fashion) until it reached 5 feet on August 1<sup>st</sup>. Graph the water level as a function of time and determine the open intervals of monotonicity.

52. The profit made by a hot dog vendor is given by the function

$$P(x) = \begin{cases} 2x - 3 & \text{if } x \geq 0 \text{ and } x < 7 \\ \frac{1}{4}x^2 & \text{if } x \geq 7 \end{cases}$$

where  $x$  is the number of hot dogs sold. Graph the profit function and determine the open intervals of monotonicity.

53. The cost incurred by a newspaper stand is given by the function

$$C(x) = \begin{cases} -2\sqrt{x} + 8 & \text{if } x \geq 0 \text{ and } x < 3 \\ -x + 8 & \text{if } x \geq 3 \end{cases}$$

where  $x$  is the number of newspapers sold. Graph the cost function and determine the open intervals of monotonicity.

### WRITING & THINKING

54. Determine the average rate of change of the function  $f(x) = 5x - 19$  over each of the following intervals:  $[-3, -2]$ ,  $[1, 7]$ ,  $[c, c + h]$ . What do you conclude from your calculations?
55. Let  $f(x) = mx + b$ , where  $m$  and  $b$  are both unspecified constants. Determine the average rate of change of  $f$  over several different intervals of your choice. What do you conclude from your calculations?
56. Let  $f(x) = 3x^2 - 7x + 2$ . Find the difference quotient of  $f$  at  $c$  with increment  $h$ . What happens to this difference quotient as the increment  $h$  becomes very small?
57. Let  $f(x) = px^2 + qx + r$ , where  $p$ ,  $q$ , and  $r$  are unspecified constants. Find the difference quotient of  $f$  at  $c$  with increment  $h$ . What happens to this difference quotient as the increment  $h$  becomes very small?
58. What can be deduced about the average rate of change of a function if the function is increasing over the interval?
59. What can be deduced about the monotonicity of a function over an interval if the function's average rate of change is positive over the interval?
60. What can be deduced about the monotonicity of a function over an interval if the function's average rate of change is zero over the interval?

## 4.3 EXERCISES

## PRACTICE

In each of the following exercises, use the information given to determine **a.**  $(f+g)(-1)$ ,

**b.**  $(f-g)(-1)$ , **c.**  $(fg)(-1)$ , and **d.**  $\left(\frac{f}{g}\right)(-1)$ . See Examples 1, 2, and 3.

- $f(-1) = -3$  and  $g(-1) = 5$
- $f(-1) = 0$  and  $g(-1) = -1$
- $f(x) = x^2 - 3$  and  $g(x) = x$
- $f(x) = \sqrt[3]{x}$  and  $g(x) = x - 1$
- $f(-1) = 15$  and  $g(-1) = -3$
- $f(x) = \frac{x+5}{2}$  and  $g(x) = 6x$
- $f(x) = x^4 + 1$  and  $g(x) = x^{11} + 2$
- $f(x) = \frac{6-x}{2}$  and  $g(x) = \sqrt{\frac{x}{-4}}$
- $f = \{(5, 2), (0, -1), (-1, 3), (-2, 4)\}$  and  $g = \{(-1, 3), (0, 5)\}$
- $f = \{(3, 15), (2, -1), (-1, 1)\}$  and  $g(x) = -2$

11.

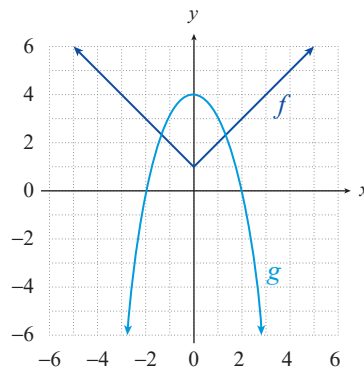

12.

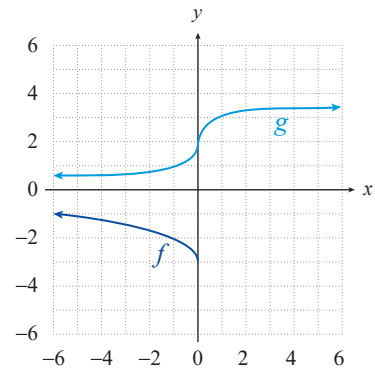

13.

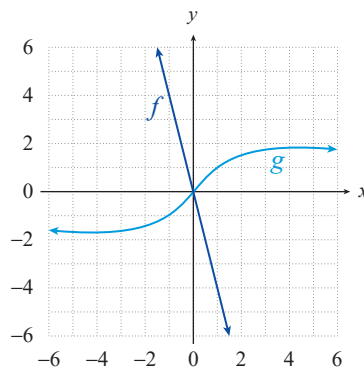

14.

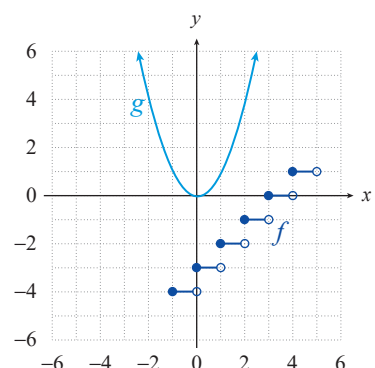

In each of the following exercises, find **a.** the formula and domain for  $(f+g)$  and

**b.** the formula and domain for  $\frac{f}{g}$ . See Examples 2 and 3.

- $f(x) = |x|$  and  $g(x) = \sqrt{x}$
- $f(x) = x^2 - 1$  and  $g(x) = \sqrt[3]{x}$
- $f(x) = x - 1$  and  $g(x) = x^2 - 1$
- $f(x) = x^{\frac{3}{2}}$  and  $g(x) = x - 3$

19.  $f(x) = 3x$  and  $g(x) = x^3 - 8$       20.  $f(x) = x^3 + 4$  and  $g(x) = \sqrt{x-2}$   
 21.  $f(x) = -2x^2$  and  $g(x) = |x+4|$       22.  $f(x) = 6x - 1$  and  $g(x) = x^{\frac{2}{3}}$

In each of the following exercises, use the information given to determine  $(f \circ g)(3)$ . See Examples 4 and 5.

23.  $f(-5) = 2$  and  $g(3) = -5$       24.  $f(\pi) = \pi^2$  and  $g(3) = \pi$   
 25.  $f(x) = x^2 - 3$  and  $g(x) = \sqrt{x}$       26.  $f(x) = \sqrt{x^2 - 9}$  and  $g(x) = 1 - 2x$   
 27.  $f(x) = 2 + \sqrt{x}$  and  $g(x) = x^3 + x^2$       28.  $f(x) = x^{\frac{3}{2}} - 3$  and  $g(x) = \left| \frac{4x}{3} \right|$   
 29.  $f(x) = \sqrt{x+6}$  and  $g(x) = \sqrt{4x-3}$   
 30.  $f(x) = \sqrt{\frac{3x}{14}}$  and  $g(x) = x^4 - x^3 - x^2 - x$

31.

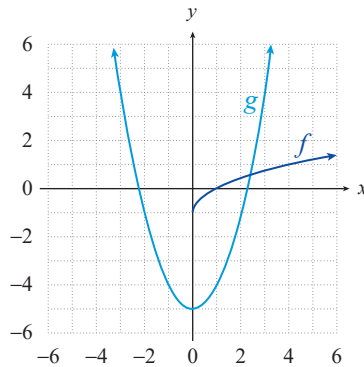

32.

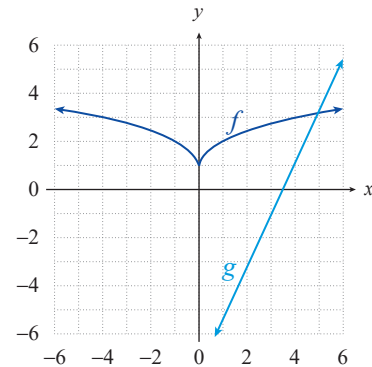

33.

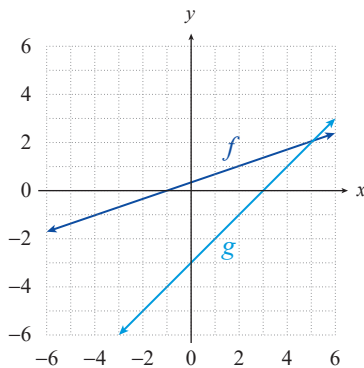

In each of the following exercises, find **a.** the formula and domain for  $f \circ g$  and **b.** the formula and domain for  $g \circ f$ . See Example 6.

34.  $f(x) = \frac{1}{x}$  and  $g(x) = x - 1$       35.  $f(x) = \frac{4x-2}{3}$  and  $g(x) = \frac{1}{x}$   
 36.  $f(x) = 1 - x$  and  $g(x) = \sqrt{x}$       37.  $f(x) = |x-3|$  and  $g(x) = x^3 + 1$   
 38.  $f(x) = x^2 + 2x$  and  $g(x) = x - 3$       39.  $f(x) = \sqrt{x-1}$  and  $g(x) = \frac{x+1}{2}$   
 40.  $f(x) = x^3 + 4x^2$  and  $g(x) = |x| - 1$       41.  $f(x) = -3x + 2$  and  $g(x) = x^2 + 2$

$$42. f(x) = x + 2 \text{ and } g(x) = \frac{x^2 + 3}{2} \qquad 43. f(x) = \sqrt{x-1} \text{ and } g(x) = x^2$$

Write each of the following functions as a composition of two functions. Answers will vary. See Example 7.

$$44. f(x) = \sqrt[3]{3x^2 - 1} \qquad 45. f(x) = \frac{2}{5x-1}$$

$$46. f(x) = |x-2| + 3 \qquad 47. f(x) = x + \sqrt{x+2} - 5$$

$$48. f(x) = |x^3 - 5x| + 7 \qquad 49. f(x) = \frac{\sqrt{x-3}}{x^2 - 6x + 9}$$

$$50. f(x) = \sqrt{2x^3 - 3} - 4 \qquad 51. f(x) = |x^2 + 3x| - 3$$

$$52. f(x) = \frac{3}{4x-2}$$

In each of the following exercises, use the information given to find  $g(x)$ .

$$53. f(x) = |x+3| \text{ and } (f+g)(x) = |x+3| + \sqrt{x+5}$$

$$54. f(x) = x \text{ and } (f \circ g)(x) = \frac{x+12}{-3}$$

$$55. f(x) = x^2 - 3 \text{ and } (f-g)(x) = x^3 + x^2 + 4$$

$$56. f(x) = x^2 \text{ and } (g \circ f)(x) = \sqrt{-x^2 + 5} + 4$$

### 🔑 APPLICATIONS

57. The volume of a right circular cylinder is given by the formula  $V = \pi r^2 h$ . If the height  $h$  is three times the radius  $r$ , show the volume  $V$  as a function of  $r$ .
58. The surface area  $S$  of a wind sock is given by the formula  $S = \pi r \sqrt{r^2 + h^2}$ , where  $r$  is the radius of the base of the wind sock and  $h$  is the height of the wind sock. As the wind sock is being knitted by an automated knitter, the height  $h$  increases with time  $t$  according to the formula  $h(t) = \frac{1}{4}t^2$ . Find the surface area  $S$  of the wind sock as a function of time  $t$  and radius  $r$ .

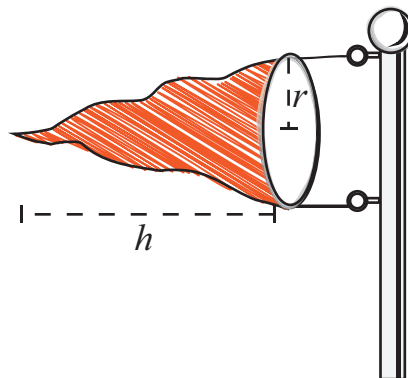

59. The volume  $V$  of the wind sock described in the previous exercise is given by the formula  $V = \frac{1}{3}\pi r^2 h$  where  $r$  is the radius of the wind sock and  $h$  is the height of the wind sock. If the height  $h$  increases with time  $t$  according to the formula  $h(t) = \frac{1}{4}t^2$ , find the volume  $V$  of the wind sock as a function of time  $t$  and radius  $r$ .
60. A widget factory produces  $n$  widgets in  $t$  hours of a single day. The number of widgets the factory produces is given by the formula  $n(t) = 10,000t - 25t^2$ ,  $0 \leq t \leq 9$ . The cost  $c$  in dollars of producing  $n$  widgets is given by the formula  $c(n) = 2040 + 1.74n$ . Find the cost  $c$  as a function of time  $t$ .

 **WRITING & THINKING**

61. Given two odd functions  $f$  and  $g$ , show that  $f \circ g$  is also odd. Verify this fact with the particular functions  $f(x) = \sqrt[3]{x}$  and  $g(x) = \frac{-x^3}{3x^2 - 9}$ . Recall that a function is odd if  $f(-x) = -f(x)$  for all  $x$  in the domain of  $f$ .
62. Given two even functions  $f$  and  $g$ , show that the product is also even. Verify this fact with the particular functions  $f(x) = 2x^4 - x^2$  and  $g(x) = \frac{1}{x^2}$ . Recall that a function is even if  $f(-x) = f(x)$  for all  $x$  in the domain of  $f$ .

As mentioned in Topic 4, a given complex number  $c$  is said to be in the Mandelbrot set if, for the function  $f(z) = z^2 + c$ , the sequence of iterates  $f(0), f^2(0), f^3(0), \dots$  stays close to the origin (which is the complex number  $0 + 0i$ ). It can be shown that if any single iterate falls more than 2 units in distance (magnitude) from the origin, then the remaining iterates will grow larger and larger in magnitude. In practice, computer programs that generate the Mandelbrot set calculate the iterates up to a predecided point in the sequence, such as  $f^{50}(0)$ , and if no iterate up to this point exceeds 2 in magnitude, the number  $c$  is admitted to the set. The magnitude of a complex number  $a + bi$  is the distance between the point  $(a, b)$  and the origin, so the formula for the magnitude of  $a + bi$  is  $\sqrt{a^2 + b^2}$ .

Use the above criterion to determine, without a calculator or computer, if the following complex numbers are in the Mandelbrot set or not.

63.  $c = 0$                       64.  $c = 1$                       65.  $c = i$                       66.  $c = -1$
67.  $c = 1 + i$                       68.  $c = -i$                       69.  $c = 1 - i$                       70.  $c = -1 - i$
71.  $c = 2$                       72.  $c = -2$

## 4.4 EXERCISES

### 💡 PRACTICE

Graph the inverse of each of the following relations, and state its domain and range. See Example 1.

- $R = \{(-4, 2), (3, 2), (0, -1), (3, -2)\}$
- $S = \{(-3, -3), (-1, -1), (0, 1), (4, 4)\}$
- $y = x^3$
- $y = |x| + 2$
- $x = |y|$
- $x = -\sqrt{y}$
- $y = \frac{1}{2}x - 3$
- $y = -x + 1$
- $y = \sqrt{x} + 2$
- $T = \{(4, 2), (3, -1), (-2, -1), (2, 4)\}$
- $x = y^2 - 2$
- $y = 2\sqrt{x}$

Determine if each of the following functions is a one-to-one function. If so, graph the inverse of the function and state its domain and range.

13.  $y = 2x + 3$

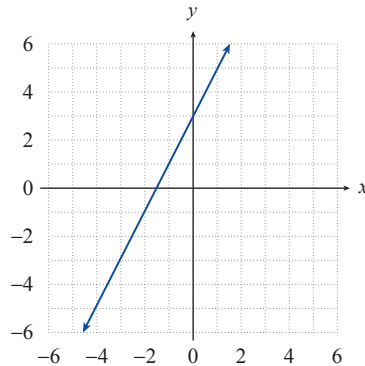

14.  $y = x^2 + 4x$

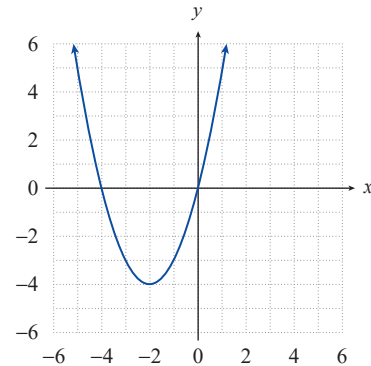

15.  $y = \frac{1}{x^2}$

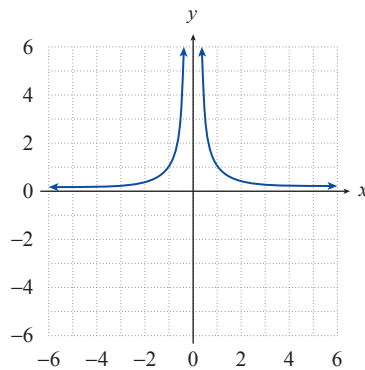

16.  $y = \frac{-3x - 3}{2}$

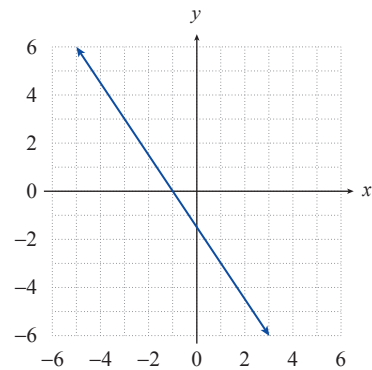

Determine if the following functions have inverse functions. If not, suggest a domain to restrict the function to so that it would have an inverse function (answers will vary). See Example 2.

17.  $f(x) = x^2 + 1$       18.  $g(x) = (x-2)^3 - 1$       19.  $h(x) = \sqrt{x+3}$   
 20.  $s(x) = \frac{1}{x^2}$       21.  $G(x) = 3x - 5$       22.  $F(x) = -x^2 + 5$   
 23.  $r(x) = -\sqrt{x^3}$       24.  $b(x) = \frac{1}{x}$       25.  $f(x) = x^2 - 4x$   
 26.  $m(x) = \frac{13x-2}{4}$       27.  $H(x) = |x-12|$       28.  $p(x) = 10 - x^2$

Find a formula for the inverse of each of the following functions. If necessary, first restrict the domain of the function. See Examples 3 and 4.

29.  $f(x) = x^{\frac{1}{3}} - 2$       30.  $g(x) = 4x - 3$       31.  $r(x) = \frac{x-1}{3x+2}$   
 32.  $s(x) = \frac{1-x}{1+x}$       33.  $F(x) = (x-5)^3 + 2$       34.  $G(x) = \sqrt[3]{3x-1}$   
 35.  $V(x) = \frac{x+5}{2}$       36.  $W(x) = \frac{1}{x}$       37.  $h(x) = x^{\frac{3}{5}} - 2$   
 38.  $A(x) = (x^3 + 1)^{\frac{1}{5}}$       39.  $J(x) = \frac{2}{1-3x}$       40.  $k(x) = \frac{x+4}{3-x}$   
 41.  $h(x) = x^7 + 6$       42.  $F(x) = \frac{3-x^5}{-9}$       43.  $r(x) = \sqrt[5]{2x}$   
 44.  $P(x) = (2+3x)^3$       45.  $f(x) = 3(2x)^{\frac{1}{3}}$       46.  $q(x) = (x-2)^2 + 2$   
 47.  $f(x) = (x-3)^2 + 2$       48.  $f(x) = |x+2| + 3$       49.  $f(x) = (x+1)^4 - 2$

In each of the following exercises, verify that  $f(f^{-1}(x)) = x$  and that  $f^{-1}(f(x)) = x$ . See Example 5.

50.  $f(x) = \frac{3x-1}{5}$  and  $f^{-1}(x) = \frac{5x+1}{3}$   
 51.  $f(x) = \sqrt[3]{x+2} - 1$  and  $f^{-1}(x) = (x+1)^3 - 2$   
 52.  $f(x) = \frac{2x+7}{x-1}$  and  $f^{-1}(x) = \frac{x+7}{x-2}$   
 53.  $f(x) = x^2, x \geq 0$  and  $f^{-1}(x) = \sqrt{x}$   
 54.  $f(x) = 2x - 3$  and  $f^{-1}(x) = \frac{x+3}{2}$

55.  $f(x) = \sqrt[3]{x+1}$  and  $f^{-1}(x) = x^3 - 1$

56.  $f(x) = \frac{1}{x}$  and  $f^{-1}(x) = \frac{1}{x}$

57.  $f(x) = \frac{x-5}{2x+3}$  and  $f^{-1}(x) = \frac{3x+5}{1-2x}$

58.  $f(x) = (x-2)^2, x \geq 2$  and  $f^{-1}(x) = \sqrt{x} + 2, x \geq 0$

59.  $f(x) = \frac{1}{1+x}$  and  $f^{-1}(x) = \frac{1-x}{x}$

Match the following functions with the graphs of the inverses of the functions.

60.  $f(x) = x^3$

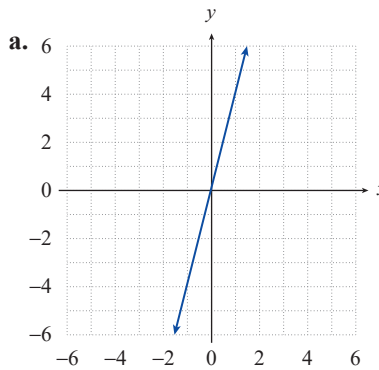

61.  $f(x) = x - 5$

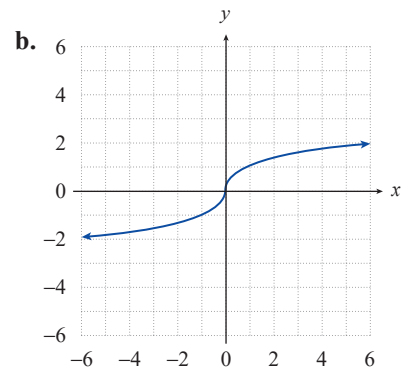

62.  $f(x) = \sqrt{x-4}$

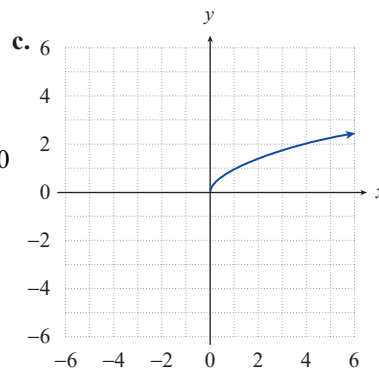

63.  $f(x) = x^2, x \geq 0$

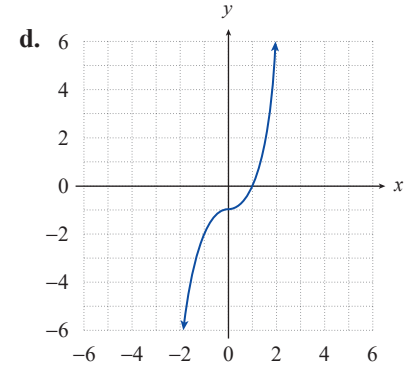

64.  $f(x) = \frac{x}{4}$

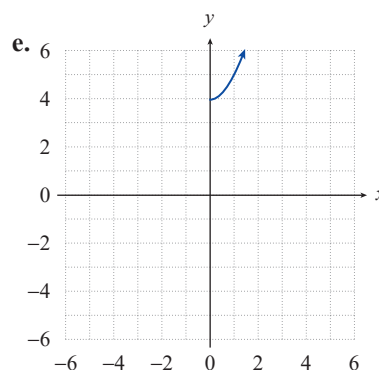

65.  $f(x) = \sqrt[3]{x+1}$

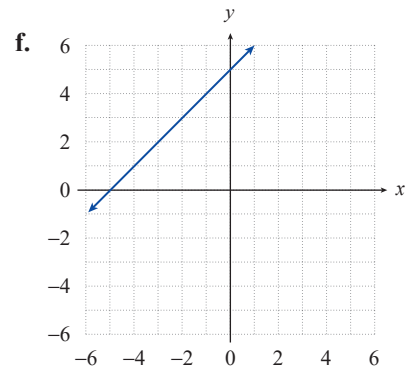

 APPLICATIONS

An inverse function can be used to encode and decode words and sentences by assigning each letter of the alphabet a numerical value ( $A = 1, B = 2, C = 3, \dots, Z = 26$ ).

Example: Use the function  $f(x) = x^2$  to encode the word PRECALCULUS. The encoded message would be 256 324 25 9 1 144 9 441 144 441 361. The word can then be decoded by using the inverse function  $f^{-1}(x) = \sqrt{x}$ . The inverse values are 16 18 5 3 1 12 3 21 12 21 19 which translates back to the word PRECALCULUS. Encode or decode the following words using the numerical values  $A = 1, B = 2, C = 3, \dots, Z = 26$ .

66. Encode the message SANDY SHOES using the function  $f(x) = 4x - 3$ .
67. Encode the message WILL IT RAIN TODAY using the function  $f(x) = 8x$ .
68. The following message was encoded using the function  $f(x) = 8x - 7$ . Decode the message.  
41 137 65 145 9 33 33 169 113 89 89 33 193 9 1 89 89 1 105 25 57  
113 137 145 33 145 57 113 33 145
69. The following message was encoded using the function  $f(x) = 5x + 1$ . Decode the message.  
91 26 66 26 66 11 26 91 126 76 106 91 96 106 71 11 61 76 16 56
70. The following message was encoded using the function  $f(x) = x^3$ . Decode the message.  
27 1 8000 27 512 1 12167 1 10648 125
71. The following message was encoded using the function  $f(x) = -3 - 5x$ . Decode the message.  
-13 -28 -8 -18 -43 -33 -108 -73 -48 -73 -103 -43 -28 -98 -108 -73

 TECHNOLOGY

A graphing utility can be used to verify the inverse of a function. Use a graphing utility to graph each of the following functions and its inverse in the same viewing window. Determine the domain and range of the inverse.

72.  $f(x) = \sqrt{x+5}$  and  $f^{-1}(x) = x^2 - 5$     73.  $f(x) = x^3 - 1$  and  $f^{-1}(x) = \sqrt[3]{x+1}$
74.  $f(x) = \frac{2x+1}{x-1}$  and  $f^{-1}(x) = \frac{x+1}{x-2}$     75.  $f(x) = \frac{4}{\sqrt{x}}$  and  $f^{-1}(x) = \frac{16}{x^2}$
76.  $f(x) = -\sqrt{x^2-16}, x \geq 4$  and  $f^{-1}(x) = \sqrt{x^2+16}$
77.  $f(x) = x^2 + 3, x \geq 0$  and  $f^{-1}(x) = \sqrt{x-3}$

We also again select a test point within each of the four intervals defined by the zeros, but instead of computing the exact value of  $p(x)$  at each test point, we simply determine its sign. For instance, using the test point  $x = -3$  in the interval  $(-\infty, -2)$ , we know that  $p(-3)$  is positive because  $(-3+2) < 0$ ,  $(-3-1)^2 > 0$ ,  $(-3-3) < 0$  and the product of a negative factor, a positive factor, and a negative factor is positive. In Figure 17, a representative test point for each interval is shown, followed by a string of “+” and “-” signs indicating the sign of each factor of  $p(x)$  at the test point. Finally, the sign of  $p(x)$  overall on the interval is shown.

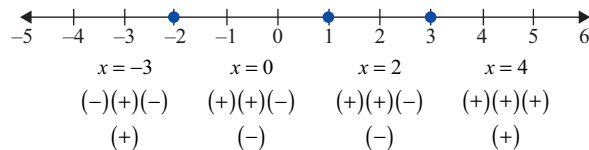

FIGURE 17

The last step of the method is to use the sign chart to identify the interval(s) on which  $p(x) \leq 0$ . Since the inequality is not strict and the two intervals on which  $p(x)$  is nonpositive overlap at  $x = 1$ , the solution is  $[-2, 3]$ .

## 5.1 EXERCISES

### PRACTICE

Verify that the given values of  $x$  solve the corresponding polynomial equations. See Example 1.

1.  $9x^2 - 4x = 2x^3 + 15$ ;  $x = -1$
2.  $x^2 - 4x = -13$ ;  $x = 2 - 3i$
3.  $x^2 + 13 = 4x$ ;  $x = 2 + 3i$
4.  $3x^3 + (5 - 3i)x^2 = (2 + 5i)x - 2i$ ;  $x = i$
5.  $9x^2 - 4x = 2x^3 + 15$ ;  $x = 3$
6.  $9x^2 - 4x = 2x^3 + 15$ ;  $x = \frac{5}{2}$
7.  $3x^3 + (5 - 3i)x^2 = (2 + 5i)x - 2i$ ;  $x = -2$
8.  $x^5 - 10x^4 - 80x^2 = 32 - 80x - 40x^3$ ;  $x = 2$
9.  $4x^5 - 8x^4 - 12x^3 = 16x^2 - 25x - 69$ ;  $x = 3$
10.  $x^2 - 4x - 12 = 0$ ;  $x = 6$
11.  $23x^7 - 12x^5 = 63x^4 - 3x^2$ ;  $x = 0$
12.  $x^2 + 74 = 10x$ ;  $x = 5 + 7i$
13.  $4x^2 + 32x + (8 + i)x^3 = -8$ ;  $x = 2i$
14.  $8x - 17 = x^2$ ;  $x = 4 - i$
15.  $(5 - 3i)x - 3x = 4 - 6i$ ;  $x = 2$
16.  $x^6 - x^5 + 7x^4 + x^3 - 9x = -1$ ;  $x = 1$
17.  $6x^7 - 3x^5 = 3x^4 - 6x^2$ ;  $x = -1$

Determine if the given values of  $x$  are solutions of the corresponding polynomial equations. See Example 1.

18.  $16x = x^3 + x^2 + 20$ ;  $x = -5$

19.  $x^4 - 13x^2 + 12 = -x^3 + x$ ;  $x = -1$

20.  $x^4 - 3x^3 - 10x^2 = 0$ ;  $x = 2$

21.  $4x^5 - 216x^2 = 36x^3 - 24x^4$ ;  $x = -6$

22.  $x^3 - 8ix + 30 = 15x + 2x^2 + 16i$ ;  $x = -i$

23.  $x^3 - 7x^2 + 4x - 28 = 0$ ;  $x = 2i$

Solve the following polynomial equations by factoring and/or using the quadratic formula, making sure to identify all the solutions. See Section 1.8 for review, if necessary.

24.  $x^3 - x^2 - 6x = 0$

25.  $x^2 - 2x + 5 = 0$

26.  $x^4 + x^2 - 2 = 0$

27.  $2x^2 + 5x = 3$

28.  $9x^2 = 6x - 1$

29.  $x^4 - 8x^2 + 15 = 0$

30.  $x^3 - x^2 = 72x$

31.  $x^2 + 5x = -\frac{25}{4}$

32.  $2x^2 + 5 = 11x$

33.  $x^4 - 8x^3 + 25x^2 = 0$

34.  $x^4 - 13x^2 + 36 = 0$

35.  $x^4 + 7x^2 = 8$

For each of the following polynomials, determine the degree and the leading coefficient; then determine the behavior of the graph as  $x \rightarrow \pm\infty$ .

36.  $p(x) = 2x^4 - 3x^3 - 6x^2 - x - 23$

37.  $j(x) = 4x^7 + 5x^5 + 12$

38.  $r(x) = (3x + 5)(x - 2)(2x - 1)(4x - 7)$

39.  $h(x) = -6x^5 + 2x^3 - 7x$

40.  $g(x) = (x - 5)^3(2x + 1)(-x - 1)$

41.  $f(x) = -2(x + 4)(x - 4)(x^2)$

For each of the following polynomial functions, determine the behavior of its graph as  $x \rightarrow \pm\infty$  and identify the  $x$ - and  $y$ -intercepts. Use this information to sketch the graph of each polynomial. See Example 2.

42.  $f(x) = (x - 3)(x + 2)(x + 4)$

43.  $g(x) = (3 - x)(x + 2)(x + 4)$

44.  $f(x) = (x - 2)^2(x + 5)$

45.  $h(x) = -(x + 2)^3$

46.  $r(x) = x^2 - 2x - 3$

47.  $s(x) = x^3 + 3x^2 + 2x$

48.  $f(x) = -(x - 2)(x + 1)^2(x + 3)$

49.  $g(x) = (x - 3)^5$

Find the polynomial of lowest possible degree that corresponds to the given graph. See Example 3.

50.

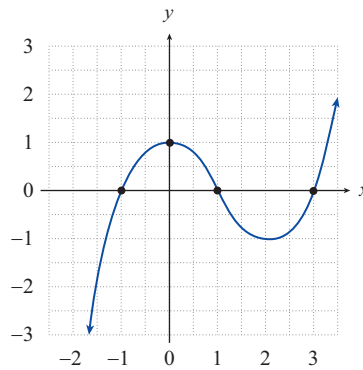

51.

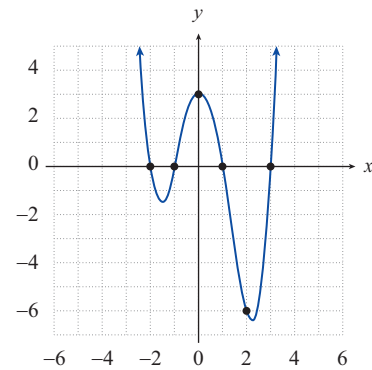

52.

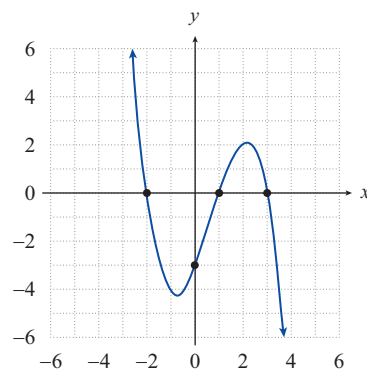

53.

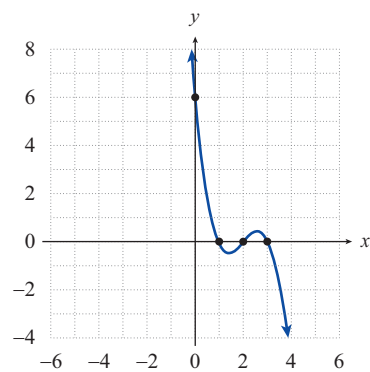

In Exercises 54 through 59, use the behavior as  $x \rightarrow \pm\infty$  and the intercepts to match each polynomial with its graph.

54.  $g(x) = (x+1)^2(x-3)^2$

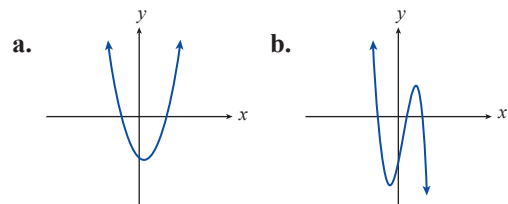

55.  $h(x) = 1 - (x+2)^2$

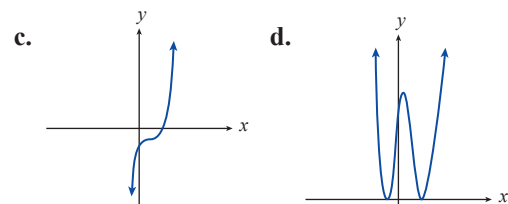

56.  $f(x) = (x-1)(x+2)(3-x)$

57.  $r(x) = x^2 - x - 6$

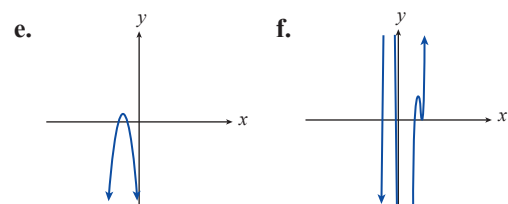

58.  $s(x) = (x-1)^3 - 2$

59.  $f(x) = (x-3)^2(4x+1)(x+2)(x-2)$

Match each of the following functions to the appropriate description.

60.  $z(x) = (x-1)(x+2)(4-x)$     a. cubic curve increasing as  $x \rightarrow \infty$ , has  $x$ -intercepts of 0,  $-1$ , and  $-2$ , and crosses the  $y$ -axis at 0.
61.  $r(x) = x^2 - 6x - 7$     b. parabola that opens up, has  $x$ -intercepts at 6 and  $-1$ , crosses the  $y$ -axis at  $-6$ .
62.  $s(x) = x^3 + 3x^2 + 2x$     c. cubic curve increasing as  $x \rightarrow \infty$ , has  $x$ -intercepts of 0,  $-1$ , and  $-4$ , and crosses the  $y$ -axis at 0.
63.  $g(x) = (x-1)(x+4)(3-x)$     d. parabola that opens up, has  $x$ -intercepts at 7 and  $-1$ , crosses the  $y$ -axis at  $-7$ .
64.  $s(x) = x^3 + 5x^2 + 4x$     e. cubic curve decreasing as  $x \rightarrow \infty$ , has  $x$ -intercepts at 1, 4, and  $-2$ , crosses the  $y$ -axis at  $-8$ .
65.  $s(x) = x^2 - 5x - 6$     f. cubic curve decreasing as  $x \rightarrow \infty$ , has  $x$ -intercepts of 1, 3, and  $-4$ , and crosses the  $y$ -axis at  $-12$ .

Solve the following polynomial inequalities. See Examples 5 and 6.

66.  $x^2 - x - 6 \leq 0$     67.  $x^2 > x + 6$
68.  $(x+2)^2(x-1)^2 > 0$     69.  $x^3 + 3x^2 + 2x < 0$
70.  $(x-2)(x+1)(x+3) \geq 0$     71.  $(x-1)(x+2)(3-x) \leq 0$
72.  $-x^3 - x^2 + 30x > 0$     73.  $(x^2 - 1)(x-4)(x+5) \leq 0$
74.  $x^4 + x^2 > 0$     75.  $4x^2 < 6x + 4$
76.  $x^2(x+4)(x-3) > 0$     77.  $(x-3)(x+4)(2-x) > 0$

### APPLICATIONS

For Exercises 78–83, use the fact that profit is equal to revenue minus cost.

78. A small start-up skateboard company projects that the cost per month of manufacturing  $x$  skateboards will be  $C(x) = 10x + 300$ , and the revenue per month from selling  $x$  skateboards will be  $r(x) = -x^2 + 50x$ . For what value(s) of  $x$  will the company break even or make a profit?
79. A manufacturer has determined that the revenue from the sale of  $x$  cordless telephones is given by  $r(x) = -x^2 + 15x$ . The cost of producing  $x$  telephones is  $C(x) = 135 - 17x$ . For what value(s) of  $x$  will the company break even or make a profit?

80. The revenue from the sale of  $x$  fire extinguishers is estimated to be  $r(x) = 9 - x^2$ . The total cost of producing  $x$  fire extinguishers is  $C(x) = 209 - 33x$ . For what value(s) of  $x$  will the company break even or make a profit?
81. A manufacturer has determined that the cost and revenue of producing and selling  $x$  telescopes are  $C(x) = 253 - 7x$  and  $r(x) = 27x - x^2$ , respectively. For what value(s) of  $x$  will the company break even or make a profit?
82. A company that produces and sells compact refrigerators has found that the revenue from the sale of  $x$  compact refrigerators is  $r(x) = -x^2 + 30x - 370$ . The cost function is given by  $C(x) = 6 - 25x$ . For what value(s) of  $x$  will the company break even or make a profit?
83. An electronics company is deciding whether or not to begin producing phones. The company must determine if a profit can be made on the phones. The profit function is modeled by the equation  $P(x) = x + 0.27x^2 - 0.0015x^3 - 300$ , where  $x$  is the number of phones produced in hundreds. Given this equation, how many phones must the company produce to make a profit?
84. The population of sea lions on an island is represented by the function  $L(m) = 110m^2 - 0.35m^4 + 750$ , where  $m$  is the number of months the sea lions have been observed on the island. Given this information, how many more months will there be sea lions on the island?
85. The population of mosquitoes in a city in Florida is modeled by the function  $M(w) = 200w^2 - 0.01w^4 + 1200$ , where  $w$  is the number of weeks since the town began spraying for mosquitoes. How many weeks will it take for all the mosquitoes to die?

But does  $p(x) \rightarrow -\infty$  as  $x \rightarrow \infty$ ? No, if we multiply out, the leading term of this polynomial would be  $x^3$ , which has a positive leading coefficient. To fix this, we multiply the entire polynomial by  $-1$ .

$$\begin{aligned} p(x) &= -(x+3)(x-2)(x-5) \\ &= -x^3 + 4x^2 + 11x - 30 \end{aligned}$$

- b. Once again,  $p(x)$  is a product of linear factors, identified by the required zeros.

$$p(x) = (x+5)(x+2)(x-1)(x-3)$$

Our second condition is that the  $y$ -intercept must be  $(0,15)$ . If we substitute  $x = 0$ , we see that  $p(0) = (5)(2)(-1)(-3) = 30$ , so the  $y$ -intercept is  $(0,30)$ . To fix this, we might try subtracting 15 from the polynomial.

$$p(x) \stackrel{?}{=} (x+5)(x+2)(x-1)(x-3) - 15$$

But, we can not do this because it causes  $-5$ ,  $-2$ ,  $1$  and  $3$  to no longer be zeros! Instead, we multiply  $p(x)$  by  $\frac{1}{2}$ .

$$\begin{aligned} p(x) &= \frac{1}{2}(x+5)(x+2)(x-1)(x-3) \\ &= \frac{1}{2}x^4 + \frac{3}{2}x^3 - \frac{15}{2}x^2 - \frac{19}{2}x + 15 \end{aligned}$$

## 5.2 EXERCISES

### PRACTICE

Use polynomial long division to rewrite each of the following fractions in the form  $q(x) + \frac{r(x)}{d(x)}$ , where  $d(x)$  is the denominator of the original fraction,  $q(x)$  is the quotient, and  $r(x)$  is the remainder. See Examples 1 through 3.

1.  $\frac{6x^4 - 2x^3 + 8x^2 + 3x + 1}{2x^2 + 2}$

2.  $\frac{5x^2 + 9x - 6}{x + 2}$

3.  $\frac{x^3 - 6x^2 + 12x - 10}{x^2 - 4x + 4}$

4.  $\frac{7x^5 - x^4 + 2x^3 - x^2}{x^2 + 1}$

5.  $\frac{4x^3 - 6x^2 + x - 7}{x + 2}$

6.  $\frac{x^3 + 2x^2 - 4x - 8}{x - 3}$

7.  $\frac{3x^5 + 18x^4 - 7x^3 + 9x^2 + 4x}{3x^2 - 1}$

8.  $\frac{9x^5 - 10x^4 + 18x^3 - 28x^2 + x + 3}{9x^2 - x - 1}$

9.  $\frac{2x^5 - 5x^4 + 7x^3 - 10x^2 + 7x - 5}{x^2 - x + 1}$

10.  $\frac{14x^5 - 2x^4 + 27x^3 - 3x^2 + 9x}{2x^3 + 3x}$

11. 
$$\frac{x^4 + x^2 - 20x - 8}{x - 3}$$

13. 
$$\frac{9x^3 + 2x}{3x - 5}$$

15. 
$$\frac{2x^2 + x - 8}{x + 3}$$

17. 
$$\frac{2x^3 - 3ix^2 + 11x + (1 - 5i)}{2x - i}$$

19. 
$$\frac{3x^3 + ix^2 + 9x + 3i}{3x + i}$$

12. 
$$\frac{2x^5 - 3x^2 + 1}{x^2 + 1}$$

14. 
$$\frac{-4x^5 + 8x^3 - 2}{2x^3 + x}$$

16. 
$$\frac{5x^5 + x^4 - 13x^3 - 2x^2 + 6x}{x^3 - 2x}$$

18. 
$$\frac{9x^3 - (18 + 9i)x^2 + x + (-2 - i)}{x - 2 - i}$$

20. 
$$\frac{35x^4 + (14 - 10i)x^3 - (7 + 4i)x^2 + 2ix}{7x - 2i}$$

Use synthetic division to determine if the given value for  $c$  is a zero of the corresponding polynomial. If not, determine  $p(c)$ . See Example 4.

21.  $p(x) = 32x^5 - 80x^4 + 80x^3 - 40x^2 + 10x + 2; c = 1$

22.  $p(x) = 32x^5 - 80x^4 + 80x^3 - 40x^2 + 10x + 2; c = \frac{1}{2}$

23.  $p(x) = 12x^4 - 7x^3 - 32x^2 - 7x + 6; c = 2$

24.  $p(x) = 12x^4 - 7x^3 - 32x^2 - 7x + 6; c = 1$

25.  $p(x) = 12x^4 - 7x^3 - 32x^2 - 7x + 6; c = \frac{1}{3}$

26.  $p(x) = 2x^2 - (3 - 5i)x + (3 - 9i); c = -2$

27.  $p(x) = 8x^4 - 2x + 6; c = 1$

28.  $p(x) = x^4 - 1; c = 1$

29.  $p(x) = x^5 + 32; c = -2$

30.  $p(x) = 3x^5 + 9x^4 + 2x^2 + 5x - 3; c = -3$

31.  $p(x) = 2x^2 - (3 - 5i)x + (3 - 9i); c = -3i$

32.  $p(x) = x^2 - 6x + 13; c = 2$

33.  $p(x) = x^2 - 6x + 13; c = 3 - 2i$

34.  $p(x) = 3x^3 - 13x^2 - 28x - 12; c = -2$

35.  $p(x) = 3x^3 - 13x^2 - 28x - 12; c = 6$

36.  $p(x) = 2x^3 - 8x^2 - 23x + 63; c = 2$

37.  $p(x) = 2x^3 - 8x^2 - 23x + 63; c = 5$

38.  $p(x) = x^4 - 3x^3 - 3x^2 + 11x - 6; c = 1$

39.  $p(x) = x^4 - 3x^3 - 3x^2 + 11x - 6; c = -2$

40.  $p(x) = x^4 - 3x^3 - 3x^2 + 11x - 6; c = 3$

Use synthetic division to rewrite each of the following fractions in the form  $q(x) + \frac{r(x)}{d(x)}$ , where  $d(x)$  is the denominator of the original fraction,  $q(x)$  is the quotient, and  $r(x)$  is the remainder. See Example 5.

41. 
$$\frac{x^3 + x^2 - 18x + 9}{x + 5}$$

42. 
$$\frac{-2x^5 + 4x^4 + 3x^3 - 7x^2 + 3x - 2}{x - 2}$$

43. 
$$\frac{x^8 + x^7 - 3x^3 - 3x^2 + 3}{x + 1}$$

44. 
$$\frac{x^8 - 5x^7 - 3x^3 + 15x^2 - 2}{x - 5}$$

45. 
$$\frac{4x^3 - (16 + 4i)x^2 + (14 + 4i)x + (-6 - 2i)}{x - 3 - i}$$

46. 
$$\frac{x^6 - 2x^5 + 2x^4 + 4x^2 - 8x + 8}{x - 1 + i}$$

47. 
$$\frac{x^5 - 3x^4 + x^3 - 5x^2 + 18}{x - 2}$$

48. 
$$\frac{x^5 - 3x^4 + x^3 - 5x^2 + 18}{x - 3}$$

49. 
$$\frac{x^4 + (i - 1)x^3 + (1 - i)x^2 + ix}{x + i}$$

50. 
$$\frac{x^6 + 8x^5 + x^3 + 8x^2 - 14x - 112}{x + 8}$$

51. 
$$\frac{2x^3 - 10ix^2 + 5x + (8 - 3i)}{x - 3i}$$

52. 
$$\frac{4x^5 - 6x^4 + 10x^3 - 4x^2 - 4x}{x - 1}$$

### WRITING & THINKING

Construct a polynomial function with the stated properties. See Example 6.

53. Second-degree, zeros of  $-4$  and  $3$ , and goes to  $-\infty$  as  $x \rightarrow -\infty$ .
54. Third-degree, zeros of  $-2$ ,  $1$ , and  $3$ , and a  $y$ -intercept of  $-12$ .
55. Second-degree, zeros of  $2 - 3i$  and  $2 + 3i$ , and a  $y$ -intercept of  $-13$ .
56. Third-degree, zeros of  $1 - i$ ,  $2 + i$ , and  $-1$ , and a leading coefficient of  $-2$ .
57. Fourth-degree and a single  $x$ -intercept of  $3$ .
58. Second-degree, zeros of  $-\frac{3}{4}$  and  $2$ , and a  $y$ -intercept of  $6$ .
59. Fourth-degree, zeros of  $-3$ ,  $-2$ , and  $1$ , and a  $y$ -intercept of  $18$ .
60. Third-degree, zeros of  $1$ ,  $2$ , and  $3$ , and passes through the point  $(4, 12)$ .

### APPLICATIONS

61. A box company makes a variety of boxes, all with volume given by the formula  $x^3 + 10x^2 + 31x + 30$ . If the height is given by  $x + 3$ , what is the formula for the surface area of the base?

## 5.3 EXERCISES

### PRACTICE

List all of the potential rational zeros of the following polynomials. Then use polynomial division and the quadratic formula, if necessary, to identify the actual zeros. See Example 1.

- |   |  |
|---|--|
| 1. $f(x) = 3x^3 + 5x^2 - 26x + 8$         | 2. $g(x) = -2x^3 + 11x^2 + x - 30$       |
| 3. $p(x) = x^4 - 5x^3 + 10x^2 - 20x + 24$ | 4. $h(x) = x^3 - 3x^2 + 9x + 13$         |
| 5. $q(x) = x^3 - 10x^2 + 23x - 14$        | 6. $r(x) = x^4 + x^3 + 23x^2 + 25x - 50$ |
| 7. $s(x) = 2x^3 - 9x^2 + 4x + 15$         | 8. $t(x) = x^3 - 6x^2 + 13x - 20$        |
| 9. $j(x) = 3x^4 - 3$                      | 10. $k(x) = x^4 - 10x^2 + 24$            |
| 11. $m(x) = x^3 + 11x^2 - x - 11$         | 12. $g(x) = x^3 - 6x^2 - 5x + 30$        |

Using the Rational Zero Theorem or your answers to the preceding problems, solve the following polynomial equations.

- |                                     |                              |
|-------------------------------------|------------------------------|
| 13. $x^4 + x - 2 = -2x^4 + x + 1$   | 14. $x^4 + 10 = 10x^2 - 14$  |
| 15. $x^3 - 3x^2 + 9x + 13 = 0$      | 16. $3x^3 + 5x^2 = 26x - 8$  |
| 17. $x^4 + 10x^2 - 20x = 5x^3 - 24$ | 18. $-2x^3 + 11x^2 + x = 30$ |
| 19. $2x^3 - 12x^2 + 26x = 40$       | 20. $2x^3 + 9x^2 + 4x = 15$  |
| 21. $x^4 + x^3 + 23x^2 = 50 - 25x$  | 22. $x^3 + 23x = 10x^2 + 14$ |
| 23. $x^3 + 11x^2 = 11 + x$          | 24. $-6x^2 + x^3 = 5x - 30$  |

Use Descartes' Rule of Signs to determine the possible numbers of positive and negative real zeros of each of the following polynomials. See Example 2.

- |   |  |
|---|--|
| 25. $f(x) = x^3 + 8x^2 + 17x + 10$            | 26. $g(x) = x^3 + 2x^2 - 5x - 6$             |
| 27. $f(x) = x^3 - 6x^2 + 3x + 10$             | 28. $g(x) = x^3 + 6x^2 + 11x + 6$            |
| 29. $f(x) = x^4 - 5x^3 - 2x^2 + 40x - 48$     | 30. $g(x) = x^3 + 3x^2 + 3x + 9$             |
| 31. $f(x) = x^4 - 25$                         | 32. $g(x) = x^4 - 7x^3 + 5x^2 + 31x - 30$    |
| 33. $f(x) = 5x^5 - x^4 + 2x^3 + x - 9$        | 34. $g(x) = -6x^7 - x^5 - 7x^3 - 2x$         |
| 35. $f(x) = -5x^{11} - 14x^9 - 10x^7 - 15x^5$ | 36. $g(x) = 2x^4 + 7x^3 + 28x^2 + 112x - 64$ |

Use synthetic division to identify upper and lower bounds of the real zeros of the following polynomials. See Example 3.

37.  $f(x) = x^3 + 4x^2 + x - 4$

38.  $f(x) = 2x^3 - 3x^2 - 8x - 3$

39.  $f(x) = x^3 - 6x^2 + 3x + 10$

40.  $g(x) = x^3 + 6x^2 + 11x + 6$

41.  $f(x) = x^4 - 5x^3 - 2x^2 + 40x - 48$

42.  $g(x) = x^3 + 3x^2 + 3x + 9$

43.  $f(x) = x^4 - 25$

44.  $g(x) = x^4 - 7x^3 + 5x^2 + 31x - 30$

45.  $f(x) = 2x^3 - 7x^2 - 28x - 12$

46.  $g(x) = x^5 + x^4 - 9x^3 - x^2 + 20x - 12$

Using your answers to the preceding problems, polynomial division, and the quadratic formula, if necessary, find all of the zeros of the following polynomials.

47.  $f(x) = x^3 + 4x^2 - x - 4$

48.  $f(x) = 2x^3 - 3x^2 - 8x - 3$

49.  $f(x) = x^3 - 6x^2 + 3x + 10$

50.  $g(x) = x^3 + 6x^2 + 11x + 6$

51.  $f(x) = x^4 - 5x^3 - 2x^2 + 40x - 48$

52.  $g(x) = x^3 + 3x^2 + 3x + 9$

53.  $f(x) = x^4 - 25$

54.  $g(x) = x^4 - 7x^3 + 5x^2 + 31x - 30$

55.  $f(x) = 2x^3 - 7x^2 - 28x - 12$

56.  $g(x) = x^5 + x^4 - 9x^3 - x^2 + 20x - 12$

Use the Intermediate Value Theorem to show that each of the following polynomials has a real zero between the indicated values. See Example 5.

57.  $f(x) = 5x^3 - 4x^2 - 31x - 6$ ;  $-3$  and  $-1$

58.  $f(x) = x^4 - 9x^2 - 14$ ;  $1$  and  $4$

59.  $f(x) = x^4 + 2x^3 - 10x^2 - 14x + 21$ ;  $2$  and  $3$

60.  $f(x) = -x^3 + 2x^2 + 13x - 26$ ;  $-4$  and  $-3$

Show that each of the following equations must have a solution between the indicated real numbers.

61.  $14x + 10x^2 = x^4 + 2x^3 + 21$ ;  $2$  and  $3$

62.  $x^3 - 2x^2 = 13(x - 2)$ ;  $-4$  and  $-3$

Using any of the methods discussed in this section as guides, find all of the real zeros of the following functions.

63.  $f(x) = 3x^3 - 18x^2 + 9x + 30$

64.  $f(x) = -4x^3 - 19x^2 + 29x - 6$

65.  $f(x) = 3x^5 + 7x^4 + 12x^3 + 28x^2 - 15x - 35$

66.  $f(x) = 2x^4 + 5x^3 - 9x^2 - 15x + 9$

67.  $f(x) = -15x^4 + 44x^3 + 15x^2 - 72x - 28$

68.  $f(x) = 2x^4 + 13x^3 - 23x^2 - 32x + 20$

69.  $f(x) = 3x^4 + 7x^3 - 25x^2 - 63x - 18$

70.  $f(x) = x^5 + 7x^4 + 5x^3 - 43x^2 - 42x + 72$

71.  $f(x) = 2x^5 - 3x^4 - 47x^3 + 103x^2 + 45x - 100$

72.  $f(x) = x^6 - 125x^4 + 4804x^2 - 57,600$

Using any of the methods discussed in this section as guides, solve the following equations.

73.  $x^3 + 6x^2 + 11x = -6$

74.  $x^3 - 7x = 6(x^2 - 10)$

75.  $x^3 + 9x^2 = 2x + 18$

76.  $6x^3 + 14 = 41x^2 + 9x$

77.  $4x^3 = 18x^2 + 106x + 48$

78.  $3x^3 + 15x^2 - 6x = 72$

79.  $8x^4 + 24 + 8x = 2x^3 + 38x^2$

80.  $x^4 + 7x^2 = 3x^3 + 21x$

81.  $6x^6 - 10x^5 - 9x^4 + 27x^3 = 20x^2 + 18x - 30$

82.  $4x^5 - 5x^4 + 20x^2 = 6x^3 + 25x + 30$

### WRITING & THINKING

83. Create a proof of the Rational Zero Theorem by following the suggested steps.

a. Assuming  $\frac{p}{q}$  is a zero of the polynomial  $f(x) = a_n x^n + a_{n-1} x^{n-1} + \cdots + a_1 x + a_0$ , show that the equation  $a_n \left(\frac{p}{q}\right)^n + a_{n-1} \left(\frac{p}{q}\right)^{n-1} + \cdots + a_1 \left(\frac{p}{q}\right) + a_0 = 0$  can be written in the form  $a_n p^n + a_{n-1} p^{n-1} q + \cdots + a_1 p q^{n-1} = -a_0 q^n$ .

b. It can be assumed that  $\frac{p}{q}$  is written in lowest terms (that is, the greatest common divisor of  $p$  and  $q$  is 1). By examining the left-hand side of the last equation above, show that  $p$  must be a divisor of the right-hand side, and hence a factor of  $a_0$ .

c. By rearranging the equation so that all terms with a factor of  $q$  are on one side, use a similar argument to show that  $q$  must be a factor of  $a_n$ .

- The observation that the graph of  $p$  crosses the  $y$ -axis at the easily computed point  $(0, p(0))$ .
- The technique of polynomial long division, useful in dividing one polynomial by another of the same or smaller degree.
- The technique of synthetic division, a shortcut that applies when dividing a polynomial by a polynomial of the form  $x - c$ . Recall that the remainder of this division is the value  $p(c)$ .
- The Rational Zero Theorem, which provides a list of potential rational zeros for polynomials with integer coefficients.
- Descartes' Rule of Signs, which provides guidance on the number of positive and negative real zeros that a real-coefficient polynomial might have.
- The Upper and Lower Bounds rule, which indicates an interval in which to search for all the zeros of a real-coefficient polynomial.
- The Intermediate Value Theorem, which can be used to “home in” on a real zero of a given polynomial.

As you solve various polynomial problems, try to keep the big picture in mind. Often, it is useful to literally keep a picture, namely the graph of the polynomial, in mind even if the problem does not specifically involve graphing.

## 5.4 EXERCISES

Throughout these exercises, a graphing utility may be helpful in identifying zeros and in checking your graphing, if permitted by your instructor.

### PRACTICE

Sketch the graph of each factored polynomial. See Example 1.

- |                                 |                              |
|---------------------------------|------------------------------|
| 1. $f(x) = (x+1)^4(x-2)^3(x-1)$ | 2. $g(x) = -x^3(x-1)(x+2)^2$ |
| 3. $f(x) = -x(x+2)(x-1)^2$      | 4. $g(x) = (x+2)(x-1)^3$     |
| 5. $f(x) = (x-1)^4(x-2)(x-3)$   | 6. $g(x) = (x+1)^2(x-2)^3$   |
| 7. $f(x) = (x-4)(x+2)^2(x-3)^3$ | 8. $g(x) = (x+3)(x-1)^5$     |

Use all available methods to factor each of the following polynomials completely, and then sketch the graph of each one. See Example 1.

- |   |                                    |
|---|------------------------------------|
| 9. $f(x) = x^5 + 4x^4 + x^3 - 10x^2 - 4x + 8$ | 10. $p(x) = 2x^3 - x^2 - 8x - 5$   |
| 11. $s(x) = -x^4 + 2x^3 + 8x^2 - 10x - 15$    | 12. $f(x) = -x^3 + 6x^2 - 12x + 8$ |

13.  $H(x) = x^4 - x^3 - 5x^2 + 3x + 6$

14.  $h(x) = x^5 - 11x^4 + 46x^3 - 90x^2 + 81x - 27$

15.  $f(x) = 2x^3 + 11x^2 + 20x + 12$

16.  $g(x) = x^4 + 3x^3 - 5x^2 - 21x - 14$

Use all available methods to solve each polynomial equation.

17.  $x^5 + 4x^4 + x^3 = 10x^2 + 4x - 8$

18.  $x^4 + 15 = 2x^3 + 8x^2 - 10x$

19.  $x^4 + x^3 + 3x^2 + 5x - 10 = 0$

20.  $x^3 - 9x^2 = 30 - 28x$

21.  $x^5 + x^4 - x^3 + 7x^2 - 20x + 12 = 0$

22.  $2x^4 - 5x^3 - 2x^2 + 15x = 0$

23.  $x^5 + 15x^3 + 16 = x^4 + 15x^2 + 16x$

24.  $x^3 - 5 = 5x^2 - 9x$

Use all available methods (in particular, the Conjugate Roots Theorem, if applicable) to factor each of the following polynomials completely, making use of the given zero if one is given. See Example 2.

25.  $f(x) = x^4 - 9x^3 + 27x^2 - 15x - 52$ ;  $3 - 2i$  is a zero.

26.  $g(x) = x^3 - (1 - i)x^2 - (8 - i)x + (12 - 6i)$ ;  $2 - i$  is a zero.

27.  $f(x) = x^3 - (2 + 3i)x^2 - (1 - 3i)x + (2 + 6i)$ ;  $2$  is a zero.

28.  $p(x) = x^4 - 2x^3 + 14x^2 - 8x + 40$ ;  $2i$  is a zero.

29.  $n(x) = x^4 - 4x^3 + 6x^2 + 28x - 91$ ;  $2 + 3i$  is a zero.

30.  $G(x) = x^4 - 14x^3 + 98x^2 - 686x + 2401$ ;  $7i$  is a zero.

31.  $f(x) = x^4 - 3x^3 + 5x^2 - x - 10$

32.  $g(x) = x^6 - 8x^5 + 25x^4 - 40x^3 + 40x^2 - 32x + 16$

33.  $r(x) = x^4 + 7x^3 - 41x^2 + 33x$

34.  $d(x) = x^5 - x^4 - 18x^3 + 18x^2 + 81x - 81$

35.  $P(x) = x^3 - 6x^2 + 28x - 40$

36.  $g(x) = x^6 - x^4 - 16x^2 + 16$

 WRITING & THINKING

Construct polynomial functions with the stated properties. See Example 3.

37. Third-degree, only real coefficients,  $-1$  and  $5+i$  are two of the zeros,  $y$ -intercept is  $-52$ .
38. Fourth-degree, only real coefficients,  $\sqrt{7}$  and  $i\sqrt{5}$  are two of the zeros,  $y$ -intercept is  $-35$ .
39. Fifth-degree,  $1$  is a zero of multiplicity  $3$ ,  $-2$  is the only other zero, leading coefficient is  $2$ .
40. Fifth-degree, only real coefficients,  $0$  is the only real zero,  $1+i$  is a zero of multiplicity  $1$ , leading coefficient is  $1$ .
41. Fourth-degree, only real coefficients,  $x$ -intercepts are  $0$  and  $6$ ,  $-2i$  is a zero, leading coefficient is  $3$ .
42. Fifth-degree,  $-2$  is a zero of multiplicity  $2$ , another integer is a zero of multiplicity  $3$ ,  $y$ -intercept is  $108$ , leading coefficient is  $1$ .
43. Third-degree, only real coefficients,  $-4$  and  $3+i$  are two of the zeros,  $y$ -intercept is  $-40$ .
44. Fifth-degree,  $1$  is a zero of multiplicity  $4$ ,  $-2$  is the only other zero, leading coefficient is  $4$ .
45. Third-degree, only real coefficients,  $-4$  and  $4+i$  are two of the zeros,  $y$ -intercept is  $-68$ .
46. Assume  $f(x)$  is an  $n^{\text{th}}$ -degree polynomial with real coefficients. Explain why the following statement is true: If  $n$  is even, the number of turning points is odd and if  $n$  is odd, the number of turning points is even.

 APPLICATIONS

47. An open-top box is to be constructed from a  $10$  inch by  $18$  inch sheet of tin by cutting out squares from each corner as shown and then folding up the sides. Let  $V(x)$  denote the volume of the resulting box.
  - a. Write  $V(x)$  as a product of linear factors.
  - b. For which values of  $x$  is  $V(x) = 0$ ?
  - c. Which answers from part b. are physically possible?

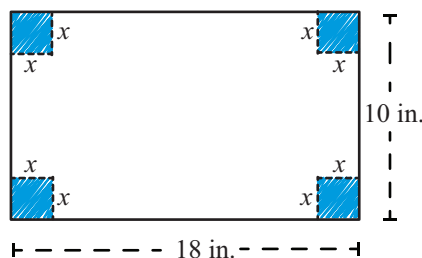

48. An open-top box is to be constructed from a 10 inch by 15 inch sheet of tin by cutting out squares from each corner and then folding up the sides. Let  $V(x)$  denote the volume of the resulting box.
- Write  $V(x)$  as a product of linear factors.
  - For which values of  $x$  is  $V(x) = 0$ ?
  - Which of your answers from part b. are physically possible?
49. An open-top box is to be constructed from a 9 inch by 17 inch sheet of tin by cutting out squares from each corner and then folding up the sides. Let  $V(x)$  denote the volume of the resulting box.
- Write  $V(x)$  as a product of linear factors.
  - For which values of  $x$  is  $V(x) = 0$ ?
  - Which of your answers from part b. are physically possible?

The final step is to evaluate which intervals satisfy each inequality. The solution to the first inequality is the union of the two intervals where  $f$  is positive.

$$(-\infty, -3) \cup (-2, \infty)$$

For the second inequality, we have to decide which endpoints to include. We include  $x = -3$ , since this is a zero of the rational function, but we do not include  $x = -2$ , since the value is not in the domain of  $f$ . Thus, the solution to the second inequality is

$$(-\infty, -3] \cup (-2, \infty).$$

## 5.5 EXERCISES

### PRACTICE

Find equations for the vertical asymptotes, if any, for each of the following rational functions. See Example 1.

1.  $f(x) = \frac{5}{x-1}$

2.  $f(x) = \frac{x^2+3}{x+3}$

3.  $f(x) = \frac{x^2-4}{x+2}$

4.  $f(x) = \frac{-3x+5}{x-2}$

5.  $f(x) = \frac{3x^2+1}{x-2}$

6.  $f(x) = \frac{x^2+2x}{x+1}$

7.  $f(x) = \frac{x^2-4}{2x-x^2}$

8.  $f(x) = \frac{x+2}{x^2-9}$

9.  $f(x) = \frac{x^2-2x-3}{2x^2-5x-3}$

10.  $f(x) = \frac{2x^2+2x-4}{x^2+2x+1}$

11.  $f(x) = \frac{x^3-27}{x^2+5}$

12.  $f(x) = \frac{x^2+5}{x^3-27}$

13.  $f(x) = \frac{x^2-1}{x^2-8x+7}$

14.  $f(x) = \frac{2x^2+7x-14}{2x^2+7x-15}$

15.  $f(x) = \frac{x^3-6x^2+11x-6}{x^3+8}$

16.  $f(x) = \frac{x^2-2x-15}{x-5}$

17.  $f(x) = \frac{x^2-16}{x^2-4}$

18.  $f(x) = \frac{x^2+4x+4}{x^2+x-2}$

Find equations for the horizontal or oblique asymptotes, if any, for each of the following rational functions. See Example 2.

19.  $f(x) = \frac{5}{x-1}$

20.  $f(x) = \frac{x^2+3}{x+3}$

21.  $f(x) = \frac{x^4 - 4}{x^2 + 2}$

23.  $f(x) = \frac{x + 2}{x^2 - 9}$

25.  $f(x) = \frac{2x^2 + 2x - 4}{x^2 + 2x + 1}$

27.  $f(x) = \frac{3x^2 + 1}{x - 2}$

29.  $f(x) = \frac{x^2 + 5}{x^3 - 27}$

31.  $f(x) = \frac{x^2 - 81}{x^3 + 7x - 12}$

33.  $f(x) = \frac{x^2 - 9x + 4}{x + 2}$

35.  $f(x) = \frac{5x^2 - x + 12}{x - 1}$

22.  $f(x) = \frac{x^2 - 4}{2x - x^2}$

24.  $f(x) = \frac{x^2 - 2x - 3}{2x^2 - 5x - 3}$

26.  $f(x) = \frac{-3x + 5}{x - 2}$

28.  $f(x) = \frac{x^3 - 27}{x^2 + 5}$

30.  $f(x) = \frac{x^2 + 2x}{x + 1}$

32.  $f(x) = \frac{x^3 - 3x^2 + 2x}{x - 7}$

34.  $f(x) = \frac{-x^5 + 2x^2}{5x^5 + 3x^3 - 7}$

36.  $f(x) = \frac{2x^2 - 5x + 6}{x - 3}$

Sketch the graphs of the following rational functions, making use of your work in the problems above and additional information about intercepts and any other points that may be useful. See Example 3.

37.  $f(x) = \frac{5}{x - 1}$

38.  $f(x) = \frac{x^2 + 3}{x + 3}$

39.  $f(x) = \frac{x^2 - 4}{x + 2}$

40.  $f(x) = \frac{x^2 - 4}{2x - x^2}$

41.  $f(x) = \frac{x + 2}{x^2 - 9}$

42.  $f(x) = \frac{x^2 - 2x - 3}{2x^2 - 5x - 3}$

43.  $f(x) = \frac{2x^2 + 2x - 4}{x^2 + 2x + 1}$

44.  $f(x) = \frac{-3x + 5}{x - 2}$

45.  $f(x) = \frac{3x^2 + 1}{x - 2}$

46.  $f(x) = \frac{x^3 - 27}{x^2 + 5}$

47.  $f(x) = \frac{x^2 + 5}{x^3 - 27}$

48.  $f(x) = \frac{x^2 + 2x}{x + 1}$

For each graph, find any **a.** vertical asymptotes, **b.** horizontal asymptotes, **c.** oblique asymptotes, **d.** visible  $x$ -intercepts, or **e.** visible  $y$ -intercepts.

49.

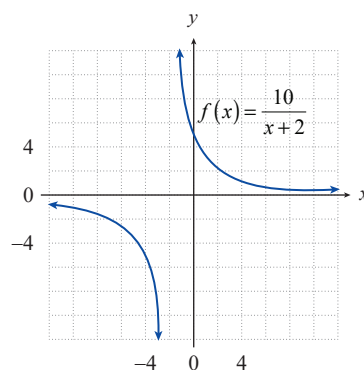

50.

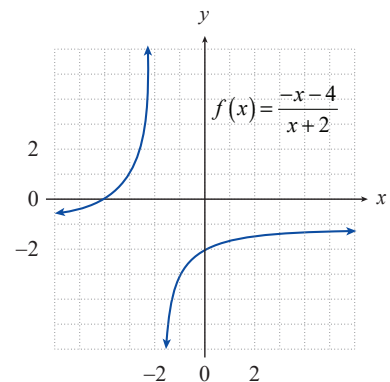

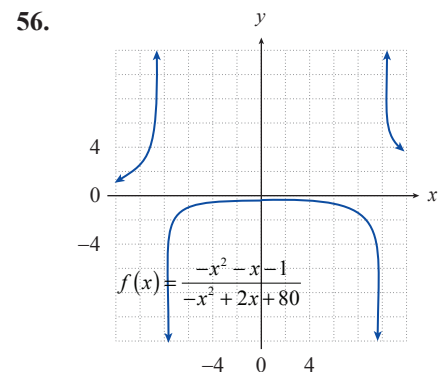
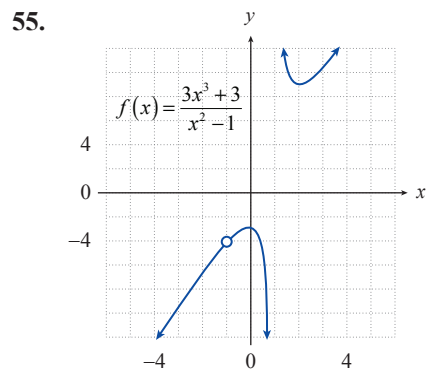
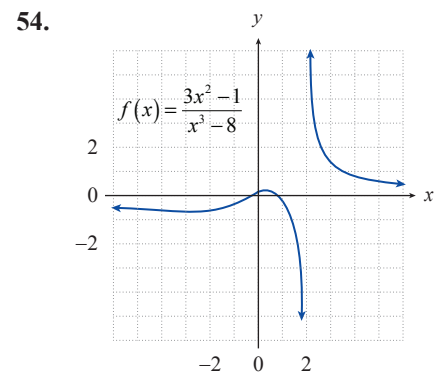
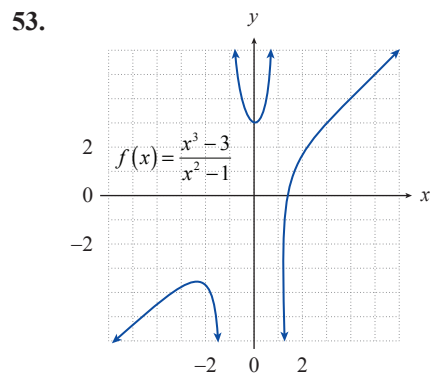
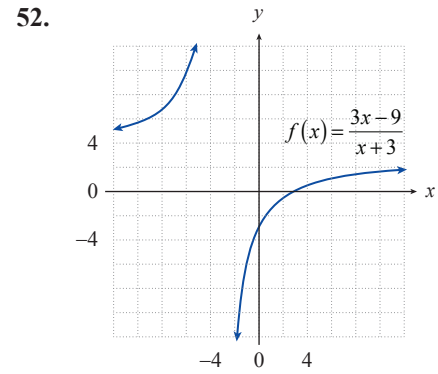
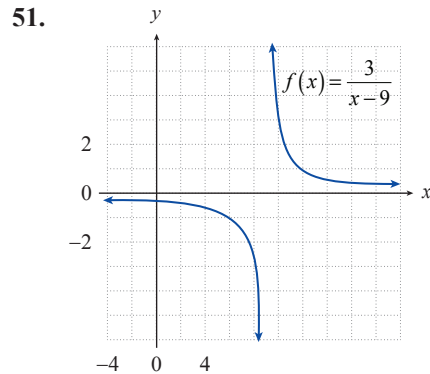

Solve the following rational inequalities. See Examples 4 and 5.

57.  $2x < \frac{4}{x+1}$

58.  $\frac{5}{x-2} \geq \frac{3x}{x-2}$

59.  $\frac{5}{x-2} > \frac{3}{x+2}$

60.  $\frac{x}{x^2-x-6} \leq \frac{-1}{x^2-x-6}$

61.  $\frac{x}{x^2-x-6} \leq \frac{-2}{x^2-x-6}$

62.  $x > \frac{1}{x}$

63.  $\frac{4}{x-3} \leq \frac{4}{x}$

64.  $\frac{x-7}{x-3} \geq \frac{x}{x-1}$

65.  $\frac{x}{x^2+3x+2} > \frac{1}{x^2+3x+2}$

66.  $\frac{1}{x-4} \geq \frac{1}{x+1}$

67.  $\frac{x}{x+1} \geq \frac{x+1}{x}$

68.  $\frac{x}{x^2-2x-3} > \frac{3}{x^2-2x-3}$

 APPLICATIONS

69. April raises a species of aquarium fish, and the total number of fish she has follows the formula

$$p(t) = \frac{200t}{t+1},$$

where  $t \geq 0$  represents the number of months since she began.

- Sketch the graph of  $p(t)$  for  $t \geq 0$ .
  - What happens to April's fish population in the long run?
70. If an object is placed a distance  $x$  from a lens with a focal length of  $f$ , the image of the object will appear a distance  $y$  on the opposite side of the lens, where  $x$ ,  $f$ , and  $y$  are related by the equation  $\frac{1}{x} + \frac{1}{y} = \frac{1}{f}$ .

- Express  $y$  as a function of  $x$  and  $f$ .
- Graph your function for a lens with a focal length of 30 mm ( $f = 30$ ). What happens to  $y$  as the distance  $x$  increases?

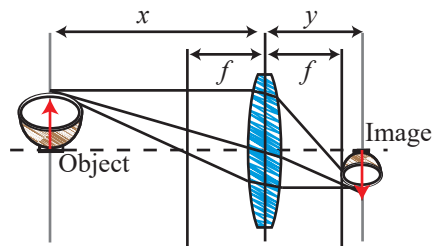

71. At  $t$  minutes after injection, the concentration (in mg/L) of a certain drug in the bloodstream of a patient is given by the formula

$$c(t) = \frac{20t}{t^2 + 1}.$$

- Sketch the graph of  $c(t)$  for  $t \geq 0$ .
- What happens to the concentration of the drug in the long run?

## 6.1 EXERCISES

### PRACTICE

Sketch the graphs of the following functions. State their domain and range. See Examples 1 and 2.

1.  $f(x) = 4^x$

2.  $g(x) = (0.5)^x$

3.  $s(x) = 3^{x-2}$

4.  $f(x) = \left(\frac{1}{3}\right)^{x+1}$

5.  $r(x) = 5^{x-2} + 3$

6.  $h(x) = 1 - 2^{x+1}$

7.  $f(x) = 2^{-x}$

8.  $r(x) = 3^{2-x}$

9.  $g(x) = 3(2^{-x})$

10.  $h(x) = 2^{2x}$

11.  $s(x) = (0.2)^{-x}$

12.  $f(x) = \frac{1}{2^x} + 1$

13.  $g(x) = 3 - 2^{-x}$

14.  $r(x) = \frac{1}{2^{3-x}}$

15.  $h(x) = \left(\frac{1}{2}\right)^{5-x}$

16.  $m(x) = 3^{2x+1}$

17.  $p(x) = 2 - 4^{2-x}$

18.  $q(x) = 5^{3-2x}$

19.  $r(x) = \left(\frac{9}{2}\right)^{-x}$

20.  $p(x) = \left(\frac{1}{3}\right)^{2-x}$

21.  $r(x) = 1 - \left(\frac{15}{4}\right)^x$

Solve the following exponential equations. See Example 3.

22.  $5^x = 125$

23.  $3^{2x-1} = 27$

24.  $9^{2x-5} = 27^{x-2}$

25.  $10^x = 0.01$

26.  $4^{-x} = 16$

27.  $2^x = \left(\frac{1}{2}\right)^{13}$

28.  $2^{x+1} = 64^3$

29.  $\left(\frac{2}{3}\right)^{x+3} = \left(\frac{9}{4}\right)^{-x}$

30.  $\left(\frac{1}{5}\right)^{x-4} = 625^{\frac{1}{2}}$

31.  $4^{3x+2} = \left(\frac{1}{4}\right)^{-2x}$

32.  $5^x = 0.2$

33.  $7^{x^2+3x} = \frac{1}{49}$

34.  $3^{x^2+4x} = 81^{-1}$

35.  $\left(\frac{1}{2}\right)^{x-3} = \left(\frac{1}{4}\right)^{x-5}$

36.  $64^{\frac{x+7}{6}} = 2$

37.  $6^{2x} = 36^{2x-3}$

38.  $4^{2x-5} = 8^{\frac{x}{2}}$

39.  $\left(\frac{2}{5}\right)^{2x+4} = \left(\frac{4}{25}\right)^{11}$

40.  $4^{4x-7} = \frac{1}{64}$

41.  $-10^x = -0.001$

42.  $3^x = 27^{x+4}$

43.  $1000^{-x} = 10^{x-8}$

44.  $1^{3x-7} = 4^{2-x}$

45.  $5^{3x-1} = 625^x$

46.  $3^{2x-7} = 81^{\frac{x}{2}}$

Match the graphs of the following functions to the appropriate equation.

47.  $f(x) = 2^{3x}$

48.  $h(x) = 5^x - 1$

49.  $g(x) = 2(4^{x-1})$

50.  $p(x) = 1 - 2^{-x}$

51.  $f(x) = 6^{4-x}$

52.  $r(x) = \frac{1}{3^x}$

53.  $m(x) = -2 + 2^{-3x}$

54.  $g(x) = \left(\frac{1}{4}\right)^{1+x}$

55.  $h(x) = 3^{2^x}$

56.  $s(x) = 1^x - 4$

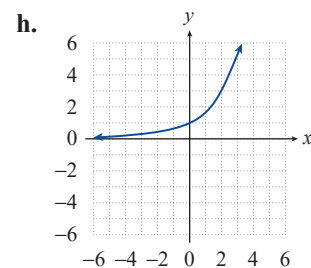
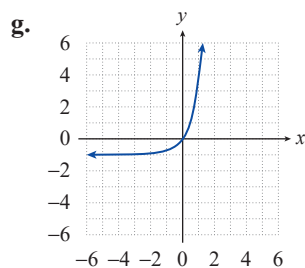
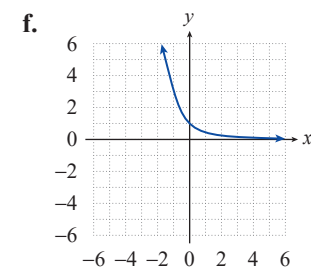
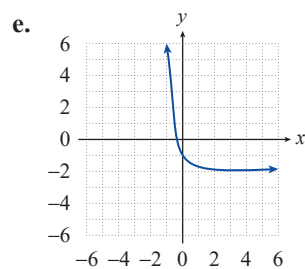
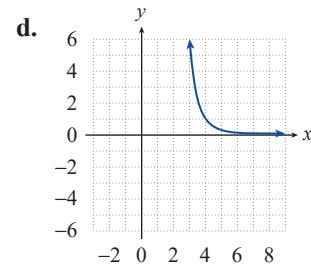
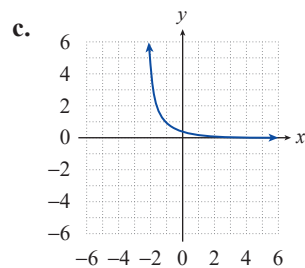
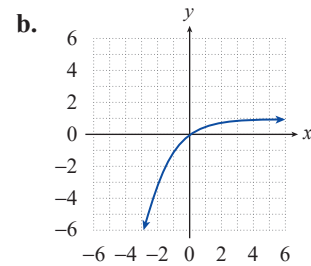
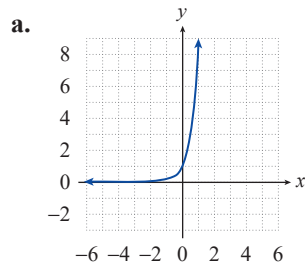

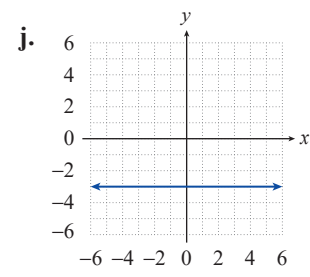
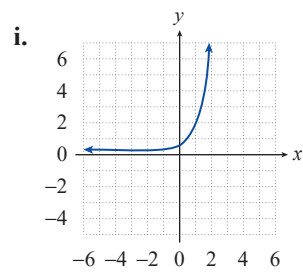

To illustrate the utility of a logistic curve in a modeling situation such as this, Figure 7 contains the graphs of the best-fitting line (the red line  $A$ ) and best-fitting parabola (the green curve  $B$ ) for the given data, along with the logistic curve just found (the blue curve  $C$ ). The graphs indicate that both linear and quadratic regression are inappropriate tools in this case, while the logistic regression function appears to be much more realistic. As a particular point of comparison, the weights predicted by the linear and quadratic models at the end of month 24 are, respectively, 92 pounds and 68 pounds, far outside the expected range of 40 to 45 pounds.

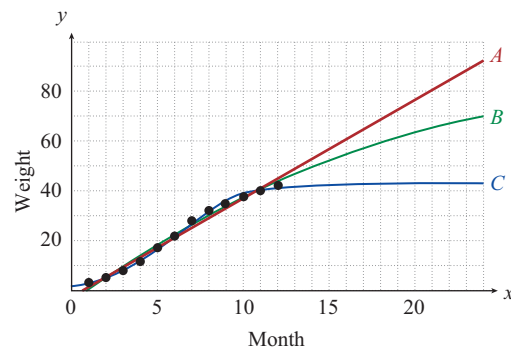

FIGURE 7

## 6.2 EXERCISES

### APPLICATIONS

1. A new virus has broken out in isolated parts of Africa and is spreading exponentially through tribal villages. The growth of this new virus can be mapped using the following formula where  $V$  stands for the number of people in the village who are infected with the virus,  $P$  stands for the number of people in a village and  $d$  stands for the number of days since the virus first appeared. According to this equation, how many people in a village of 300 will be infected after 5 days?
2. A prototype for an electric motorcycle uses a battery whose energy capacity  $C(d)$ , in kilowatt-hours (kWh), is given by the formula  $C(d) = 12e^{-0.02d}$ , where  $d$  represents the number of days since receiving a full charge. What is the battery's energy capacity 30 days after being fully charged?
3. A young economics student has come across a very profitable investment scheme in which his money will accrue interest according to the equation listed below, where  $C$  represents the investment value after  $m$  months for an initial investment of  $I$  dollars. If this student invests \$1250 into this lucrative endeavor, how much money will he have after 24 months?  $I$  represents the investment and  $m$  represents the number of months the money has been invested for.

$$V = P(1 - e^{-0.18d})$$

$$C = Ie^{0.08m}$$

- ©HAWKES LEARNING

4. A family releases a couple of pet rabbits into the wild. Upon being released the rabbits begin to reproduce at an exponential rate, as shown in the formula below. After 2 years how large is the rabbit population  $P$ , where  $n$  stands for the initial rabbit population (2) and  $m$  stands for the number of months?

$$P = ne^{0.5m}$$

5. Inside a business network, an email worm was downloaded by an employee. This worm goes through the infected computer's address book and sends itself to all the listed email addresses. This worm very rapidly works its way through the network following the equation below, where  $C$  is the number of computers in the network and  $W$  is the number of computers infected  $h$  hours after the worm is initially downloaded. After only 8 hours, how many computers has the worm infected if there are 150 computers in the network?

$$W = C(1 - e^{-0.12h})$$

6. A construction crew has been assigned to build an apartment complex. The work of the crew can be modeled using the exponential formula below, where  $A$  is the total number of apartments to be built,  $w$  is the number of weeks, and  $F$  is the number of finished apartments. Out of a total of 100 apartments, how many apartments have been finished after 4 weeks of work?

$$F = A(1 - e^{-0.1w})$$



7. The half-life of radium is approximately 1600 years.

- Determine  $a$  so that  $A(t) = A_0a^t$  describes the amount of radium left after  $t$  years, where  $A_0$  is the amount at time  $t = 0$ .
- How much of a 1-gram sample of radium would remain after 100 years?
- How much of a 1-gram sample of radium would remain after 1000 years?

8. The radioactive element polonium-210 has a relatively short half-life of 138 days, and one way to model the amount of polonium-210 remaining after  $t$  days is with the function  $A(t) = A_0e^{-0.005023t}$ , where  $A_0$  is the mass at time  $t = 0$  (note that  $A(140) = \frac{A_0}{2}$ .) What percentage of the original mass of a sample of polonium-210 remains after 365 days?

9. A certain species of fish is to be introduced into a new man-made lake, and wildlife experts estimate the population will grow according to  $P(t) = (1000)2^{\frac{t}{3}}$ , where  $t$  represents the number of years from the time of introduction.

- What is the doubling time for this population of fish?
- How long will it take for the population to reach 8000 fish, according to this model?



10. The population of a certain inner-city area is estimated to be declining according to the model  $P(t) = 237,000e^{-0.018t}$ , where  $t$  is the number of years from the present. What does this model predict the population will be in ten years?
11. In an effort to control vegetation overgrowth, 100 rabbits are released in an isolated area that is free of predators. After one year, it is estimated that the rabbit population has increased to 500. Assuming exponential population growth, what will the population be after another six months?
12. Assuming a current world population of 7.75 billion people, an annual growth rate of 1.9% per year, and a worst-case scenario of exponential growth, what will the world population be in **a.** 10 years? **b.** 50 years?
13. Madiha has \$3500 that she wants to invest in a simple savings account for two and a half years, at which time she plans to close out the account and use the money as a down payment on a car. She finds one local bank offering an annual interest rate of 2.75% compounded monthly, and another bank offering an annual interest rate of 2.7% compounded daily (365 times per year). Which bank should she choose?
14. Madiha, from the last problem, does some more searching and finds an online bank offering an annual rate of 2.75% compounded continuously. How much more money will she earn over two and a half years if she chooses this bank rather than the local bank offering the same rate compounded monthly?
15. Tom hopes to earn \$1000 in interest in three years time from \$10,000 that he has available to invest. To decide if it's feasible to do this by investing in a simple monthly compounded savings account, he needs to determine the annual interest rate such an account would have to offer for him to meet his goal. What would the annual rate of interest have to be?
16. An investment firm claims that its clients usually double their principal in five years time. What annual rate of interest would a savings account, compounded monthly, have to offer in order to match this claim?
17. The function  $C(t) = C_0(1+r)^t$  models the rise in the cost of a product that has a cost of  $C_0$  today, subject to an average yearly inflation rate of  $r$  for  $t$  years. If the average annual rate of inflation over the next decade is assumed to be 3%, what will the inflation-adjusted cost of a \$100,000 house be in 10 years? Round your answer to the nearest dollar.
18. Given the inflation model  $C(t) = C_0(1+r)^t$  (see Exercise 17), and given that a loaf of bread that currently sells for \$3.60 sold for \$3.10 six years ago, what has the average annual rate of inflation been for the past six years?
19. The function  $N(t) = \frac{10,000}{1 + 999e^{-t}}$  models the number of people in a small town who have caught the flu  $t$  weeks after the initial outbreak.
- How many people were ill initially?
  - How many people have caught the flu after eight weeks?
  - Determine what happens to the function  $N(t)$  as  $t \rightarrow \infty$ .

20. The concentration  $C(t)$ , in milligrams per liter, of a certain drug in the bloodstream after  $t$  minutes is given by the formula  $C(t) = 0.05(1 - e^{-0.2t})$ . What is the concentration after 10 minutes?
21. Carbon-11 has a radioactive half-life of approximately 20 minutes, and is useful as a diagnostic tool in certain medical applications. Because of the relatively short half-life, time is a crucial factor when conducting experiments with this element.
- Determine  $a$  so that  $A(t) = A_0 a^t$  describes the amount of carbon-11 left after  $t$  minutes, where  $A_0$  is the amount at time  $t = 0$ .
  - How much of a 2 kg sample of carbon-11 would be left after 30 minutes?
  - How many milligrams of a 2 kg sample of carbon-11 would be left after six hours?
22. Charles has recently inherited \$8000 that he wants to deposit into a savings account. He has determined that his two best bets are an account that compounds annually at a rate of 3.20% and an account that compounds continuously at an annual rate of 3.15%. Which account would pay Charles more interest?
23. Marshall invests \$1250 in a mutual fund which boasts a 5.7% annual return compounded semiannually (twice a year). After three and a half years, Marshall decides to withdraw his money.
- How much is in his account?
  - How much has he made in interest from his investment?
24. Adam is working in a lab testing bacteria populations. After starting out with a population of 375 bacteria, he observes the change in population and notices that the population doubles every 27 minutes.
- Find the equation for the population  $P$  in terms of time  $t$  in minutes, rounding  $a$  to the nearest thousandth.
  - Find the population after two hours.



25. Your credit union offers a special interest rate of 10% compounded monthly for the first year for a student savings account opened in August if the student deposits \$5000 or more. You received a total of \$9000 for graduation, and you decide to deposit all of it in this special account. Assuming you open your account in August and make no withdrawals for the first year, how much money will you have in your account at the end of February (after six months)? How much will you have at the end of the following July (after one full year)?
26. You have a savings account of \$3000 with an interest rate of 6.8%.
- How much interest would be earned in two years if the interest is compounded annually?
  - How much interest would be earned in two years if the interest is compounded semiannually?
  - In which case do you make more money on interest? Explain why this is so.

27. If \$2500 is invested in a continuously compounded certificate of deposit with an annual interest rate of 4.2%, what would be the account balance at the end of three years?
28. The new furniture store in town boasts a special in which you can buy any set of furniture in their store and make no monthly payments for the first year. However, the fine print says that the interest rate of 7.25% is compounded quarterly beginning when you buy the furniture. You are considering buying a set of living room furniture for \$4000 but know you cannot save up more than \$4500 in one year's time. Can you fully pay off your furniture on the one year anniversary of having bought the furniture? If so, how much money will you have left over? If not, how much more money will you need?
29. When Nicole was born, her grandmother was so excited about her birth that she opened a certificate of deposit in Nicole's honor to help send her to college. Now at age 18, Nicole's account has \$81,262.93. How much did her grandmother originally invest if the interest rate has been 8.1% compounded annually?
30. Inflation is a relative measure of your purchasing power over time. The formula for inflation is the same as the compound interest formula, but with  $n = 1$ . Given the current values below, what will the values of the following items be 10 years from now if inflation is at 6.4%?
- an SUV: \$38,000
  - a loaf of bread: \$1.79
  - a gallon of milk: \$3.40
  - your salary: \$34,000
31. Depreciation is the decrease of an item's value and can be determined using a formula similar to that for compound interest:
- $$V = P(1 - r)^t,$$
- where  $V$  is the new value.
- If the particular car you buy upon graduation from college costs \$17,500 and depreciates at a rate of 16% per year, what will the value of the car be in 5 years when you pay it off?
32. Assume the interest on your credit card is compounded continuously with an APR (annual percentage rate) of 19.8%. If you put your first term bill of \$3984 on your credit card, but do not have to make payments until you graduate (4 years later), how much will you owe when you start making payments?
33. Suppose you deposit \$5000 in an account for five years at an annual interest rate of 8.5%.
- What would be the ending account balance if the interest is continuously compounded?
  - What would be the ending account balance if the interest is compounded daily?
  - Are these two answers similar? Why or why not?

 Use the regression commands on a TI-84 Plus to fit the requested curves. See Examples 6 and 7.

34. Linda invested \$10,000 in the stock market five years ago and has recorded the value of her investment annually since then, as shown in the table.

| Year | Value    |
|------|----------|
| 0    | \$10,000 |
| 1    | \$10,800 |
| 2    | \$11,400 |
| 3    | \$12,300 |
| 4    | \$13,200 |
| 5    | \$14,100 |

- Find an exponential function that models the growth of her investment over the past five years.
- Use your result to estimate the value of her investment after one more year, assuming she continues to earn the same effective annual interest rate.

35. The table contains US population data for the census years from 1850 to 1900.

| Year | Population |
|------|------------|
| 1850 | 23,191,876 |
| 1860 | 31,443,321 |
| 1870 | 38,558,371 |
| 1880 | 50,189,209 |
| 1890 | 62,979,766 |
| 1900 | 76,212,168 |

- Use linear, quadratic, and exponential regression to fit curves to the data.
- Use your results to extrapolate back in time to estimate the US population in the year 1800, and compare the estimates with the actual US Census population in that year of 5,308,483. What do you conclude about extrapolation of these regression models so far outside the known data?

**Source:** US Census Bureau

36. A biologist conducts a six-month field study of a small plot of land, collecting data on, among other things, the population of a species of meadow mouse.

- Fit an exponential curve to the data, and use your result to extrapolate the mouse population at the end of one year.
- Fit a logistic curve to the data, and use your result to extrapolate the mouse population at the end of one year.
- What do you conclude about these two regression models and extrapolation so far outside the known data?

| Month | Population |
|-------|------------|
| 0     | 2          |
| 1     | 3          |
| 2     | 5          |
| 3     | 7          |
| 4     | 10         |
| 5     | 12         |
| 6     | 13         |

### TECHNOLOGY

Use a graphing utility to sketch the graphs of the following functions.

37.  $m(x) = 1 - 3e^x$

38.  $p(x) = e^{4x} - 2$

39.  $b(x) = \frac{1}{e^{x-2}}$

40.  $m(x) = e^{2x^2 - 3x + 1}$

41.  $g(x) = e^{x+3} - 3$

42.  $m(x) = 6e^{2x} - 2$

**Example 6:** Evaluating Logarithmic Expressions

Evaluate the following logarithmic expressions.

a.  $\ln(\sqrt[3]{e})$

b.  $\log 1000$

c.  $\ln(4.78)$

d.  $\log(10.5)$

**Solution**

a.  $\ln(\sqrt[3]{e}) = \ln\left(e^{\frac{1}{3}}\right) = \frac{1}{3}$

No calculator is necessary for this problem, just an application of an elementary property of logarithms.

b.  $\log 1000 = \log(10^3) = 3$

Again, no calculator is required.

c.  $\ln(4.78) \approx 1.564$

This time, a calculator is needed, and only an approximate answer can be given. Be sure to use the correct logarithm.

d.  $\log(10.5) \approx 1.021$

Again, we must use a calculator, though we can say beforehand that the answer should be only slightly larger than 1, as  $\log 10 = 1$  and 10.5 is only slightly larger than 10.

**6.3 EXERCISES****PRACTICE**

Write the following equations in logarithmic terms.

1.  $625 = 5^4$

2.  $216 = 6^3$

3.  $x^3 = 27$

4.  $b^2 = 3.2$

5.  $4.2^3 = C$

6.  $1.3^2 = V$

7.  $4^x = 31$

8.  $16^{2x} = 215$

9.  $(4x)^{\sqrt{3}} = 13$

10.  $e^x = \pi$

11.  $2^{e^x} = 11$

12.  $4^e = N$

Write the following logarithmic equations as exponential equations.

13.  $\log_3 81 = 4$

14.  $\log_2 \left(\frac{1}{8}\right) = -3$

15.  $\log_b 4 = \frac{1}{2}$

16.  $\log_y 9 = 2$

17.  $\log_2 15 = b$

18.  $\log_5 8 = d$

19.  $\log_5 W = 12$

20.  $\log_7 T = 6$

21.  $\log_\pi(2x) = 4$

22.  $\log_{\sqrt{3}}(2\pi) = x$

23.  $\ln 2 = x$

24.  $\ln(5x) = 3$

Sketch the graphs of the following functions. State their domain and range. See Examples 2 and 3.

25.  $f(x) = \log_3(x - 1)$

26.  $g(x) = \log_5(x + 2) - 1$

27.  $r(x) = \log_{\frac{1}{2}}(x - 3)$

28.  $p(x) = 3 - \log_2(x + 1)$

29.  $q(x) = \log_3(2 - x)$

30.  $s(x) = \log_{\frac{1}{3}}(5 - x)$

31.  $h(x) = \log_7(x - 3) + 3$

32.  $m(x) = \log_{\frac{1}{2}}(1 - x)$

33.  $f(x) = \log_3(6 - x)$

34.  $p(x) = 4 - \log(x + 3)$

35.  $s(x) = -\log_{\frac{1}{3}}(-x)$

36.  $g(x) = \log_5(2x) - 1$

Match the graph of the appropriate equation to the logarithmic function.

37.  $f(x) = \log_2(x - 1)$

38.  $f(x) = \log_2(2 - x)$

39.  $f(x) = \log_2(-x)$

40.  $f(x) = \log_2(x - 3)$

41.  $f(x) = 1 - \log_2 x$

42.  $f(x) = -\log_2 x$

43.  $f(x) = -\log_2(-x)$

44.  $f(x) = \log_2 x$

45.  $f(x) = \log_2(x + 3)$

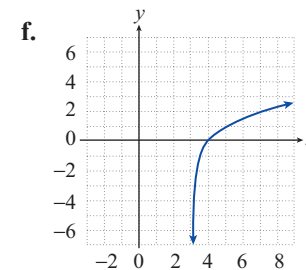
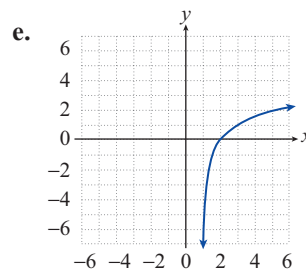
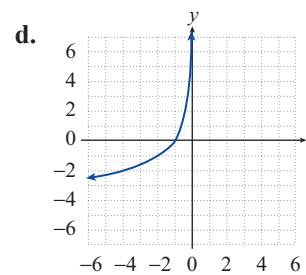
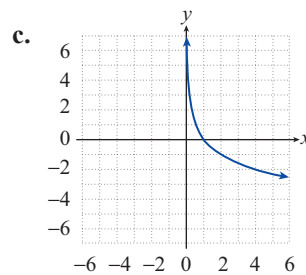
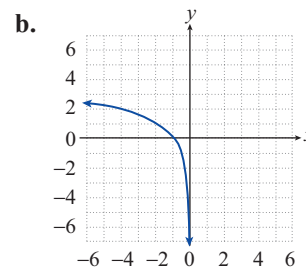
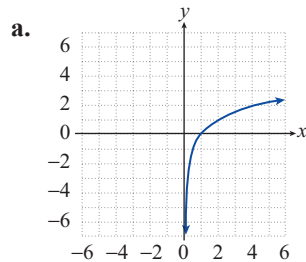

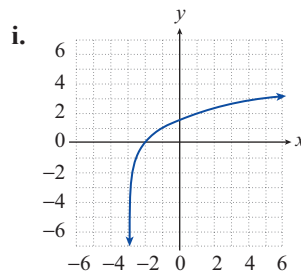
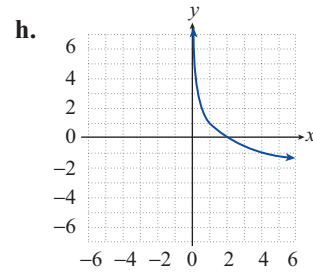
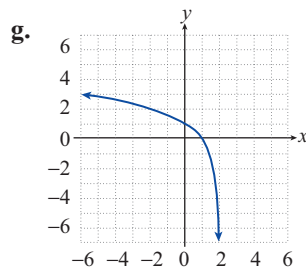

Evaluate the following logarithmic expressions without the use of a calculator. See Examples 4 and 6.

46.  $\log_7(\sqrt{7})$

47.  $\log_{\frac{1}{2}} 4$

48.  $\log_9\left(\frac{1}{81}\right)$

49.  $\log_3 27$

50.  $\log_{27} 3$

51.  $\log_9\left(\frac{1}{3}\right)$

52.  $\log_{27} 9$

53.  $\log_{\frac{1}{16}}\left(\frac{1}{8}\right)$

54.  $\log_3(\log_{27} 3)$

55.  $\ln e^{2.89}$

56.  $\log(0.0001)$

57.  $\log_a\left(a^{\frac{5}{3}}\right)$

58.  $\ln\left(\frac{1}{e}\right)$

59.  $\log(\log(10^{10}))$

60.  $\log_3 1$

61.  $\ln(\sqrt[5]{e})$

62.  $\log_{\frac{1}{16}} 4$

63.  $\log_8 4^{\log 1000}$

Use the elementary properties of logarithms to solve the following equations. See Example 5.

64.  $\log_{16} x = \frac{3}{4}$

65.  $\log_{16}\left(x^{\frac{1}{2}}\right) = \frac{3}{4}$

66.  $\log_{16} x = -\frac{3}{4}$

67.  $\log_5(5^{\log_3 x}) = 2$

68.  $\log_a(a^{\log_b x}) = 0$

69.  $\log_3(9^{2x}) = -2$

70.  $\log_{\frac{1}{3}}(3^x) = 2$

71.  $\log_7(3x) = -1$

72.  $4^{\log_3 x} = 0$

73.  $\log(x^{10}) = 10$

74.  $\log_x\left(\log_{\frac{1}{2}}\left(\frac{1}{4}\right)\right) = 1$

75.  $6^{\log_x(e^2)} = e$

**Hint:** Note that  $\log_a b = \log_{a^2} b^2$ . This follows from the fact that  $\log_a b = y \Leftrightarrow b = a^y \Leftrightarrow b^2 = a^{2y} = (a^2)^y \Leftrightarrow \log_{a^2} b^2 = y$ .

Solve the following logarithmic equations, using a calculator if necessary to evaluate the logarithms. See Examples 5 and 6. Express your answer either as a fraction or a decimal rounded to two decimal places.

76.  $\log(3x) = 2.1$

77.  $\log(x^2) = -2$

78.  $\ln(x + 1) = 3$

79.  $\ln(2x) = -1$

80.  $\ln(e^x) = 5.6$

81.  $\ln(\ln(x^2)) = 0$

82.  $\log 19 = 3x$

83.  $\log(e^x) = 5.6$

84.  $\log_9(2x - 1) = 2$

85.  $\log(\log(x - 2)) = 1$

86.  $\log(300^{\log x}) = 9$

### TECHNOLOGY

To find and graph the logarithmic function of best fit for a given set of points using a TI-84 Plus, perform the same steps as described in Section 3.2 for linear regression except select **LnReg** from the **CALC** menu.

### Example 9: Logarithmic Regression

A manufacturer of aviation instruments has designed a new pressure altimeter, a device that determines altitude as a function of atmospheric pressure. The data in Table 1 was collected in order to calibrate the device, where the pressure  $p$  (in pascals) was measured by the new device and its altitude  $h$  above sea level (in meters) was measured by another instrument of known accuracy. Use the data and logarithmic regression to find a logarithmic function that models altitude as a function of pressure and plot its graph along with the given points.

|                           |        |        |        |        |        |        |         |
|---------------------------|--------|--------|--------|--------|--------|--------|---------|
| Pressure $p$ (in pascals) | 40,000 | 50,000 | 60,000 | 70,000 | 80,000 | 90,000 | 100,000 |
| Altitude $h$ (in meters)  | 7309   | 5670   | 4279   | 3064   | 1982   | 1005   | 113     |

TABLE 1

### Solution

Entering the data into a TI-84 Plus and performing a logarithmic regression results in the function  $h(p) = 90,678.9 - 7859.23 \ln p$ . This is the logarithmic curve of best fit for the given data. The data is displayed in Figure 2, and the graph is shown in Figure 3.



FIGURE 2

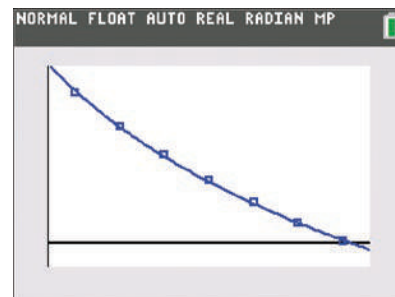

FIGURE 3

## 6.4 EXERCISES

### PRACTICE

Use the properties of logarithms to expand the following expressions as much as possible. Simplify any numerical expressions that can be evaluated without a calculator. See Example 3.

- $\log_5(125x^3)$
- $\ln\left(\frac{x^2y}{3}\right)$
- $\ln\left(\frac{e^2p}{q^3}\right)$
- $\log(100x)$
- $\log_9(9xy^{-3})$
- $\log_6\left(\sqrt[3]{\frac{p^2}{q}}\right)$
- $\ln\left(\frac{\sqrt{x^3pq^5}}{e^7}\right)$
- $\log_a\sqrt[5]{\frac{a^4b}{c^2}}$
- $\log(\log(100x^3))$

10.  $\log_3(9x + 27y)$       11.  $\log\left(\frac{10}{\sqrt{x+y}}\right)$       12.  $\ln(\ln(e^{e^x}))$
13.  $\log_2\left(\frac{y^2+z}{16x^4}\right)$       14.  $\log(\log(100,000^{2x}))$       15.  $\log_b\left(\sqrt{\frac{x^4y}{z^2}}\right)$
16.  $\ln(7x^2 - 42x + 63)$       17.  $\log_b(ab^2c^b)$       18.  $\ln(\ln(e^{e^x}))$

Use the properties of logarithms to condense the following expressions as much as possible, writing each answer as a single term with a coefficient of 1. See Example 4.

19.  $\log x - \log y$       20.  $\log_5 x - 2\log_5 y$
21.  $\log_5(x^2 - 25) - \log_5(x - 5)$       22.  $\ln(x^2y) - \ln y - \ln x$
23.  $\frac{1}{3}\log_2 x + \log_2(x + 3)$       24.  $\frac{1}{5}(\log_7(x^2) - \log_7(pq))$
25.  $\ln 3 + \ln p - 2\ln q$       26.  $2(\log_5(\sqrt{x}) - \log_5 y)$
27.  $\log(x - 10) - \log x$       28.  $2\log a^2b - \log\left(\frac{1}{b}\right) + \log\left(\frac{1}{a}\right)$
29.  $3(\ln(\sqrt[3]{z^2}) - \ln(xy))$       30.  $\log_2(4x) - \log_2 x$
31.  $\log_5 20 - \log_5 5$       32.  $\log 30 - \log 2 - \log 5$
33.  $\ln 15 + \ln 3$       34.  $\ln 8 - \ln 4 + \ln 3$
35.  $0.5\log_3 16 - \log_3 4$       36.  $3\log_7 2 - 2\log_7 4$
37.  $0.25\ln 81 + \ln 4$       38.  $2(\log 4 - \log 1 + \log 2)$
39.  $\log 11 + 0.5\log 9 - \log 3$       40.  $3\log_4(x^2) + \log_4(x^6)$
41.  $\log_8(2x^2 - 2y) - 0.25\log_8 16$       42.  $\log_{3x} x^2 + \log_{3x} 18 - \log_{3x} 6$

Use the properties of logarithms to write each of the following as a single term that does not contain a logarithm.

43.  $5^{2\log_5 x}$       44.  $10^{\log y^2 - 3\log x}$       45.  $e^{2-\ln x + \ln p}$
46.  $e^{5(\ln \sqrt[3]{3} + \ln x)}$       47.  $10^{\log x^3 - 4\log y}$       48.  $a^{\log_a b + 4\log_a \sqrt{a}}$
49.  $10^{2\log x}$       50.  $10^{4\log x - 2\log x}$       51.  $\log_4 16 \cdot \log_x x^2$
52.  $e^{\ln x + 2 + \ln x^2}$       53.  $4^{\log_4(3x) + 0.5\log_4(16x^2)}$       54.  $4^{2\log_2 6 - \log_2 9}$

Evaluate the following logarithmic expressions. See Example 5.

55.  $\log_4 17$       56.  $2\log_{\frac{1}{3}} 5$       57.  $\log_9 8$
58.  $\log_2 0.01$       59.  $\log_{12} 10.5$       60.  $\log(\ln 2)$
61.  $\log_6 3^4$       62.  $\log_7 14.3$       63.  $\log_{\frac{1}{2}} \pi^{-2}$

- |                              |                     |                       |
|------------------------------|---------------------|-----------------------|
| 64. $\log_{\frac{1}{5}} 626$ | 65. $\ln(\log 123)$ | 66. $\log_{17} 0.041$ |
| 67. $\log 16$                | 68. $\log_3 9$      | 69. $\log_5 20$       |
| 70. $\log_8 26$              | 71. $\log_4 0.25$   | 72. $\log_{1.8} 9$    |
| 73. $\log_{2.5} 34$          | 74. $\log_{0.5} 10$ | 75. $\log_4 2.9$      |
| 76. $\log_{0.4} 14$          | 77. $\log_{0.2} 17$ | 78. $\log_{0.16} 2.8$ |

Without using a calculator, evaluate the following expressions.

- |                           |                              |   |
|---------------------------|------------------------------|---|
| 79. $\log_4 16$           | 80. $\log_5 25^3$            | 81. $\ln e^4 + \ln e^3$                 |
| 82. $\log_4 \frac{1}{64}$ | 83. $\ln e^{1.5} - \log_4 2$ | 84. $\log_2 8^{(2\log_2 4 - \log_2 4)}$ |

Find the value of  $x$  in each of the following equations. Express your answer as exact as possible, or as a decimal rounded to two decimal places.

- |                       |                         |                      |
|-----------------------|-------------------------|----------------------|
| 85. $\log_x 1024 = 4$ | 86. $\log_6 729 = x$    | 87. $\log_2 529 = x$ |
| 88. $\log_4 625 = x$  | 89. $\log_x 729 = 9$    | 90. $\log_4 x = 8$   |
| 91. $\log_{12} x = 1$ | 92. $\log_x 16,807 = 7$ | 93. $\log_4 x = 10$  |

### APPLICATIONS

94. A certain brand of tomato juice has a  $[\text{H}_3\text{O}^+]$  concentration of  $6.31 \times 10^{-5}$  moles/liter. What is the pH of this brand?
95. One type of detergent, when added to neutral water with a pH of 7, results in a solution with a  $[\text{H}_3\text{O}^+]$  concentration that is  $5.62 \times 10^{-4}$  times weaker than that of the water. What is the pH of the solution?
96. What is the concentration of  $[\text{H}_3\text{O}^+]$  in lemon juice with a pH of 2.1?
97. An earthquake in Chile in 2019 measured 6.7 on the Richter scale. What was the intensity, relative to a 0-level earthquake, of this event?
98. How much stronger was the 2001 Gujarat earthquake (6.9 on the Richter scale) than the 2019 earthquake described in Exercise 97?
99. A construction worker operating a jackhammer would experience noise with an intensity of 20 watts/meter<sup>2</sup> if it weren't for ear protection. Given that  $I_0 = 10^{-12}$  watts/meter<sup>2</sup>, what is the decibel level for such noise?
100. A microphone picks up the sound of a thunderclap and measures its decibel level as 105. Given that  $I_0 = 10^{-12}$  watts/meter<sup>2</sup>, with what sound intensity did the thunderclap reach the microphone?

101. Matt, a lifeguard, has to make sure that the pH of the swimming pool stays between 7.2 and 7.6. If the pH is out of this range, he has to add chemicals that alter the pH level of the pool. If Matt measures the  $[\text{H}_3\text{O}^+]$  concentration in the swimming pool to be  $2.40 \times 10^{-8}$  moles/liter, what is the pH? Does he need to change the pH by adding chemicals to the water?



102. The intensity of a cat's soft purring is measured to be  $2.19 \times 10^{-11}$ . Given that  $I_0 = 10^{-12}$  watts/meter<sup>2</sup>, what is the decibel level of this noise?



103. Newton's Law of Cooling states that the rate at which an object cools is proportional to the difference between the temperature of the object and the surrounding temperature. If  $C$  denotes the surrounding temperature and  $T_0$  denotes the temperature at time  $t = 0$ , the temperature of an object at time  $t$  is given by  $T(t) = C + (T_0 - C)e^{-kt}$ , where  $k$  is a constant that depends on the particular object under discussion.
- You are having friends over for tea and want to know how long after boiling the water it will be drinkable. If the temperature of your kitchen stays around  $74^\circ\text{F}$  and you found online that the constant  $k$  for tea is approximately 0.049, how many minutes after boiling the water will the tea be drinkable (you prefer your tea no warmer than  $140^\circ\text{F}$ )? Recall that water boils at  $212^\circ\text{F}$ .
  - As you intern for your local crime scene investigation department, you are asked to determine at what time a victim died. If you are told  $k$  is approximately 0.1947 for a human body and the body's temperature was  $72^\circ\text{F}$  at 1:00 a.m., and the body has been in a storage building at a constant  $60^\circ\text{F}$ , approximately what time did the victim die? Recall the average temperature for a human body is  $98.6^\circ\text{F}$ . Note in this situation,  $t$  is measured in hours.
  - When helping your father cook a turkey, you were told to remove the turkey when the thickest part had reached  $180^\circ\text{F}$ . If you remove the turkey and place it on the table in a room that is  $72^\circ\text{F}$ , and it cools to  $155^\circ\text{F}$  in 20 minutes, what will the temperature of the turkey be at lunch time (an hour and 15 minutes after the turkey is removed from the oven)? Should you warm the turkey before eating?

 TECHNOLOGY

Use a TI-84 Plus to find and graph a logarithmic function of best fit along with the given data. See Example 9.

- 104.** The menu developers for a chain of coffee shops have conducted experiments to see how long customers take to make a drink choice, based on the number of drinks on the menu. Normalizing so that the average time needed to make a choice given just two drinks is 1 time unit, the average times needed to make a choice given  $n$  drinks on the menu are shown in the table below.

|   |   |     |     |   |     |     |
|---|---|-----|-----|---|-----|-----|
| <b>Number <math>n</math> of choices</b>             | 2 | 3   | 4   | 5 | 6   | 7   |
| <b>Average time <math>t</math> to make a choice</b> | 1 | 1.4 | 1.7 | 2 | 2.2 | 2.3 |

- 105.** The manufacturer of the new pressure altimeter in Example 9 expects the relative error in measured pressure to be larger for lower pressure values, so for pressures in the range of 25,000 pascals to 50,000 pascals altitude recordings were taken at 5000 pascal increments, as shown in the table below.

|   |        |        |        |        |        |        |
|---|--------|--------|--------|--------|--------|--------|
| <b>Pressure <math>p</math> (in pascals)</b> | 25,000 | 30,000 | 35,000 | 40,000 | 45,000 | 50,000 |
| <b>Altitude <math>h</math> (in meters)</b>  | 10,541 | 9321   | 8257   | 7309   | 6452   | 5670   |

## 6.5 EXERCISES

### PRACTICE

Solve the following exponential and logarithmic equations. Round your answer to two decimal places if necessary. See Examples 1 through 4.

1.  $3e^{5x} = 11$

2.  $4^{3-2x} = 7$

3.  $11^{\frac{3}{x}} = 10$

4.  $8^{3x+2} = 7^{2x+3}$

5.  $e^{15-3x} = 28$

6.  $10^{\frac{5}{x}} = 150$

7.  $10^{2x+5} = e$

8.  $e^{8x+e} = 8^{ex+8}$

9.  $6^{x-7} = 7$

10.  $2e^{3x} = 145$

11.  $2^{6-x} = 10$

12.  $e^{3x-6} = 10^{x+2}$

13.  $e^{-4x-2} = 12$

14.  $10^{x-9} = 2001$

15.  $e^{x-4} = 4^{\frac{2x}{3}}$

16.  $5^{x-2} = 20$

17.  $8^{x^2+1} = 23$

18.  $3^{\frac{4}{x}} = 15$

19.  $6^{3x-4} = 36^{2x+4}$

20.  $81^x = 3^{2x+16}$

21.  $e^{2x} = 14$

22.  $e^{4x} = e^{3x+14}$

23.  $5^{5x-7} = 10^{2x}$

24.  $10^{6x} = 3^{3x+4}$

25.  $\log_5 x = 3$

26.  $\log_2 x = 4$

27.  $\log x + \log(4x) = 2$

28.  $\log_4(x^2) - \log_4 x = 2$

29.  $\ln(2x) - \ln 4 = 3$

30.  $\ln(15x) - \ln 3 = 6$

31.  $\log_4(x-3) + \log_4 2 = 3$

32.  $\log_3 24 - \log_3 4 = x - 5$

33.  $\log_5(8x) - \log_5 3 = 2$

34.  $e^{2\ln x} = 4\log 10$

35.  $9^{\log_3 x} = 16$

36.  $3\log_8(512^{x^2}) = 36$

37.  $\log_3(6x) - 2\log_3(6x) = 3$

38.  $\ln(3e) = \log x$

39.  $\ln(2^{4e^x}) = \ln(16^e)$

40.  $\log(x-2) + \log(x+2) = 2$

41.  $\log(x-3) + \log(x+3) = 4$

42.  $\log_2(7x-4) = \log_2(16-3x)$

43.  $\log_\pi(x-5) + \log_\pi(x+3) = \log_\pi(1-2x)$

44.  $\log_3(x+3) + \log_3(x-5) = 2$

45.  $\log x + \log(x-3) = 1$

46.  $\log_7(3x+2) - \log_7 x = \log_7 4$

47.  $\log_2 x + \log_2(x-7) = 3$

48.  $\log_{12}(x-2) + \log_{12}(x-1) = 1$

49.  $\log_3(x+1) - \log_3(x-4) = 2$

50.  $\ln(x+1) + \ln(x-2) = \ln(x+6)$

51.  $\log_4(x-3) + \log_4(x-2) = \log_4(x+1)$

52.  $2 \ln(x + 3) = \ln(12x)$

53.  $\log_5(x - 1) + \log_5(x + 4) = \log_5(x - 5)$

54.  $\log_{255}(2x + 3) + \log_{255}(2x + 1) = 1$

55.  $\log_2(x - 5) + \log_2(x + 2) = 3$

56.  $\log_6(x + 1) + \log_6(x - 4) = 2$       57.  $\ln(x + 2) + \ln(x) = 0$

58.  $e^{2x} - 3e^x - 10 = 0$  (**Hint:** First solve for  $e^x$ .)

59.  $2^{2x} - 12(2^x) + 32 = 0$  (**Hint:** First solve for  $2^x$ .)

60.  $e^{2x} + 2e^x - 8 = 0$

61.  $3^{2x} - 12(3^x) + 27 = 0$

Using the properties of logarithmic functions, simplify the following functions as much as possible. Write each function as a single term with a coefficient of 1, if possible.

62.  $f(x) = 0.5 \ln(x^2)$

63.  $f(x) = 0.25 \log(16x^8)$

64.  $f(x) = 4 \ln(\sqrt{5x})$

65.  $f(x) = 8 \ln(\sqrt[4]{3x})$

66.  $f(x) = 3 \ln(e^x) - 3$

67.  $f(x) = 10^{2x \log 16}$

68.  $f(x) = 2 \ln(x^3) + \ln(x^6)$

69.  $f(x) = 2 \ln(x^3) - \ln(x^6)$

70.  $f(x) = \ln(x^2 + x) - \ln x$

71.  $f(x) = 2 \ln(5^{x \log_{20}(2\sqrt{5})})$

72.  $f(x) = e^{\ln(\log_x e^{-1})}$

73.  $f(x) = 2 \ln(5^{\log_4 2})$

### APPLICATIONS

74. Assuming that there are currently 8 billion people on Earth and a growth rate of 1.9% per year, how long will it take for Earth's population to reach 20 billion?

75. How long does it take for an investment to double in value if

a. The investment is in a monthly-compounded savings account earning 4% a year?

b. The investment is in a continuously-compounded account earning 7% a year?

76. Assuming a half-life of 5728 years, how long would it take for 3 grams of carbon-14 to decay to 1 gram?

77. Suppose a population of bacteria in a Petri dish has a doubling time of one and a half hours. How long will it take for an initial population of 10,000 bacteria to reach 100,000?

78. According to Newton's Law of Cooling, the temperature  $T(t)$  of a hot object, at time  $t$  after being placed in an environment with a constant temperature  $C$ , is given by  $T(t) = C + (T_0 - C)e^{-kt}$ , where  $T_0$  is the temperature of the object at time  $t = 0$  and  $k$  is a constant that depends on the object.

If a hot cup of coffee, initially at 190 °F, cools to 125 °F in 5 minutes when placed in a room with a constant temperature of 75 °F, how long will it take for the coffee to reach 100 °F?

79. Wayne has \$12,500 in a high interest savings account at 3.66% annual interest compounded monthly. Assuming he makes no deposits or withdrawals, how long will it take for his investment to grow to \$15,000?
80. Ben and Casey both open money market accounts with 4.9% annual interest compounded continuously. Ben opens his account with \$8700 while Casey opens her account with \$3100.
- How long will it take Ben's account to reach \$10,000?
  - How long will it take Casey's account to reach \$10,000?
  - How much money will be in Ben's account after the time found in part b.?
81. Cesium-137 has a half-life of approximately 30 years. How long would it take for 160 grams of cesium-137 to decay to 159 grams?
82. A chemist, running tests on an unknown sample from an illegal waste dump, isolates 50 grams of what he suspects is a radioactive element. In order to help identify the element, he would like to know its half-life. He determines that after 40 days only 44 grams of the original element remains. What is the half-life of this mystery element?

### TECHNOLOGY

The dollar-cost averaging application in this section concluded with the equation

$$x^{n+1} - \left(\frac{A}{P} + 1\right)x + \frac{A}{P} = 0,$$

where  $A$  represents the total accumulation in an account in which amount  $P$  has been invested every month for  $n$  months. A graphing utility can be used to solve the equation for  $x$  when given known values for  $A$ ,  $P$ , and  $n$ . Then the equivalent monthly-compounded annual rate of interest  $r$  can be found by solving the equation

$$x = 1 + \frac{r}{12}.$$

For instance, if a monthly investment of  $P = 100$  dollars for  $n = 12$  months results in an accumulation of  $A = 1300$  dollars, the first step is to solve the following equation.

$$x^{12+1} - \left(\frac{1300}{100} + 1\right)x + \frac{1300}{100} = 0 \Rightarrow x^{13} - 14x + 13 = 0$$

As noted,  $x = 1$  will always be one solution to the dollar-cost averaging equation, but the second positive solution is the one we seek. The second solution will lie between 0 and 1 if the equivalent rate  $r$  is negative and will be larger than 1 if  $r$  is positive. In this case, since \$1200 has been invested and the total accumulation after 12 months is \$1300, we know  $r$  is positive, and a graphing utility tells us that the second solution is indeed greater than 1; specifically,  $x \approx 1.01225$ . Solving  $1.01225 = 1 + \frac{r}{12}$  for  $r$  gives us  $r \approx 0.147$ , or  $r \approx 14.7\%$ .

Use a graphing utility to determine the equivalent monthly-compounded interest rate  $r$  in each of the following scenarios, where  $P$  represents the amount invested each month and  $A$  is the accumulated value at the end of  $n$  months.

83.  $n = 24$ ,  $P = \$50.00$ , and  $A = \$1275.00$

84.  $n = 120$ ,  $P = \$100.00$ , and  $A = \$15,000.00$

85.  $n = 12$ ,  $P = \$50.00$ , and  $A = \$590.00$

86.  $n = 24$ ,  $P = \$75.00$ , and  $A = \$2000.00$

## 7.1 EXERCISES

 PRACTICE

Convert the radian measure to degrees. See Example 1.

- |                      |                      |                       |                      |                       |
|----------------------|----------------------|-----------------------|----------------------|-----------------------|
| 1. $\frac{5\pi}{4}$  | 2. $\frac{\pi}{180}$ | 3. $-\frac{3\pi}{8}$  | 4. $-\frac{7\pi}{6}$ | 5. $\frac{2\pi}{3}$   |
| 6. $\frac{7\pi}{20}$ | 7. $\frac{5\pi}{6}$  | 8. $\frac{11\pi}{10}$ | 9. $-\frac{9\pi}{4}$ | 10. $-\frac{5\pi}{3}$ |

Convert the degree measure to radians. See Example 1.

- |                 |                 |                 |                 |                 |
|-----------------|-----------------|-----------------|-----------------|-----------------|
| 11. $47^\circ$  | 12. $93^\circ$  | 13. $132^\circ$ | 14. $154^\circ$ | 15. $148^\circ$ |
| 16. $120^\circ$ | 17. $480^\circ$ | 18. $520^\circ$ | 19. $125^\circ$ | 20. $90^\circ$  |

Convert each of the following angle measures as directed. See Example 1.

- |   |   |
|---|---|
| 21. Express $\frac{3\pi}{2}$ in degrees.  | 22. Express $-\frac{9\pi}{4}$ in degrees. |
| 23. Express $3\pi$ in degrees.            | 24. Express $\frac{\pi}{12}$ in degrees.  |
| 25. Express $-\frac{2\pi}{5}$ in degrees. | 26. Express $\frac{2\pi}{3}$ in degrees.  |
| 27. Express $20^\circ$ in radians.        | 28. Express $340^\circ$ in radians.       |
| 29. Express $-144^\circ$ in radians.      | 30. Express $66^\circ$ in radians.        |
| 31. Express $30^\circ$ in radians.        | 32. Express $180^\circ$ in radians.       |

The unit circle shown below shows several angles in radians or degrees. Fill in the corresponding radian or degree measure for Exercises 33–44.

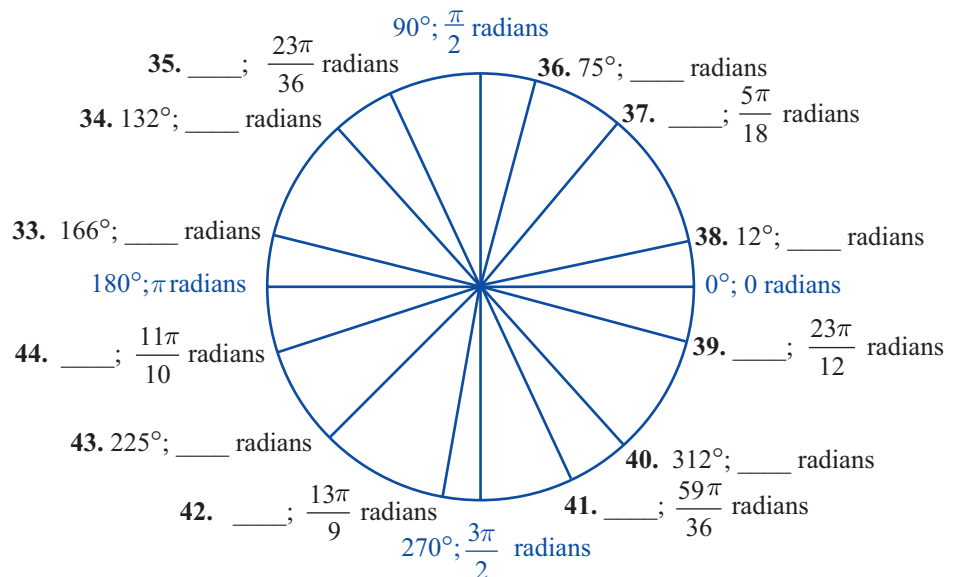

Use the information in each diagram to determine the radian measure of the indicated angle. See Example 2.

45.

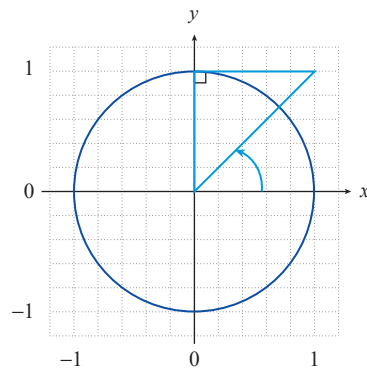

46.

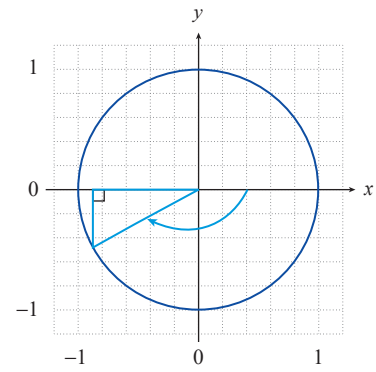

47.

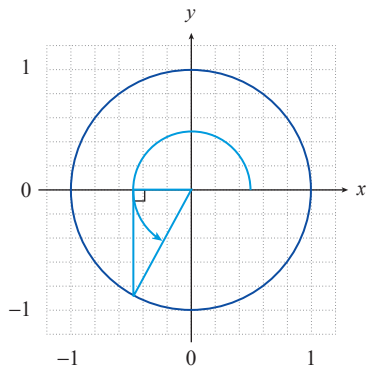

48.

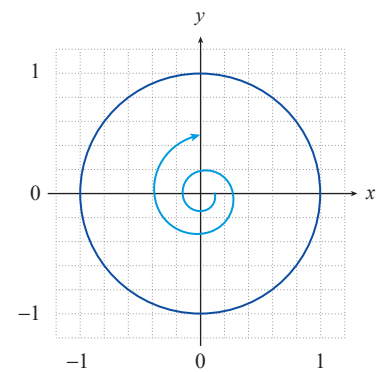

49.

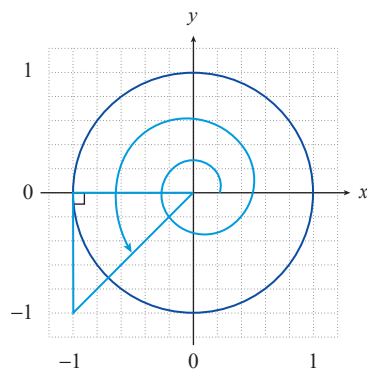

50.

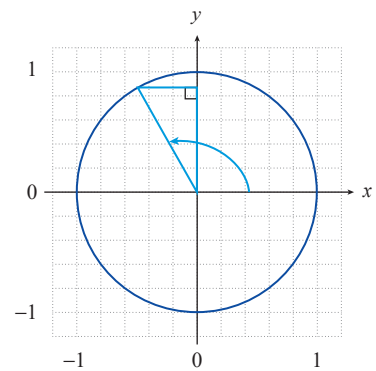

Sketch the indicated angles. See Example 2.

51.  $\frac{5\pi}{2}$

52.  $-60^\circ$

53.  $210^\circ$

54.  $-\frac{\pi}{3}$

55.  $\frac{7\pi}{4}$

56.  $120^\circ$

Find the length of the arc subtended by the given central angle  $\theta$  on a circle of radius  $r$ . Round your answers to two decimal places.

57.  $r = 4$  in.;  $\theta = 1$

58.  $r = 9$  cm;  $\theta = \frac{\pi}{2}$

59.  $r = 15$  ft;  $\theta = \frac{\pi}{4}$

60.  $r = 80$  km;  $\theta = 180^\circ$

61.  $r = 16.5$  m;  $\theta = 30^\circ$

62.  $r = 7$  ft;  $\theta = 90^\circ$

Find the radian measure of the central angle  $\theta$  given the radius  $r$  and the length  $s$  of the arc subtended by  $\theta$ . Leave your answers in fraction form.

63.  $r = 14$  ft;  $s = 63$  ft

64.  $r = 16$  in.;  $s = 6$  in.

65.  $r = 23.5$  dm;  $s = 10.5$  dm

66.  $r = 13$  cm;  $s = 130$  cm

67.  $r = 2$  km;  $s = 22.5$  km

68.  $r = 33$  ft;  $s = 11$  ft

### APPLICATIONS

Find the indicated arc length in each of the following problems. Round your answers to two decimal places. See Example 3.

69. Given a circle of radius 5 inches, find the length of the arc subtended by a central angle of  $17^\circ$  (**Hint:** Convert to radians first).

70. Given a circle of radius 22.5 cm, find the length of the arc subtended by a central angle of  $3\pi$ .

71. Given a circle with a diameter of 6 feet, find the length of the arc subtended by a central angle of  $68^\circ$  (**Hint:** Convert to radians first).

72. Given a circle of radius 7 m, find the length of the arc subtended by a central angle of  $\frac{7\pi}{8}$ .

73. A fly walking around the edge of a circular table 6 feet in diameter subtends a central angle of  $35^\circ$ . What distance does the fly walk?

74. Assuming that Columbia, SC and Daytona Beach, FL have the same longitude ( $81^\circ$  W), use a radius of 6370 km for Earth and the following to find the distance between the two cities.

| City              | Latitude        |
|-------------------|-----------------|
| Columbia, SC      | $34^\circ$ N    |
| Daytona Beach, FL | $29.25^\circ$ N |

75. Given that two cities on the equator are 100 miles apart and have the same latitude (that is, one is due west of the other), what is the difference in their longitudes? Use a value of 3960 miles for the radius of Earth.

76. Using a radius of 1.2 cm for the average eyeball, find the degree measure of the central angle formed to meet the edges of an iris (the colored portion of the eye) with an arc length of 9 mm.

77. Find the distance between Denver, CO and Roswell, NM which lie on the same longitude. The latitude of Denver is  $39.75^\circ$  N and the latitude of Roswell is  $33.3^\circ$  N. Use a radius of 3960 miles for Earth.

78. Find the distance between Atlanta, Georgia and Cincinnati, Ohio which lie on the same longitude. The latitude of Atlanta is  $33.67^\circ$  N and the latitude of Cincinnati is  $39.17^\circ$  N. Assume Earth's radius is 6370 km.

79. Find the distance between Greenwich, England and Valencia, Spain which lie on the same longitude. The latitude of Greenwich is  $51.48^\circ$  N and the latitude of Valencia is  $39.47^\circ$  N. Assume Earth's radius is 6370 km.
80. Find the distance between La Paz, Bolivia and Caracas, Venezuela which lie on the same longitude. The latitude of La Paz is  $16.50^\circ$  S and the latitude of Caracas is  $10.52^\circ$  N. Assume Earth's radius is 6370 km.
81. Find the distance between Bucharest, Romania and Johannesburg, South Africa which lie on the same longitude. The latitude of Bucharest is  $44.43^\circ$  N and the latitude of Johannesburg is  $26.21^\circ$  S. Assume Earth's radius is 6370 km.

The following problems ask you to determine the angular and/or linear speeds of various objects. Round your answers to two decimal places. See Example 4.

82. An industrial circular saw blade has a 10-inch radius and spins at 1000 rpm. Find  
**a.** the angular speed of a tooth of the blade in radians per minute and **b.** the linear speed of the tooth in feet per second.
83. Earth takes roughly 23 hours and 56 minutes to rotate once about its axis. Using a radius for Earth of 3960 miles, what is the linear speed in miles per hour (relative to the center of Earth) of a person standing on the equator? (Ignore, for the purposes of this problem, such motion as the rotation of Earth about the sun.)
84. A stationary exercise bike is ridden at a constant speed, causing the wheel to spin at a rate of 50 revolutions per minute. If a tack becomes lodged in the tire of radius 14 inches, find **a.** the angular speed of the tack in radians per minute and **b.** the linear speed of the tack in feet per minute.
85. A horse is tethered and urged to trot such that it completes a circular path every 5 seconds. If the rope which tethers it is 20 feet long, what is the linear speed of the horse in miles per hour?
86. The wheels of a certain bike are 28 inches in diameter. If the wheels are rotating at 210 revolutions per minute, how fast is the bicycle moving in miles per hour?
87. The floppy disk drive (FDD) was invented in 1967 to store information for computer users. The first floppy drive used an 8-inch disk and had a radius of 3.91 inches. The drive motor would spin at 300 rotations per minute (RPM).  
**a.** Find the angular speed of the 8-inch disk in radians per second.  
**b.** Find the linear speed of a particular point on the circumference of the 8-inch disk in inches per second.
88. The 8-inch floppy disk drive evolved into a smaller 5.25-inch disk that was used in the personal computers (PC) in the early 1980s. The 5.25-inch disk had a radius of 2.53 in. The usual drive motor for the 5.25-inch disk would spin at 360 rotations per minute.  
**a.** Find the angular speed of the 5.25-inch disk in radians per second.  
**b.** Find the linear speed of a particular point on the circumference of the 5.25-inch disk in inches per second.

Exercises 89–100 ask you to calculate the area of a sector of a circle. Round your answers to two decimal places. See Example 5.

89. Find the area of the shaded portion of the circle.

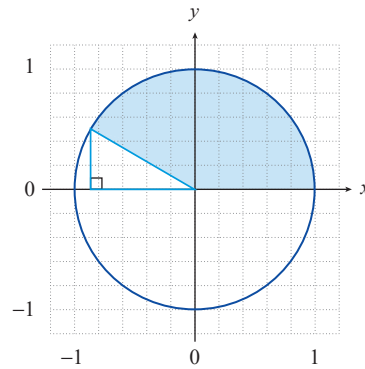

90. Find the area of the shaded portion of the circle.

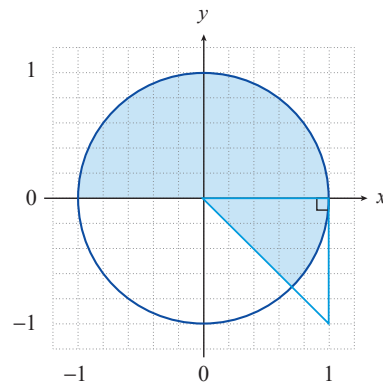

91. Find the area of the sector of a circle of radius 7 cm with a central angle of  $70^\circ$ .

92. Find the area of the sector of a circle of radius 3.5 ft with a central angle of  $27^\circ$ .

93. Find the area of the sector of a circle of radius 4 m with a central angle of  $\frac{3\pi}{5}$ .

94. Find the area of the sector of a circle of radius 16 in. with a central angle of  $138^\circ$ .

95. Find the area of the sector of a circle of radius 20 ft with a central angle of  $\frac{\pi}{2}$ .

96. Find the area of the sector of a circle of radius 19 km with a central angle of  $5.31^\circ$ .

97. A pie of radius 5 in. is cut into 8 equal pieces. What is the area of each piece?

98. The minute hand of a clock extends out to the edge of the clock's face, which is a circle of radius 2 in. What area does the minute hand sweep out between 9:05 and 9:25?

99. The circular spinner for a board game is divided into 6 equal wedges, each of a different color. If the radius is 5 cm, what area is encompassed by 2 wedges?

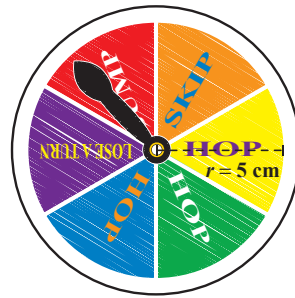

100. A lawn sprinkler throws water over a distance of 20 ft. If it rotates back and forth through an angle of  $50^\circ$ , what is the area of the region it waters?
101. Two gears are rotating to turn a conveyor belt. The smaller gear rotates  $80^\circ$  as the larger gear rotates  $50^\circ$ . If the larger gear has a radius of 18.7 in., what is the radius of the smaller gear?
102. Two water mills are on display at a local museum. The smaller water mill rotates counterclockwise and turns the larger water mill in a clockwise direction. If the smaller water mill has a radius of 5.23 ft and the larger water mill has a radius of 8.16 ft, what is the degree of rotation of the larger wheel when the smaller rotates  $60^\circ$ ?

**Solution**

Using the notation of the derivation above, we are given  $\alpha = 60^\circ 1' 6''$ ,  $\beta = 56^\circ 3' 23''$ , and  $d = 1000$ . Converting to decimal notation,  $\alpha \approx 60.018333^\circ$  and  $\beta \approx 56.056389^\circ$ , so we calculate the approximate height of Mt. Baldy as follows.

$$\begin{aligned} h &= \frac{1000}{\cot(56.056389^\circ) - \cot(60.018333^\circ)} \\ &\approx \frac{1000}{0.673078 - 0.576924} \\ &\approx 10,400 \text{ feet} \end{aligned}$$

**7.2 EXERCISES****PRACTICE**

Use the information contained in each figure to determine the values of the six trigonometric functions of  $\theta$ . Rationalize all denominators in your answers. See Example 1.

1.

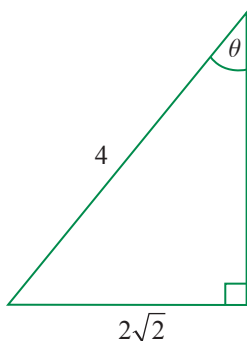

2.

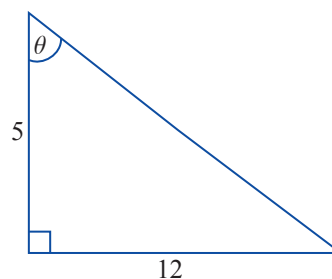

3.

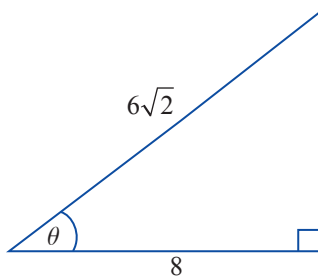

4.

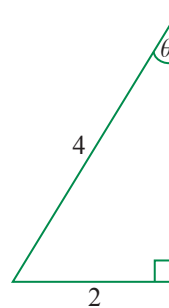

5.

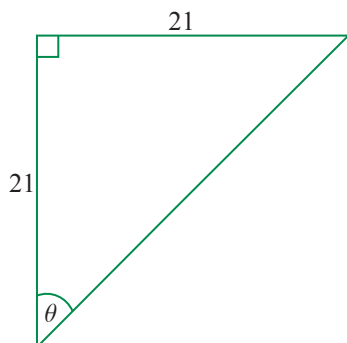

6.

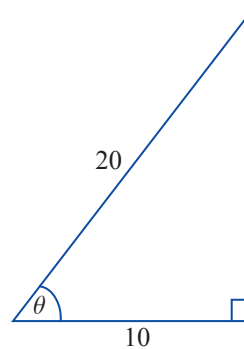

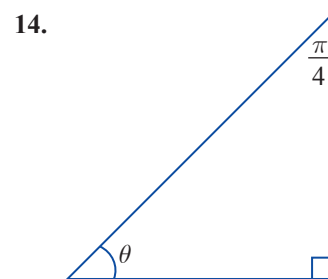
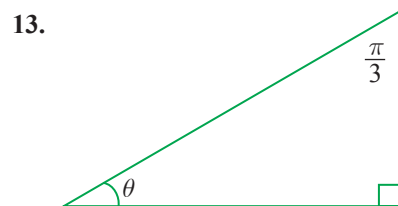
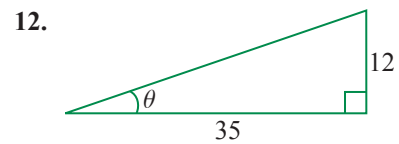
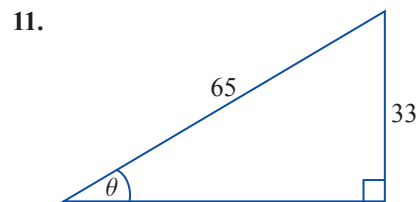
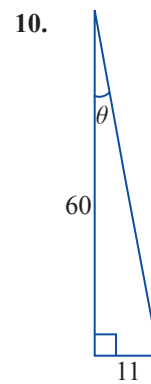
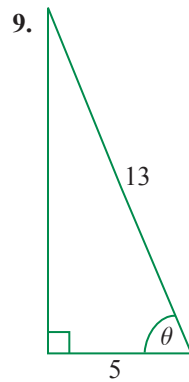
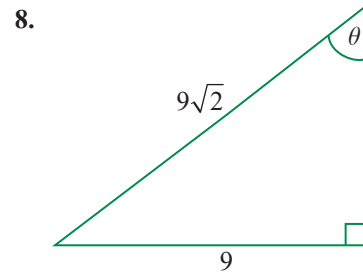
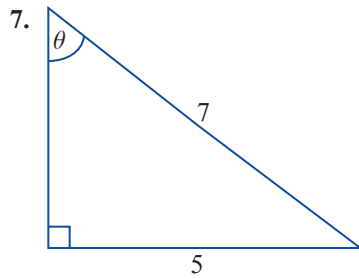

Evaluate the expressions, using a calculator if necessary. Rationalize all denominators in your answers. See Examples 2 and 3.

15. sine and cosecant of  $\frac{\pi}{4}$

16. cosine and tangent of  $\frac{\pi}{7}$

17.  $\sec 60^\circ$

18.  $\tan 71^\circ$  and  $\cot 71^\circ$

19.  $\csc\left(\frac{\pi}{6}\right)$

20. sine of  $\frac{3\pi}{7}$

21. secant and tangent of  $5^\circ$

22. cosine of  $28.37^\circ$

23. cotangent of  $\frac{\pi}{3}$

24.  $\sin\left(\frac{2\pi}{5}\right)$  and  $\cos\left(\frac{2\pi}{5}\right)$

25.  $\tan 87.2^\circ$

26.  $\csc 54^\circ$

Use a calculator to evaluate each of the following expressions. Round your answers to four decimal places. See Example 3.

27.  $\sin 84^\circ$       28.  $\cos 72^\circ$       29.  $\tan 46^\circ$       30.  $\csc 17^\circ$   
 31.  $\sec 88^\circ$       32.  $\cot 59^\circ$       33.  $\tan\left(\frac{2\pi}{5}\right)$       34.  $\cos\left(\frac{\pi}{4}\right)$   
 35.  $\sin\left(\frac{\pi}{8}\right)$       36.  $\cot\left(\frac{2\pi}{7}\right)$       37.  $\sec\left(\frac{\pi}{3}\right)$       38.  $\csc\left(\frac{5\pi}{11}\right)$

Convert each expression from degrees, minutes, seconds (DMS) notation to decimal notation. Round your answers to four decimal places.

39.  $38^\circ 54' 19''$       40.  $56^\circ 12' 1''$       41.  $25^\circ 18' 90''$   
 42.  $6^\circ 8' 50''$       43.  $21^\circ 39' 56''$       44.  $88^\circ 30' 600''$

Determine the value of the given trigonometric expression given the value of another trigonometric expression. Round your answers to four decimal places.

45. Find  $\sin \theta$  if  $\csc \theta = 8.7$ .      46. Find  $\cos \theta$  if  $\sec \theta = -\frac{7}{4}$ .  
 47. Find  $\tan \theta$  if  $\cot \theta = \frac{\sqrt{15}}{3}$ .      48. Find  $\cot \theta$  if  $\tan \theta = 2.5$ .  
 49. Find  $\sec \theta$  if  $\cos \theta = 0.2$ .      50. Find  $\csc \theta$  if  $\sin \theta = -\frac{1}{5}$ .

Determine whether the following statements are true or false. Use a calculator when necessary.

51. If  $\sin \theta = 0.8$ , then  $\csc \theta = 1.25$ .      52. If  $\cos \theta = 0.96$ , then  $\sec \theta = 1\frac{1}{24}$ .  
 53. If  $\tan \theta = 4\frac{4}{9}$ , then  $\cot \theta = 0.225$ .      54. If  $\sin \theta = 0.5625$ , then  $\csc \theta = 2.48$ .  
 55. If  $\cos \theta = 0.75$ , then  $\sec \theta = \frac{8}{3}$ .      56. If  $\tan \theta = 0.2540$ , then  $\cot \theta = 3.937$ .

### APPLICATIONS

Use an appropriate trigonometric function and a calculator if necessary to solve each of the following problems. Round your answers to two decimal places. See Examples 4 and 5.

57. A hang glider wants to determine if a certain vertical cliff is a suitable height for her liftoff. From a distance of 40 yards, she measures the angle from the ground to the cliff's tip as  $88^\circ 55' 24''$ . How high is the cliff in feet?  
 58. A mahi-mahi is hooked on 70 feet of fishing line, 10 feet of which is above the surface of the water. The angle of depression from the water's surface to the line is  $40^\circ$ . How deep is the fish?  
 59. A filing cabinet is 3 feet and 4 inches tall from the floor. If a piece of string is stretched from the top of the cabinet to a point on the floor, and the angle between the string and the floor is  $11^\circ$ , what is the length of the string?

60. A tree being cut down makes a  $70^\circ$  angle with the ground when the tip of the tree is directly above a spot that is 40 feet from the base of the tree. Find the height of the tree.
61. Stephen is standing 15 yards from a stream, but instead of walking directly towards the stream, he decides to take a more scenic (though straight-line) path to the stream. If the angle between the scenic route and the stream is  $18^\circ$ , how far did Stephen walk?
62. The builder of a parking garage wants to build a ramp at an angle of  $16^\circ$  that covers a horizontal span of 40 feet. What is the vertical rise of the ramp?
63. A kitesurfer's lines are 20 m long and make an angle of  $37^\circ$  with the ocean while heading away from the beach under current wind conditions. How high above the water is the kite flying?
64. An anthropologist studying a tribe of indigenous people wants to know the dimensions of their stone-hewn temple. After walking 15 m from the structure, she measures the angle to its top to be  $53^\circ$ . What is the height of the temple?
65. A radio tower has a 64-foot shadow cast by the sun. If the angle from the tip of the shadow to the top of the tower is  $78.5^\circ$ , what is the height of the radio tower?
66. A ladder is propped up to a barn at an  $80^\circ$  angle. If the ladder is 22 feet long, what is the approximate height where the top of the ladder touches the barn?
67. The ramp of a moving truck touches the ground 12 feet away from the end of the truck. If the ramp makes an angle of  $30^\circ$  relative to the ground, what is the length of the ramp?
68. The angle of elevation of a flying kite is  $61^\circ 7' 21''$ . If the other end of the 40-foot string attached to the kite is tied to the ground, what is the approximate height of the kite?
69. A length of rope is attached from the top of a dock to the rope tie device located on the underside of the boat at the water's surface. The rope is 33 feet in length and has an angle of elevation relative to the surface of the water of  $12^\circ$ . How high above the water does the dock sit?

In Exercises 70–74, use the formula from Example 6.

70. A surveyor wants to find the width of a river without crossing it. He sights an abandoned tire on the opposite bank (the banks are straight and parallel) and measures the angle from where he stands relative to the shore to be  $31^\circ$ . After walking precisely 15 feet away from the tire, he measures the same angle to be  $13.5^\circ$ . How wide is the river?

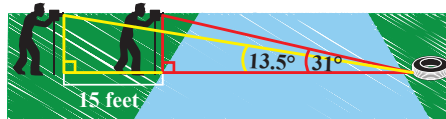

71. A drawbridge operator in a control room observes a sailboat approaching and finds the angle of depression to the boat to be  $9^\circ$ . Twenty minutes later, the angle to the same boat is  $19^\circ$ . If the sailboat has traveled 68.2 m, how high above water is the control room?
72. A birdwatcher discovers a hawk's nest in a tree some distance away. She wants to determine its height, so she measures the angle from the level ground to the nest at  $40^\circ$ . After approaching 25 feet closer to the tree, she finds the same angle to be  $52.5^\circ$ . How high does the nest sit, in feet?
73. A surveyor standing some distance from a plateau measures the angle of elevation from the ground to the top of the plateau to be  $46^\circ 57' 12''$ . The surveyor then walks forward 800 feet and measures the angle of elevation to be  $55^\circ 37' 70''$ . What is the height of the plateau?
74. A surveyor standing some distance from a hill measures the angle of elevation from the ground to the top of the hill to be  $83^\circ 45' 97''$ . The surveyor then steps back 300 feet and measures the angle of elevation to be  $75^\circ 44' 16''$ . What is the height of the hill?

 WRITING & THINKING

75. To physically demonstrate how the trigonometric functions are defined in terms of ratios of sides of a triangle, Adam draws the triangle shown. Belinda draws another triangle, beginning with the same angle but then proceeding to make her triangle significantly larger, also shown. Nevertheless, when Adam measures the lengths of his triangle's sides and calculates the values of all six trigonometric functions for the angle, and Belinda does the same for her triangle, they obtain the same results. What explains this outcome?

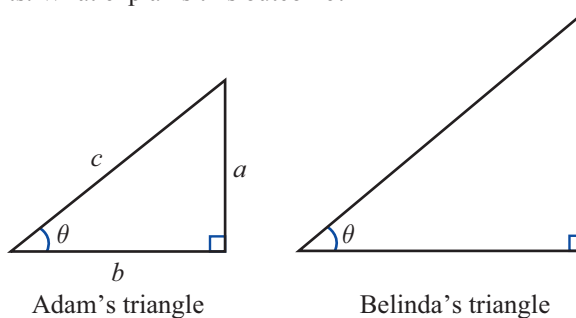

What we were not given initially is the length labeled  $y$  and the actual angle  $\theta$ . But from Figure 16, we can now recognize that the triangle is a familiar one and that  $\theta' = \frac{\pi}{6}$ , so  $\theta = \frac{5\pi}{6}$ . Finally, it must be the case that  $y = 1$ , and therefore  $\tan \theta = -\frac{1}{\sqrt{3}}$ .

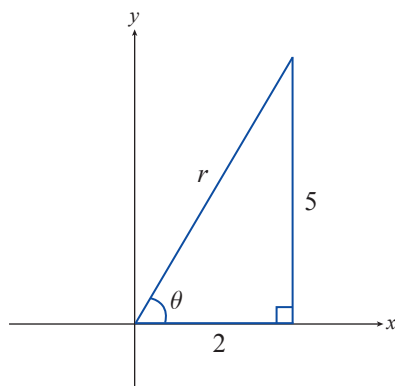

FIGURE 17

### Example 8: Using the Relationships between Trigonometric Functions

Given that  $\cot \theta = 0.4$  and  $\theta$  lies in the first quadrant, determine  $\sin \theta$ .

#### Solution

All trigonometric functions are ratios, so it will probably be useful to express cotangent as a fraction. The result will help us construct a right triangle that relates to the given information. To that end, note that  $\cot \theta = 0.4 = \frac{4}{10} = \frac{2}{5}$ . If we take the numerator and denominator as the lengths of the adjacent and opposite sides of a right triangle, we are led to the diagram in Figure 17.

Now we can use the Pythagorean Theorem to determine that  $r = \sqrt{4 + 25} = \sqrt{29}$ , and so  $\sin \theta = \frac{5}{\sqrt{29}}$ .

## 7.3 EXERCISES

### 💡 PRACTICE

Determine the point  $(x, y)$  on the unit circle associated with each real number  $s$ . See Example 1.

- |                         |                    |                          |
|-------------------------|--------------------|--------------------------|
| 1. $s = \frac{\pi}{6}$  | 2. $s = 225^\circ$ | 3. $s = -120^\circ$      |
| 4. $s = -\frac{\pi}{4}$ | 5. $s = \pi$       | 6. $s = -\frac{8\pi}{3}$ |
| 7. $s = -750^\circ$     | 8. $s = 855^\circ$ | 9. $s = \frac{31\pi}{6}$ |

Determine all real numbers  $s$  associated with each point  $(x, y)$  on the unit circle. See Example 2.

- |  |   |
|--|---|
| 10. $(x, y) = \left(-\frac{1}{\sqrt{2}}, -\frac{1}{\sqrt{2}}\right)$ | 11. $(x, y) = \left(\frac{1}{2}, -\frac{\sqrt{3}}{2}\right)$  |
| 12. $(x, y) = (0, -1)$   | 13. $(x, y) = \left(-\frac{\sqrt{3}}{2}, -\frac{1}{2}\right)$ |

Determine the values of the six trigonometric functions of each angle  $\theta$ , using a calculator and rounding your answers to four decimal places if necessary. See Examples 3, 4, and 5.

- |                               |                               |                           |
|-------------------------------|-------------------------------|---------------------------|
| 14. $\theta = 45^\circ$       | 15. $\theta = \frac{\pi}{2}$  | 16. $\theta = 60^\circ$   |
| 17. $\theta = \frac{3\pi}{4}$ | 18. $\theta = \frac{5\pi}{2}$ | 19. $\theta = -520^\circ$ |
| 20. $\theta = 305^\circ$      | 21. $\theta = -1105^\circ$    | 22. $\theta = 6\pi$       |
| 23. $\theta = 670^\circ$      | 24. $\theta = \frac{3\pi}{2}$ | 25. $\theta = -215^\circ$ |
| 26. $\theta = \frac{5\pi}{4}$ | 27. $\theta = 780^\circ$      | 28. $\theta = -445^\circ$ |

Determine the reference angle associated with the given angle. See Example 4.

- |                               |                               |                               |
|-------------------------------|-------------------------------|-------------------------------|
| 29. $\theta = 98^\circ$       | 30. $\theta = \frac{9\pi}{2}$ | 31. $\theta = -60^\circ$      |
| 32. $\theta = \frac{5\pi}{4}$ | 33. $\theta = \frac{5\pi}{2}$ | 34. $\theta = 313^\circ$      |
| 35. $\theta = \frac{7\pi}{6}$ | 36. $\theta = -168^\circ$     | 37. $\theta = \frac{6\pi}{5}$ |
| 38. $\theta = 216^\circ$      | 39. $\theta = \frac{3\pi}{2}$ | 40. $\theta = -330^\circ$     |
| 41. $\theta = \frac{7\pi}{4}$ | 42. $\theta = 718^\circ$      | 43. $\theta = 105^\circ$      |

Determine the quadrant in which the terminal side of the angle  $\theta$  is located.

- |   |   |
|---|---|
| 44. $\sin \theta > 0$ and $\tan \theta < 0$ | 45. $\sin \theta < 0$ and $\cot \theta > 0$ |
| 46. $\tan \theta > 0$ and $\sec \theta > 0$ | 47. $\cos \theta > 0$ and $\cot \theta < 0$ |
| 48. $\sec \theta < 0$ and $\csc \theta < 0$ | 49. $\cot \theta > 0$ and $\csc \theta > 0$ |
| 50. $\cot \theta > 0$ and $\cos \theta < 0$ | 51. $\sin \theta > 0$ and $\sec \theta < 0$ |

In Exercises 52–61, match the given angle  $\theta$  with the correct reference angle  $\theta'$  among the answer choices **a.**–**c.** Answers will be used more than once.

**a.**  $\theta' = 30^\circ$    **b.**  $\theta' = 45^\circ$    **c.**  $\theta' = 60^\circ$

- |                           |                          |                           |                          |
|---------------------------|--------------------------|---------------------------|--------------------------|
| 52. $\theta = 300^\circ$  | 53. $\theta = 150^\circ$ | 54. $\theta = -135^\circ$ | 55. $\theta = 210^\circ$ |
| 56. $\theta = -120^\circ$ | 57. $\theta = 315^\circ$ | 58. $\theta = 510^\circ$  | 59. $\theta = 600^\circ$ |
| 60. $\theta = 855^\circ$  | 61. $\theta = 480^\circ$ |                           |                          |

In Exercises 62–76, **a.** rewrite the expression in terms of the given angle's reference angle, and then **b.** evaluate the result, using a calculator and rounding your answers to four decimal places if necessary. See Example 5.

- |                                       |                                       |                       |
|---------------------------------------|---------------------------------------|-----------------------|
| 62. $\tan 98^\circ$                   | 63. $\sin\left(\frac{9\pi}{2}\right)$ | 64. $\cos(-60^\circ)$ |
| 65. $\tan\left(\frac{5\pi}{4}\right)$ | 66. $\cos\left(\frac{5\pi}{2}\right)$ | 67. $\sin 313^\circ$  |

68.  $\cos\left(\frac{7\pi}{6}\right)$       69.  $\tan(-168^\circ)$       70.  $\cos\left(\frac{6\pi}{5}\right)$   
 71.  $\sin 216^\circ$       72.  $\tan\left(\frac{3\pi}{2}\right)$       73.  $\cos(-330^\circ)$   
 74.  $\sin\left(\frac{7\pi}{4}\right)$       75.  $\tan 718^\circ$       76.  $\sin 105^\circ$

Use the appropriate identity to answer each of the following questions. Choose only one answer per question.

77. Which choice is equivalent to  $\sin 18^\circ$ ?  
 a.  $\tan 72^\circ$       b.  $\cos 72^\circ$       c.  $\csc 72^\circ$       d.  $\sec 162^\circ$       e.  $\cos 162^\circ$
78. Which choice is equivalent to  $\sec\left(\frac{\pi}{6}\right)$ ?  
 a.  $\csc\left(\frac{\pi}{3}\right)$       b.  $\cos\left(\frac{\pi}{2}\right)$       c.  $\sin\left(\frac{\pi}{6}\right)$       d.  $\cos\left(\frac{\pi}{3}\right)$       e.  $\tan\left(\frac{\pi}{6}\right)$
79. Which choice is equivalent to  $\tan\left(\frac{\pi}{12}\right)$ ?  
 a.  $\sin\left(\frac{\pi}{2}\right)$       b.  $\cos\left(\frac{\pi}{12}\right)$       c.  $\cot\left(\frac{\pi}{2}\right)$       d.  $\cot\left(\frac{\pi}{12}\right)$       e.  $\cot\left(\frac{5\pi}{12}\right)$
80. Which choice is equivalent to  $\cos 87^\circ$ ?  
 a.  $\sin 93^\circ$       b.  $\cos 93^\circ$       c.  $\sin 273^\circ$       d.  $\sec 3^\circ$       e.  $\sin 3^\circ$

Express each of the following in terms of the appropriate cofunction, and verify the equivalence of the two expressions, using a calculator and rounding your answers to four decimal places if necessary. See Example 6.

81.  $\cot 135^\circ$       82.  $\sec\left(\frac{\pi}{2}\right)$       83.  $\sin(-60^\circ)$   
 84.  $\cos\left(-\frac{3\pi}{4}\right)$       85.  $\csc\left(\frac{5\pi}{6}\right)$       86.  $\cot 313^\circ$   
 87.  $\cos\left(-\frac{3\pi}{6}\right)$       88.  $\csc(-168^\circ)$       89.  $\sin\left(-\frac{4\pi}{5}\right)$   
 90.  $\sec 216^\circ$       91.  $\csc\left(\frac{3\pi}{2}\right)$       92.  $\cos(-15^\circ)$   
 93.  $\cot\left(\frac{\pi}{4}\right)$       94.  $\tan(-105^\circ)$       95.  $\sec 105^\circ$

Using a calculator, determine  $\tan \theta$  and  $\cot \theta$  for each of the following exercises. Round your answers to three decimal places.

96.  $\sin \theta = 0.978$  and  $\cos \theta = 0.208$       97.  $\sin \theta = 0.588$  and  $\cos \theta = -0.809$   
 98.  $\sin \theta = -0.966$  and  $\cos \theta = -0.259$       99.  $\sin \theta = -0.866$  and  $\cos \theta = -0.5$   
 100.  $\sin \theta = -0.699$  and  $\cos \theta = 0.743$       101.  $\sin \theta = -0.995$  and  $\cos \theta = -0.105$

Use the given information about each angle to evaluate the expressions, if possible. If no angle with the stated properties exists, determine the reason. See Examples 7 and 8.

102. Given that  $\cos \theta = \frac{\sqrt{12}}{4}$  and  $\tan \theta$  is negative, determine  $\theta$  and  $\tan \theta$ .
103. Given that  $\csc \theta = 1.25$  and the terminal side of  $\theta$  lies in the second quadrant, determine  $\cot \theta$ .
104. Given that  $\tan \theta = \frac{\sqrt{3}}{3}$  and  $\sin \theta$  is positive, determine  $\theta$  and  $\sin \theta$ .
105. Given that  $\sin \theta = 2$  and  $\theta$  is positive, determine  $\tan \theta$ .
106. Given that  $\cot \theta = \frac{3}{4}$  and  $\sin \theta$  is negative, determine  $\sec \theta$ .
107. Given that  $\sin \theta = \frac{\sqrt{3}}{2}$  and  $\theta$  lies in the second quadrant, determine  $\theta$  and  $\tan \theta$ .
108. Given that  $\sec \theta = 0.3$  and the terminal side of  $\theta$  lies in the fourth quadrant, determine  $\csc \theta$ .

The three cofunction identities presented in this section have three companion identities, as follows:

$$\sin \theta = \cos \left( \frac{\pi}{2} - \theta \right), \quad \sec \theta = \csc \left( \frac{\pi}{2} - \theta \right), \quad \text{and} \quad \tan \theta = \cot \left( \frac{\pi}{2} - \theta \right).$$

Express each of the following in terms of the appropriate cofunction. Evaluate both the given expression and the cofunction expression with your calculator to verify that the expressions are equivalent.

109.  $\sin \left( \frac{7\pi}{4} \right)$       110.  $\csc \left( \frac{8\pi}{3} \right)$       111.  $\cot \left( \frac{3\pi}{4} \right)$
112.  $\cos \left( -\frac{5\pi}{3} \right)$       113.  $\tan 15^\circ$       114.  $\sec(-315^\circ)$

### WRITING & THINKING

115. Prove the three cofunction identities given in the directions for Exercises 109–114. (**Hint:** For the first identity, begin with the observation that  $\sin \theta = \sin \left( \frac{\pi}{2} - \left( \frac{\pi}{2} - \theta \right) \right)$  and then apply one of the three original cofunction identities.)

### Example 9: Modeling Damped Harmonic Motion

Sketch the graph of  $f(t) = -4e^{-t} \cos(6\pi t)$ .

#### Solution

We've already graphed the function  $f(t) = -4 \cos(6\pi t)$  (this function was our simple model for the motion of the grocer's basket in Example 8). The factor of  $e^{-t}$  provides the desired damping effect. In Figure 17, the graphs of  $4e^{-t}$  and  $-4e^{-t}$  are included to show how they describe the “envelope” of amplitude modulation. The result is that the magnitude of the displacement of the grocer's basket decreases over time. Notice, however, the period is unaffected.

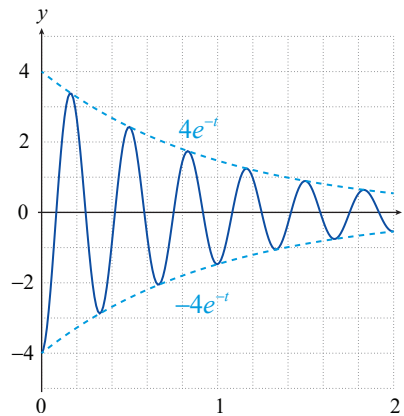

FIGURE 17

In the exercises to follow, you'll be asked to sketch graphs of similar products of damping factors and trigonometric functions.

## 7.4 EXERCISES

### 💡 PRACTICE

Determine the amplitude and frequency of each of the following functions. Then sketch one complete cycle of each function starting at  $x = 0$ . See Example 4.

1.  $f(x) = 2 \cos(2x)$

2.  $g(x) = -5 \sin(\pi x)$

3.  $g(x) = \frac{\sin(3x)}{2}$

4.  $f(x) = \frac{\cos\left(\frac{\pi x}{2}\right)}{3}$

Determine the amplitude, period, and phase shift of each of the following functions. See Examples 6 and 7.

5.  $f(x) = 2 \cos x$

6.  $g(x) = \frac{3}{2} \sin x$

7.  $f(x) = 5 + 4 \cos x$

8.  $f(x) = \sin(x - 5)$

9.  $h(x) = -\sin x$

10.  $h(x) = \frac{\cos x}{2}$

11.  $g(x) = -3 \cos(x + 7)$

12.  $f(x) = \frac{2}{3} \sin x$

13.  $f(x) = 2 \sin(2x)$

14.  $h(x) = -3 \cos\left(\frac{1}{2}x\right)$

15.  $g(x) = \frac{3 \sin(\pi\theta)}{2}$

16.  $g(x) = \cos(3\pi\theta - 2)$

17.  $f(x) = 0.5 \sin(8x + 1)$

18.  $h(x) = 7 \cos\left(x \cdot \frac{\pi}{2} + \frac{3}{2}\right)$

19.  $g(x) = \frac{8 \cos(2\pi x + 4)}{5}$

20.  $g(x) = 2 - \frac{3}{4} \sin(-3 + x)$

Sketch the graph of each of the following functions. See Examples 6 and 7.

21.  $f(x) = \cos(\pi x)$

22.  $g(x) = -2 \sin(5x)$

23.  $g(x) = 3 \sin(x - 2\pi)$

24.  $g(x) = \sin\left(x - \frac{\pi}{4}\right)$

25.  $f(x) = 4 \cos\left(\frac{3x}{2} + \frac{\pi}{2}\right)$

26.  $g(x) = 2 \cos(4x - 2)$

27.  $f(x) = \cos(x - \pi)$

28.  $g(x) = 3 \sin(4x)$

29.  $f(x) = -\sin(2\pi x)$

30.  $g(x) = 1 + \sin(x - 2\pi)$

31.  $f(x) = 2 - \cos(2\pi x)$

32.  $g(x) = 5 - 2 \sin\left(x - \frac{\pi}{2}\right)$

33.  $f(x) = -3 + 5 \cos x$

34.  $g(x) = 2 - \sin\left(2x - \frac{\pi}{4}\right)$

35.  $f(x) = \frac{1}{2} - 5 \sin\left(\frac{1}{2}x - \frac{\pi}{2}\right)$

36.  $g(x) = 1 - \frac{1}{4} \cos\left(\frac{1}{4}x - \frac{\pi}{2}\right)$

Sketch each of the following functions modeling damped harmonic motion. See Example 9.

37.  $g(t) = -2e^{-t} \cos(5\pi t)$

38.  $f(t) = e^{-t} \sin\left(\frac{3\pi}{4}t\right)$

39.  $g(t) = e^t \sin\left(3t - \frac{\pi}{2}\right)$

40.  $g(t) = 3e^{-t} \cos\left(5t - \frac{\pi}{2}\right)$

41.  $f(t) = -3 + 5e^{-t} \cos t$

42.  $f(t) = -5e^t \cos\left(\frac{3\pi}{2}t\right)$

43.  $f(t) = \frac{1}{2}e^{-t} \sin\left(\frac{5}{6}t - 4\pi\right) + 2$

44.  $g(t) = 2 + e^{-t} \sin\left(t - \frac{\pi}{4}\right)$

### APPLICATIONS

In Exercises 45–46, use the relationship between frequency and period to answer the question. See Example 5.

45. Many grandfather clocks have a pendulum that swings with a period of two seconds. What is the frequency of such a pendulum?
46. A heart rate of 1200 beats per minute (bpm) is typical for a hummingbird. What is the length of the period, in seconds, of such a heart rate?
47. A baby is playing with a toy attached above his head on a coiled spring. The baby pulls the toy down a distance of 3 inches from its equilibrium position, and then releases it. The time for one oscillation is 2 seconds. Find the amplitude and period, then give the function for its displacement.
48. A pull cord for a lighted ceiling fan is swinging back and forth. The end of the cord swings a total distance of 4 inches from end to end at an average speed of 9 inches per second. Find the period of oscillation.
49. Marcel is bouncing a basketball at an average speed of 10 ft/s with the ball coming up to his waist on each bounce. The distance from the ground to his waist is approximately 3 feet. Find the amplitude and period, then give the function for its displacement.
50. A leaf floating on the water of a perfectly calm pond is suddenly disturbed by a series of waves caused by a landing duck. At time  $t = 0$  seconds, the leaf initially bobs upward 5 centimeters, and then continues to oscillate up and down with a period of 2 seconds.
  - a. Find a function that models the simple harmonic motion described.
  - b. Assuming the amplitude of the waves diminishes over time by a factor of  $e^{\frac{-t}{5}}$ , modify your SHM model accordingly and graph the result.

 **WRITING & THINKING**

51. a. Find a transformation of cosine that shifts its graph to the left so as to coincide with the graph of sine.
- b. Using  $n$  to represent an arbitrary integer, find an expression that describes the infinite number of transformations of cosine that are equal to sine.
52. Prove the even and odd identities for the secant and cotangent functions.

We've now gained quite a lot of experience with the process of graphing transformed trigonometric functions. The periodic nature of trigonometric functions means, however, that the reverse process of identifying a function from its graph is not so clear cut, as our last example illustrates.

### Example 5: Identifying a Trigonometric Graph

Find a function corresponding to the graph shown in Figure 6.

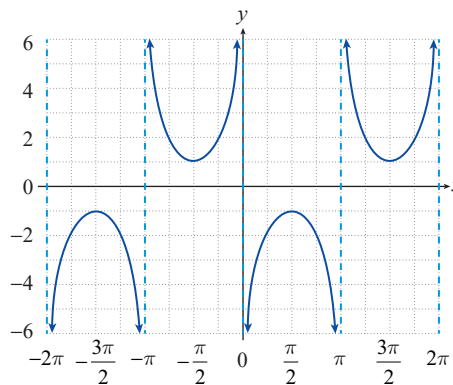

FIGURE 6

### Solution

The graph shown in Figure 6 is certainly similar to the graph of cosecant in many ways, but after a transformation of some sort. One such transformation that may come to mind is that the graph appears to be the reflection of cosecant with respect to the  $y$ -axis, which corresponds to replacing  $x$  with  $-x$  in the definition of the function. So the graph in Figure 6 could be of the function  $f(x) = \csc(-x)$ . However, someone else may look at the graph and see it as a horizontal shift to the left by  $\pi$  units of the graph of cosecant, which would be the function  $g(x) = \csc(x + \pi)$ . A third person may recognize it as the graph of cosecant reflected with respect to the  $x$ -axis, which would be the function  $h(x) = -\csc x$ . Once we recall that cosecant is an odd function, we remember that  $\csc(-x) = -\csc x$ , so we shouldn't be surprised that  $f$  and  $h$  are two possible functions corresponding to the given graph. In fact,  $f$ ,  $g$ , and  $h$  are just three of an infinite number of functions all having the graph in Figure 6.

## 7.5 EXERCISES

### 💡 PRACTICE

Sketch the graph of each of the following functions. See Examples 1 through 4.

1.  $f(x) = \csc\left(\frac{3\pi}{4}x\right)$

2.  $g(x) = \tan\left(3\pi x - \frac{\pi}{2}\right)$

3.  $g(x) = \frac{1}{3}\sec(2x)$

4.  $f(x) = -5\cot(\pi x)$

5.  $g(x) = \csc\left(\frac{3\pi}{2}x - \frac{1}{2}\right)$

6.  $g(x) = \cot\left(\frac{\pi x}{4}\right)$

7.  $f(x) = 5 \tan\left(3\pi - \frac{\pi}{2}x\right)$

8.  $f(x) = 4 + \csc\left(1 - \frac{5\pi}{4}x\right)$

9.  $f(x) = 1 - \cot\left(x - \frac{\pi}{2}\right)$

10.  $g(x) = 1 + \tan\left(\pi x - \frac{\pi}{4}\right)$

11.  $f(x) = 4 + \tan\left(x + \frac{3\pi}{2}\right)$

12.  $f(x) = 1 - 2 \sec(2\pi x)$

13.  $g(x) = 2 + \frac{5}{6} \sec\left(\frac{1}{2}x - \pi x\right)$

14.  $f(x) = \frac{1}{2} \tan\left(\frac{3}{4}x - 2\pi\right) + 3$

 **WRITING & THINKING**

15. Sketch the graph of the cotangent function, using each of the following approaches and noting how they produce the same result.
- Use the identity  $\cot x = \frac{\cos x}{\sin x}$ .
  - Use the identity  $\cot x = \frac{1}{\tan x}$ .
  - Use the identity  $\cot x = \tan\left(\frac{\pi}{2} - x\right)$  and the fact that tangent is an odd function.
16. Sketch the graph of the secant function, using each of the following approaches and noting how they produce the same result.
- Use the identity  $\sec x = \frac{1}{\cos x}$ .
  - Use the identity  $\sec x = \csc\left(\frac{\pi}{2} - x\right)$  and the fact that cosecant is an odd function.

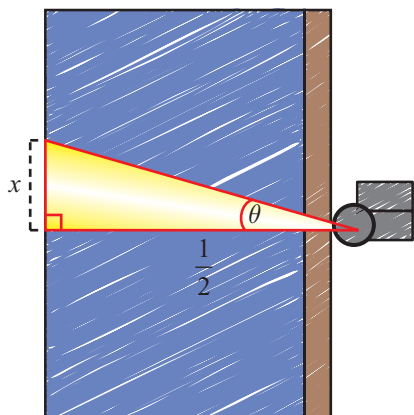

FIGURE 9

**Example 4: Using Inverse Trigonometric Functions**

A lighthouse is to be constructed half a mile from a long, straight reef, as shown in Figure 9. In order to ensure the light illuminates certain portions of the reef within specified lengths of time, the engineer needs a formula for  $\theta$  in terms of  $x$ . Find such a formula.

**Solution**

From Figure 9, we see that  $\tan \theta = \frac{x}{\frac{1}{2}} = 2x$ , so the formula for  $\theta$  is

$$\theta = \tan^{-1}(2x).$$

**Example 5: Using Inverse Trigonometric Functions**

Express  $\sin(\cos^{-1}(2x))$  as an algebraic function of  $x$ , assuming  $-\frac{1}{2} \leq x \leq \frac{1}{2}$ .

**Solution**

Let  $\theta = \cos^{-1}(2x)$ . Then  $\cos \theta = 2x$ , and we are led to consider a sketch like the one in Figure 10.

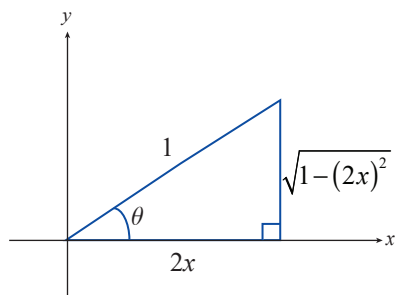

FIGURE 10

In the sketch, we have chosen the simplest lengths for the adjacent side and the hypotenuse that make  $\cos \theta = 2x$ , though any positive multiple of these lengths would also work. And as always, once the lengths of two sides of the right triangle have been determined, the Pythagorean Theorem provides the length of the third side. Now we can refer to the sketch to see that

$$\sin(\cos^{-1}(2x)) = \sin \theta = \frac{\sqrt{1-4x^2}}{1} = \sqrt{1-4x^2}.$$

**7.6 EXERCISES****PRACTICE**

Evaluate each of the following expressions without the use of a calculator. See Example 1.

- $\sin^{-1}(-1)$
- $\cos^{-1}\left(\frac{\sqrt{2}}{2}\right)$
- $\tan^{-1}1$
- $\cot^{-1}\left(-\frac{\sqrt{3}}{3}\right)$
- $\sec^{-1}\left(\frac{2\sqrt{3}}{3}\right)$
- $\csc^{-1}(-2)$
- $\arcsin 0$
- $\arccos(-1)$
- $\arctan(-\sqrt{3})$
- $\operatorname{arccot}(-\sqrt{3})$
- $\operatorname{arcsec} 2$
- $\operatorname{arccsc}(\sqrt{2})$
- $\operatorname{arccot}(-1)$
- $\tan^{-1}\left(\frac{\sqrt{3}}{3}\right)$
- $\cos^{-1}\left(-\frac{1}{2}\right)$
- $\csc^{-1} 2$

17.  $\arcsin\left(-\frac{1}{2}\right)$     18.  $\sec^{-1}(-1)$     19.  $\operatorname{arccsc} 1$     20.  $\arctan 0$
21.  $\sin^{-1}\left(\frac{\sqrt{2}}{2}\right)$     22.  $\arccos\left(-\frac{\sqrt{2}}{2}\right)$     23.  $\operatorname{arcsec}(-2)$     24.  $\cot^{-1}(-\sqrt{3})$

Evaluate each of the following expressions, if possible, using a calculator and rounding your answers to four decimal places if necessary.

25.  $\sin^{-1}(-0.2)$     26.  $\cos^{-1} 4$     27.  $\sin^{-1}(-0.9)$
28.  $\tan^{-1} 5$     29.  $\cos^{-1}(-0.4)$     30.  $\tan^{-1}(0.8)$

Some calculators are not equipped with arccosecant, arcsecant, and arccotangent buttons, but expressions involving these functions can still be evaluated. To evaluate, for example,  $\csc^{-1} x$ , let  $\theta = \csc^{-1} x$ . Then

$$\begin{aligned}\csc \theta &= x \\ \frac{1}{\sin \theta} &= x \\ \sin \theta &= \frac{1}{x} \\ \theta &= \sin^{-1}\left(\frac{1}{x}\right).\end{aligned}$$

This means that arccosecant, arcsecant, and arccotangent can all be evaluated using the following formulas.

$$\begin{aligned}\csc^{-1} x &= \sin^{-1}\left(\frac{1}{x}\right) \\ \sec^{-1} x &= \cos^{-1}\left(\frac{1}{x}\right) \\ \cot^{-1} x &= \tan^{-1}\left(\frac{1}{x}\right), \text{ with } \cot^{-1} 0 = \frac{\pi}{2}\end{aligned}$$

Use these formulas to evaluate each of the following expressions, if possible, using a calculator and rounding your answers to four decimal places if necessary.

31.  $\csc^{-1} 5$     32.  $\sec^{-1}(-0.5)$     33.  $\cot^{-1} 150$
34.  $\cot^{-1}(0.2)$     35.  $\csc^{-1}(-8.9)$     36.  $\sec^{-1} 2$

Evaluate each of the following expressions, if possible. See Example 2.

37.  $\cos^{-1}\left(\cos\left(\frac{2\pi}{4}\right)\right)$     38.  $\sin^{-1}\left(\sin\left(\frac{3\pi}{2}\right)\right)$     39.  $\tan(\tan^{-1}(0.5))$
40.  $\sin^{-1}\left(\sin\left(\frac{7\pi}{6}\right)\right)$     41.  $\cos(\cos^{-1}(-0.8))$     42.  $\tan^{-1}\left(\tan\left(\frac{5\pi}{4}\right)\right)$

Evaluate each of the following expressions, if possible, using a calculator and rounding your answers to four decimal places if necessary. See Example 3.

$$43. \sin(\arctan(0.4)) \quad 44. \sin^{-1}\left(\cos\left(\frac{3\pi}{2}\right)\right) \quad 45. \cos(\tan^{-1}(0.5))$$

$$46. \arcsin(\tan 1) \quad 47. \tan(\cos^{-1}(-0.8)) \quad 48. \tan^{-1}(\cos 5)$$

Find the value of each of the following expressions without using a calculator.

$$49. \sin(\arctan(\sqrt{3})) \quad 50. \cos(\sec^{-1}(-2))$$

$$51. \tan(\operatorname{arccot} 1) \quad 52. \csc\left(\arccos\left(-\frac{\sqrt{3}}{2}\right)\right)$$

$$53. \tan\left(\sin^{-1}\left(-\frac{\sqrt{2}}{2}\right)\right) \quad 54. \sec\left(\csc^{-1}\left(\frac{2\sqrt{3}}{3}\right)\right)$$

$$55. \cos(\cot^{-1}(-1)) \quad 56. \sec\left(\arcsin\left(-\frac{1}{2}\right)\right)$$

$$57. \cot(\operatorname{arcsec}(\sqrt{2})) \quad 58. \cot(\operatorname{arccsc}(-2))$$

$$59. \sin\left(\cos^{-1}\left(\frac{\sqrt{2}}{2}\right)\right) \quad 60. \sec\left(\tan^{-1}\left(-\frac{\sqrt{3}}{3}\right)\right)$$

$$61. \sec\left(\arccos\left(-\frac{\sqrt{2}}{2}\right)\right) \quad 62. \tan(\csc^{-1}(-2))$$

$$63. \sin(\operatorname{arcsec}(\sqrt{2})) \quad 64. \csc(\cot^{-1}(\sqrt{3}))$$

$$65. \cot\left(\sin^{-1}\left(-\frac{\sqrt{2}}{2}\right)\right) \quad 66. \cos\left(\arctan\left(-\frac{\sqrt{3}}{3}\right)\right)$$

Express each of the following functions as a purely algebraic function. See Example 5.

$$67. \tan(\cos^{-1} x) \quad 68. \cot\left(\sin^{-1}\left(\frac{2}{x}\right)\right) \quad 69. \sec(\tan^{-1}(3x))$$

$$70. \tan\left(\sin^{-1}\left(\frac{x}{\sqrt{x^2+3}}\right)\right) \quad 71. \sin(\sec^{-1} x) \quad 72. \cos\left(\tan^{-1}\left(\frac{x}{4}\right)\right)$$

Using a calculator, find the value of  $\theta$  in degrees. Remember to make sure your calculator is in the correct mode.

$$73. \theta = \sin^{-1}(0.74184113) \quad 74. \theta = \arctan(-0.258416)$$

$$75. \theta = \operatorname{arccsc}(1.847526) \quad 76. \theta = \sec^{-1}(-1.1224539)$$

$$77. \theta = \cot^{-1}(0.57496998)$$

Using a calculator, find the value of  $\theta$  in radians. Remember to make sure your calculator is in the correct mode.

78.  $\theta = \arccos(-0.1115598)$

79.  $\theta = \operatorname{arccot}(1.547773)$

80.  $\theta = \tan^{-1}(5.999999)$

81.  $\theta = \csc^{-1}(-1.333333)$

82.  $\theta = \arcsin(0.65937229)$

Sketch the graph of each of the following functions. Then graph the function using a graphing utility to check your answer.

83.  $f(x) = \sin^{-1}(x-3)$

84.  $f(x) = \sec^{-1}(2x)$

85.  $f(x) = \arctan\left(\frac{x}{2}\right)$

86.  $f(x) = 2\arccos x$

### APPLICATIONS

87. Kim is watching a space shuttle launch from an observation spot two miles away from the launch pad. Find the angle of elevation to the shuttle for each of the following heights. Round your answers to four decimal places.

a. 0.5 miles

b. 2 miles

c. 2.8 miles

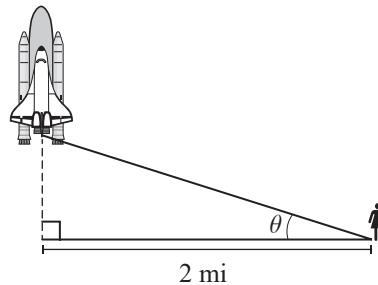

88. Jesse is rowing in the men's singles race. The length of the oar from the side of the shell to the water is 7 feet. At what angle is the oar from the side of the boat when the blade is at the following distance from the boat? Round your answers to four decimal places.

a. 2 feet

b. 3 feet

c. 5 feet

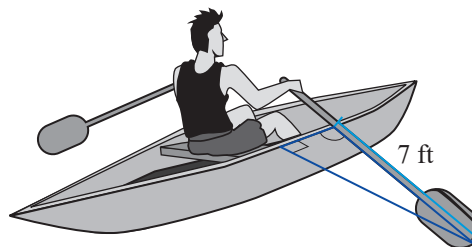

**Example 6: Using Trigonometric Substitutions**

Use the substitution  $\sin \theta = \frac{x}{2}$  to write  $\sqrt{4-x^2}$  as a trigonometric expression. Assume  $0 \leq \theta \leq \frac{\pi}{2}$ .

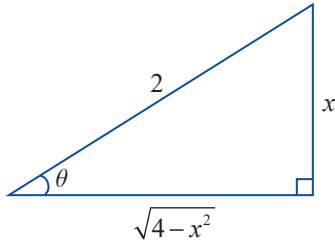
**FIGURE 3****Solution**

Although it is not necessary for the task at hand, a diagram motivating the substitution may be helpful. The triangle in Figure 3 illustrates the geometric relation between  $\theta$  and the various algebraic expressions.

The suggested substitution can be rewritten as  $x = 2 \sin \theta$ , and so we obtain the following.

$$\begin{aligned}\sqrt{4-x^2} &= \sqrt{4-(2\sin\theta)^2} \\ &= \sqrt{4-4\sin^2\theta} \\ &= 2\sqrt{1-\sin^2\theta} \\ &= 2\sqrt{\cos^2\theta} \\ &= 2\cos\theta\end{aligned}$$

We can write  $2\cos\theta$  instead of  $2|\cos\theta|$  since the restriction  $0 \leq \theta \leq \frac{\pi}{2}$  means  $\cos\theta \geq 0$ .

**8.1 EXERCISES****PRACTICE**

Use trigonometric identities to simplify the expressions. There may be more than one correct answer. See Examples 1 and 2.

- $\tan x \csc x$
- $\frac{1}{\tan^2 \theta + 1}$
- $\frac{\tan t}{\sec t}$
- $\cot^2 x - \cot^2 x \cos^2 x$
- $\sin(-x) \tan x$
- $\frac{1}{\sec^2 x} + \sin x \cos\left(\frac{\pi}{2} - x\right)$
- $\sin(\alpha + 2\pi) \sec \alpha$
- $\sin t (\csc t - \sin t)$
- $\cos y (1 + \tan^2 y)$
- $\frac{1}{\cos x \csc(-x)}$
- $\frac{1 - \tan^2 x}{\cot^2 x - 1}$
- $\frac{\sin \beta \tan\left(\frac{\pi}{2} - \beta\right)}{\cos \beta}$

Use the suggested substitution to rewrite the given expression as a trigonometric expression.

See Example 6. Assume  $0 \leq \theta \leq \frac{\pi}{2}$ .

13.  $\sqrt{x^2 + 1}$ ,  $x = \tan \theta$

14.  $\sqrt{x^2 - 16}$ ,  $x = 4 \sec \theta$

15.  $\sqrt{9 - x^2}$ ,  $\cos \theta = \frac{x}{3}$

16.  $\sqrt{4x^2 + 100}$ ,  $\cot \theta = \frac{x}{5}$

17.  $\sqrt{64 - x^2}$ ,  $x = 8 \sin \theta$

18.  $\sqrt{x^2 - 4}$ ,  $x = 2 \csc \theta$

19.  $\sqrt{x^2 + 25}$ ,  $\tan \theta = \frac{x}{5}$

20.  $\sqrt{144 - 9x^2}$ ,  $x = 4 \cos \theta$

### WRITING & THINKING

Verify the following trigonometric identities. See Examples 3, 4, and 5.

21.  $(1 - \cos \theta)(1 + \cos \theta) = \sin^2 \theta$

22.  $\csc x - \sin x = \cos x \cot x$

23.  $\sec^2 y - \tan^2 y = \sec y \cos(-y)$

24.  $(1 - \sin \beta)(\sec \beta \tan \beta) = \frac{\sin \beta}{1 + \sin \beta}$

25.  $\frac{\sin\left(\frac{\pi}{2} - x\right)}{\cos\left(\frac{\pi}{2} - x\right)} = \cot x$

26.  $\frac{\sec^2 \theta}{\tan \theta} = \sec \theta \csc \theta$

27.  $\frac{1}{\tan x} + \tan x = \frac{\sec^2 x}{\tan x}$

28.  $\sin^2 t + \sin^2\left(\frac{\pi}{2} - t\right) = 1$

29.  $\frac{1}{\sin(\theta + 2\pi) + 1} + \frac{1}{\csc(\theta + 2\pi) + 1} = 1$

30.  $3 + \cot^2 \alpha = 2 + \csc^2 \alpha$

31.  $\sin^2 x - \sin^4 x = \cos^2(-x) - \cos^4(-x)$

32.  $\cot\left(\frac{\pi}{2} - \beta\right) \cot \beta = 1$

33.  $\frac{\cos\left(\frac{\pi}{2} - \alpha\right)}{\csc \alpha} - 1 = \sin \alpha \cot(-\alpha) \cos(-\alpha)$

Show how the identities below follow from the first Pythagorean identity.

34.  $\tan^2 x + 1 = \sec^2 x$

35.  $1 + \cot^2 x = \csc^2 x$

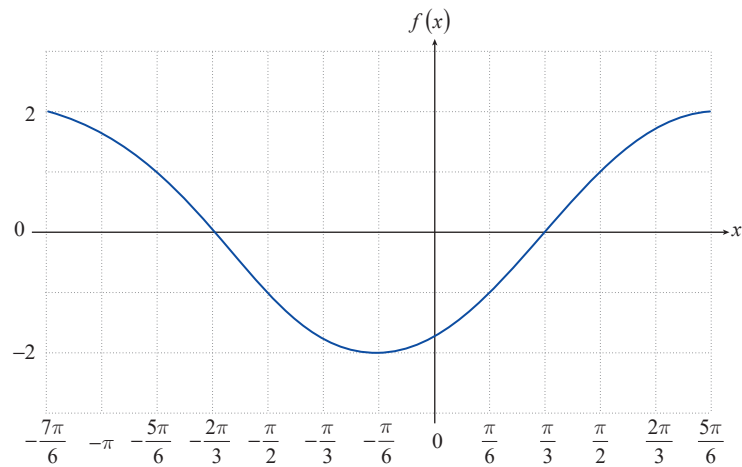

FIGURE 7:  $f(x) = 2\sin\left(x - \frac{\pi}{3}\right)$

## 8.2 EXERCISES

### PRACTICE

Use the sum and difference identities to determine the exact value of each of the following expressions. See Examples 1, 2, and 3.

1.  $\cos\left(\frac{\pi}{4} + \frac{\pi}{3}\right)$

2.  $\sin\left(\frac{\pi}{6} + \frac{3\pi}{4}\right)$

3.  $\tan\left(\frac{4\pi}{3} + \frac{5\pi}{4}\right)$

4.  $\sin\left(\frac{2\pi}{3} + \frac{\pi}{4}\right)$

5.  $\tan\left(\frac{\pi}{3} - \frac{3\pi}{4}\right)$

6.  $\tan\left(\frac{4\pi}{3} - \frac{5\pi}{4}\right)$

7.  $\cos\left(\frac{\pi}{4} - \frac{\pi}{6}\right)$

8.  $\sin\left(\frac{5\pi}{4} - \frac{\pi}{3}\right)$

9.  $\sin\left(\frac{7\pi}{4} + \frac{2\pi}{3}\right)$

10.  $\cos\left(\frac{\pi}{3} - \frac{\pi}{4}\right)$

11.  $\tan 75^\circ$

12.  $\tan 15^\circ$

13.  $\sin 165^\circ$

14.  $\cos(-15^\circ)$

15.  $\tan 255^\circ$

16.  $\cos 195^\circ$

17.  $\cos 165^\circ$

18.  $\sin\left(\frac{\pi}{12}\right)$

19.  $\tan\left(\frac{5\pi}{12}\right)$

20.  $\cos\left(\frac{7\pi}{12}\right)$

21.  $\cos\left(\frac{25\pi}{12}\right)$

22.  $\sin\left(\frac{13\pi}{12}\right)$

23.  $\sin\left(\frac{11\pi}{12}\right)$

24.  $\tan\left(\frac{7\pi}{12}\right)$

25.  $\sin\left(\frac{5\pi}{12}\right)$

26.  $\tan\left(\frac{\pi}{12}\right)$

27. Suppose that  $\sin \alpha = \frac{4}{5}$  and  $\sin \beta = \frac{5}{13}$  and both  $\alpha$  and  $\beta$  are in quadrant I. Find  $\cos(\alpha - \beta)$ .
28. Suppose that  $\sin \alpha = -\frac{15}{17}$  and  $\cos \beta = -\frac{3}{5}$  and the terminal sides of both  $\alpha$  and  $\beta$  are in quadrant III. Find  $\sin(\alpha - \beta)$ .
29. Suppose that  $\cos \alpha = -\frac{15}{17}$  and  $\cos \beta = -\frac{3}{5}$ , the terminal side of  $\alpha$  is in quadrant II, and the terminal side of  $\beta$  is in quadrant III. Find  $\sin(\alpha + \beta)$ .
30. Suppose that  $\cos \alpha = -\frac{24}{25}$  and  $\sin \beta = \frac{5}{13}$ , the terminal side of  $\alpha$  is in quadrant III, and  $\beta$  is in quadrant I. Find  $\cos(\alpha + \beta)$ .
31. Suppose that  $\cos \alpha = \frac{2}{5}$  and  $\cos \beta = \frac{1}{5}$  and both  $\alpha$  and  $\beta$  are in quadrant I. Find  $\sin(\beta - \alpha)$ .
32. Suppose that  $\cos \alpha = -\frac{2}{3}$  and  $\sin \beta = -\frac{2\sqrt{2}}{3}$ , the terminal side of  $\alpha$  is in quadrant III, and the terminal side of  $\beta$  is in quadrant IV. Find  $\tan(\alpha + \beta)$ .

Use the sum and difference identities to rewrite each of the following expressions as a trigonometric function of one angle, and then evaluate the result. See Example 4.

33.  $\sin 15^\circ \cos 30^\circ + \cos 15^\circ \sin 30^\circ$
34.  $\cos\left(\frac{5\pi}{12}\right) \cos\left(\frac{2\pi}{3}\right) + \sin\left(\frac{5\pi}{12}\right) \sin\left(\frac{2\pi}{3}\right)$
35.  $\frac{\tan 100^\circ + \tan 35^\circ}{1 - \tan 100^\circ \tan 35^\circ}$
36.  $\sin 125^\circ \cos 35^\circ - \cos 125^\circ \sin 35^\circ$
37.  $\frac{\tan\left(\frac{5\pi}{16}\right) - \tan\left(\frac{\pi}{16}\right)}{1 + \tan\left(\frac{5\pi}{16}\right) \tan\left(\frac{\pi}{16}\right)}$
38.  $\cos 15^\circ \cos 15^\circ - \sin 15^\circ \sin 15^\circ$
39.  $\sin 70^\circ \cos 80^\circ + \cos 70^\circ \sin 80^\circ$
40.  $\cos\left(\frac{\pi}{5}\right) \cos\left(\frac{3\pi}{10}\right) - \sin\left(\frac{\pi}{5}\right) \sin\left(\frac{3\pi}{10}\right)$
41.  $\cos 182^\circ \cos 47^\circ + \sin 182^\circ \sin 47^\circ$
42.  $\frac{\tan\left(\frac{5\pi}{12}\right) + \tan\left(\frac{3\pi}{4}\right)}{1 - \tan\left(\frac{5\pi}{12}\right) \tan\left(\frac{3\pi}{4}\right)}$
43.  $\frac{\tan 70^\circ - \tan 10^\circ}{1 + \tan 70^\circ \tan 10^\circ}$

$$44. \sin\left(\frac{5\pi}{12}\right)\cos\left(\frac{\pi}{12}\right) - \cos\left(\frac{5\pi}{12}\right)\sin\left(\frac{\pi}{12}\right)$$

Evaluate each of the following expressions. See Example 6.

$$45. \tan\left(\cos^{-1}\left(\frac{3}{5}\right) + \sin^{-1}\left(\frac{12}{13}\right)\right)$$

$$46. \cos\left(\arctan 1 + \arccos\left(\frac{1}{2}\right)\right)$$

$$47. \sin\left(\arctan \sqrt{3} + \arctan\left(\frac{4}{3}\right)\right)$$

$$48. \tan\left(\sin^{-1}\left(\frac{1}{\sqrt{2}}\right) - \cos^{-1}\left(\frac{5}{13}\right)\right)$$

Express each of the following as an algebraic function of  $x$ . See Example 7.

$$49. \sin(\sin^{-1}(2x) + \cos^{-1}(2x))$$

$$50. \sin(\arctan(2x) - \arccos(2x))$$

$$51. \cos(\arctan(2x) - \arcsin x)$$

$$52. \cos(\cos^{-1} x - \sin^{-1} x)$$

$$53. \cos(\arccos x + \arcsin(2x))$$

$$54. \sin(\sin^{-1} x - \cos^{-1} x)$$

Express each of the following functions in terms of a single sine function, and graph the result. See Example 9.

$$55. f(x) = \sin x + \cos x$$

$$56. g(x) = \sin x + \sqrt{3} \cos x$$

$$57. h(\beta) = \sin(2\beta) - \cos(2\beta)$$

$$58. f(\theta) = -\sqrt{3} \sin \theta + \cos \theta$$

$$59. g(u) = 5 \sin(5u) + 12 \cos(5u)$$

$$60. h(v) = 8 \cos\left(\frac{v}{2}\right) + 6 \sin\left(\frac{v}{2}\right)$$

### WRITING & THINKING

Use the sum and difference identities to verify the following identities. See Example 5.

$$61. \tan\left(\frac{\pi}{2} - \theta\right) = \cot \theta \quad (\text{Hint: Use sine and cosine.})$$

$$62. \cos^2 u - \sin^2 v = \cos(u+v)\cos(u-v)$$

$$63. \cos\left(\frac{3\pi}{2} - \alpha\right) = -\sin \alpha$$

$$64. \sin(\beta - \theta) + \sin(\beta + \theta) = 2 \sin \beta \cos \theta$$

$$65. \tan\left(\alpha - \frac{5\pi}{4}\right) = \frac{\tan \alpha - 1}{1 + \tan \alpha}$$

$$66. \sec\left(\frac{\pi}{2} - u\right) = \csc u$$

$$67. \tan(\pi + 2\pi) = 0$$

$$68. \sin\left(\frac{5\pi}{6} + \theta\right) = \frac{1}{2}(\cos \theta - \sqrt{3} \sin \theta)$$

$$69. \sin(u+v)\sin(u-v) = \sin^2 u - \sin^2 v \quad 70. \cos\left(\frac{7\pi}{4} - \beta\right) = \frac{\sqrt{2}}{2}(\cos \beta - \sin \beta)$$

71. Use a cofunction identity to prove the sum and difference identities for sine. (Hint: Note that  $\sin(u+v) = \cos\left(\frac{\pi}{2} - (u+v)\right) = \cos\left(\left(\frac{\pi}{2} - u\right) - v\right)$  and apply the difference identity for cosine.)

72. Given sum identities for sine and cosine, prove the sum identity for tangent.

73. Prove or disprove that  $\sin(u+v) + \sin(u-v) = 2\sin u \cos v$ .

74. Prove or disprove that  $\frac{\cos(u+v)}{\cos u \cos v} = \tan u + \tan v$ .

75. Prove or disprove that  $\frac{\cos(u-v)}{\cos(u+v)} = 2 \tan u \tan v$ .

76. Prove or disprove that  $\frac{\sin(u+v)}{\sin(u-v)} = \frac{\tan u + \tan v}{\tan u - \tan v}$ .

77. Use the sine and cosine difference formulas to prove  $\tan(u-v) = \frac{\tan u - \tan v}{1 + \tan u \tan v}$ .

### TECHNOLOGY

Using a graphing utility, determine whether the following identities are true or false.

(Hint: Graph both expressions on each side of the equality separately and determine if the graphs coincide.)

78.  $\sin\left(\frac{\pi}{2} - \theta\right) = \cos \theta$

79.  $\cos\left(\theta - \frac{3\pi}{2}\right) = -\sin \theta$

80.  $\cot(\pi + \theta) = -\tan \theta$

81.  $\sec\left(\frac{\pi}{2} - \theta\right) = \csc \theta$

82.  $\sin\left(\frac{\pi}{6} + \theta\right) = \frac{1}{2}(\cos \theta + \sqrt{3} \sin \theta)$

83.  $\frac{1 + \tan \theta}{1 - \tan \theta} = -\tan \theta$

## 8.3 EXERCISES

### PRACTICE

Use the given information to determine  $\cos(2x)$ ,  $\sin(2x)$ , and  $\tan(2x)$ , if possible. See Example 1.

1.  $\sin x = \frac{3}{5}$  and  $\cos x$  is positive
2.  $\tan x = -4$  and  $\sin x$  is negative
3.  $\cos x = -\frac{2}{\sqrt{6}}$  and  $\sin x$  is positive
4.  $\sin x = \frac{1}{\sqrt{5}}$  and  $\tan x$  is positive
5.  $\tan x = \frac{1}{\sqrt{3}}$  and  $\cos x$  is negative
6.  $\cos x = -3$  and  $\tan x$  is negative

Use a power-reducing identity to rewrite the given expression as directed. See Example 3.

7. Rewrite  $\sin^3 x$  in terms containing only first powers of sine and cosine.
8. Rewrite  $\sin^4 x$  in terms containing only first powers of cosine.
9. Rewrite  $\sin^4 x \cos^2 x$  in terms containing only first powers of cosine.
10. Rewrite  $\cos^3 x \sin^2 x$  in terms containing only first powers of cosine.
11. Rewrite  $\tan^4 x \sin x$  in terms containing only first powers of sine and cosine.
12. Rewrite  $\sin^8 x$  in terms containing only first powers of cosine.

Determine the exact value of each of the following expressions. See Examples 4 and 5.

13.  $\sin\left(\frac{3\pi}{8}\right)$
14.  $\tan(112^\circ 30')$
15.  $\cos\left(-\frac{\pi}{12}\right)$
16.  $\tan\left(\frac{7\pi}{12}\right)$
17.  $\sin 75^\circ$
18.  $\cos 165^\circ$

Use the product-to-sum identities to rewrite the given expression as a sum or difference. See Example 6.

19.  $\sin(3x)\cos(3x)$
20.  $\cos\left(\frac{\pi}{4}\right)\sin\left(\frac{\pi}{4}\right)$
21.  $5 \cos 105^\circ \sin 15^\circ$
22.  $2 \cos 75^\circ \cos 45^\circ$
23.  $\sin(x+y)\sin(x-y)$
24.  $\sin\left(\frac{5\pi}{6}\right)\cos\left(\frac{\pi}{6}\right)$
25.  $\sin\left(\frac{5\pi}{4}\right)\sin\left(\frac{2\pi}{3}\right)$
26.  $\cos \beta \cos(3\beta)$
27.  $2 \cos\left(\frac{\pi}{3}\right)\sin\left(\frac{\pi}{6}\right)$

Use the sum-to-product identities to rewrite the given expression as a product. See Example 7.

28.  $\sin\left(\frac{\pi}{4}\right) + \sin\left(\frac{3\pi}{4}\right)$

29.  $\sin(6x) + \sin(2x)$

30.  $\cos 60^\circ + \cos 30^\circ$

31.  $\cos(3\beta) - \cos \beta$

32.  $\sin \pi - \sin\left(\frac{\pi}{2}\right)$

33.  $\sin 135^\circ - \sin 15^\circ$

34.  $\cos(6x) - \cos(2x)$

35.  $\cos\left(\frac{7\pi}{6}\right) - \cos\left(\frac{\pi}{4}\right)$

36.  $\sin(\pi + \theta) + \sin(\pi - \theta)$

### WRITING & THINKING

Verify the following trigonometric identities. See Example 2.

37.  $\tan(3x) = \frac{3 \tan x - \tan^3 x}{1 - 3 \tan^2 x}$

38.  $\sin(2x) = \frac{2 \tan x}{1 + \tan^2 x}$

39.  $\frac{\sin(4x) - \sin(2x)}{\cos(4x) + \cos(2x)} = \tan x$

40.  $\frac{\sin(3x)}{\sin x} = 3 - 4 \sin^2 x$

41.  $2 \sin^2(3x) = 1 - \cos(6x)$

42.  $\sin(3x) = 3 \sin x \cos^2 x - \sin^3 x$

43. Two of the double-angle identities were proved in this section. Prove the remaining three double-angle identities.

44. The power-reducing identity for sine was proved in this section. Prove the remaining two power-reducing identities.

45. Prove the half-angle identities for sine and cosine by replacing  $x$  with  $\frac{x}{2}$  in an appropriately chosen identity.

46. One of the formulas in the tangent half-angle identity was proved in this section. Prove the second formula in the tangent half-angle identity.

47. As mentioned in this section,  $\cos(nx)$  can be expressed as a polynomial of degree  $n$  in  $\cos x$ ; such polynomials are called Chebyshev polynomials. For  $\sin(nx)$ , the equivalent rewriting is a product of  $\sin x$  and a polynomial of degree  $n - 1$  in  $\cos x$ . Expand  $\sin(nx)$  and  $\cos(nx)$  for  $n = 2, 3$ , and  $4$  and compare the results.

**Example 9: Solving Equations Using Inverse Trigonometric Functions**

Solve the equation  $6\sin x - 2 = \sin x$  on the interval  $[0, 2\pi)$ .

**Solution**

$$\begin{aligned} 6\sin x - 2 &= \sin x \\ 5\sin x &= 2 \\ \sin x &= 0.4 \end{aligned}$$

The trigonometric function can be easily isolated.

$$x = \sin^{-1}(0.4) \quad \text{or} \quad x = \pi - \sin^{-1}(0.4)$$

Note that since  $\sin x$  is positive,  $x$  lies in the first or second quadrant. The solution in the first quadrant is  $\sin^{-1}(0.4)$ , and the solution in the second quadrant has  $\sin^{-1}(0.4)$  as its reference angle.

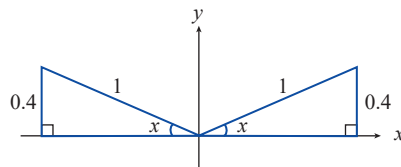

**FIGURE 5**

**8.4 EXERCISES****PRACTICE**

Use trigonometric identities and algebraic methods, as necessary, to solve the following trigonometric equations. See Examples 1 through 7.

- $2\sin x + 1 = 0$
- $4\sin^2 x + 2 = 3$
- $\sqrt{2} - 2\cos x = 0$
- $4\cos x = 2$
- $2\cos x - \sqrt{3} = 0$
- $\sin(2x) = \sqrt{3}\cos(2x)$
- $-\frac{1}{\sqrt{48}\sin x} = \frac{1}{8}$
- $\sin^2 x - \sin x = 2\sin x - 2$
- $\sqrt{3}\tan x + 1 = -2$
- $(3\tan^2 x - 1)(\tan^2 x - 3) = 0$
- $\sec^2 x - 1 = 0$
- $\sin^2 x = \sin^2 x + \cos^2 x$
- $\sec x + \tan x = 1$
- $\cos x + \sin x \tan x = 2$
- $\sin^2 x + \cos^2 x + \tan^2 x = 0$
- $\cos^2 x = 3\sin^2 x$
- $2\cos^2 x - 3 = 5\cos x$
- $\sin^3 x = \sin x$
- $\frac{\cot(2x)}{\sqrt{3}} = -1$
- $\cos x - 1 = \sin x$

Use trigonometric identities, algebraic methods, and inverse trigonometric functions, as necessary, to solve the following trigonometric equations on the interval  $[0, 2\pi)$ . See Examples 8 and 9.

21.  $2\sin^2 x + 7\sin x = 4$                       22.  $\tan^2 x = \tan x + 6$
23.  $2\cos^2 x - 1 = 0$                               24.  $\sec^2 x - 3 = -\tan x$
25.  $0.05\sin^3 x = 0.1\sin x$                       26.  $12\sin x - 1 = 8\sin x$
27.  $2\cos^2 x + 11\cos x = -5$                       28.  $10\sin x - 16 = -11 + 18\sin x$
29.  $\sec^2 x - 2 + 8\tan x = 42$                       30.  $\sin(-x) = 5\sin x - 3$

Verify that the  $x$ -values given are solutions to the given equation.

31.  $2\cos x + 1 = 0$                                   32.  $3\sec^2 x - 4 = 0$
- a.  $x = \frac{2\pi}{3}$     b.  $x = \frac{4\pi}{3}$                                   a.  $x = \frac{\pi}{6}$     b.  $x = \frac{5\pi}{6}$
33.  $2\sin^2 x - \sin x - 1 = 0$                       34.  $\tan^2(3x) = 3$
- a.  $x = \frac{\pi}{2}$     b.  $x = \frac{7\pi}{6}$                                   a.  $x = \frac{\pi}{9}$     b.  $x = \frac{2\pi}{9}$
35.  $\csc^4 x - 4\csc^2 x = 0$                           36.  $3\cot^2 x - 1 = 0$
- a.  $x = \frac{\pi}{6}$     b.  $x = \frac{5\pi}{6}$                                   a.  $x = \frac{\pi}{3}$     b.  $x = \frac{2\pi}{3}$
37.  $2\cot x + 1 = -1$                                 38.  $\csc^2 x = 2\cot x$
- a.  $x = \frac{3\pi}{4}$     b.  $x = \frac{7\pi}{4}$                                   a.  $x = \frac{\pi}{4}$     b.  $x = \frac{5\pi}{4}$
39.  $2\sec x + 1 = \sec x + 3$                       40.  $2\sin^2(2x) = 1$
- a.  $x = \frac{\pi}{3}$     b.  $x = \frac{5\pi}{3}$                                   a.  $x = \frac{\pi}{8}$     b.  $x = \frac{3\pi}{8}$

Determine if the value given is a solution to the trigonometric equation. If the value of  $x$  is not a solution, give all solutions to the equation.

41.  $2\cos x = -1$ ;  $x = \frac{4\pi}{3} + 2n\pi$                       42.  $\tan(3x)(\tan x - 1) = 0$ ;  $x = \frac{\pi}{4} + n\pi$
43.  $3\sec^2 x = 4$ ;  $x = \frac{\pi}{6} + n\pi$                       44.  $\sin^2 x - 3\cos^2 x = 0$ ;  $x = \frac{\pi}{3} + 2n\pi$
45.  $\sqrt{3}\csc x = 2$ ;  $x = \frac{2\pi}{3} + 2n\pi$                       46.  $2\sin^2 x - 1 = 0$ ;  $x = \frac{\pi}{4} + n\pi$
47.  $\tan x = -\sqrt{3}$ ;  $x = \frac{\pi}{6} + n\pi$                       48.  $\tan^2(3x) - 3 = 0$ ;  $x = \frac{2\pi}{9} + \frac{n\pi}{3}$
49.  $3\cot^2 x = 1$ ;  $x = \frac{\pi}{3} + n\pi$
50.  $\cos(2x)(2\cos x + 1) = 0$ ;  $x = \frac{5\pi}{6} + n\pi$

Use trigonometric identities and algebra, as necessary, to rewrite the following equations to be quadratic-like, and then solve each on the interval  $[0, 2\pi)$ .

51.  $2\sin^2 x - \sin x - 1 = 0$

52.  $2\sin^2 x + 3\cos x - 3 = 0$

53.  $\sin x - \cos x - 1 = 0$

54.  $\tan x + \sqrt{3} = \sec x$

55.  $\cos(2x) - \cos x = 0$

56.  $2\cos^2 x - \sqrt{3}\cos x = 0$

57.  $\csc^2 x - 2\cot x = 0$

Solve the following equations on the interval  $[0^\circ, 360^\circ)$ . Give the exact answers when appropriate; otherwise, round your answers to one decimal place.

58.  $\sin^2 x \cos x - \cos x = 0$

59.  $\cos^2 x = \sin^2 x$

60.  $\tan x = \cot x$

61.  $2\sin x = \csc x + 1$

62.  $\sec^2 x - 2\tan x = 4$

63.  $\sin^2 x = 2\sin x - 3$

64.  $2\cos^2 x - 1 = -2\cos x$

65.  $2\sin x \cot x + \sqrt{3}\cot x - 2\sqrt{3}\sin x - 3 = 0$

Solve the algebraic and trigonometric equations given. Restrict the solutions of the trigonometric equations to the interval  $[0, 2\pi)$ . Give the exact answers for  $s$ ; round your answers for  $t$  to four decimal places.

66.  $6s^2 - 13s + 6 = 0$ ;  $6\cos^2 t - 13\cos t + 6 = 0$

67.  $s^2 + s - 12 = 0$ ;  $\sin^2 t + \sin t - 12 = 0$

68.  $2s^2 + 7s - 15 = 0$ ;  $2\tan^2 t + 7\tan t - 15 = 0$

69.  $4s^2 - 4s - 1 = 0$ ;  $4\cos^2 t - 4\cos t - 1 = 0$

### APPLICATIONS

70. If an arrow is shot by an archer with an initial velocity  $v_0$  at an angle of  $\theta$  in reference to the horizontal, then its range, the horizontal distance it travels, is given by  $r = \frac{1}{32}v_0^2 \sin(2\theta)$ . If the initial velocity is  $v_0 = 100$  feet per second and the arrow hits a target 300 feet from where the archer is standing, what is the value, in degrees, of the angle  $\theta$ ? Round your answer to one decimal place.

71. A baseball leaves a bat at an angle of  $\theta$  in reference to the horizontal. The initial velocity is  $v_0 = 95$  feet per second. The ball is caught 160 feet from where it is hit. What is the value, in degrees, of the angle  $\theta$  if the range, the horizontal distance traveled by the ball, is given by  $r = \frac{1}{32}v_0^2 \sin(2\theta)$ ? Round your answer to one decimal place.

 TECHNOLOGY

Use a graphing utility to approximate the solutions of the given equation on the interval  $[0, 2\pi)$ . Round your answers to four decimal places.

72.  $x \tan x - 3 = 0$

73.  $2 \sin x + \cos x = 0$

74.  $2 \cos^2 x - \sin x = 0$

75.  $\cot^2 x - \sec^2 x = 0$

76.  $2 \sin x - \csc^2 x = 0$

77.  $2 \sin x = 1 - 2 \cos x$

78.  $\log x = -\sin x$

79.  $\sin\left(\frac{x}{2}\right) = 2 \cos(2x)$

Use a graphing utility to solve the following equations on the interval  $[0^\circ, 360^\circ)$ . Remember to change the mode to degrees.

80.  $2 \sin(2x) = \sqrt{3}$

81.  $\sin(3x) - \frac{1}{2} = 0$

82.  $2 \sin(4x) - 1 = 0$

 WRITING & THINKING

83. While working Exercises 66–69, what did you observe as the maximum number of real solutions the algebraic equations can have?
84. While working Exercises 66–69, what did you observe as the maximum number of real solutions the trigonometric equations can have on the interval  $[0, 2\pi)$ ?
85. While working Exercises 80–82, what did you observe about the solutions to the equations of the form  $y = \sin(ax)$  on the interval  $[0^\circ, 360^\circ)$ ?

## 9.1 EXERCISES

### PRACTICE

Solve for the remaining angle and sides of the triangles. See Examples 1 and 2.

1.  $A = 30^\circ, B = 45^\circ, a = 3$
2.  $A = 60^\circ, B = 40^\circ, a = 2$
3.  $A = 70^\circ, B = 50^\circ, b = 4$
4.  $A = 100^\circ, B = 20^\circ, b = 1$
5.  $B = 70^\circ, C = 30^\circ, c = 2$
6.  $B = 120^\circ, C = 40^\circ, b = 6$
7.  $A = 20^\circ, B = 10^\circ, a = 2$
8.  $B = 100^\circ, C = 30^\circ, a = 3$

Create a triangle, if possible, using the given information and the Law of Sines. See Examples 3 and 4.

9.  $A = 40^\circ, a = 2, b = 4$
10.  $A = 40^\circ, a = 4, b = 4$
11.  $C = 45^\circ, a = 2, c = 4$
12.  $A = 32^\circ, a = 4, b = 7$
13.  $C = 140^\circ, b = 1, c = 9$
14.  $A = 60^\circ, a = 5, c = 6$
15.  $B = 80^\circ, a = 2, b = 6$
16.  $B = 50^\circ, b = 2, c = 5$
17.  $B = 110^\circ, a = 1, b = 8$
18.  $A = 60^\circ, a = 10, b = 6$
19.  $C = 42^\circ, b = 9, c = 3$
20.  $B = 13.2^\circ, A = 63.7^\circ, b = 21.2$
21.  $A = 6^\circ 23', B = 64^\circ 15', c = 2.5$
22.  $C = 100^\circ, a = 18.1, c = 20.4$
23.  $A = 108^\circ, a = 9, b = 8.9$
24.  $C = 24^\circ, b = 2.4, c = 1.5$
25.  $B = 16.9^\circ, A = 29.7^\circ, b = 17.8$
26.  $A = 46^\circ 53', B = 74^\circ 13', c = 3.1$
27.  $C = 116^\circ, a = 24.1, c = 25$
28.  $A = 10^\circ, a = 2, b = 5$
29.  $A = 30^\circ, a = 15, b = 13$
30.  $C = 74^\circ, b = 4.5, c = 23$

Find the area of the triangle using the given information. See Example 5.

31.  $A = 131^\circ, b = 10, c = 25$
32.  $B = 60^\circ 7', c = 18, a = 6$
33.  $C = 103^\circ, a = 10, b = 2$
34.  $B = 54^\circ, a = 10, c = 7$
35.  $A = 67^\circ 49', c = 4.2, b = 9.5$
36.  $C = 46^\circ, b = 20, a = 19$
37.  $A = 86^\circ, b = 24, c = 28$

 APPLICATIONS

38. A plane flies 730 miles from Charleston, SC to Cleveland, OH with a bearing of N  $30^\circ$  W ( $30^\circ$  West of North). The plane then flies from Cleveland to Dallas, TX at a S  $42^\circ$  W bearing ( $42^\circ$  West of South). How far is Dallas from Charleston (assume Dallas and Charleston are at the same latitude)?

39. Jack wants to build a tree house. His parents worry that he is building it too high. If Jack's dad is looking at the tree house location from a  $70^\circ$  angle and then moves back 10 feet so he can see it at a  $50^\circ$  angle, how high is the tree house location?

40. A telephone pole was recently hit by a car and now leans  $6^\circ$  from the vertical. A point 40 feet away from the base of the pole has an angle of elevation of  $36^\circ$  to the top of the pole. How tall is the pole?

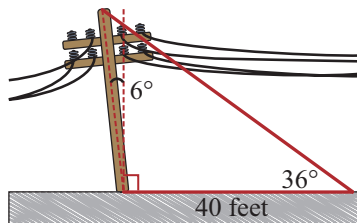

41. As Brandy prepares to land her plane on the runway, she is descending at a  $10^\circ$  angle from the horizontal. Behind her is a marker on the ground that is 500 feet from the runway, and at the marker the angle between the ground and Brandy's plane is  $50^\circ$ . What is the actual distance (not ground distance) between Brandy's plane and the runway?

42. A surveyor sets up two positions  $A$  and  $B$  500 yards apart as a baseline on a beach. From position  $A$ , he measures an angle of  $75^\circ$  between the baseline and a buoy offshore. From position  $B$  he measures an angle of  $50^\circ$  between the baseline and the buoy. How far is the buoy from each of the two positions?

43. Kristin is playing miniature golf. She hits the ball and it bounces off a brick, making a  $110^\circ$  angle. Her ball comes to a stop 8 feet away at a  $20^\circ$  angle from where it started. How far did the ball travel?

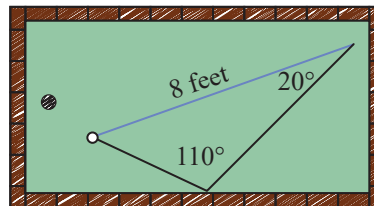

44. Janet is racing her friend Susan. Susan runs  $10^\circ$  away from Janet for 2000 feet. If she has to turn at a  $50^\circ$  angle to get back to Janet's path, how much shorter was Janet's run?

45. Two pieces of mail blew out into the yard. When Bob went to pick them up, he walked 10 feet to the first piece, turned  $40^\circ$  and walked to the next piece, and finally turned  $150^\circ$  to walk back to where he started. How far did Bob walk?

46. A horizontal bridge is suspended over a gorge, with the bridge and the sides of the gorge forming a downward-pointing isosceles triangle. If the bridge makes an  $80^\circ$  angle with the side of the gorge and the bridge is 1000 feet long, how deep is the gorge?

47. Brittany and Jim are playing catch. They are standing 30 feet away from each other. Ryan wants to join them and stands at a  $50^\circ$  angle away from Jim and at a  $70^\circ$  angle away from Brittany. How far away is Ryan from Jim and Ryan from Brittany?

48. Alan is golfing and sets up for a long drive. He slices it and hits a tree 80 feet away. The ball ricochets off of it at a  $110^\circ$  angle and comes to a stop  $20^\circ$  away from the direction he hit it. How far from Alan did the ball land?

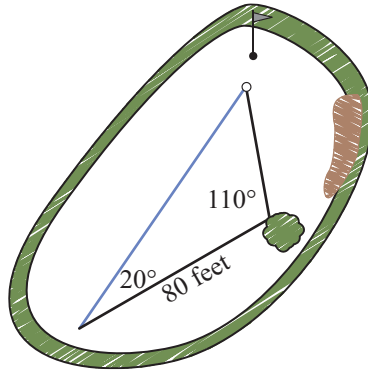

49. An airplane has to fly between 3 airports. The trip from the 1<sup>st</sup> to the 2<sup>nd</sup> is 120 miles. After landing at the 2<sup>nd</sup> airport, the airplane must turn  $140^\circ$  to head toward the 3<sup>rd</sup> airport. At the 3<sup>rd</sup> airport it must turn  $100^\circ$  to head to the first airport. How far does the airplane have to travel from the 2<sup>nd</sup> airport to the 3<sup>rd</sup>?
50. A ping pong net has become bent at a  $70^\circ$  angle instead of a  $90^\circ$  angle. The bottom of the net is 4.5 feet away from the end of the table. If the top of the net is 4.35 feet away from the end of the table, how high is the net?
51. A gymnast bends over backward until her hands touch the ground, at which point there is an angle of  $60^\circ$  between an imaginary line from her waist to her feet and an imaginary line from her waist to her hands. If the distance from her feet to her waist is 3 feet and the distance from her feet to her hands is 3.3 feet, what is the distance between her waist and hands?
52. Nancy wants to plant wildflowers between the two intersecting paths in her garden. If the paths intersect at a  $72^\circ$  angle and she wants the flowers to extend 12 feet down one path and 15 feet down the other, how large is the area she wants to plant?
53. An A-frame house overlooking the Atlantic Ocean has windows entirely covering one end. If the roof intersects at a  $54^\circ$  angle and the roof is 21 feet long from peak to ground, how much area do the windows cover?

## 9.2 EXERCISES

### PRACTICE

Solve for the remaining angles and side of the triangles. See Example 2.

- |                                 |                                  |
|---------------------------------|----------------------------------|
| 1. $A = 60^\circ, b = 3, c = 7$ | 2. $A = 40^\circ, b = 2, c = 3$  |
| 3. $B = 50^\circ, a = 4, c = 6$ | 4. $B = 45^\circ, a = 5, c = 4$  |
| 5. $C = 30^\circ, a = 8, b = 6$ | 6. $A = 110^\circ, b = 2, c = 1$ |
| 7. $C = 70^\circ, a = 5, b = 7$ | 8. $B = 100^\circ, a = 1, c = 3$ |

Solve for the angles of the given triangles. See Example 1.

- |                           |                           |
|---------------------------|---------------------------|
| 9. $a = 3, b = 4, c = 2$  | 10. $a = 5, b = 2, c = 6$ |
| 11. $a = 8, b = 6, c = 3$ | 12. $a = 9, b = 4, c = 7$ |
| 13. $a = 5, b = 5, c = 5$ | 14. $a = 6, b = 4, c = 7$ |
| 15. $a = 5, b = 3, c = 4$ | 16. $a = 7, b = 2, c = 8$ |

Create a triangle, if possible, using the given information and the Law of Cosines. See Examples 1 and 2.

- |  |   |
|--|---|
| 17. $A = 65^\circ, c = 13, b = 7$        | 18. $C = 35^\circ, b = 12, a = 14$        |
| 19. $B = 24.2^\circ, a = 13.3, c = 21.2$ | 20. $C = 46^\circ 7', a = 27.8, b = 19.4$ |
| 21. $A = 103^\circ, c = 8, b = 6.3$      | 22. $C = 75^\circ 4', b = 15.4, a = 16.8$ |
| 23. $b = 12, c = 9, a = 15$              | 24. $c = 4.78, b = 16.46, a = 16.54$      |
| 25. $b = 4.2, a = 7.6, c = 9.2$          | 26. $b = 6.84, c = 10.87, a = 7.37$       |
| 27. $a = 76.45, b = 94.45, c = 84.42$    | 28. $a = 5, b = 10, c = 7$                |

Find the area of the triangle using the given information. See Example 3.

- |                                 |                                  |
|---------------------------------|----------------------------------|
| 29. $b = 12, c = 18, a = 15$    | 30. $a = 3, b = 7, c = 8$        |
| 31. $a = 5.45, b = 4.83, c = 9$ | 32. $a = 4.2, b = 9.1, c = 11.5$ |

 APPLICATIONS

33. A log is seen floating down a stream. The log is first spotted 10 feet away. Ten seconds later the log is 70 feet away, making a  $60^\circ$  angle between the two sightings. How far did the log travel?

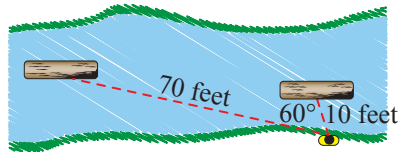

34. A bullet is fired and ricochets off a metal sign 100 feet away, making an  $80^\circ$  angle as it speeds toward a tree where it embeds itself. If the sign and tree are 60 feet apart, how far did the bullet stop from where it was fired?
35. Astronomers once thought the sun revolved around Earth. The sun is  $9.3 \times 10^7$  miles away and moves  $15^\circ$  across the sky in an hour. Assuming the sun travels in a straight line, how far would it have had to travel?

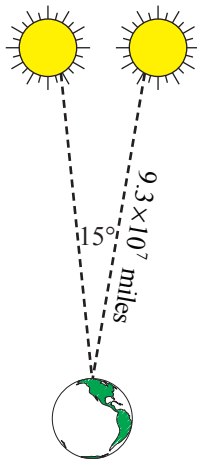

36. A pitcher 60 feet away throws a baseball to Joey. Joey bunts the ball at a  $20^\circ$  angle away from the pitcher. If the ball travels 50 feet, how far does the pitcher have to run to pick up the ball?

37. Nick is surfing a wave that carries him for 20 feet. He executes a sharp turn making a  $100^\circ$  angle. He rides the wave for 5 feet more before he topples into the water. How far is Nick from where he started?

38. A farmer puts a piece of fence across an inside corner of his barn to make a pen for his chickens. The lengths of the sides of the pen are 7 feet, 5 feet, and 8 feet. What are the respective angles?

39. Teresa wants to make a picture frame with two 5-inch and two 12-inch pieces of wood. If the diagonal length is 13 inches, what do the inside angles have to be for the two imaginary triangles?

40. Brian is up to bat. He hits the ball straight at the pitcher 60 feet away. The ball ricochets off the pitcher's shoulder at a  $100^\circ$  angle and comes to rest 40 feet away from the pitcher. How far did the ball travel away from Brian?

41. A plane took off and ascended for 1000 feet before leveling off. Once level, the plane flew for 500 feet, which put it 1480 feet directly away from where it started. After leveling off, what is the angle between the plane's current horizontal flight path and its ascending flight path?

42. Bob wants to build an ice skating rink in his backyard, but his wife says he can only use the part beyond the wood-chipped path running through their yard. How large would his rink be if it is triangular with sides of length 20 feet, 23 feet, and 32 feet?

43. The USS *Cyclops* mysteriously disappeared somewhere in the Bermuda Triangle in 1918. Miami, Florida; San Juan, Puerto Rico; and the Bermudas are generally accepted as the three points of the triangle. The distances from Miami to San Juan and from Miami to the Bermudas are both 908.2 nautical miles and the distance from San Juan to the Bermudas is 839.1 nautical miles. How large an area must be searched to look for the remains of the missing ship?

44. Brian just bought a used sailboat, but it needs a new triangular sail. The dimensions of the sail are 11 feet  $\times$  12 feet  $\times$  7 feet.
- What are the measures of the three angles of the sail?
  - How much fabric would a sail of this size require?
  - Suppose he plans to make the sail three different colors by dividing the largest angle so the 12-foot side is split into three sections of 5 feet (blue), 4 feet (yellow), and 3 feet (red), respectively. How much fabric of each color would he need?

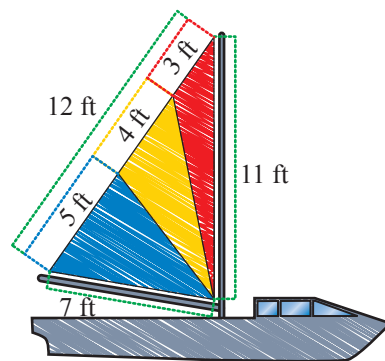

45. Any regular (all sides are equal)  $n$ -sided polygon can be divided into  $n$  identical triangles by drawing a line from each vertex to the center of the polygon. A pentagon would be divided as shown in the figure.

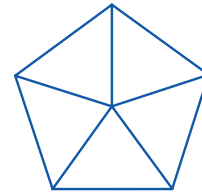

- If each side has a length of 6 inches, what would the area of the given pentagon be?
- Using a similar method, what would be the area of an octagon with sides of length 11 inches?
- What would be the area of a five-pointed star where each line segment has a length of 8 inches?

## 9.3 EXERCISES

### PRACTICE

Plot the point given by the polar coordinates. See Example 1.

- |  |                                      |   |
|--|--------------------------------------|---|
| 1. $\left(-1, \frac{5\pi}{4}\right)$       | 2. $\left(-5, \frac{3\pi}{2}\right)$ | 3. $\left(\frac{1}{4}, -\frac{7\pi}{6}\right)$      |
| 4. $\left(\sqrt{3}, -\frac{\pi}{3}\right)$ | 5. $\left(\frac{44}{9}, -\pi\right)$ | 6. $\left(\frac{7}{\sqrt{2}}, \frac{\pi}{2}\right)$ |

Convert the point from polar to Cartesian coordinates. See Example 2.

- |   |   |
|---|---|
| 7. $\left(5, \frac{7\pi}{4}\right)$     | 8. $(0, 2\pi)$                          |
| 9. $\left(6.25, -\frac{3\pi}{4}\right)$ | 10. $\left(-2.25, \frac{\pi}{4}\right)$ |
| 11. $\left(3, -\frac{5\pi}{6}\right)$   | 12. $\left(-11, \frac{5\pi}{6}\right)$  |

Convert the point from Cartesian to polar coordinates. See Example 3.

- |               |                      |                |
|---------------|----------------------|----------------|
| 13. $(-3, 0)$ | 14. $(-6, \sqrt{3})$ | 15. $(12, -1)$ |
| 16. $(8, 0)$  | 17. $(-\sqrt{3}, 9)$ | 18. $(-5, -5)$ |

Rewrite the rectangular equation in polar form. See Example 4.

- |                       |                      |                         |
|-----------------------|----------------------|-------------------------|
| 19. $x^2 + y^2 = 25$  | 20. $x^2 + y^2 = 81$ | 21. $x = 12$            |
| 22. $y = 16$          | 23. $y = x$          | 24. $y = b$             |
| 25. $x = 16a$         | 26. $x^2 + y^2 = a$  | 27. $x^2 + y^2 = 4ax$   |
| 28. $x^2 + y^2 = 4ay$ | 29. $y^2 - 4 = 4x$   | 30. $x^2 + y^2 = 36a^2$ |

Rewrite the polar equation in rectangular form. See Example 5.

- |  |  |                         |
|--|--|-------------------------|
| 31. $r = 5 \cos \theta$                            | 32. $r = 8 \sin \theta$                | 33. $r = 7$             |
| 34. $\theta = \frac{\pi}{6}$                       | 35. $18r = 9 \csc \theta$              | 36. $r = 2 \sec \theta$ |
| 37. $r^2 = \sin 2\theta$                           | 38. $r = \frac{2}{1 - \cos \theta}$    |                         |
| 39. $r = \frac{12}{4 \sin \theta + 7 \cos \theta}$ | 40. $r = \frac{16}{4 + 4 \sin \theta}$ |                         |



 TECHNOLOGY

Use a graphing utility to sketch each of the given curves. Whenever applicable, explore how different values of the parameter(s) affect the shape of the graph. Experiment with both integer and noninteger parameters.

75.  $r = \cos k\theta$

76.  $r = 1 - k_1 \sin k_2\theta$

77.  $r = \frac{1 + k \sin \theta}{1 - k \sin \theta}$

78.  $r = \theta \cos \theta, \quad -2\pi \leq \theta \leq 2\pi$   
(Garfield curve)

79.  $r = 1 + 2 \sin\left(\frac{\theta}{2}\right)$  (nephroid of Freeth)

80.  $r = k_1 + k_2\theta$

81.  $r = 1 - k_1 \cos k_2\theta$

## 9.4 EXERCISES

### 💡 PRACTICE

1. Given the parametric equations  $x = 5 + t$  and  $y = \frac{\sqrt{t}}{(t-2)}$ , construct a table of the points  $(x, y)$  that result from integer  $t$ -values from 0 to 6, and then sketch the curve.
2. Given the parametric equations  $x = \frac{\tan \theta}{2}$  and  $y = \cos^2 \theta + 3$ , construct a table of the points  $(x, y)$  that result from the values  $\theta = 0, \frac{\pi}{6}, \frac{\pi}{3}, \frac{\pi}{2}, \frac{2\pi}{3}, \frac{5\pi}{6}$ , and  $\pi$ . Using these points, sketch the graph of the equations.

Sketch the graphs of the following parametric equations by eliminating the parameter. See Examples 3 and 4.

- |   |  |
|---|--|
| 3. $x = 3(t+1)$ and $y = 2t$                          | 4. $x = \sqrt{t-2}$ and $y = 3t - 2$                       |
| 5. $x = 1 + t$ and $y = \frac{t-3}{2}$                | 6. $x =  t+3 $ and $y = t - 5$                             |
| 7. $x = \frac{t}{4}$ and $y = t^2$                    | 8. $x = \frac{t}{t+2}$ and $y = \sqrt{t}$                  |
| 9. $x = \sqrt{t+3}$ and $y = t + 3$                   | 10. $x = \frac{2}{ t-3 }$ and $y = 2t - 1$                 |
| 11. $x = \cos \theta$ and $y = 2\sin \theta$          | 12. $x = 3\sin \theta - 1$ and $y = \frac{\cos \theta}{2}$ |
| 13. $x = 1 - \sin \theta$ and $y = \sin \theta - 1$   | 14. $x = 2\cos \theta$ and $y = 3\cos \theta$              |
| 15. $x = 2\sin \theta + 2$ and $y = 2\cos \theta + 2$ | 16. $x = \sin \theta$ and $y = 4 - 3\cos \theta$           |

Construct parametric equations describing the graphs of the following equations. See Example 5.

- |                               |                     |                        |
|-------------------------------|---------------------|------------------------|
| 17. $y = (x+1)^2$             | 18. $y = 5x - 2$    | 19. $y = -x^2 - 5$     |
| 20. $x^2 + \frac{y^2}{4} = 1$ | 21. $x = y^2 + 4$   | 22. $y = x^2 + 1$      |
| 23. $y = \frac{1}{x}$         | 24. $x = 4y - 6$    | 25. $y =  x-1 $        |
| 26. $x = 2(y-3)$              | 27. $y^2 = 1 - x^2$ | 28. $x = \frac{1}{3y}$ |
| 29. $y = x^2 - x - 6$         |                     |                        |

Construct parametric equations for the line with the given attributes. (Answers will vary.)

- |   |  |
|---|--|
| 30. Slope $-2$ , passing through $(-5, -2)$ | 31. Slope $\frac{1}{4}$ , passing through $(10, 12)$ |
| 32. Slope $3$ , passing through $(7, 2)$    | 33. Passing through $(0, 0)$ and $(7, 4)$            |
| 34. Passing through $(6, -3)$ and $(2, 3)$  | 35. Passing through $(12, 3)$ and $(-4, -5)$         |

Using the given values for  $x$ , construct parametric equations describing the graph of each of the following equations.

36.  $y = 3x + 1$ , given that  $x = 2 + t$       37.  $y = 2 - |x|$ , given that  $x = t - 5$   
 38.  $y = 5 - x^2$ , given that  $x = t + 1$       39.  $5 = 2y + x$ , given that  $x = 4t$   
 40.  $\frac{x^2}{2} + 6 = y$ , given that  $x = t - 4$       41.  $(x - 2)^2 = y$ , given that  $x = 5t + 1$

Construct parametric equations for the circle with the given attributes. (Answers will vary.)

42. Center  $(0, 0)$ , radius 1      43. Center  $(-4, 2)$ , radius 3  
 44. Center  $(7, -5)$ , radius 4      45. Center  $(0, -2)$ , radius 6

### 🔗 APPLICATIONS

46. François shoots a basketball at an angle of  $48^\circ$  from the horizontal. It leaves his hands 7 ft from the ground with a velocity of 21 ft/s.
- Construct parametric equations representing the path of the ball.
  - Sketch a graph of the basketball's flight.
  - If the basket is 15 ft away and 11 ft high, will he make the shot?
47. Suppose that a circus performer is shot from a cannon at a rate of 80 mph, at an angle of  $60^\circ$  from the horizontal. The cannon sits on a platform 10 feet above the ground.

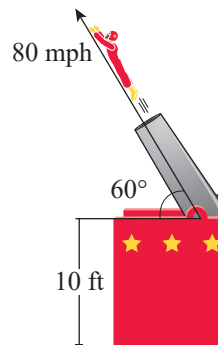

- Construct parametric equations representing the performer's path as he flies through the air.
- Sketch a graph of his flight.
- How high is the acrobat 1.5 seconds after leaving the cannon?
- How far from the cannon should a landing net be placed, if it is placed at ground level?
- At what time  $t$  will the performer land in the net?
- If a 12-foot-high wall of flames is placed 70 feet from the cannon, will he clear it unharmed?

48. On his morning paper route, John throws a newspaper from his car window 3.5 ft from the ground. The paper has an initial velocity of 10 ft/s and is tossed at an angle of  $10^\circ$  from the horizontal.
- Construct parametric equations modeling the path of the newspaper.
  - Sketch a graph of the paper's path.
49. A wheel of radius 12 inches rolls along a flat surface in a straight line. There is a fixed point  $P$  that initially lies at the point  $(0,0)$ . Find parametric equations defining the cycloid traced out by  $P$ .
50. A ball is rolled on the floor in a straight line from one person to another person. The ball has a radius of 3 cm and there is a fixed point  $P$  located on the ball. Let the person rolling the ball represent the origin. Find parametric equations defining the cycloid traced out by  $P$ .

## 9.5 EXERCISES

### 💡 PRACTICE

Graph and determine the magnitudes of the following complex numbers. See Example 1.

- |             |              |             |
|-------------|--------------|-------------|
| 1. $3 + 5i$ | 2. $-1 + 3i$ | 3. $2 - 4i$ |
| 4. $-6 - i$ | 5. $4 + 4i$  | 6. $5 + 2i$ |

Sketch  $z_1$ ,  $z_2$ ,  $z_1 + z_2$ , and  $z_1 z_2$  on the same complex plane.

- |                                  |                                   |
|----------------------------------|-----------------------------------|
| 7. $z_1 = 7 + 2i, z_2 = -2 + 3i$ | 8. $z_1 = -1 - 2i, z_2 = 4 + 4i$  |
| 9. $z_1 = 3 + i, z_2 = 5 - i$    | 10. $z_1 = 5 - 2i, z_2 = -1 + 5i$ |

Graph the regions of the complex plane defined by the following. See Example 2.

- |                                    |  |
|------------------------------------|--|
| 11. $\{z \mid  z  < 3\}$           | 12. $\{z \mid 1 \leq  z  \leq 4\}$     |
| 13. $\{z \mid  z  \geq 1\}$        | 14. $\{z = a + bi \mid a > 1, b > 2\}$ |
| 15. $\{z = a + bi \mid a \geq b\}$ | 16. $\{z \mid  z  = 4\}$               |

Write each of the following complex numbers in trigonometric form. See Example 3.

- |                            |                      |                     |
|----------------------------|----------------------|---------------------|
| 17. $-3 - i$               | 18. $5 - 3i$         | 19. $1 + 2i$        |
| 20. $3 + \sqrt{3}i$        | 21. $4 + 2i$         | 22. $5 - \sqrt{2}i$ |
| 23. $\sqrt{2} - \sqrt{2}i$ | 24. $2\sqrt{3} - 2i$ | 25. $3 + 4i$        |
| 26. $1 + i$                | 27. $4 - 4\sqrt{3}i$ | 28. $2\sqrt{2} - i$ |

Write each of the following complex numbers in standard form. See Example 4.

- |  |  |
|--|--|
| 29. $3\left(\cos\left(\frac{5\pi}{6}\right) + i\sin\left(\frac{5\pi}{6}\right)\right)$ | 30. $\cos\left(\frac{\pi}{3}\right) + i\sin\left(\frac{\pi}{3}\right)$   |
| 31. $2\left(\cos\left(\frac{4\pi}{3}\right) + i\sin\left(\frac{4\pi}{3}\right)\right)$ | 32. $6(\cos \pi + i \sin \pi)$   |
| 33. $5\left(\cos\left(\frac{3\pi}{4}\right) + i\sin\left(\frac{3\pi}{4}\right)\right)$ | 34. $\cos\left(\frac{5\pi}{4}\right) + i\sin\left(\frac{5\pi}{4}\right)$ |
| 35. $\frac{3}{2}(\cos 150^\circ + i \sin 150^\circ)$                                   | 36. $4(\cos 210^\circ + i \sin 210^\circ)$                               |
| 37. $5[\cos(78^\circ 20') + i \sin(78^\circ 20')]$                                     | 38. $3[\cos(121^\circ 40') + i \sin(121^\circ 40')]$                     |

Perform the following operations and show the answer in both trigonometric form and standard form. See Examples 5 and 6.

$$39. [4(\cos 60^\circ + i \sin 60^\circ)][4(\cos 330^\circ + i \sin 330^\circ)]$$

$$40. [3(\cos 180^\circ + i \sin 180^\circ)][4(\cos 30^\circ + i \sin 30^\circ)]$$

$$41. \left[ \sqrt{2} \left( \cos \left( \frac{5\pi}{4} \right) + i \sin \left( \frac{5\pi}{4} \right) \right) \right] \left[ 3\sqrt{3} \left( \cos \left( \frac{\pi}{6} \right) + i \sin \left( \frac{\pi}{6} \right) \right) \right]$$

$$42. \left[ 10 \left( \cos \left( \frac{5\pi}{6} \right) + i \sin \left( \frac{5\pi}{6} \right) \right) \right] \left[ 6 \left( \cos \left( \frac{2\pi}{3} \right) + i \sin \left( \frac{2\pi}{3} \right) \right) \right]$$

$$43. (-1 + 3i)(\sqrt{3} + i)$$

$$44. 2i(4 + 5i)$$

$$45. \frac{6(\cos 225^\circ + i \sin 225^\circ)}{3(\cos 45^\circ + i \sin 45^\circ)}$$

$$46. \frac{8(\cos 135^\circ + i \sin 135^\circ)}{4(\cos 30^\circ + i \sin 30^\circ)}$$

$$47. \frac{10 \left( \cos \left( \frac{5\pi}{3} \right) + i \sin \left( \frac{5\pi}{3} \right) \right)}{3 \left( \cos \left( \frac{7\pi}{6} \right) + i \sin \left( \frac{7\pi}{6} \right) \right)}$$

$$48. \frac{12 \left( \cos \left( \frac{10\pi}{3} \right) + i \sin \left( \frac{10\pi}{3} \right) \right)}{6(\cos(2\pi) + i \sin(2\pi))}$$

$$49. \frac{-i}{1+i}$$

$$50. \frac{-2-2i}{4+3i}$$

$$51. \frac{2e^{\frac{2\pi}{3}i}}{e^{\frac{\pi}{4}i}}$$

$$52. (e^{210^\circ i})(e^{90^\circ i})$$

Plot both complex numbers and, on the same graph, plot their product. See Example 7.

$$53. \left[ 4 \left( \cos \left( \frac{5\pi}{6} \right) + i \sin \left( \frac{5\pi}{6} \right) \right) \right] [2(\cos \pi + i \sin \pi)]$$

$$54. \left[ 5 \left( \cos \left( \frac{3\pi}{2} \right) + i \sin \left( \frac{3\pi}{2} \right) \right) \right] \left[ 3 \left( \cos \left( \frac{5\pi}{6} \right) + i \sin \left( \frac{5\pi}{6} \right) \right) \right]$$

$$55. (2 - 5i)(\sqrt{2} + 2i)$$

$$56. (-4 - 2i)(-\sqrt{3} + 4i)$$

$$57. \left( 2e^{\frac{\pi}{3}i} \right) \left( 3e^{\frac{5\pi}{4}i} \right)$$

$$58. \left( 5e^{\frac{5\pi}{3}i} \right) (e^{\pi i})$$

Use De Moivre's Theorem to calculate the following. See Example 8.

$$59. (1 - \sqrt{3}i)^5$$

$$60. \left( \frac{\sqrt{2}}{2} + \frac{\sqrt{2}}{2}i \right)^{22}$$

$$61. (5 + 3i)^{17}$$

$$62. (-\sqrt{3} + i)^{13}$$

$$63. \left( \cos \left( \frac{\pi}{4} \right) + i \sin \left( \frac{\pi}{4} \right) \right)^8$$

$$64. [2(\cos 135^\circ + i \sin 135^\circ)]^4$$

Find the indicated roots of the following and graphically represent each set in the complex plane. See Examples 9 and 10.

65. The fourth roots of  $-1$ .

66. The cube roots of  $64i$ .

67. The square roots of  $2\sqrt{3} + 2i$ .

68. The fourth roots of  $-1 - i$ .

69. The fourth roots of  $256$ .

70. The fourth roots of  $16\left(\cos\left(\frac{4\pi}{3}\right) + i\sin\left(\frac{4\pi}{3}\right)\right)$ .

71. The square roots of  $4(\cos 120^\circ + i\sin 120^\circ)$ .

Solve the following equations. See Examples 9 and 10.

72.  $z^3 - i = 0$

73.  $z^2 - 4\sqrt{3} - 4i = 0$

74.  $z^4 + 81i = 0$

75.  $z^5 + 32 = 0$

76.  $z^3 + 4\sqrt{2} - i = 0$

77.  $z^2 + 25i = 0$

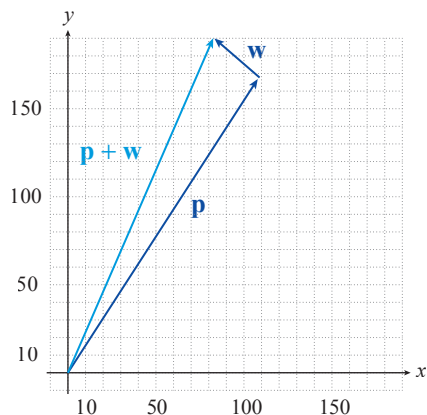

FIGURE 10

$$\mathbf{p} = 200\langle \cos 57^\circ, \sin 57^\circ \rangle \approx \langle 108.9, 167.7 \rangle$$

$$\mathbf{w} = 35\langle \cos 137^\circ, \sin 137^\circ \rangle \approx \langle -25.6, 23.9 \rangle$$

The plane's true velocity is now  $\mathbf{p} + \mathbf{w} = \langle 83.3, 191.6 \rangle$ . It may also be useful to determine that the speed of the plane is now  $\|\mathbf{p} + \mathbf{w}\| = \sqrt{(83.3)^2 + (191.6)^2} \approx 208.9$  miles per hour, and that its bearing is  $66.5^\circ$  North of East (which, using conventional bearing notation, would be written as N  $23.5^\circ$  E). This last angle is derived from the fact that  $\tan \theta = \frac{191.6}{83.3}$ , so  $\theta = \tan^{-1}\left(\frac{191.6}{83.3}\right) \approx 66.5^\circ$ . Figure 10 illustrates the three vectors in this problem.

### Example 7: Applying Vector Operations

A cat is slowly pushing a 5-pound plant across a table, with the intention of knocking it off the edge (determining why cats feel the need to do so is beyond the scope of this text). The cat is pushing with a force of 1 pound. What is the total force being applied to the plant?

#### Solution

Weight is itself a force—it is the force due to gravity that Earth exerts on an object. Forces exerted on an object are added as vectors, and the result is the total applied force. If we let  $\mathbf{F}_1$  denote the weight of the plant and  $\mathbf{F}_2$  the force exerted by the cat, the force  $\mathbf{F}$  on the plant is

$$\mathbf{F} = \mathbf{F}_1 + \mathbf{F}_2 = \langle 0, -5 \rangle + \langle 1, 0 \rangle = \langle 1, -5 \rangle.$$

The magnitude of  $\mathbf{F}$  is  $\sqrt{1+25} \approx 5.1$  pounds, and Figure 11 illustrates the situation.

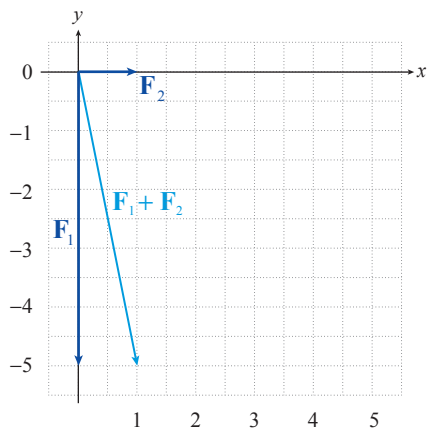
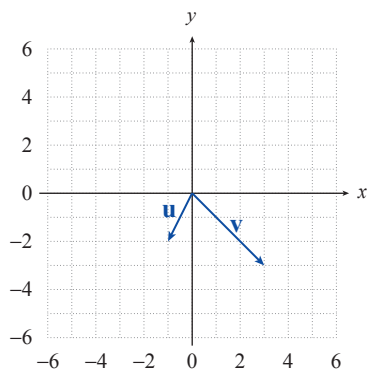

FIGURE 11

## 9.6 EXERCISES

### 💡 PRACTICE

Use the figure to sketch a graph for the specified vector. See Examples 1 and 2.



- |                                |  |
|--------------------------------|--|
| 1. $-\mathbf{u}$               | 2. $2\mathbf{u} + \mathbf{v}$            |
| 3. $3\mathbf{v}$               | 4. $-\frac{1}{2}\mathbf{u} - \mathbf{v}$ |
| 5. $2\mathbf{u} - 2\mathbf{v}$ | 6. $\mathbf{u} + 3\mathbf{v}$            |

Find the component form and the magnitude of vector  $\mathbf{v}$  for each of the following. See Example 3.

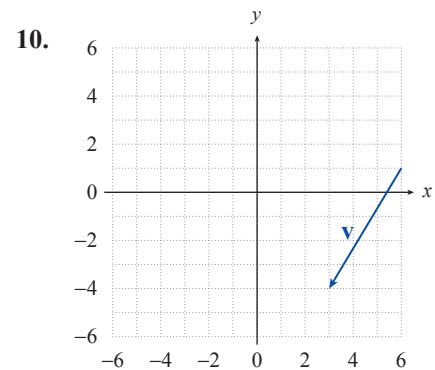
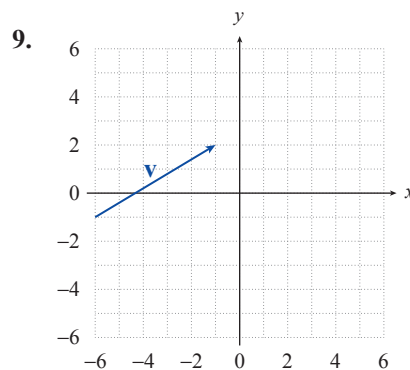
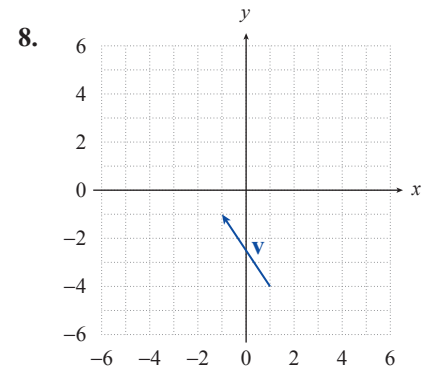
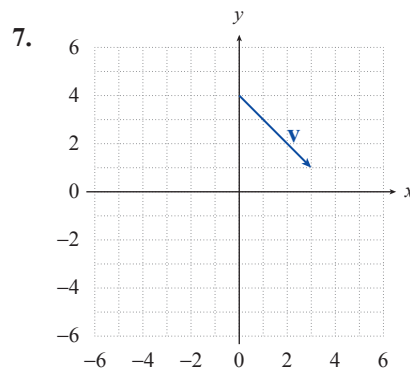

Find the component form and the magnitude of a vector  $\mathbf{v}$  defined by the given points. Assume the first point given is the initial point and the second point given is the terminal point. See Example 3.

11.  $(-2, 4), (3, 3)$

12.  $(1, 6), (2, 3)$

13.  $(5, -2), (-2, 5)$

14.  $(4, 0), (-1, 7)$

15.  $(3, 4), (-1, -2)$

16.  $(1, -6), (0, 0)$

For each of the following, calculate **a.**  $2\mathbf{u} + \mathbf{v}$ , **b.**  $-\mathbf{u} + 3\mathbf{v}$ , and **c.**  $-2\mathbf{v}$ . See Example 3.

17.  $\mathbf{u} = \langle -2, 4 \rangle, \mathbf{v} = \langle 2, 0 \rangle$

18.  $\mathbf{u} = \langle 4, 1 \rangle, \mathbf{v} = \langle 2, 5 \rangle$

19.  $\mathbf{u} = \langle 2, 0 \rangle, \mathbf{v} = \langle -3, 4 \rangle$

20.  $\mathbf{u} = \langle 1, 3 \rangle, \mathbf{v} = \langle 4, 4 \rangle$

21.  $\mathbf{u} = \langle -1, -4 \rangle, \mathbf{v} = \langle -3, -2 \rangle$

22.  $\mathbf{u} = \langle 0, -5 \rangle, \mathbf{v} = \langle -1, 2 \rangle$

For each of the following graphs, determine the component forms of  $-\mathbf{u}$ ,  $2\mathbf{u} - \mathbf{v}$ , and  $\mathbf{u} + \mathbf{v}$  and find the magnitudes of  $\mathbf{u}$  and  $\mathbf{v}$ . See Example 3.

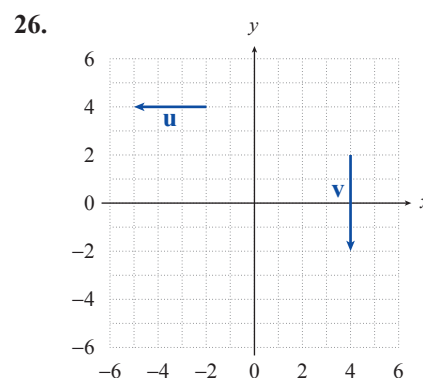
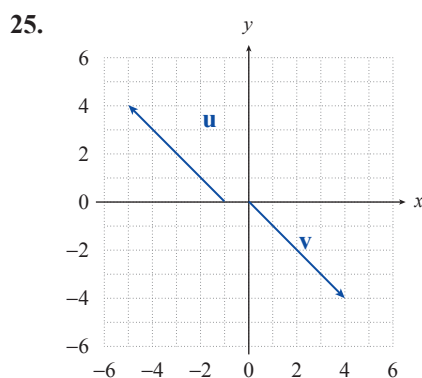
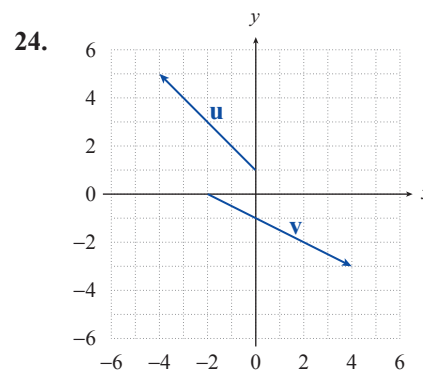
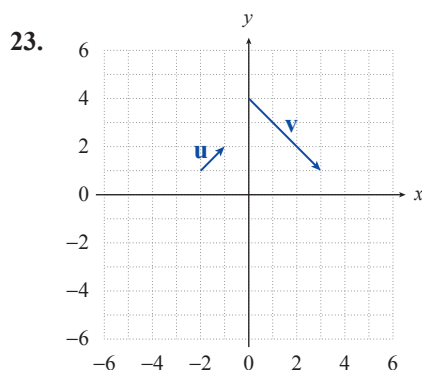

Given the vector  $\mathbf{u}$ , find **a.** a unit vector pointing in the same direction as  $\mathbf{u}$ , and **b.** the linear combination of  $\mathbf{i}$  and  $\mathbf{j}$  that is equivalent to  $\mathbf{u}$ . See Example 4.

27.  $\mathbf{u} = \langle 6, -3 \rangle$

28.  $\mathbf{u} = \langle 1, 4 \rangle$

29.  $\mathbf{u} = \langle -5, -1 \rangle$

30.  $\mathbf{u} = \langle -4, 3 \rangle$

31.  $\mathbf{u} = \langle 2, 3 \rangle$

32.  $\mathbf{u} = \langle 5, 2 \rangle$

Find the magnitude and direction angle of the vector  $\mathbf{v}$ .

33.  $\mathbf{v} = 5(\cos 30^\circ \mathbf{i} + \sin 30^\circ \mathbf{j})$

34.  $\mathbf{v} = 7(\cos 45^\circ \mathbf{i} + \sin 45^\circ \mathbf{j})$

35.  $\mathbf{v} = 4\mathbf{i} + 3\mathbf{j}$

36.  $\mathbf{v} = -2\mathbf{i} - 2\mathbf{j}$

Find the component form of  $\mathbf{v}$  given its magnitude and the angle it makes with the positive  $x$ -axis. See Example 5.

37.  $\|\mathbf{v}\| = 6, \theta = 30^\circ$

38.  $\|\mathbf{v}\| = \frac{5}{2}, \theta = 0^\circ$

39.  $\|\mathbf{v}\| = 18, \theta = 135^\circ$

40.  $\|\mathbf{v}\| = 3\sqrt{3}, \theta = 90^\circ$

41.  $\|\mathbf{v}\| = 1, \theta = 120^\circ$

42.  $\|\mathbf{v}\| = 4\sqrt{2}, \theta = 45^\circ$

43.  $\|\mathbf{v}\| = 4, \mathbf{v}$  in the direction of  $2\mathbf{i} + 3\mathbf{j}$

44.  $\|\mathbf{v}\| = 7, \mathbf{v}$  in the direction of  $\mathbf{i} + 4\mathbf{j}$

 APPLICATIONS

45. A paper airplane is launched into the air at a speed of 4 ft/s and at an angle of  $30^\circ$  from the horizontal. Express this velocity in vector form.
46. A golf ball is driven into the air at a speed of 75 miles per hour and at an angle of  $50^\circ$  from the horizontal. Express this velocity in vector form.
47. A sailboat is traveling at a speed of 45 miles per hour with a bearing of  $N 59^\circ W$ , when it encounters a front with winds blowing at 15 miles per hour with a bearing of  $S 3^\circ E$ . What is the resultant true velocity of the sailboat?
48. An underwater missile is traveling at a speed of 350 miles per hour and bearing of  $S 17^\circ W$ , when it meets a current traveling at 44 miles per hour in the direction of  $N 61^\circ W$ . What is the resultant true velocity of the underwater missile?
49. Prometheus is slowly pushing a 1235-pound boulder across a flat plain with a force of 150 pounds. What is the total force  $\mathbf{F}$  being applied to the boulder, and what is the magnitude of  $\mathbf{F}$ ?
50. A boy is pushing a toy truck across the floor. If the toy weighs 3 pounds and the boy is exerting half a pound of pressure on the toy, what is the total force  $\mathbf{F}$  being applied to the toy truck, and what is the magnitude of  $\mathbf{F}$ ?

motion is  $\|\mathbf{F}\|\cos\theta$ , where  $\theta$  is, as usual, the angle between the two vectors. The work done is then the product of  $\|\mathbf{D}\|$  and  $\|\mathbf{F}\|\cos\theta$ , that is,  $W = \|\mathbf{D}\|\|\mathbf{F}\|\cos\theta$ . But this last expression should look familiar—it appears in the Dot Product Theorem, allowing us to write the simpler formula below.

$$W = \mathbf{F} \cdot \mathbf{D}$$

### Example 7: Applying the Dot Product

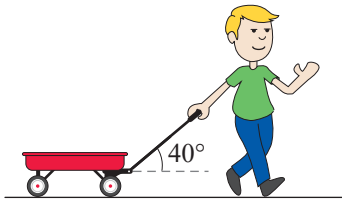

FIGURE 7

A child pulls a wagon along a sidewalk, exerting a force of 15 pounds on the handle of the wagon. The handle is at an angle of  $40^\circ$  to the horizontal. If the child pulls the wagon a distance of 50 feet, what work has been done?

#### Solution

We start by defining the force and distance vectors.

$$\mathbf{F} = 15\langle \cos 40^\circ, \sin 40^\circ \rangle \quad \text{and} \quad \mathbf{D} = \langle 50, 0 \rangle$$

The calculation is now straightforward.

$$\begin{aligned} W &= 15\langle \cos 40^\circ, \sin 40^\circ \rangle \cdot \langle 50, 0 \rangle \\ &\approx (15)(0.766)(50) + (15)(0.643)(0) \\ &= 574.5 \text{ foot-pounds} \end{aligned}$$

## 9.7 EXERCISES

### 💡 PRACTICE

Calculate each of the following dot products. See Example 1.

1.  $\langle 4, 3 \rangle \cdot \langle 5, -1 \rangle$
2.  $\langle 2, 4 \rangle \cdot \langle -1, -1 \rangle$
3.  $\langle 3, 5 \rangle \cdot \langle 2, 0 \rangle$
4.  $\langle -1, 6 \rangle \cdot \langle 6, 1 \rangle$
5.  $\langle 2, 2 \rangle \cdot \langle 2, 2 \rangle$
6.  $\langle 1, 2 \rangle \cdot \langle 3, 4 \rangle$
7.  $\langle -4, 3 \rangle \cdot \langle 2, 3 \rangle$
8.  $\langle -2, -4 \rangle \cdot \langle 6, 2 \rangle$
9.  $\mathbf{u} = 5\mathbf{i} + \mathbf{j}$ ,  $\mathbf{v} = -2\mathbf{i} + 3\mathbf{j}$
10.  $\mathbf{u} = \mathbf{i} - 5\mathbf{j}$ ,  $\mathbf{v} = -2\mathbf{i} - 4\mathbf{j}$

Find the indicated quantity given  $\mathbf{u} = \langle -2, 3 \rangle$  and  $\mathbf{v} = \langle 4, 4 \rangle$ . See Example 1.

11.  $\mathbf{v} \cdot \mathbf{v}$
12.  $4\mathbf{u} \cdot \mathbf{v}$
13.  $(\mathbf{u} \cdot \mathbf{u})\mathbf{u}$
14.  $(\mathbf{u} \cdot \mathbf{v})2\mathbf{v}$

Find the magnitude of  $\mathbf{u}$  using the dot product. See Example 2.

15.  $\mathbf{u} = \langle 6, -1 \rangle$
16.  $\mathbf{u} = \langle 10, 3 \rangle$
17.  $\mathbf{u} = 2\mathbf{i} + 7\mathbf{j}$
18.  $\mathbf{u} = -3\mathbf{i} + 4\mathbf{j}$

Find the angle between the given vectors. See Example 3.

19.  $\mathbf{u} = \langle -2, 3 \rangle$ ,  $\mathbf{v} = \langle 1, 0 \rangle$
20.  $\mathbf{u} = \langle 5, 4 \rangle$ ,  $\mathbf{v} = \langle 3, 2 \rangle$

21.  $\mathbf{u} = \langle 3, 5 \rangle, \mathbf{v} = \langle 4, 4 \rangle$

22.  $\mathbf{u} = \langle -4, 2 \rangle, \mathbf{v} = \langle 1, 5 \rangle$

23.  $\mathbf{u} = -\mathbf{i} + 2\mathbf{j}, \mathbf{v} = 3\mathbf{i} - 3\mathbf{j}$

24.  $\mathbf{u} = 5\mathbf{i} + 2\mathbf{j}, \mathbf{v} = 4\mathbf{i} + \mathbf{j}$

25.  $\mathbf{u} = \cos\left(\frac{3\pi}{4}\right)\mathbf{i} + \sin\left(\frac{3\pi}{4}\right)\mathbf{j}, \mathbf{v} = \cos\left(\frac{\pi}{2}\right)\mathbf{i} + \sin\left(\frac{\pi}{2}\right)\mathbf{j}$

26.  $\mathbf{u} = \cos\left(\frac{\pi}{4}\right)\mathbf{i} + \sin\left(\frac{\pi}{4}\right)\mathbf{j}, \mathbf{v} = \cos\left(\frac{5\pi}{6}\right)\mathbf{i} + \sin\left(\frac{5\pi}{6}\right)\mathbf{j}$

Use vectors to find the interior angles of the triangles given the following sets of vertices.

27.  $(3, 3), (4, 2), (-1, -6)$

28.  $(0, 0), (0, 5), (3, 6)$

29.  $(-2, -1), (2, 4), (-4, 5)$

30.  $(6, 3), (-5, 2), (-6, 1)$

Find  $\mathbf{u} \cdot \mathbf{v}$  where  $\theta$  is the angle between  $\mathbf{u}$  and  $\mathbf{v}$ . See Example 3.

31.  $\|\mathbf{u}\| = 25, \|\mathbf{v}\| = 5, \theta = 120^\circ$

32.  $\|\mathbf{u}\| = 4, \|\mathbf{v}\| = 64, \theta = \frac{\pi}{6}$

33.  $\|\mathbf{u}\| = 16, \|\mathbf{v}\| = 4, \theta = \frac{3\pi}{4}$

34.  $\|\mathbf{u}\| = 9, \|\mathbf{v}\| = 10, \theta = \frac{2\pi}{3}$

Find two vectors orthogonal to the given vector. See Example 4. Answers may vary.

35.  $\mathbf{u} = \langle 3, -3 \rangle$

36.  $\mathbf{u} = \langle 4, 1 \rangle$

37.  $\mathbf{u} = \langle 2, -6 \rangle$

38.  $\mathbf{u} = \langle 5, 4 \rangle$

Determine whether  $\mathbf{u}$  and  $\mathbf{v}$  are orthogonal, parallel, or neither. See Example 4.

39.  $\mathbf{u} = \langle 2, -3 \rangle, \mathbf{v} = \langle 1, 6 \rangle$

40.  $\mathbf{u} = \langle -12, 30 \rangle, \mathbf{v} = \left\langle \frac{1}{2}, -\frac{5}{4} \right\rangle$

41.  $\mathbf{u} = 2\mathbf{i} - 2\mathbf{j}, \mathbf{v} = -\mathbf{i} - \mathbf{j}$

42.  $\mathbf{u} = \mathbf{i}, \mathbf{v} = -2\mathbf{i} + 2\mathbf{j}$

Find the projection of  $\mathbf{u}$  onto  $\mathbf{v}$ , and then write  $\mathbf{u}$  as a sum of two orthogonal vectors, one of which is  $\text{proj}_{\mathbf{v}}\mathbf{u}$ . See Example 5.

43.  $\mathbf{u} = \langle 1, 3 \rangle, \mathbf{v} = \langle 4, 2 \rangle$

44.  $\mathbf{u} = \langle 2, 2 \rangle, \mathbf{v} = \langle 1, -7 \rangle$

45.  $\mathbf{u} = \langle 3, -5 \rangle, \mathbf{v} = \langle 6, 2 \rangle$

46.  $\mathbf{u} = \langle 0, 3 \rangle, \mathbf{v} = \langle 2, 6 \rangle$

47.  $\mathbf{u} = \langle -3, -3 \rangle, \mathbf{v} = \langle -4, -1 \rangle$

48.  $\mathbf{u} = \langle 4, 2 \rangle, \mathbf{v} = \langle 1, 5 \rangle$

Find the work done on a particle moving from  $J$  to  $K$  if the magnitude and direction of the force are given by  $\mathbf{F}$ . See Example 7.

49.  $J = (1, 4), K = (5, 6), \mathbf{F} = \langle 2, 3 \rangle$

50.  $J = (-3, 2), K = (0, 5), \mathbf{F} = \langle 4, 2 \rangle$

51.  $J = (3, 0), K = (-4, -2), \mathbf{F} = -\mathbf{i} + 2\mathbf{j}$

52.  $J = (3, -3), K = (5, 1), \mathbf{F} = 6\mathbf{i} - 3\mathbf{j}$

 APPLICATIONS

53. A truck with a gross weight of 25,000 pounds is parked on an  $8^\circ$  slope. What force is required to prevent the truck from rolling down the hill?
54. A child sits in his go-cart at the start position of a race atop a hill. If the hill has a slope of  $3^\circ$ , and the child and go-cart have a total weight of 250 pounds, what force is required to keep them stationary at the start position?
55. A woman on skis holds herself stationary, with the use of her ski poles, on a slope that is  $45^\circ$  from the horizontal. If the woman and her skis have a total weight of 155 pounds, what is the force required to prevent her from sliding down the slope?
56. A loaded furniture dolly is being pulled up a  $15^\circ$  ramp by a mover. When he pauses to rest, he has to exert 103.53 pounds of force just to keep the dolly stationary. How much does the loaded dolly weigh?
57. A child pulls a sled over the snow, exerting a force of 25 pounds on the attached rope. The rope is  $35^\circ$  from the horizontal. If the child pulls the sled a distance of 80 feet, what work has been done?
58. The world's strongest man pulls a log 200 feet, and the tension in the cable connecting the man and log is 3000 pounds. What is the work being done if the cable is being held  $15^\circ$  from the horizontal?
59. A recreational vehicle pulls a passenger car behind it, exerting 1250 pounds on the attachment point. The angle of attachment is  $30^\circ$  from the horizontal. If the RV pulls the car a distance of 2 miles, what work has been done?

## 9.8 EXERCISES

### 💡 PRACTICE

Evaluate each of the following expressions. Round your answers to two decimal places if necessary. See Example 1.

- |                   |                              |                            |
|-------------------|------------------------------|----------------------------|
| 1. $\sinh 0$      | 2. $\tanh 0$                 | 3. $\operatorname{sech} 0$ |
| 4. $\sinh(\ln 2)$ | 5. $\tanh(\ln 2)$            | 6. $\cosh(-2)$             |
| 7. $\coth(-2)$    | 8. $\operatorname{csch}(-2)$ | 9. $\cosh 5$               |

Use each of the given equations to classify the hyperbolic function as even or odd. Then use the definition of the function to prove your assertion.

- |   |  |
|---|--|
| 10. $\sinh(-x) = -\sinh x$                            | 11. $\cosh(-x) = \cosh x$                              |
| 12. $\tanh(-x) = -\tanh x$                            | 13. $\coth(-x) = -\coth x$                             |
| 14. $\operatorname{sech}(-x) = \operatorname{sech} x$ | 15. $\operatorname{csch}(-x) = -\operatorname{csch} x$ |

Verify each of the following identities. See Example 2.

16.  $e^{kx} = \cosh(kx) + \sinh(kx)$
17.  $e^{-kx} = \cosh(kx) - \sinh(kx)$
18.  $\sinh(x + y) = \sinh x \cosh y + \cosh x \sinh y$
19.  $\sinh(x - y) = \sinh x \cosh y - \cosh x \sinh y$
20.  $\cosh(x + y) = \cosh x \cosh y + \sinh x \sinh y$
21.  $\cosh(x - y) = \cosh x \cosh y - \sinh x \sinh y$
22.  $\sinh(2x) = 2 \sinh x \cosh x$
23.  $\cosh(2x) = \cosh^2 x + \sinh^2 x$
24.  $\cosh^2 x = \frac{\cosh(2x) + 1}{2}$
25.  $\coth^2 x = 1 + \operatorname{csch}^2 x$
26.  $\tanh(x + y) = \frac{\tanh x + \tanh y}{1 + \tanh x \tanh y}$
27.  $\tanh(x - y) = \frac{\tanh x - \tanh y}{1 - \tanh x \tanh y}$
28.  $\tanh(2x) = \frac{2 \tanh x}{1 + \tanh^2 x}$

$$29. \coth(2x) = \frac{1 + \coth^2 x}{2 \coth x} \qquad 30. \sinh\left(\frac{x}{2}\right) = \pm \sqrt{\frac{\cosh x - 1}{2}}$$

$$31. \cosh\left(\frac{x}{2}\right) = \sqrt{\frac{\cosh x + 1}{2}} \qquad 32. \tanh\left(\frac{x}{2}\right) = \pm \sqrt{\frac{\cosh x - 1}{\cosh x + 1}}$$

$$33. (\cosh x + \sinh x)^2 = \cosh(2x) + \sinh(2x)$$

$$34. (\cosh x + \sinh x)^n = \cosh(nx) + \sinh(nx), \quad n \in \mathbb{N}$$

$$35. (\cosh x - \sinh x)^n = \cosh(nx) - \sinh(nx), \quad n \in \mathbb{N}$$

Evaluate each of the following expressions. See Example 3.

$$36. \cosh^{-1} 1$$

$$37. \tanh^{-1} 0$$

$$38. \operatorname{sech}^{-1} 1$$

### WRITING & THINKING

Given that the hyperbolic functions can be expressed in terms of exponential functions, it's not surprising that their inverses can be expressed in terms of logarithms. For example, if we let  $y = \sinh^{-1} x$ , then  $x = \sinh y$  and we have the following.

$$x = \frac{e^y - e^{-y}}{2}$$

$$2x = e^y - e^{-y}$$

$$e^y - 2x - e^{-y} = 0$$

$$e^{2y} - 2xe^y - 1 = 0$$

$$(e^y)^2 - 2xe^y - 1 = 0$$

$$e^y = \frac{2x \pm \sqrt{4x^2 + 4}}{2}$$

$$e^y = x + \sqrt{x^2 + 1}$$

$$y = \ln(x + \sqrt{x^2 + 1})$$

Multiply through by  $e^y$ .

Express as a quadratic in  $e^y$ .

Solve for  $e^y$ .

$x - \sqrt{x^2 + 1} < 0$  but  $e^y > 0$ ,  
so discard  $x - \sqrt{x^2 + 1}$ .

Take the natural logarithm  
of both sides.

Use this procedure to verify each of the following identities.

$$39. \cosh^{-1} x = \ln(x + \sqrt{x^2 - 1}), \quad x \geq 1$$

$$40. \tanh^{-1} x = \frac{1}{2} \ln\left(\frac{1+x}{1-x}\right), \quad -1 < x < 1$$

**(Hint:** Begin by setting  $y = \tanh^{-1} x$ ; then write the equation as  $\tanh y = x$ , square both sides, and apply the identity  $\tanh^2 y = 1 - \operatorname{sech}^2 y$ . Solve the result for  $\cosh y$ , apply  $\cosh^{-1}$  to both sides, and apply the result of the previous exercise. Then apply some logarithmic properties.)

Given a function  $f$ , let  $\frac{1}{f}$  denote its reciprocal—that is,  $\left(\frac{1}{f}\right)(x) = \frac{1}{f(x)}$ . The following is a useful relationship between the functions  $f^{-1}$  and  $\left(\frac{1}{f}\right)^{-1}$ , assuming both of these inverse functions exist.

$$\begin{aligned}\left(\frac{1}{f}\right)\left(f^{-1}\left(\frac{1}{x}\right)\right) &= \frac{1}{f\left(f^{-1}\left(\frac{1}{x}\right)\right)} = \frac{1}{\frac{1}{x}} = x \\ \text{so } \left(\frac{1}{f}\right)^{-1}(x) &= f^{-1}\left(\frac{1}{x}\right).\end{aligned}$$

Applied to hyperbolic functions, this fact indicates the following.

$$\operatorname{csch}^{-1} x = \sinh^{-1} \frac{1}{x}, \quad \operatorname{sech}^{-1} x = \cosh^{-1} \frac{1}{x}, \quad \operatorname{coth}^{-1} x = \tanh^{-1} \frac{1}{x}$$

Use these relationships to verify each of the following identities.

$$41. \operatorname{csch}^{-1} x = \ln \left( \frac{1}{x} + \frac{\sqrt{1+x^2}}{|x|} \right), \quad x \neq 0$$

$$42. \operatorname{sech}^{-1} x = \ln \left( \frac{1 + \sqrt{1-x^2}}{x} \right), \quad 0 < x \leq 1$$

$$43. \operatorname{coth}^{-1} x = \frac{1}{2} \ln \left( \frac{x+1}{x-1} \right), \quad |x| > 1$$

Evaluate each of the following expressions using the formulas from Exercises 39–43. Round your answers to two decimal places.

$$44. \sinh^{-1} 2$$

$$45. \operatorname{csch}^{-1}(-3)$$

$$46. \cosh^{-1} 5$$

$$47. \operatorname{sech}^{-1}(0.8)$$

$$48. \tanh^{-1}(-0.3)$$

$$49. \operatorname{coth}^{-1} 3$$

Substituting back into our first equation, we have  $c \approx 94.56 - 92.98$ , so  $c \approx 1.58$ .

The closest approach to the sun must be a distance of  $a - c$ , which is approximately  $92.98 - 1.58 = 91.40$  million miles.

## 10.1 EXERCISES

### 💡 PRACTICE

Find the center, foci, and vertices of the ellipse that each equation describes. See Examples 1, 2 and 3.

- $\frac{(x-5)^2}{4} + \frac{(y-2)^2}{25} = 1$
- $\frac{(x+3)^2}{9} + \frac{(y+1)^2}{16} = 1$
- $(x+2)^2 + 3(y+5)^2 = 9$
- $4(x-4)^2 + (y-2)^2 = 8$
- $x^2 + 6x + 2y^2 - 8y + 13 = 0$
- $2x^2 + y^2 - 4x + 4y - 10 = 0$
- $4x^2 + y^2 + 40x - 2y + 85 = 0$
- $x^2 + 2y^2 - 6x + 16y + 37 = 0$
- $x^2 + 3y^2 + 8x - 12y + 1 = 0$
- $4x^2 + 3y^2 - 8x + 18y + 19 = 0$
- $x^2 - 4x + 5y^2 - 1 = 0$
- $x^2 + 4y^2 + 24y + 28 = 0$

Match the following equations to their graphs.

13.  $\frac{(x-1)^2}{4} + \frac{y^2}{81} = 1$

14.  $\frac{(x-3)^2}{49} + \frac{(y-2)^2}{25} = 1$

15.  $\frac{(x+4)^2}{9} + \frac{(y-3)^2}{4} = 1$

16.  $\frac{(x+3)^2}{36} + \frac{(y-1)^2}{64} = 1$

17.  $\frac{(x+3)^2}{4} + \frac{(y+3)^2}{9} = 1$

18.  $\frac{x^2}{16} + \frac{(y+5)^2}{4} = 1$

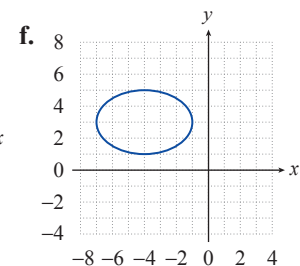
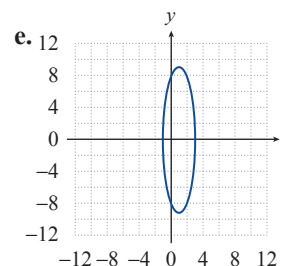
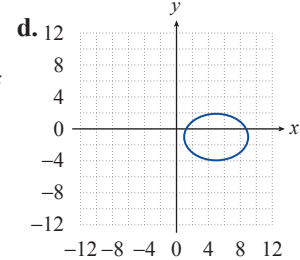
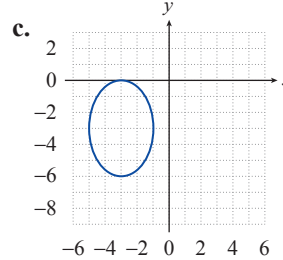
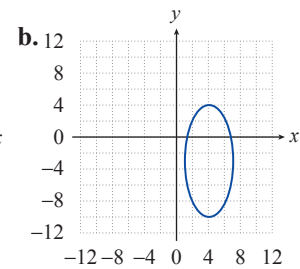
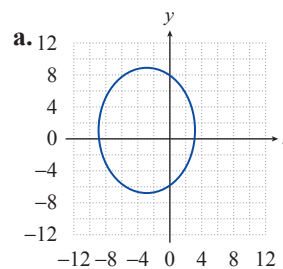

$$19. \frac{(x-4)^2}{9} + \frac{(y+3)^2}{49} = 1$$

$$20. \frac{(x-5)^2}{16} + \frac{(y+1)^2}{9} = 1$$

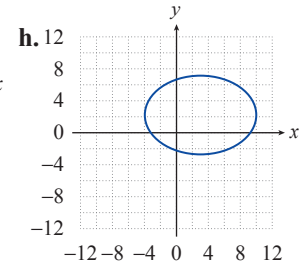
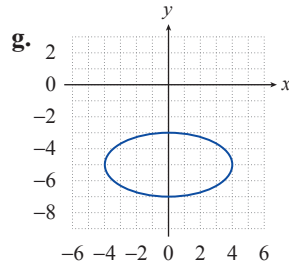

Sketch the graphs of the following ellipses and determine the coordinates of the foci. See Examples 1, 2, and 3.

$$21. \frac{(x-3)^2}{9} + \frac{(y+1)^2}{1} = 1$$

$$22. \frac{(x+5)^2}{4} + \frac{(y+2)^2}{16} = 1$$

$$23. \frac{(x-3)^2}{9} + \frac{(y-4)^2}{4} = 1$$

$$24. \frac{x^2}{25} + \frac{(y-3)^2}{16} = 1$$

$$25. (x-1)^2 + \frac{(y-4)^2}{4} = 1$$

$$26. \frac{(x-4)^2}{16} + \frac{(y-4)^2}{4} = 1$$

$$27. \frac{(x+1)^2}{25} + \frac{(y+5)^2}{4} = 1$$

$$28. \frac{(x-2)^2}{9} + \frac{(y+1)^2}{9} = 1$$

$$29. \frac{(x+2)^2}{16} + \frac{(y+1)^2}{9} = 1$$

$$30. \frac{x^2}{25} + (y+2)^2 = 1$$

$$31. 9x^2 + 16y^2 + 18x - 64y = 71$$

$$32. 9x^2 + 4y^2 - 36x - 24y + 36 = 0$$

$$33. 16x^2 + y^2 + 160x - 6y = -393$$

$$34. 25x^2 + 4y^2 - 100x + 8y + 4 = 0$$

$$35. 4x^2 + 9y^2 + 40x + 90y + 289 = 0$$

$$36. 16x^2 + y^2 - 64x + 6y + 57 = 0$$

$$37. 4x^2 + y^2 + 4y = 0$$

$$38. 9x^2 + 4y^2 + 108x - 32y = -352$$

In each of the following exercises, an ellipse is described by either a picture or by the properties it possesses. Find the equation, in standard form, for each ellipse. See Example 4.

39. Center at the origin, major axis of length 10 on the  $y$ -axis, foci 3 units from the center.

40. Center at  $(-2, 3)$ , major axis of length 8 oriented horizontally, minor axis of length 4.

41. Vertices at  $(1, 4)$  and  $(1, -2)$ , foci  $2\sqrt{2}$  units from the center.

42. Vertices at  $(5, -1)$  and  $(1, -1)$ , minor axis of length 2.

43. Foci at  $(0, 0)$  and  $(6, 0)$ ,  $e = \frac{1}{2}$ .

44. Vertices at  $(-1, 4)$  and  $(-1, 0)$ ,  $e = 0$ .

45. Vertices at  $(-2, -1)$  and  $(-2, -5)$ , minor axis of length 2.

46. Vertices at  $(-4, 6)$  and  $(-14, 6)$ ,  $e = \frac{2}{5}$ .
47. Vertices at  $(1, 3)$  and  $(9, 3)$ , one of the foci at  $(6, 3)$ .
48. Foci at  $(2, -4)$  and  $(2, -8)$ , minor axis of length 6.

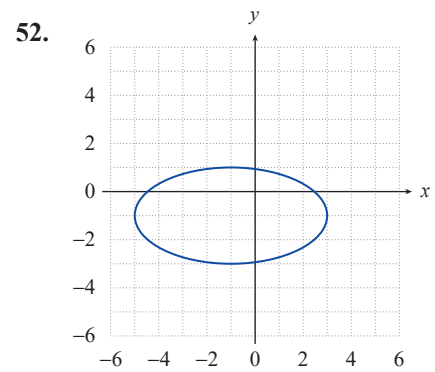
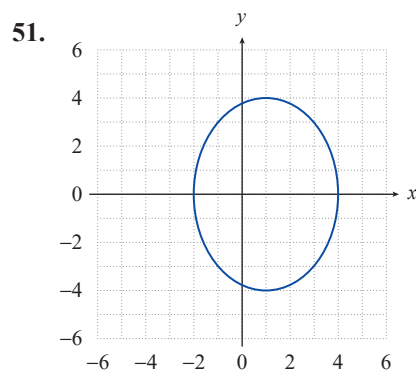
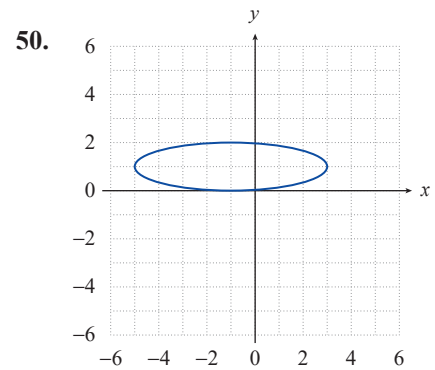
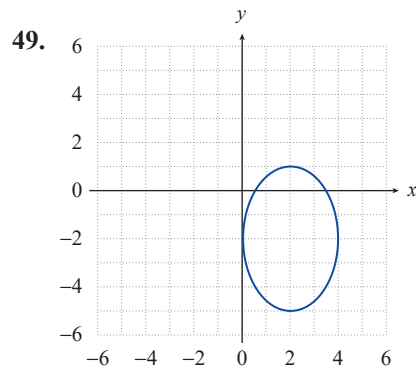

Find the eccentricity and the lengths of the minor and major axes of the following ellipses.

53.  $\frac{x^2}{100} + \frac{y^2}{144} = 1$       54.  $\frac{x^2}{64} + \frac{y^2}{9} = 1$       55.  $x^2 + 9y^2 = 36$
56.  $25x^2 + 4y^2 = 100$       57.  $4x^2 + 16y^2 = 16$       58.  $5x^2 + 8y^2 = 40$
59.  $20x^2 + 10y^2 = 40$       60.  $\frac{1}{4}x^2 + \frac{1}{12}y^2 = \frac{1}{2}$       61.  $x^2 = 49 - 7y^2$

APPLICATIONS

62. The orbit of Halley's Comet is an ellipse with an eccentricity of 0.967. Its closest approach to the sun is approximately 54,591,000 miles. What is the farthest Halley's Comet ever gets from the sun?

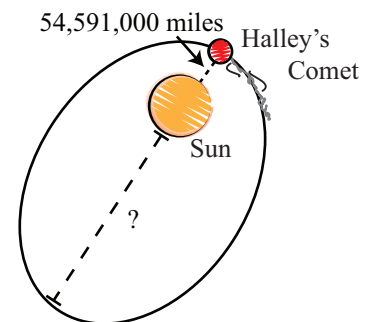

63. Pluto's closest approach to the sun is approximately  $4.43 \times 10^9$  kilometers, and its maximum distance from the sun is approximately  $7.37 \times 10^9$  kilometers. What is the eccentricity of Pluto's orbit?
64. Use the information given in Example 5 to determine the length of the minor axis of the ellipse formed by Earth's orbit around the sun.
65. The archway supporting a bridge over a river is in the shape of half an ellipse. The archway is 60 feet wide and is 15 feet tall at the middle. A boat is 10 feet wide and 14 feet, 9 inches tall. Is the boat capable of passing under the archway?

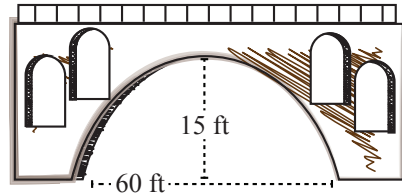

66. *The Whispering Gallery* in Chicago's Museum of Science and Industry is a giant ellipsoid that transmits the slightest whisper from one focus to the other focus. This giant ellipse is known to have a length of about 568 inches and a width of about 162 inches. Find the eccentricity of *The Whispering Gallery*. About how far apart are two whisperers when communicating in this gallery? Round your answers to four decimal places.

### ✎ WRITING & THINKING

67. Since the sum of the distances from each of the two foci to any point on an ellipse is constant, we can draw an ellipse using the following method. Tack the ends of a length of string at two points (the foci) and, keeping the string taut by pulling outward with the tip of a pencil, trace around the foci to form an ellipse (the total length of the string remains constant). If you want to create an ellipse with a major axis of length 5 cm and a minor axis of length 3 cm, how long should your string be and how far apart should you place the tacks? Use the relationships of distances and formulas that you have learned in this section.

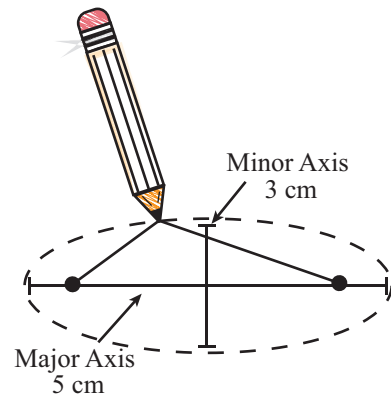

68. Using the method described in Exercise 67, describe the change in your ellipse when you move the two foci closer together. What happens when you move them farther apart?

### 📊 TECHNOLOGY

Use a graphing utility to graph the following equations.

69.  $15x^2 + 9y^2 + 150x - 36y = -276$       70.  $5x^2 + 12y^2 - 20x + 144y + 392 = 0$
71.  $3x^2 + 2y^2 = 3 - 18x$       72.  $2x^2 + 5y^2 = 70y - 205$

**NOTE**

The same concept can be used to focus sunlight, intensely heating a small area at the focus. This is called a parabolic furnace.

**Solution**

First, we need to draw a picture of the situation. In order to make the math as easy as possible, we can locate the origin of our coordinate system at the vertex of a parabolic cross section of the mirror, and we can assume the parabola opens upward.

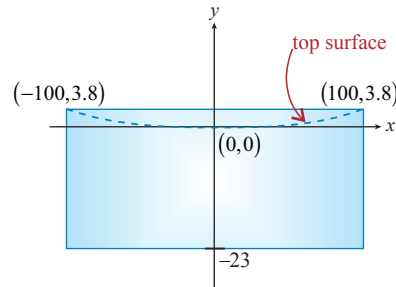
**FIGURE 9**

Since we placed the vertex at  $(0,0)$ , we know the equation  $x^2 = 4py$  describes the shape of the cross section for some value  $p$ . If we can determine  $p$ , we can find the focus of the parabola.

To find  $p$ , we need the coordinates of another point on the parabola. The difference in thickness of the mirror between the center and the outer rim is 3.8 inches, and the mirror has a diameter of 200 inches, so the two points  $(-100, 3.8)$  and  $(100, 3.8)$  must lie on the graph. Plugging a point into the equation  $x^2 = 4py$ , we can solve for  $p$ .

$$\begin{aligned}(100)^2 &= 4p(3.8) \\ 10000 &= 15.2p \\ p &\approx 657.9 \text{ inches} \\ p &\approx 54.8 \text{ feet}\end{aligned}$$

We know that the focus of a parabola is  $p$  units from the vertex, so the focus of the Hale Telescope is nearly 55 feet from the mirror.

**10.2 EXERCISES****PRACTICE**

Graph the following parabolas and determine the focus and directrix of each. See Examples 1 and 2.

1.  $(x+1)^2 = 4(y-3)$

2.  $y^2 - 4y = 8x + 4$

3.  $(y-4)^2 = -2(x-1)$

4.  $(y-1)^2 = 8(x+3)$

5.  $(x-2)^2 = 4(y+1)$

6.  $(y+1)^2 = -12(x+1)$

7.  $y^2 = 6x$

8.  $x^2 = 2y$

9.  $x^2 = 7y$

10.  $x^2 = -5y$

11.  $y = -12x^2$

12.  $x = -4y^2$

13.  $x = \frac{1}{6}y^2$

14.  $\frac{1}{5}x = -y^2$

15.  $y^2 + 16x = 0$

16.  $-6x - 2y^2 = 0$

17.  $4y + 2x^2 = 4$

18.  $2y^2 - 10x = 10$

19.  $y^2 + 2y + 12x + 37 = 0$

20.  $x^2 - 8y = 6x - 1$

21.  $x^2 + 6x + 8y = -17$

22.  $x^2 + 2x + 8y = 31$

23.  $y^2 + 6y - 2x + 13 = 0$

24.  $y^2 - 2y - 4x + 13 = 0$

Match the following equations to their graphs.

25.  $(x+2)^2 = 3(y-1)$

26.  $(y-1)^2 = 2(x+2)$

27.  $y^2 = 4(x+1)$

28.  $x^2 = 2(y+1)$

29.  $(x-1)^2 = -(y-2)$

30.  $(y+2)^2 = 3x$

31.  $(x-2)^2 = 4y$

32.  $y^2 = -2(x+1)$

a.

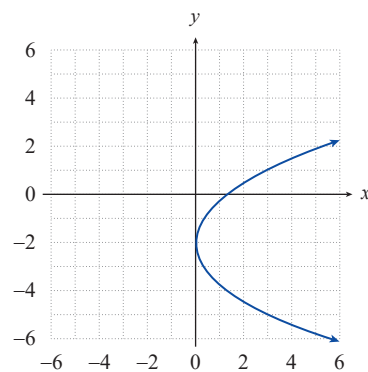

b.

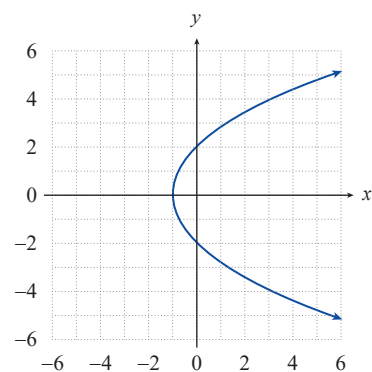

c.

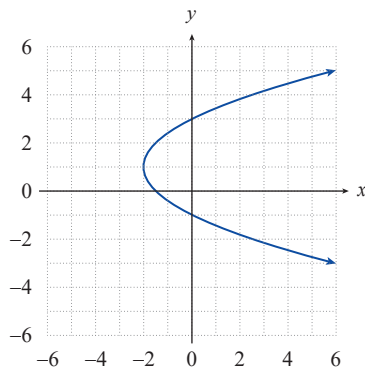

d.

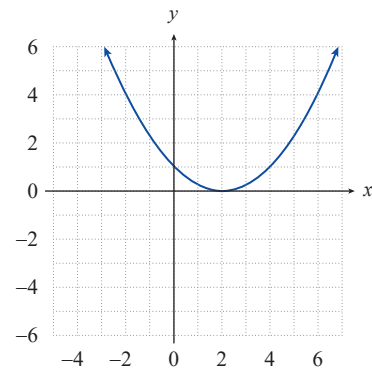

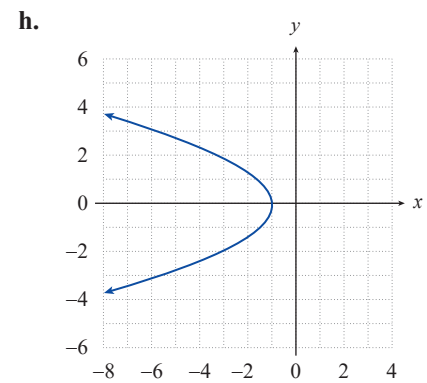
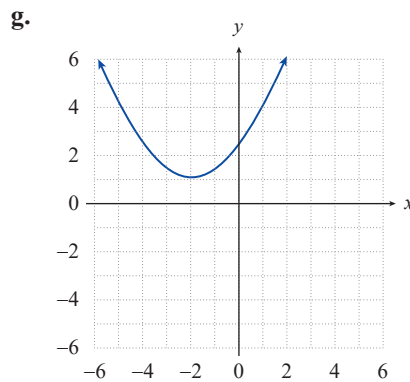
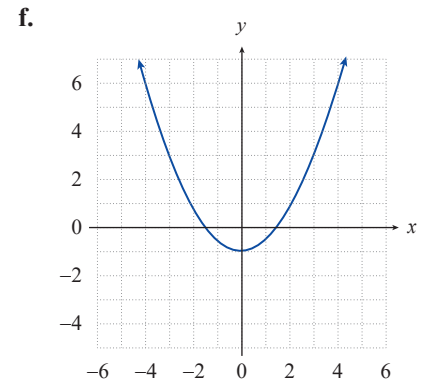
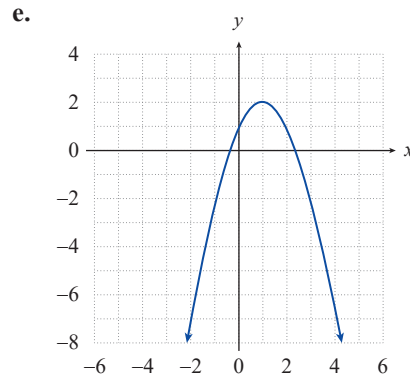

Find the equation, in standard form, for the parabola with the given properties or with the given graph. See Example 3.

33. Focus at  $(-2, 1)$ , directrix is the  $y$ -axis.
34. Focus at  $(-2, 1)$ , directrix is the  $x$ -axis.
35. Vertex at  $(3, -1)$ , focus at  $(3, 1)$ .
36. Symmetric with respect to the line  $y = 1$ , directrix is the line  $x = 2$ , and  $p = -3$ .
37. Vertex at  $(3, -2)$ , directrix is the line  $x = -3$ .
38. Vertex at  $(7, 8)$ , directrix is the line  $x = \frac{27}{4}$ .
39. Focus at  $\left(-3, -\frac{3}{2}\right)$ , directrix is the line  $y = -\frac{1}{2}$ .
40. Vertex at  $(3, 16)$ , focus at  $(3, 11)$ .
41. Vertex at  $(-4, 3)$ , focus at  $\left(-\frac{3}{2}, 3\right)$ .
42. Symmetric with respect to the  $x$ -axis, focus at  $(-3, 0)$ , and  $p = 2$ .

43.

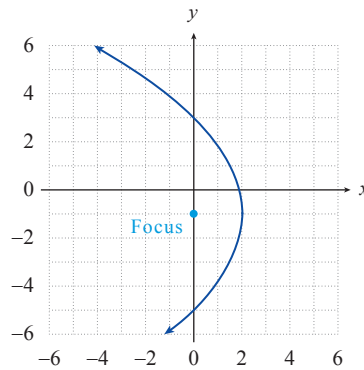

44.

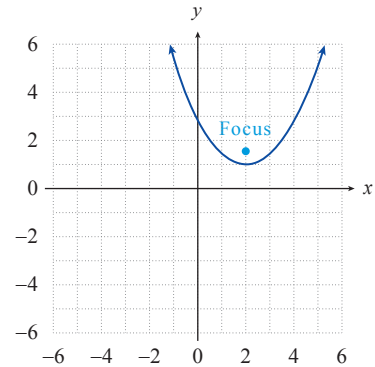

### APPLICATIONS

45. One design for a solar furnace is based on the paraboloid formed by rotating the parabola  $x^2 = 8y$  around its axis of symmetry. The object to be heated in the furnace is then placed at the focus of the paraboloid (assume that  $x$  and  $y$  are in units of feet). How far from the vertex of the paraboloid is the hottest part of the furnace?
46. A certain brand of satellite dish antenna is a paraboloid with a diameter of 6 feet and a depth of 1 foot. How far from the vertex of the dish should the receiver of the antenna be placed given that the receiver should be located at the focus of the paraboloid?
47. A spotlight is made by placing a strong lightbulb inside a reflective paraboloid formed by rotating the parabola  $x^2 = 6y$  around its axis of symmetry (assume that  $x$  and  $y$  are in units of inches). In order to have the brightest, most concentrated light beam, how far from the vertex should the bulb be placed?

### TECHNOLOGY

Use a graphing utility to graph the following equations.

48.  $3x^2 - 4y + 24x = -56$

49.  $y^2 + 2y = 8x - 41$

50.  $y^2 - 6y + 4x = -17$

51.  $x^2 - 6x + 12y + 21 = 0$

LORAN can actually determine the location of the ship by performing the same computations for another pair of simultaneous signals sent out from two additional transmitters, located at  $A'$  and  $B'$ . This defines a second hyperbola, and the ship must be at a point where the two hyperbolas intersect, as shown in Figure 10.

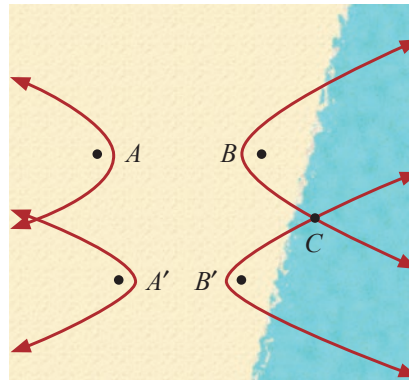

FIGURE 10: Two Sets of Transmitters

## 10.3 EXERCISES

### 💡 PRACTICE

Sketch the graphs of the following hyperbolas, using asymptotes as guides. Determine the coordinates of the foci in each case. See Examples 1 and 2.

1.  $\frac{(x+3)^2}{4} - \frac{(y+1)^2}{9} = 1$

2.  $\frac{(y-2)^2}{25} - \frac{(x+2)^2}{9} = 1$

3.  $4y^2 - x^2 - 24y + 2x = -19$

4.  $x^2 - 9y^2 + 4x + 18y - 14 = 0$

5.  $9x^2 - 25y^2 = 18x - 50y + 241$

6.  $9x^2 - 16y^2 + 116 = 36x + 64y$

7.  $\frac{x^2}{16} - \frac{(y-2)^2}{4} = 1$

8.  $\frac{(y-1)^2}{9} - (x+3)^2 = 1$

9.  $9y^2 - 25x^2 - 36y - 100x = 289$

10.  $9x^2 + 18x = 4y^2 + 27$

11.  $9x^2 - 16y^2 - 36x + 32y - 124 = 0$

12.  $x^2 - y^2 + 6x - 6y = 4$

13.  $\frac{(y-2)^2}{64} - \frac{(x+7)^2}{49} = 1$

14.  $\frac{(y-4)^2}{49} - \frac{(x+2)^2}{16} = 1$

15.  $\frac{(x+1)^2}{64} - \frac{(y+7)^2}{4} = 1$

16.  $\frac{(x+10)^2}{16} - \frac{(y+8)^2}{25} = 1$

Find the center, foci, and vertices of the hyperbola that each equation describes.

17.  $\frac{(x+3)^2}{4} - \frac{(y-2)^2}{9} = 1$

18.  $\frac{(y-2)^2}{16} - \frac{(x+1)^2}{9} = 1$

19.  $3(x-1)^2 - (y+4)^2 = 9$

20.  $(y-2)^2 - 2(x-4)^2 = 4$

21.  $(x+2)^2 - 5(y-1)^2 = 25$

22.  $6(y+2)^2 - (x+1)^2 = 12$

23.  $2x^2 + 12x - y^2 - 2y + 9 = 0$

24.  $y^2 - 9x^2 + 6y + 72x - 144 = 0$

25.  $x^2 - 4y^2 - 2x = 0$

26.  $4y^2 - x^2 + 32y + 2x + 47 = 0$

27.  $4x^2 - y^2 - 64x + 10y + 167 = 0$

28.  $4x^2 - 9y^2 - 36y - 72 = 0$

Match the following equations to their graphs.

29.  $\frac{x^2}{9} - y^2 = 1$

30.  $y^2 - \frac{x^2}{4} = 1$

31.  $x^2 - \frac{(y-3)^2}{4} = 1$

32.  $\frac{(x-3)^2}{4} - \frac{(y+1)^2}{9} = 1$

33.  $(y+2)^2 - \frac{(x-2)^2}{4} = 1$

34.  $\frac{x^2}{9} - \frac{(y+2)^2}{4} = 1$

35.  $\frac{y^2}{4} - (x-1)^2 = 1$

36.  $x^2 - y^2 = 1$

a.

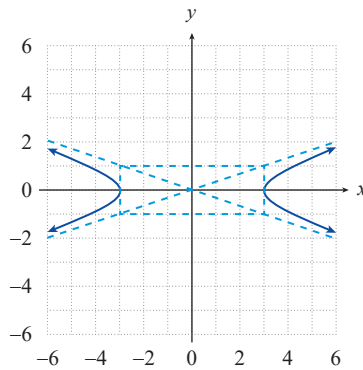

b.

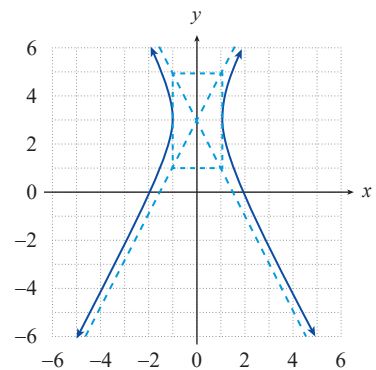

c.

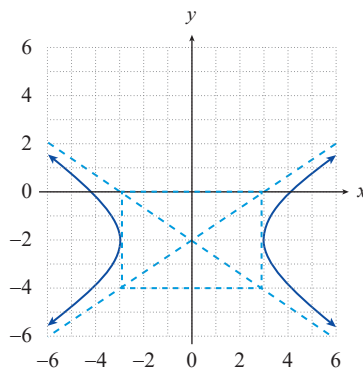

d.

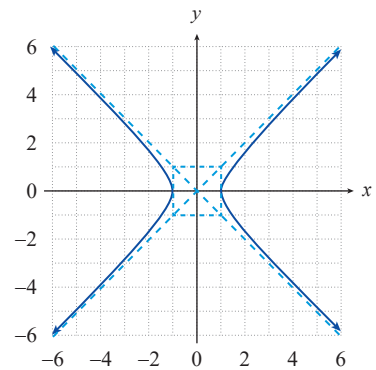

e.

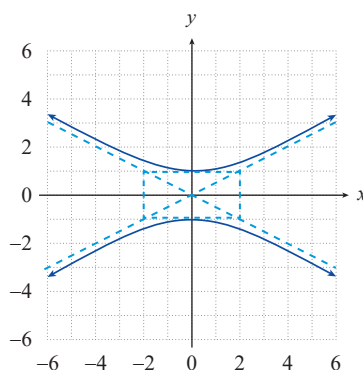

f.

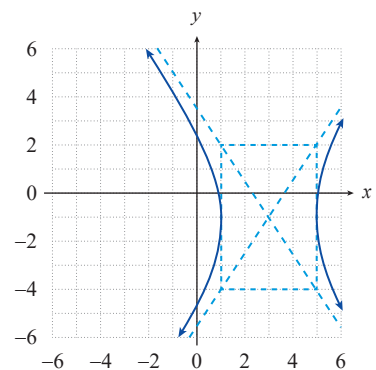

g.

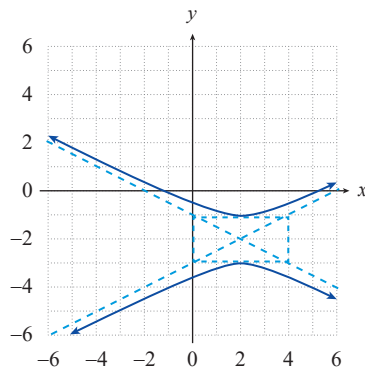

h.

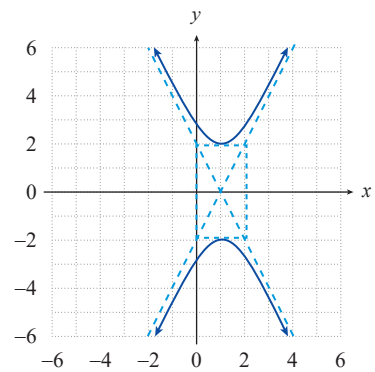

Find the equation, in standard form, for the hyperbola with the given properties or with the given graph. See Example 3.

37. Foci at  $(-3, 0)$  and  $(3, 0)$  and vertices at  $(-2, 0)$  and  $(2, 0)$ .
38. Foci at  $(1, 5)$  and  $(1, -1)$  and vertices at  $(1, 3)$  and  $(1, 1)$ .
39. Asymptotes of  $y = \pm 2x$  and vertices at  $(0, -1)$  and  $(0, 1)$ .
40. Asymptotes of  $y = \pm(x - 2) + 1$  and vertices at  $(-1, 1)$  and  $(5, 1)$ .
41. Foci at  $(2, 4)$  and  $(-2, 4)$  and asymptotes of  $y = \pm 3x + 4$ .
42. Foci at  $(-1, 3)$  and  $(-1, -1)$  and asymptotes of  $y = \pm(x + 1) + 1$ .
43. Foci at  $(2, 5)$  and  $(10, 5)$  and vertices at  $(3, 5)$  and  $(9, 5)$ .
44. Foci at  $(7, 4)$  and  $(7, -4)$  and vertices at  $(7, 1)$  and  $(7, -1)$ .
45. Asymptotes of  $y = \pm(2x + 8) + 3$  and vertices at  $(-6, 3)$  and  $(-2, 3)$ .
46. Asymptotes of  $y = \pm \frac{4}{3}x - 3$  and vertices at  $(0, -7)$  and  $(0, 1)$ .

47.

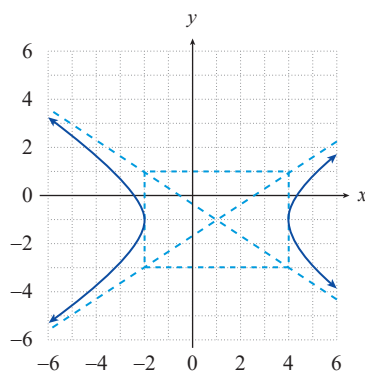

48.

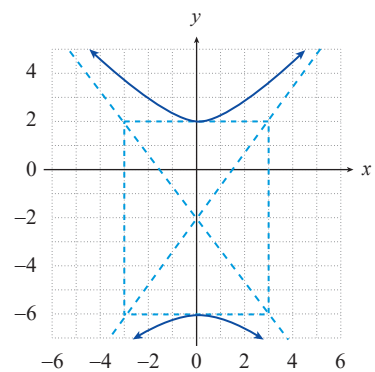

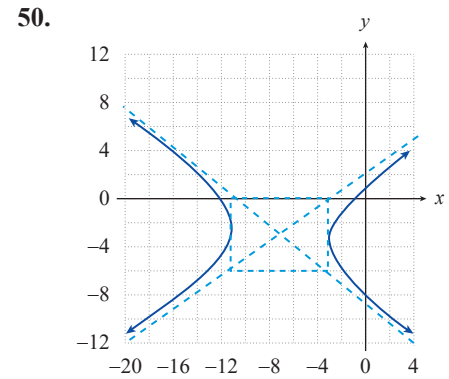
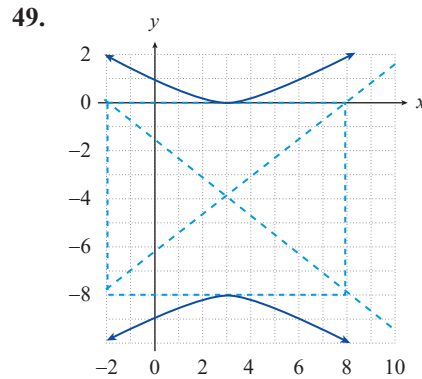

### 🔗 APPLICATIONS

51. As mentioned in this section, some comets trace one branch of a hyperbola through the solar system, with the sun at one focus. Suppose a comet is spotted that appears to be headed straight for Earth, as shown in the figure. As the comet gets closer, however, it becomes apparent that it will pass between Earth, which lies at the center of the hyperbolic path of the comet, and the sun. In the end, the closest the comet comes to Earth is 60,000,000 miles. Using an estimate of 94,000,000 miles for the distance from Earth to the sun, and positioning Earth at the origin of a coordinate system, find the equation for the path of the comet.

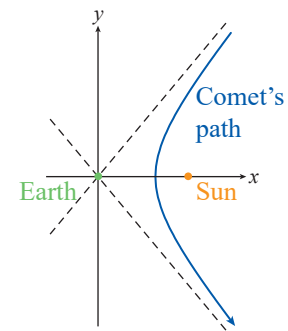

52. Suppose two LORAN radio transmitters are 26 miles apart. A ship at sea receives signals sent simultaneously from the two transmitters and is able to determine that the difference between the distances from the ship to each of the transmitters is 24 miles. By positioning the two transmitters on the  $y$ -axis, each 13 miles from the origin, find the equation for the hyperbola that describes the set of possible locations for the ship.

### 📊 TECHNOLOGY

Use a graphing utility to graph the following equations.

- |                                   |                                  |
|-----------------------------------|----------------------------------|
| 53. $x^2 - 6y^2 = 15$             | 54. $4y^2 - 9x^2 = 18$           |
| 55. $3y^2 - 18x^2 = 36$           | 56. $x^2 - 6 = 3y^2$             |
| 57. $(y+2)^2 - 20 = 5x^2$         | 58. $(x+5)^2 = 3(y-2)^2 + 15$    |
| 59. $x^2 - 2y^2 = 4x + 12y + 26$  | 60. $2x^2 - y^2 + 12x + 2y = 3$  |
| 61. $5x^2 - y^2 + 20x = 10y + 25$ | 62. $x^2 - 5y^2 = 14x + 20y - 4$ |

## 10.4 EXERCISES

### PRACTICE

Find the  $x'y'$ -coordinates of each point for the given rotation angle  $\theta$ . See Example 1.

1.  $(8, 6), \theta = 30^\circ$

2.  $(-5, 1), \theta = \frac{\pi}{3}$

3.  $\left(\frac{-1}{2}, \frac{-1}{8}\right), \theta = \frac{\pi}{4}$

4.  $(2.7, 5), \theta = 15^\circ$

5.  $(13, -4), \theta = 78^\circ$

6.  $\left(\frac{12}{\sqrt{18}}, \frac{240}{\sqrt{1152}}\right), \theta = 45^\circ$

7.  $\left(3.65, \frac{3}{8}\right), \theta = \frac{\pi}{6}$

8.  $\left(\frac{3+\sqrt{48}}{-(2\sqrt{12}+3)}, \frac{\sqrt{4096}}{8\sqrt{25} \cdot \frac{1}{5}\sqrt{64}}\right), \theta = \frac{\pi}{2}$

Use the discriminant to determine whether the equation of the given conic represents an ellipse, a parabola, or a hyperbola. See Example 4.

9.  $2x^2 - 3xy + 2y^2 - 2x = 0$

10.  $3x^2 + 7xy + 5y^2 - 6x + 7y + 15 = 0$

11.  $3x^2 + 8xy + 4y^2 - 7 = 0$

12.  $5x^2 + 6xy - 3y^2 - 9 = 0$

13.  $-2x^2 - 8xy + 2y^2 + 2y + 5 = 0$

14.  $3x^2 - 6xy + 3y^2 + 3x - 9 = 0$

15.  $x^2 - xy + 4y^2 + 2x - 3y + 1 = 0$

16.  $x^2 - 4xy + 4y^2 + 2x + 3y - 1 = 0$

Use the discriminant to classify each of the following conic sections. Then determine the angle  $\theta$  that will allow you to convert the equation and eliminate the  $xy$ -term. Finally, sketch the graph of the conic section. See Examples 2, 3, and 4.

17.  $xy = 2$

18.  $xy - 4 = 0$

19.  $x^2 + 2xy + y^2 - x + y = 0$

20.  $7x^2 + 5\sqrt{3}xy + 2y^2 = 14$

21.  $22x^2 + 6\sqrt{3}xy + 16y^2 - 49 = 276$

22.  $2\sqrt{3}x^2 - 6xy + \sqrt{3}x - 9y = 0$

23.  $34x^2 + 8\sqrt{3}xy + 42y^2 = 1380$

24.  $xy + x - 4y = 6$

Sketch the graphs of the following conic sections. See Examples 2, 3, and 4.

25.  $x^2 + 6xy + y^2 = 18$

26.  $x^2 - 4xy + 3y^2 = 12$

27.  $9x^2 + 14xy - 9y^2 = 15$

28.  $36x^2 - 19xy + 8y^2 = 72$

29.  $40x^2 + 20xy + 10y^2 + (2\sqrt{2} - 6)x - (4\sqrt{2} + 8)y = 90$

30.  $72x^2 + 19xy + 4y^2 = 20$

31.  $48x^2 + 15xy + 7y^2 = 28$

32.  $72x^2 + 18xy - 9y^2 = 14$

Match the equation with its corresponding graph.

33.  $3x^2 + 2xy + y^2 - 10 = 0$

34.  $x^2 - 4xy + 4y^2 + 5\sqrt{5}y + 1 = 0$

35.  $xy - 1 = 0$

36.  $x^2 + y^2 - 16x + 39 = 0$

37.  $x^2 - y^2 - 16 = 0$

38.  $3x^2 + 8xy + 4y^2 - 7 = 0$

39.  $4xy - 9 = 0$

40.  $x^2 - 6xy + 9y^2 - 2y + 1 = 0$

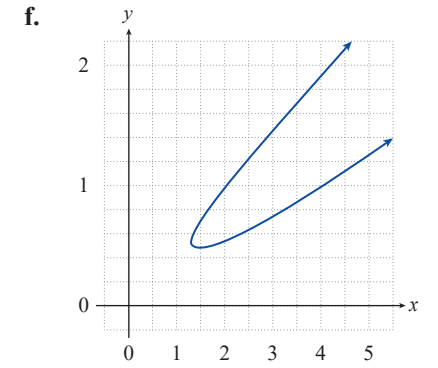
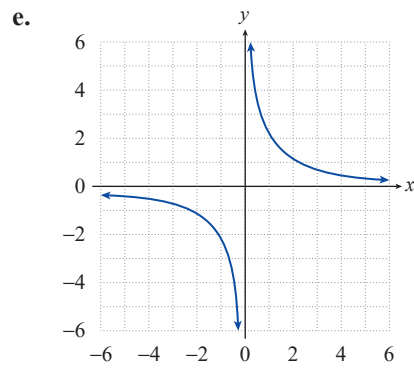
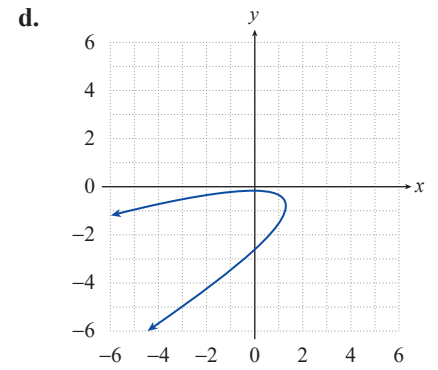
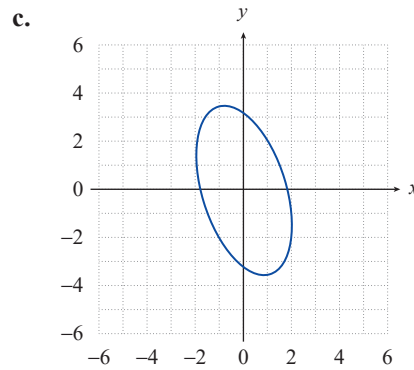
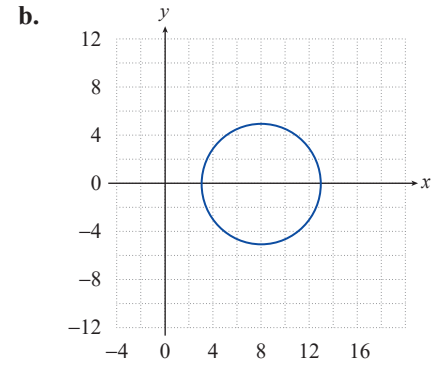
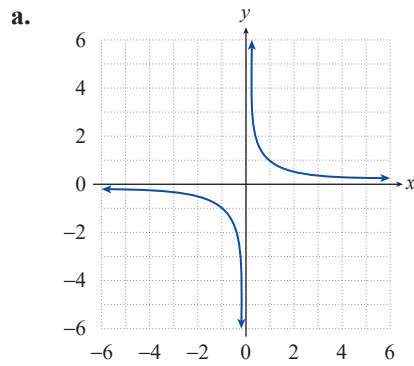

g.

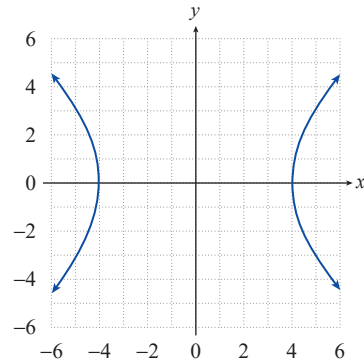

h.

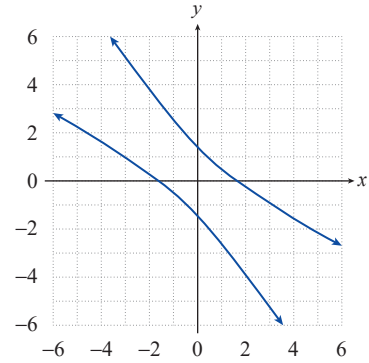

 **WRITING & THINKING**

41. You have just used the rotation of axes to rotate the  $x$ - and  $y$ -axes until they were parallel to the axes of the conic. The resulting equation in the  $x'y'$ -plane is of the form

$$A'x'^2 + Bx'y' + E'y' + F' = 0.$$

What is wrong with the resulting equation?

42. What must the angle of rotation  $\theta$  be if the coefficients of  $x^2$  and  $y^2$  are equal and  $B \neq 0$ ? Support your answer.
43. Using the equation  $7x^2 - 6\sqrt{3}xy + 13y^2 - 16 = 0$ ,
- show that the rotation invariant  $F = F'$  is true,
  - show that the rotation invariant  $A + C = A' + C'$  is true, and
  - show that the rotation invariant  $B^2 - 4AC = B'^2 - 4A'C'$  is true.

## 10.5 EXERCISES

 PRACTICE

Match the polar equation with its corresponding graph. See Examples 2 and 3.

1.  $r = \frac{3}{4 - \cos \theta}$

2.  $r = \frac{9}{6 - 2 \sin \theta}$

3.  $r = \frac{3}{3 + 4 \sin \theta}$

4.  $r = \frac{1}{2 + 2 \cos \theta}$

5.  $r = \frac{6}{1 + 3 \sin \theta}$

6.  $r = \frac{6}{1 + 3 \cos \theta}$

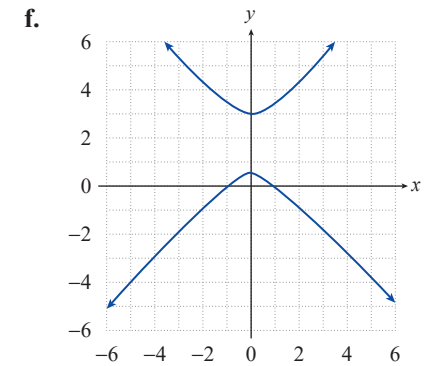
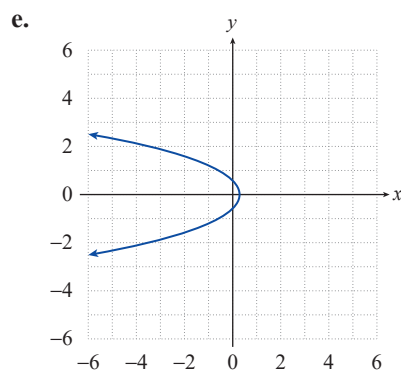
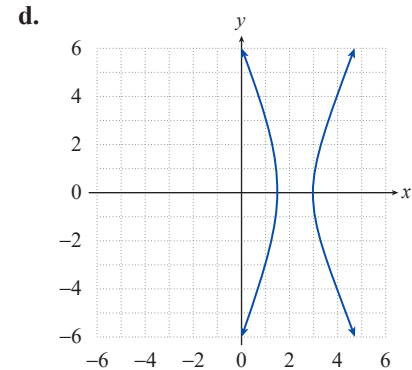
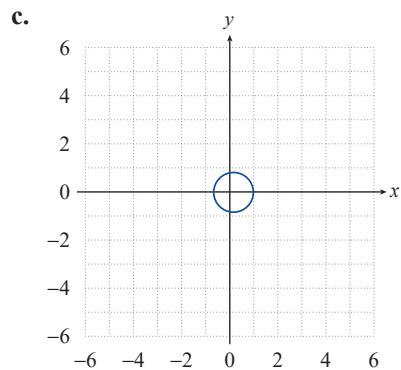
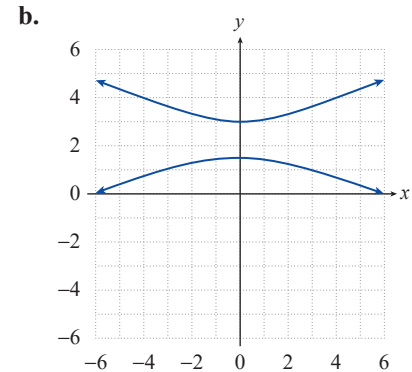
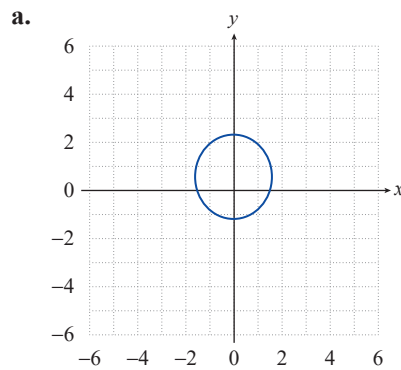

Identify each conic section and find the equation for its directrix. See Example 1.

7.  $r = \frac{7}{1+6\sin\theta}$

8.  $r = \frac{2}{1-\sin\theta}$

9.  $r = \frac{3}{4-\cos\theta}$

10.  $r = \frac{4}{2-2\cos\theta}$

11.  $r = \frac{1}{1+3\cos\theta}$

12.  $r = \frac{7}{3+2\sin\theta}$

13.  $r = \frac{5}{2+\cos\theta}$

14.  $r = \frac{3}{4-3\sin\theta}$

15.  $r = \frac{6}{3-5\cos\theta}$

16.  $r = \frac{8}{5-6\sin\theta}$

17.  $r = \frac{3}{2+2\sin\theta}$

18.  $r = \frac{-1}{3+4\cos\theta}$

19.  $r = \frac{4}{6-7\cos\theta}$

20.  $r = \frac{9}{5-4\sin\theta}$

Construct a polar equation for each conic section with the focus at the origin and the given eccentricity and directrix. See Example 2.

| Conic         | Eccentricity      | Directrix          |
|---------------|-------------------|--------------------|
| 21. Parabola  | $e = 1$           | $x = -2$           |
| 22. Hyperbola | $e = 2$           | $x = -3$           |
| 23. Hyperbola | $e = 4$           | $y = -\frac{3}{4}$ |
| 24. Parabola  | $e = 1$           | $x = 2$            |
| 25. Ellipse   | $e = \frac{1}{4}$ | $x = 12$           |
| 26. Ellipse   | $e = \frac{1}{2}$ | $y = 8$            |

Sketch the graphs of the following conic sections. See Examples 3, 4, and 5.

27.  $r = \frac{5}{1+3\cos\theta}$

28.  $r = \frac{3}{2+\sin\theta}$

29.  $r = \frac{4}{1-2\sin\theta}$

30.  $r = \frac{6}{2-4\cos\theta}$

31.  $r = \frac{9}{3-2\cos\theta}$

32.  $r = \frac{5}{3+\sin\theta}$

33.  $r = \frac{4}{1+2\cos\theta}$

34.  $r = \frac{4}{2+2\sin\theta}$

35.  $r = \frac{-3}{4-9\cos\theta}$

36.  $r = \frac{9}{-4+\frac{3}{2}\sin\theta}$

37.  $r = \frac{-11}{3-\cos\theta}$

38.  $r = \frac{2}{10+4\sin\theta}$

39.  $r = \frac{3}{7+3\cos\theta}$

40.  $r = \frac{2}{2+3\cos\left(\theta-\frac{\pi}{4}\right)}$

$$41. r = \frac{-7}{5 + 3 \sin\left(\theta - \frac{\pi}{6}\right)}$$

$$42. r = \frac{5}{-2 - 4 \sin\left(\theta + \frac{2\pi}{3}\right)}$$

$$43. r = \frac{4}{-3 - 2 \cos\left(\theta + \frac{\pi}{3}\right)}$$

$$44. r = \frac{1}{1 + 4 \sin\left(\theta + \frac{\pi}{6}\right)}$$

$$45. r = \frac{2}{1 + \cos\left(\theta - \frac{\pi}{4}\right)}$$

$$46. r = \frac{4}{2 + 2 \sin\left(\theta - \frac{\pi}{3}\right)}$$

### APPLICATIONS

47. The planets of our solar system follow elliptical orbits with the sun located at one of the foci. If we assume the sun is located at the pole and the major axes of these elliptical orbits lie along the polar axis, the orbits of the planets can be expressed by the polar equation

$$r = \frac{(1 - e^2)a}{1 - e \cos \theta},$$

where  $e$  is the eccentricity. Verify the above equation.

48. Using the equation from Exercise 47, answer the following:
- Show that the shortest distance from the sun to a planet, called the *perihelion*, is  $r = a(1 - e)$ .
  - Show that the longest distance from the sun to a planet, called the *aphelion*, is  $r = a(1 + e)$ .
  - Uranus is approximately  $2.74 \times 10^9$  km away from the sun at perihelion and  $3.00 \times 10^9$  km at aphelion. Find the eccentricity of Uranus' orbit.
  - The eccentricity of Neptune's path is 0.0113 and  $a = 4.495 \times 10^9$  km. Determine the perihelion and aphelion distances for Neptune.

## 11.1 EXERCISES

 PRACTICE

Use the method of substitution to solve the following systems of equations. If a system is dependent, express the solution set in terms of one of the variables. See Examples 1 and 2.

1. 
$$\begin{cases} 2x - y = -12 \\ 3x + y = -13 \end{cases}$$

2. 
$$\begin{cases} 2x - 4y = -6 \\ 3x - y = -4 \end{cases}$$

3. 
$$\begin{cases} 3y = 9 \\ x + 2y = 11 \end{cases}$$

4. 
$$\begin{cases} -3x - y = 2 \\ 9x + 3y = -6 \end{cases}$$

5. 
$$\begin{cases} 2x + y = -2 \\ -4x - 2y = 5 \end{cases}$$

6. 
$$\begin{cases} 5x - y = -21 \\ 9x + 2y = -34 \end{cases}$$

7. 
$$\begin{cases} 2x - y = -3 \\ -4x + 2y = 6 \end{cases}$$

8. 
$$\begin{cases} 3x + 6y = -12 \\ 2x + 4y = -8 \end{cases}$$

9. 
$$\begin{cases} 2x + 5y = 33 \\ 3x = -3 \end{cases}$$

10. 
$$\begin{cases} 5x + 2y = 8 \\ 2x + y = 6 \end{cases}$$

11. 
$$\begin{cases} -2x + y = 5 \\ 9x - 2y = 5 \end{cases}$$

12. 
$$\begin{cases} 3x + y = 4 \\ -2x + 3y = 1 \end{cases}$$

13. 
$$\begin{cases} 4x - y = -1 \\ -8x + 2y = 2 \end{cases}$$

14. 
$$\begin{cases} 4x - 2y = 3 \\ -2x + y = -7 \end{cases}$$

15. 
$$\begin{cases} 9x - y = -1 \\ 3x + 2y = 44 \end{cases}$$

Use the method of elimination to solve the following systems of equations. If a system is dependent, express the solution set in terms of one of the variables. See Examples 3 and 4.

16. 
$$\begin{cases} 2x - 3y = 8 \\ 8x + 5y = -2 \end{cases}$$

17. 
$$\begin{cases} -2x + 3y = 13 \\ 4x + 2y = -18 \end{cases}$$

18. 
$$\begin{cases} 5x + 7y = 1 \\ -2x + 3y = -12 \end{cases}$$

19. 
$$\begin{cases} x + 2y = 17 \\ 3x + 4y = 39 \end{cases}$$

20. 
$$\begin{cases} 5x - 10y = 9 \\ -x + 2y = -3 \end{cases}$$

21. 
$$\begin{cases} -2x - 2y = 4 \\ 3x + 3y = -6 \end{cases}$$

22. 
$$\begin{cases} 4x + y = 11 \\ 3x - 2y = 0 \end{cases}$$

23. 
$$\begin{cases} 7x + 8y = -3 \\ -5x - 4y = 9 \end{cases}$$

24. 
$$\begin{cases} -2x - y = 9 \\ 4x + 2y = 1 \end{cases}$$

25. 
$$\begin{cases} -2x + 4y = 6 \\ 3x - y = -4 \end{cases}$$

26. 
$$\begin{cases} 5x - 6y = -1 \\ -4x + 3y = -10 \end{cases}$$

27. 
$$\begin{cases} \frac{2}{3}x + y = -3 \\ 3x + \frac{5}{2}y = -\frac{7}{2} \end{cases}$$

28. 
$$\begin{cases} \frac{x}{5} - y = -\frac{11}{5} \\ \frac{x}{4} + y = 4 \end{cases}$$

29. 
$$\begin{cases} \frac{2}{3}x + 2y = 1 \\ x + 3y = 0 \end{cases}$$

30. 
$$\begin{cases} -x - 5y = -6 \\ \frac{3}{5}x + 3y = 1 \end{cases}$$

Use any convenient method to solve the following systems of equations. If a system is dependent, express the solution set in terms of one or more of the variables, as appropriate. See Examples 5 and 6.

$$31. \begin{cases} x - y + 4z = -4 \\ 4x + y - 2z = -1 \\ -y + 2z = -3 \end{cases}$$

$$32. \begin{cases} x + 2y = -1 \\ y + 3z = 7 \\ 2x + 5z = 21 \end{cases}$$

$$33. \begin{cases} x + y = 4 \\ y + 3z = -1 \\ 2x - 2y + 5z = -5 \end{cases}$$

$$34. \begin{cases} 2x - y = 0 \\ 5x - 3y - 3z = 5 \\ 2x + 6z = -10 \end{cases}$$

$$35. \begin{cases} 3x - y + z = 2 \\ -6x + 2y - 2z = -4 \\ -3x + y - z = -2 \end{cases}$$

$$36. \begin{cases} 2x - 3y = -2 \\ x - 4y + 3z = 0 \\ -2x + 7y - 5z = 0 \end{cases}$$

$$37. \begin{cases} 3x - y + z = 2 \\ -6x + 2y - 2z = 1 \\ 5x + 2y - 3z = 2 \end{cases}$$

$$38. \begin{cases} 4x - y + 5z = 6 \\ 4x - 3y - 5z = -14 \\ -2x - 5z = -8 \end{cases}$$

$$39. \begin{cases} 3x + 8z = 3 \\ -3x + y - 7z = -2 \\ x + 2y + 3z = 3 \end{cases}$$

$$40. \begin{cases} x + 2y + z = 8 \\ 2x - 3y - 4z = -16 \\ x - 5y + 5z = 6 \end{cases}$$

$$41. \begin{cases} 2x - 7y - 4z = 7 \\ -x + 4y + 2z = -3 \\ 3y - 4z = -1 \end{cases}$$

$$42. \begin{cases} 4x + 4y - 2z = 6 \\ x - 5y + 3z = -2 \\ -2x - 2y + z = 3 \end{cases}$$

$$43. \begin{cases} 2x + 3y + 4z = 1 \\ 3x - 4y + 5z = -5 \\ 4x + 5y + 6z = 5 \end{cases}$$

$$44. \begin{cases} x - 4y + 2z = -1 \\ 2x + y - 3z = 10 \\ -3x + 12y - 6z = 3 \end{cases}$$

$$45. \begin{cases} x + 2y + 3z = 29 \\ 2x - y - z = -2 \\ 3x + 2y - 6z = -8 \end{cases}$$

$$46. \begin{cases} 5x - 2y + z = 14 \\ 8x + 4y = 12 \\ 9x = 18 \end{cases}$$

$$47. \begin{cases} 2x + 5y = 6 \\ 3y + 8z = -6 \\ x + 4y = -5 \end{cases}$$

$$48. \begin{cases} 4x + 3y + 4z = 5 \\ 5x - 6y - 2z = -12 \\ 5z = 20 \end{cases}$$

$$49. \begin{cases} 9x + 4y - 8z = -4 \\ -6x + 3y - 9z = -9 \\ 8y - 3z = 18 \end{cases}$$

$$50. \begin{cases} 21x - 7y + 51z = 141 \\ 13x + 9y - 5z = -19 \\ 19x - 8y + 23z = 30 \end{cases}$$

 APPLICATIONS

51. Karen empties out her purse and finds 45 loose coins, consisting entirely of nickels and pennies. If the total value of the coins is \$1.37, how many nickels and how many pennies does she have?
52. What choice of  $a$ ,  $b$ , and  $c$  will force the graph of the polynomial  $f(x) = ax^2 + bx + c$  to have a  $y$ -intercept of 5 and to pass through the points  $(1,3)$  and  $(2,0)$ ?
53. A tour organizer is planning on taking a group of 40 people to a musical. Balcony tickets cost \$29.95 and regular tickets cost \$19.95. The organizer collects a total of \$1048.00 from her group to buy the tickets. How many people chose to sit in the balcony?
54. How many ounces each of a 12% alcohol solution and a 30% alcohol solution must be combined to obtain 60 ounces of an 18% solution?
55. Eliza's mother is 20 years older than Eliza, but 3 years younger than Eliza's father. Eliza's father is 7 years younger than three times Eliza's age. How old is Eliza?
56. An investor decides at the beginning of the year to invest some of his cash in an account paying 8% annual interest, and to put the rest in a stock fund that ends up earning 15% over the course of the year. He puts \$2000 more in the first account than in the stock fund, and at the end of the year he finds he has earned \$1310 in interest. How much money was invested at each of the two rates?
57. Jack and Tyler went shopping for summer clothes. Shirts were \$12.47 each, including tax, and shorts were \$17.23 per pair, including tax. Jack and Tyler spent a total of \$156.21 on 11 items. How many shirts and pairs of shorts did they buy?
58. Three years ago, Bob was twice as old as Marla. Fifteen years ago, Bob was three times as old as Marla. How old is Bob?
59. Deyanira empties her pockets and finds 42 coins consisting of quarters, dimes, and pennies. There are twice as many pennies as dimes and quarters total. If the total value of the coins is \$2.13, how many coins of each denomination does she have?
60. If an investor has invested \$1000 in stocks and bonds, how much has he invested in stocks if he invested four times more in stocks than in bonds?
61. Twelve years ago, Jim was twice as old as Kristin. Sixteen years ago, Jim was three times older than Kristin. How old is Jim?
62. A movie brought in \$740 in ticket sales in one day. Tickets during the day cost \$5 and tickets at night cost \$7. If 120 tickets were sold, how many were sold during the day?
63. A computer has 24 screws in its case. If there are 7 times more slotted screws than thumb screws, how many thumb screws are in the computer?

64. Jael has \$10,000 she would like to invest. She has narrowed her options down to a certificate of deposit paying 5% annually, bonds paying 4% annually, and stocks with an expected annual rate of return of 13.5%. If she wants to invest twice as much in the stocks as in the certificate of deposit and she wants to earn \$1000 in interest by the end of the year, how much should she invest in each type of investment?
65. Lea ordered fruit baskets for three of her coworkers. One contained 5 apples, 2 oranges, and 1 mango and cost \$6.81. Another contained 2 mangos, 8 oranges, and 3 apples and cost \$11.88. The third contained 4 apples, 4 oranges, and 4 mangos and cost \$11.04. How much did each type of fruit cost?

 TECHNOLOGY

Solve each of the following systems of equations using a graphing utility.

$$66. \begin{cases} 98x + 43y - 82z = -784 \\ -65x + 34y = 3032 \\ 28y - 13z = 966 \end{cases}$$

$$67. \begin{cases} 7.5x + 5.2y - 9.3z = -23.971 \\ -6.8x + 4.4y = 2.708 \\ 0.9x - 1.88y = -2.0194 \end{cases}$$

$$68. \begin{cases} -5x + 2y - 20z = 14 \\ 2x - 3y + 10z = -19 \\ 7x + 4y - 7z = -7 \end{cases}$$

$$69. \begin{cases} -5.5x + 2.2y - 5.1z = 11.29 \\ 1.8x + 4.9y - 0.5z = 7.066 \\ 3.9x - 2.6y + 6.3z = -3.698 \end{cases}$$

$$70. \begin{cases} 5x - 10y + 11z = 19 \\ 27x + 9y + 7z = -44 \\ 2x + 19y - 4z = -3 \end{cases}$$

$$71. \begin{cases} -23x + 17y - 7z = -51 \\ -13x + 25y - 11z = 45 \\ 51x - 21y - 28z = -58 \end{cases}$$

## 11.2 EXERCISES

### PRACTICE

- Let  $A = \begin{bmatrix} 4 & -1 \\ 0 & 3 \\ 9 & -5 \end{bmatrix}$ . Determine the following, if possible:
  - The order of  $A$
  - The value of  $a_{12}$
  - The value of  $a_{23}$
- Let  $B = [-7 \ 2 \ 11]$ . Determine the following, if possible:
  - The order of  $B$
  - The value of  $b_{12}$
  - The value of  $b_{31}$
- Let  $C = \begin{bmatrix} 1 & 0 \\ 5 & -3 \\ 2 & 9 \\ \pi & e \\ 10 & -7 \end{bmatrix}$ . Determine the following, if possible:
  - The order of  $C$
  - The value of  $c_{23}$
  - The value of  $c_{51}$
- Let  $D = \begin{bmatrix} -8 & 13 & -1 \\ 0 & 6 & 3 \\ 0 & -9 & 0 \end{bmatrix}$ . Determine the following, if possible:
  - The order of  $D$
  - The value of  $d_{23}$
  - The value of  $d_{33}$
- Let  $E = \begin{bmatrix} -443 & 951 & 165 & 274 \\ 286 & -653 & 812 & -330 \\ 909 & 377 & 429 & -298 \end{bmatrix}$ . Determine the following, if possible:
  - The order of  $E$
  - The value of  $e_{42}$
  - The value of  $e_{21}$
- Let  $A = \begin{bmatrix} 9 & 5 & 0 \\ 7 & 4 & 2 \end{bmatrix}$ . Determine the following, if possible:
  - The order of  $A$
  - The value of  $a_{22}$
  - The value of  $a_{13}$
- Let  $B = \begin{bmatrix} 8 & 1 \\ 3 & 0 \\ 6 & 7 \end{bmatrix}$ . Determine the following, if possible:
  - The order of  $B$
  - The value of  $b_{12}$
  - The value of  $b_{13}$
- Let  $C = \begin{bmatrix} 65 & 32 & 91 & 45 \\ 23 & 18 & 75 & 47 \\ 8 & 63 & 28 & 31 \end{bmatrix}$ . Determine the following, if possible:
  - The order of  $C$
  - The value of  $c_{43}$
  - The value of  $c_{23}$

9. Let  $D = \begin{bmatrix} 4 & 9 & 7 & 1 & 8 \\ 5 & 3 & 0 & 2 & 6 \end{bmatrix}$ . Determine the following, if possible:

- a. The order of  $D$       b. The value of  $d_{21}$       c. The value of  $d_{24}$

Construct the augmented matrix that corresponds to each of the following systems of equations. See Example 2. (Answers may appear in slightly different, but equivalent, form.)

10. 
$$\begin{cases} 4x + 5y - 3z = 8 \\ 7x - 2y + 9 = 3 \\ 5x - 6y + 3z = 0 \end{cases}$$

11. 
$$\begin{cases} y - 2z + 4 = 3x \\ \frac{x}{2} - 4y - 1 = z \\ 3(-y + z) - 1 = 0 \end{cases}$$

12. 
$$\begin{cases} 5x + \frac{y-z}{2} = 3 \\ 7(z-x) + y - 2 = 0 \\ x - (4-z) = y \end{cases}$$

13. 
$$\begin{cases} \frac{2-3x}{2} = y \\ 3z + 2(x+y) = 0 \\ 2x - y = 2(x-3z) \end{cases}$$

14. 
$$\begin{cases} 2(z+3) - x + y = z \\ -3(x-2y) - 1 = 5z \\ \frac{x}{3} - (y-2z) = x \end{cases}$$

15. 
$$\begin{cases} \frac{12x-1}{5} + \frac{y}{2} = \frac{3z}{2} \\ y - (x+3z) = -(1-y) \\ 2x - 2 - z - 2y = 7x \end{cases}$$

16. 
$$\begin{cases} \frac{3x+4y}{2} - 3z = 6 \\ 3(x-2y+9z) = 0 \\ 2x+6y = 3-z \end{cases}$$

17. 
$$\begin{cases} \frac{2x-4y}{3} = 2z \\ 8x = 2(y-3z) + 7 \\ 3x = 2y \end{cases}$$

18. 
$$\begin{cases} \frac{2(2x-y)}{3} + z = 7 \\ 4 = \frac{3}{-x+y+3z} \\ 4x - 8y + 4 = 9x \end{cases}$$

19. 
$$\begin{cases} 0.5x - 14y = \frac{z}{4} - 8 \\ \frac{x}{5} - y + \frac{z}{4} = \frac{y}{6} - 3 \\ \frac{2}{3} \left( \frac{4}{y-x-1} \right) = \frac{5}{z} \end{cases}$$

Construct the system of equations that corresponds to each of the following matrices.

20. 
$$\left[ \begin{array}{cc|c} 5 & 3 & 9 \\ 1 & 4 & 12 \end{array} \right]$$

21. 
$$\left[ \begin{array}{cc|c} 1 & 0 & 8 \\ 0 & 1 & 3 \end{array} \right]$$

22. 
$$\left[ \begin{array}{ccc|c} 14 & 0 & 1 & 16 \\ 3 & 6 & 4 & 0 \\ 8 & 2 & 5 & 21 \end{array} \right]$$

23. 
$$\left[ \begin{array}{ccc|c} 1 & 3 & 6 & 16 \\ 0 & 1 & 2 & 9 \\ 0 & 0 & 1 & 4 \end{array} \right]$$

24. 
$$\left[ \begin{array}{ccc|c} 2 & 1 & 1 & 22 \\ 1 & 3 & 1 & 17 \\ 1 & 1 & 4 & 8 \end{array} \right]$$

25. 
$$\left[ \begin{array}{ccc|c} 0 & 9 & 13 & 27 \\ 2 & 0 & 21 & 19 \\ 7 & 18 & 0 & 32 \end{array} \right]$$

Fill in the blanks by performing the indicated row operations. See Example 4.

26. 
$$\left[ \begin{array}{cc|c} 3 & 2 & -7 \\ 1 & 3 & 5 \end{array} \right] \xrightarrow{-3R_2+R_1} \underline{\quad}$$

27. 
$$\left[ \begin{array}{cc|c} 2 & -5 & 3 \\ -4 & 3 & -1 \end{array} \right] \xrightarrow{2R_1+R_2} \underline{\quad}$$

$$28. \left[ \begin{array}{cc|c} 4 & 2 & -8 \\ 3 & -9 & 0 \end{array} \right] \xrightarrow{\substack{\frac{1}{2}R_1 \\ \frac{1}{3}R_2}} ?$$

$$29. \left[ \begin{array}{cc|c} 9 & -2 & 7 \\ 1 & 3 & -2 \end{array} \right] \xrightarrow{R_1 \leftrightarrow R_2} ?$$

$$30. \left[ \begin{array}{cc|c} 4 & 1 & 5 \\ 3 & 6 & 0 \end{array} \right] \xrightarrow{2R_1} ?$$

$$31. \left[ \begin{array}{cc|c} 8 & -2 & -4 \\ 3 & -1 & 7 \end{array} \right] \xrightarrow{-2R_2} ?$$

$$32. \left[ \begin{array}{cc|c} 9 & 12 & -6 \\ 15 & -3 & 0 \end{array} \right] \xrightarrow{-\frac{1}{3}R_1} ?$$

$$33. \left[ \begin{array}{cc|c} 4 & 12 & -6 \\ 7 & 3 & 9 \end{array} \right] \xrightarrow{\frac{1}{2}R_1 + R_2} ?$$

$$34. \left[ \begin{array}{cc|c} 3 & 0 & 1 \\ 5 & 7 & -2 \end{array} \right] \xrightarrow{3R_1 + R_2} ?$$

$$35. \left[ \begin{array}{cc|c} 8 & -2 & 10 \\ 9 & -3 & 0 \end{array} \right] \xrightarrow{\substack{\frac{1}{2}R_1 \\ -\frac{2}{3}R_2}} ?$$

$$36. \left[ \begin{array}{ccc|c} 5 & 2 & 9 & 7 \\ 1 & 3 & -5 & 0 \\ 2 & -4 & 1 & 8 \end{array} \right] \xrightarrow{\substack{2R_2 \\ -R_1 + R_3}} ?$$

$$37. \left[ \begin{array}{ccc|c} 6 & -2 & 5 & 14 \\ -7 & 19 & 2 & 3 \\ -9 & 11 & -4 & 7 \end{array} \right] \xrightarrow{\substack{3R_1 \\ 0.5R_3}} ?$$

$$38. \left[ \begin{array}{ccc|c} 5 & 3 & 13 & 15 \\ 17 & 9 & -8 & -14 \\ 4 & -11 & 19 & 8 \end{array} \right] \xrightarrow{-2R_2 + R_3} ?$$

$$39. \left[ \begin{array}{ccc|c} 8 & 11 & 18 & 2 \\ 14 & 33 & -3 & -5 \\ -9 & 21 & 12 & 9 \end{array} \right] \xrightarrow{\substack{\frac{1}{3}R_3 + R_1 \\ -2R_3 + R_2}} ?$$

$$40. \left[ \begin{array}{ccc|c} 1 & 3 & -2 & 4 \\ 3 & -1 & 8 & 2 \\ -5 & 0 & 2 & 7 \end{array} \right] \xrightarrow{\substack{-3R_1 + R_2 \\ 5R_1 + R_3}} ?$$

$$41. \left[ \begin{array}{ccc|c} 2 & 3 & -3 & 5 \\ 1 & 1 & 3 & 4 \\ 3 & 3 & 9 & 12 \end{array} \right] \xrightarrow{\substack{-2R_2 + R_1 \\ -3R_2 + R_3}} ?$$

$$42. \left[ \begin{array}{cc|c} -3 & 2 & 2 \\ 5 & -4 & 1 \end{array} \right] \xrightarrow{2R_1 + R_2} ?$$

$$43. \left[ \begin{array}{cc|c} -5 & 20 & -15 \\ 2 & -12 & 5 \end{array} \right] \xrightarrow{\substack{\frac{1}{5}R_1 \\ \frac{1}{2}R_2}} ?$$

$$44. \left[ \begin{array}{ccc|c} 2 & 2 & 3 & 7 \\ -3 & 2 & 8 & -2 \\ 1 & 5 & 2 & 6 \end{array} \right] \xrightarrow{\substack{-2R_3 + R_1 \\ 3R_3 + R_2}} ?$$

$$45. \left[ \begin{array}{ccc|c} 1 & 5 & -9 & 11 \\ 1 & 4 & -1 & 4 \\ 4 & 3 & 5 & 45 \end{array} \right] \xrightarrow{\substack{-R_1 + R_2 \\ -4R_1 + R_3}} ?$$

For each matrix, determine if it is in row echelon form, reduced row echelon form, or neither.

$$46. \left[ \begin{array}{cc|c} 1 & 5 & 4 \\ 0 & 1 & 3 \end{array} \right]$$

$$47. \left[ \begin{array}{ccc|c} 1 & 2 & 0 & 9 \\ 0 & 1 & 3 & 4 \\ 0 & 1 & 1 & 12 \end{array} \right]$$

$$48. \left[ \begin{array}{ccc|c} 1 & 0 & 0 & 4 \\ 0 & 1 & 0 & 1 \\ 0 & 0 & 1 & 8 \end{array} \right]$$

$$49. \left[ \begin{array}{ccc|c} 1 & 0 & 0 & 7 \\ 5 & 1 & 0 & 14 \\ 3 & 4 & 1 & -16 \end{array} \right]$$

$$50. \left[ \begin{array}{ccc|c} 1 & 2 & 5 & 0 \\ 0 & 1 & 9 & 3 \\ 0 & 0 & 0 & 1 \end{array} \right]$$

$$51. \left[ \begin{array}{cc|c} 0 & 1 & 3 \\ 1 & 0 & 6 \end{array} \right]$$

Use Gaussian elimination and back-substitution to solve the following systems of equations. See Example 5.

$$52. \begin{cases} 2x - 4y = -6 \\ 3x - y = -4 \end{cases} \quad 53. \begin{cases} 2x - 5y = 11 \\ 3x + 2y = 7 \end{cases} \quad 54. \begin{cases} 5x - y = -21 \\ 9x + 2y = -34 \end{cases}$$

$$55. \begin{cases} x - 4y = -11 \\ 7x - y = 4 \end{cases} \quad 56. \begin{cases} x + 2y = 17 \\ 3x + 4y = 39 \end{cases} \quad 57. \begin{cases} 2x + 6y = 4 \\ -4x - 7y = 7 \end{cases}$$

$$58. \begin{cases} 3x - 2y = 5 \\ -5x + 4y = -3 \end{cases} \quad 59. \begin{cases} 2x + y = -2 \\ -4x - 2y = 5 \end{cases} \quad 60. \begin{cases} 6x - 16y = 10 \\ -3x + 8y = 4 \end{cases}$$

$$61. \begin{cases} 2x - 3y = 0 \\ 5x + y = 17 \end{cases} \quad 62. \begin{cases} 6x + 3y = 3 \\ x + y = 3 \end{cases} \quad 63. \begin{cases} 3x + 6y = -12 \\ 2x + 4y = -8 \end{cases}$$

$$64. \begin{cases} 4x + 5y = 9 \\ 8x + 3y = -17 \end{cases} \quad 65. \begin{cases} \frac{2}{3}x + 2y = 1 \\ x + 3y = 0 \end{cases} \quad 66. \begin{cases} 13x - 17y = -3 \\ -19x + 15y = -35 \end{cases}$$

$$67. \begin{cases} 3x - 9y - 7z = -9 \\ 5x + 11y - z = 17 \\ -4x - 8y + 7z = 5 \end{cases} \quad 68. \begin{cases} 8x - y + 5z = -8 \\ 11x - 2y + 9z = -9 \\ 7x - 3y + 13z = 4 \end{cases} \quad 69. \begin{cases} 17x + 13y + 8z = 46 \\ -12x + 3y + 28z = -19 \\ 14x + 5y - 15z = -15 \end{cases}$$

Use Gauss-Jordan elimination to solve the following systems of equations. See Example 6.

$$70. \begin{cases} 2x - 3y = 8 \\ 8x + 5y = -2 \end{cases} \quad 71. \begin{cases} \frac{2}{3}x + y = -3 \\ 3x + \frac{5}{2}y = -\frac{7}{2} \end{cases} \quad 72. \begin{cases} 3y = 9 \\ x + 2y = 11 \end{cases}$$

$$73. \begin{cases} 6x + 2y = -4 \\ -9x - 3y = 6 \end{cases} \quad 74. \begin{cases} 3y = 6 \\ 5x + 2y = 4 \end{cases} \quad 75. \begin{cases} 3x + 8y = -4 \\ x + 2y = -2 \end{cases}$$

$$76. \begin{cases} -3x + 2y = 5 \\ 5x - 2y = 1 \end{cases} \quad 77. \begin{cases} 9x - 11y = 10 \\ -4x + 3y = -12 \end{cases} \quad 78. \begin{cases} 9x - 15y = -6 \\ -3x + 11y = -10 \end{cases}$$

$$79. \begin{cases} 3x - 8y = 7 \\ 18x - 35y = -23 \end{cases} \quad 80. \begin{cases} 4x + y - 3z = -9 \\ 2x - 3z = -19 \\ 7x - y - 4z = -29 \end{cases} \quad 81. \begin{cases} -5x + 9y + 3z = 1 \\ 3x + 2y - 6z = 9 \\ x + 4y - z = 16 \end{cases}$$

$$82. \begin{cases} 2x - y = 0 \\ 5x - 3y - 3z = 5 \\ 2x + 6z = -10 \end{cases} \quad 83. \begin{cases} x + y = 4 \\ y + 3z = -1 \\ 2x - 2y + 5z = -5 \end{cases} \quad 84. \begin{cases} 2x - 3y = -2 \\ x - 4y + 3z = 0 \\ -2x + 7y - 5z = 0 \end{cases}$$

$$85. \begin{cases} 3x + 8z = 3 \\ -3x - 7z = -3 \\ x + 3z = 1 \end{cases} \quad 86. \begin{cases} 3x - y + z = 2 \\ -6x + 2y - 2z = 1 \\ 5x + 2y - 3z = 2 \end{cases} \quad 87. \begin{cases} x + 2y = -1 \\ y + 3z = 7 \\ 2x + 5z = 21 \end{cases}$$

$$88. \begin{cases} 2x + 8y - z = -5 \\ -5x + 3y + 4z = -6 \\ x - 4y - 5z = -8 \end{cases}$$

$$90. \begin{cases} 8x + 14y - 3z = 3 \\ -6x + 2y + 7z = -13 \\ 8x + 19y + 3z = 11 \end{cases}$$

$$92. \begin{cases} 4x + 8y + 7z = 27 \\ -2x + 9y - 8z = -15 \\ 9x + 13y + 7z = -33 \end{cases}$$

$$94. \begin{cases} 3w - x + 5y + 3z = 2 \\ -4w - 10y - 2z = 10 \\ w - x + 2z = 7 \\ 4w - 2x + 5y + 5z = 9 \end{cases}$$

$$89. \begin{cases} 7x - 8y + 2z = -2 \\ 5x - 3y - z = -3 \\ 8x + y - 3z = 7 \end{cases}$$

$$91. \begin{cases} 8x + 5y + 3z = -2 \\ 12x - y - 18z = 1 \\ 7x + 6y + 10z = 19 \end{cases}$$

$$93. \begin{cases} w - x + 2z = 9 \\ 2w + 3y = -1 \\ -2w - 5y - z = 0 \\ x + 2y = -4 \end{cases}$$

### APPLICATIONS

95. The sum of three integers is 155. The first integer is sixteen more than the second. The third integer is seven less than the sum of the first integer and twice the second. What are the three integers?
96. Mario bought a pound of bacon, a dozen eggs, and a loaf of bread to make breakfast for his family. The total cost was \$7.42. The bacon cost \$0.03 more than twice the price of the bread and the eggs cost \$0.03 less than half the price of the bread. Find the price of each item.
97. The Pizza House sells three sizes of pizzas: small, medium, large. The prices of the pizzas are \$9.00, \$12.00, and \$15.00, respectively. In one day, they sold 82 pizzas for a total of \$1098.00. If the number of large pizzas sold was twice the number of medium pizzas sold, how many of each size pizza did the Pizza House sell?

Note that we have used the first property of determinants to factor  $x_1$  out of the determinant. We can now solve this equation for  $x_1$  (since  $D \neq 0$ ) to obtain

$$x_1 = \frac{D_{x_1}}{D},$$

and we can then repeat the process for the remaining variables  $x_2, x_3, \dots, x_n$ .

## 11.3 EXERCISES

### PRACTICE

Evaluate each of the following determinants. See Example 1.

1.  $\begin{vmatrix} 4 & -3 \\ 1 & 2 \end{vmatrix}$

2.  $\begin{vmatrix} 5 & -2 \\ 5 & -2 \end{vmatrix}$

3.  $\begin{vmatrix} 0 & 3 \\ -5 & 2 \end{vmatrix}$

4.  $\begin{vmatrix} 34 & -2 \\ 17 & -1 \end{vmatrix}$

5.  $\begin{vmatrix} a & x \\ x & b \end{vmatrix}$

6.  $\begin{vmatrix} 5x & 2 \\ -x & 1 \end{vmatrix}$

7.  $\begin{vmatrix} -2 & 2 \\ -2 & -2 \end{vmatrix}$

8.  $\begin{vmatrix} ac & 2ad \\ bc & db \end{vmatrix}$

9.  $\begin{vmatrix} -1 & 2 \\ 3 & 4 \end{vmatrix}$

10.  $\begin{vmatrix} w & x \\ y & z \end{vmatrix}$

11.  $\begin{vmatrix} -2 & 9 \\ 5 & -3 \end{vmatrix}$

12.  $\begin{vmatrix} 2y & 3x \\ y-1 & x^2 \end{vmatrix}$

Solve for  $x$  by calculating the determinant.

13.  $\begin{vmatrix} x-2 & 2 \\ 2 & x+1 \end{vmatrix} = 0$

14.  $\begin{vmatrix} x+7 & -2 \\ 9 & x-2 \end{vmatrix} = 0$

15.  $\begin{vmatrix} x+1 & 8 \\ 1 & x+3 \end{vmatrix} = 0$

16.  $\begin{vmatrix} x-8 & 11 \\ -2 & x+5 \end{vmatrix} = 0$

17.  $\begin{vmatrix} x+6 & 2 \\ -1 & x+3 \end{vmatrix} = 0$

18.  $\begin{vmatrix} x-4 & -4 \\ 3 & x+9 \end{vmatrix} = 0$

19.  $\begin{vmatrix} x+5 & 3 \\ 3 & x-3 \end{vmatrix} = 0$

20.  $\begin{vmatrix} x+3 & 6 \\ 5 & x+7 \end{vmatrix} = 0$

21.  $\begin{vmatrix} x-3 & 2 \\ 1 & x-4 \end{vmatrix} = 0$

Use the matrix  $A = \begin{bmatrix} 2 & -1 & 5 \\ 0 & 1 & 3 \\ 1 & 0 & -2 \end{bmatrix}$  to evaluate the following. See Example 2.

22. The minor of  $a_{12}$

23. The cofactor of  $a_{12}$

24. The minor of  $a_{22}$

25. The cofactor of  $a_{22}$

26. The cofactor of  $a_{32}$

27. The cofactor of  $a_{33}$

28. The minor of  $a_{13}$

29. The cofactor of  $a_{21}$

30. The cofactor of  $a_{31}$

Find the determinant by the method of expansion by cofactors along the given row or column. See Example 3.

$$31. \begin{vmatrix} 4 & 5 & 3 \\ -1 & 2 & 7 \\ 11 & 6 & 2 \end{vmatrix} \text{ Expand along Row 3} \qquad 32. \begin{vmatrix} 8 & 2 & 0 \\ 3 & 4 & 7 \\ 1 & 0 & 2 \end{vmatrix} \text{ Expand along Column 3}$$

$$33. \begin{vmatrix} 5 & 8 & 5 \\ 0 & -6 & 3 \\ 2 & 4 & -1 \end{vmatrix} \text{ Expand along Row 2} \qquad 34. \begin{vmatrix} -4 & 2 & 1 \\ 9 & 12 & 8 \\ 0 & 6 & -3 \end{vmatrix} \text{ Expand along Column 1}$$

$$35. \begin{vmatrix} 13 & 0 & -7 \\ 4 & 2 & 3 \\ 1 & 4 & 0 \end{vmatrix} \text{ Expand along Row 2} \qquad 36. \begin{vmatrix} 7 & 0 & 1 \\ 2 & 5 & 3 \\ 8 & 6 & 2 \end{vmatrix} \text{ Expand along Column 3}$$

$$37. \begin{vmatrix} 8 & 0 & -7 & 5 \\ 4 & -2 & 3 & 3 \\ -1 & 1 & 0 & 2 \\ 2 & 0 & 6 & 0 \end{vmatrix} \text{ Expand along Row 4} \qquad 38. \begin{vmatrix} 4 & -2 & 9 & 2 \\ 7 & 0 & 1 & 7 \\ -6 & 3 & 0 & 1 \\ 3 & 1 & 2 & 0 \end{vmatrix} \text{ Expand along Column 2}$$

Evaluate each of the following determinants. In each case, minimize the required number of computations by carefully choosing a row or column to expand along, and use the properties of determinants to simplify the process. See Examples 3 and 4.

$$39. \begin{vmatrix} 2 & 0 & 1 \\ -5 & 1 & 0 \\ 3 & -1 & 1 \end{vmatrix} \qquad 40. \begin{vmatrix} 12 & 3 & 1 \\ 1 & 1 & -1 \\ 0 & 2 & 0 \end{vmatrix} \qquad 41. \begin{vmatrix} 12 & 3 & 6 \\ 2 & 2 & -4 \\ 0 & 2 & 0 \end{vmatrix}$$

$$42. \begin{vmatrix} 1 & 2 & 3 \\ 4 & 5 & 6 \\ 7 & 8 & 9 \end{vmatrix} \qquad 43. \begin{vmatrix} 2 & 1 & -3 & 0 \\ 1 & -2 & 1 & 0 \\ 0 & 1 & 0 & 1 \\ 2 & 0 & 1 & 1 \end{vmatrix} \qquad 44. \begin{vmatrix} x & 0 & 0 & 0 \\ 0 & x & 0 & 0 \\ 0 & 0 & x & 0 \\ 0 & 0 & 0 & x \end{vmatrix}$$

$$45. \begin{vmatrix} x & x & x & x \\ 0 & x & x & x \\ 0 & 0 & x & x \\ 0 & 0 & 0 & x \end{vmatrix} \qquad 46. \begin{vmatrix} 0 & 2 & 0 & 0 \\ -2 & -4 & 5 & 9 \\ 1 & 3 & -1 & 1 \\ 0 & 7 & 0 & 2 \end{vmatrix} \qquad 47. \begin{vmatrix} x & x & 0 & 0 \\ yz & x^3 & z & x^4 \\ z & xy & x & 0 \\ x^2 & 0 & 0 & 0 \end{vmatrix}$$

Use Cramer's Rule to solve each system of equations. See Examples 5 and 6.

$$48. \begin{cases} 2x - 3y = 8 \\ 8x + 5y = -2 \end{cases} \qquad 49. \begin{cases} 5x + 7y = 9 \\ 2x + 3y = -7 \end{cases} \qquad 50. \begin{cases} 5x - 10y = 9 \\ -x + 2y = -3 \end{cases}$$

$$51. \begin{cases} -2x - 2y = 4 \\ 3x + 3y = -6 \end{cases} \qquad 52. \begin{cases} \frac{2}{3}x + y = -3 \\ 3x + \frac{5}{2}y = -\frac{7}{2} \end{cases} \qquad 53. \begin{cases} \frac{2}{3}x + 2y = 1 \\ x + 3y = 0 \end{cases}$$

$$54. \begin{cases} x + 2y = -1 \\ y + 3z = 7 \\ 2x + 5z = 21 \end{cases}$$

$$55. \begin{cases} 2x - y = 0 \\ 5x - 3y - 3z = 5 \\ 2x + 6z = -10 \end{cases}$$

$$56. \begin{cases} 3x + 8z = 3 \\ -3x - 7z = -3 \\ x + 3z = 1 \end{cases}$$

$$57. \begin{cases} 3w - x + 5y + 3z = 2 \\ -4w - 10y - 2z = 10 \\ w - x + 2z = 7 \\ 4w - 2x + 5y + 5z = 9 \end{cases}$$

$$58. \begin{cases} 2w + x - 3y = 3 \\ w - 2x + y = 1 \\ x + z = -2 \\ y + z = 0 \end{cases}$$

$$59. \begin{cases} 3w - 2x + y - 5z = -1 \\ w + x - y + 4z = 2 \\ 4w - x - z = 1 \\ 5w - x = 9 \end{cases}$$

$$60. \begin{cases} -4x + y = 1 \\ 7x + 2y = 407 \end{cases}$$

$$61. \begin{cases} 5x - 4y = -49 \\ 24x - 19y = 179 \end{cases}$$

$$62. \begin{cases} 2w - 3x + 4y - z = 21 \\ w + 5x = 2 \\ -2x + 3y + z = 12 \\ -3w + 4z = -5 \end{cases}$$

$$63. \begin{cases} -5x + 10y = 3 \\ \frac{7}{2}x - 7y = 20 \end{cases}$$

$$64. \begin{cases} 23x + 21y = -4 \\ x - 3y = -8 \end{cases}$$

$$65. \begin{cases} w - x + y - z = 2 \\ 2w - x + 3y = -5 \\ x - 2z = 7 \\ 3w + 4x = -13 \end{cases}$$

### APPLICATIONS

66. The three sides of a triangle are related as follows: the perimeter is 43 feet, the second side is 5 feet more than twice the first side, and the third side is 3 feet less than the sum of the other two sides. Find the lengths of the three sides of the triangle.
67. Eric's favorite candy bar and ice cream flavor have fat and calorie contents as follows: each candy bar has 5 grams of fat and 280 calories; each serving of ice cream has 10 grams of fat and 150 calories. How many candy bars and servings of ice cream did he eat during the weekend he consumed 85 grams of fat and 2300 calories from these two treats?
68. A farmer plants soybeans, corn, and wheat and rotates the planting each year on her 500-acre farm. In a particular year, the profits from her crops were \$120 per acre of soybeans, \$100 per acre of corn, and \$80 per acre of wheat. She planted twice as many acres of corn as soybeans. How many acres did she plant with each crop that year if she made a total profit of \$51,800?

 TECHNOLOGY

Using a graphing utility find the determinant of the matrix.

$$69. \begin{vmatrix} 0.1 & 0.4 & -0.7 \\ 0.3 & -0.1 & 0.2 \\ 0.5 & -0.2 & 0.3 \end{vmatrix}$$

$$70. \begin{vmatrix} 0.1 & 0.3 & 0.1 \\ 0.2 & -0.2 & -0.1 \\ -0.1 & -0.4 & 0.5 \end{vmatrix}$$

$$71. \begin{vmatrix} 2.2 & 0.3 & -1.7 \\ 0.4 & -0.2 & 0.1 \\ 0.2 & 0.3 & -1.6 \end{vmatrix}$$

$$72. \begin{vmatrix} 3.1 & 0.6 & -1.1 \\ 1.2 & 5.2 & -7.3 \\ -0.1 & -4.1 & 6.5 \end{vmatrix}$$

$$73. \begin{vmatrix} 13 & 23 & -21 \\ 17 & -32 & 14 \\ 15 & 12 & -16 \end{vmatrix}$$

$$74. \begin{vmatrix} 25 & 32 & 17 \\ -13 & 14 & -24 \\ 16 & 26 & 36 \end{vmatrix}$$

Use a graphing utility and Cramer's Rule to solve each system of equations.

$$75. \begin{cases} x - 2y + 3z = 9 \\ -x + 3y = -4 \\ 2x - 5y + 5z = 17 \end{cases}$$

$$76. \begin{cases} 2x + 4y + z = 1 \\ x - 2y - 3z = 2 \\ x + y - z = -1 \end{cases}$$

$$77. \begin{cases} w + x + y + z = 6 \\ -w + 2x + 3y = 0 \\ 2w - 3x + 4y + z = 4 \\ w + x + 2y - z = 0 \end{cases}$$

for large  $n$  (the value for  $n$  at which this happens will vary depending on the technology used). This means that, after a few months, store  $A$  can count on roughly 60% of the town's customers and store  $B$  can count on roughly 40% (the actual identities of the customers will keep changing from month to month, but the relative proportions will have stabilized). We can verify that the situation is stable by applying the transition matrix to an assumed 1000 customers split 60:40.

$$\begin{bmatrix} 0.7 & 0.45 \\ 0.3 & 0.55 \end{bmatrix} \begin{bmatrix} 600 \\ 400 \end{bmatrix} = \begin{bmatrix} 600 \\ 400 \end{bmatrix}$$

You will see another approach to determining the stable long-term state in the exercises.

## 11.4 EXERCISES

### PRACTICE

Given  $A = \begin{bmatrix} 3 & -2 \\ 1 & 0 \\ 0 & 5 \end{bmatrix}$ ,  $B = \begin{bmatrix} 4 & -5 \\ 3 & 0 \\ -2 & 2 \end{bmatrix}$ ,  $C = \begin{bmatrix} 2 & -1 \\ 6 & 10 \\ -3 & 7 \end{bmatrix}$ , and  $D = \begin{bmatrix} 3 & 2 & 5 \\ -2 & -4 & 1 \end{bmatrix}$ ,

determine the following, if possible. See Examples 1, 3, and 4.

- |             |                |               |                                  |
|-------------|----------------|---------------|----------------------------------|
| 1. $3A - B$ | 2. $B - 2D$    | 3. $3C$       | 4. $\frac{1}{2}D$                |
| 5. $3D + C$ | 6. $A + B + C$ | 7. $2A + 2B$  | 8. $\frac{3}{2}B + \frac{1}{2}C$ |
| 9. $C - 3A$ | 10. $3C - A$   | 11. $4A - 3D$ | 12. $2(A - 3B)$                  |

Determine values of the variables that will make the following equations true, if possible. See Examples 1–4.

$$13. \begin{bmatrix} 2a & b & 3 \\ -5 & 9 & 7 \end{bmatrix} = \begin{bmatrix} 6 & -1 & 3 \\ -5 & 9 & c-3 \end{bmatrix}$$

$$14. \begin{bmatrix} x \\ -9 \\ -1+z \end{bmatrix} = \begin{bmatrix} 8 \\ 3y \\ 5 \end{bmatrix}$$

$$15. [a \ 2b \ c] + 3[a \ 2 \ -c] = [8 \ 2 \ 2]$$

$$16. \begin{bmatrix} w & 5x \\ 2y & z \end{bmatrix} - 5 \begin{bmatrix} w & x \\ y & -z \end{bmatrix} = \begin{bmatrix} w+5 & 0 \\ 6 & 1 \end{bmatrix}$$

$$17. \begin{bmatrix} 3x \\ 2y \end{bmatrix} + \begin{bmatrix} x \\ -y \\ z \end{bmatrix} = \begin{bmatrix} 4 \\ 0 \\ 2 \end{bmatrix}$$

$$18. [2a \ 3b \ c] = \begin{bmatrix} 4 \\ 3 \\ 0 \end{bmatrix}$$

19. 
$$\begin{bmatrix} x \\ 3x \end{bmatrix} - \begin{bmatrix} y \\ 2y \end{bmatrix} = \begin{bmatrix} 5 \\ 20 \end{bmatrix}$$

20. 
$$7 \begin{bmatrix} -1 \\ y \end{bmatrix} = \begin{bmatrix} 2x \\ 5x \end{bmatrix} + 3 \begin{bmatrix} y \\ 1 \end{bmatrix}$$

21. 
$$2 \begin{bmatrix} x \\ 2y \end{bmatrix} - 3 \begin{bmatrix} 5y \\ -3x \end{bmatrix} = \begin{bmatrix} -9 \\ 31 \end{bmatrix}$$

22. 
$$2[3r \ s \ 2t] - [r \ s \ t] = [15 \ 3 \ 9]$$

23. 
$$2 \begin{bmatrix} 2x^2 & x \\ 7x & 4 \end{bmatrix} - \begin{bmatrix} 5x \\ x-2 \end{bmatrix} = \begin{bmatrix} 2x & 0 \\ 6 & x^2 \end{bmatrix}$$

24. 
$$\begin{bmatrix} -x \\ 3 \end{bmatrix} - 5 \begin{bmatrix} 2 \\ y \end{bmatrix} = \begin{bmatrix} -2y \\ 3x \end{bmatrix}$$

25. 
$$3 \begin{bmatrix} 2a \\ -a \end{bmatrix} - 3 \begin{bmatrix} 3b \\ 2b \end{bmatrix} = \begin{bmatrix} 3 \\ -54 \end{bmatrix}$$

26. 
$$2 \begin{bmatrix} -s \\ -7 \end{bmatrix} + 2 \begin{bmatrix} -2r \\ r \end{bmatrix} = -2 \begin{bmatrix} 8 \\ s \end{bmatrix}$$

Evaluate the following matrix products, if possible. See Examples 5 and 6.

27. 
$$\begin{bmatrix} 3 & -2 & 1 \end{bmatrix} \begin{bmatrix} 5 & -1 \\ 0 & 3 \\ 9 & 4 \end{bmatrix}$$

28. 
$$\begin{bmatrix} 0 & -8 \\ 5 & 6 \end{bmatrix} \begin{bmatrix} 3 & 7 \end{bmatrix}$$

29. 
$$\begin{bmatrix} 3 & 7 \end{bmatrix} \begin{bmatrix} 0 & -8 \\ 5 & 6 \end{bmatrix}$$

30. 
$$\begin{bmatrix} 5 & 0 & -3 \end{bmatrix} \begin{bmatrix} 4 \\ 2 \\ -6 \end{bmatrix}$$

31. 
$$\begin{bmatrix} 3 & 9 & -4 \\ 0 & 0 & 2 \\ 5 & -2 & 7 \end{bmatrix} \begin{bmatrix} 3 & 2 \\ 2 & 1 \end{bmatrix}$$

32. 
$$\begin{bmatrix} 4 \\ 2 \\ -6 \end{bmatrix} \begin{bmatrix} 5 & 0 & -3 \end{bmatrix}$$

33. 
$$\begin{bmatrix} -3 & -6 & -3 \end{bmatrix} \begin{bmatrix} 6 & 9 \\ 6 & -8 \\ -8 & 8 \end{bmatrix}$$

34. 
$$\begin{bmatrix} 4 & -5 \\ 7 & -9 \end{bmatrix} \begin{bmatrix} -8 & 3 \end{bmatrix}$$

35. 
$$\begin{bmatrix} -3 \\ -5 \\ -6 \end{bmatrix} \begin{bmatrix} -5 & 1 & 8 \end{bmatrix}$$

Given  $A = \begin{bmatrix} -3 & 1 \\ 2 & 3 \end{bmatrix}$ ,  $B = [8 \ -5]$ ,  $C = \begin{bmatrix} 4 \\ 7 \\ -2 \end{bmatrix}$ , and  $D = \begin{bmatrix} -5 & 4 \\ -1 & -1 \end{bmatrix}$ , determine the

following, if possible. See Examples 5 and 6.

36.  $AB$

37.  $BA$

38.  $BA + B$

39.  $A^2$

40.  $C^2$

41.  $CB$

42.  $D^2$

43.  $CD + C$

44.  $DA$

45.  $AD$

46.  $DB$

47.  $(BD)A$

 APPLICATIONS

48. Suppose that each month 20% of store B's customers switch to store A, and 10% of store A's customers switch back to store B. At the start of January, store A has 300 customers and store B has 700. How many customers can each store expect at the start of February? At the start of March?
49. Given the percentages stated in the last problem, what long-term proportion of the town's customers can each store expect? (A graphing utility may be used to compute high powers of the transition matrix, or you can use the method described in the following exercise.)

 WRITING & THINKING

50. Suppose  $P$  is a  $2 \times 2$  transition matrix, and we want to determine the effect of applying high powers of  $P$  to the matrix

$$\begin{bmatrix} x \\ y \end{bmatrix},$$

where  $x + y$  is a fixed constant, say  $c$ . (In our competing store situation,  $x + y = 1000$ .) If the long-term behavior approaches a steady state, as in our two-store example, then there is some value for  $x$  and some value for  $y$  such that  $x + y = c$  and

$$P \begin{bmatrix} x \\ y \end{bmatrix} = \begin{bmatrix} x \\ y \end{bmatrix}.$$

In other words, once the steady state has been reached, applying the matrix  $P$  to it has no effect on the state.

We can use this fact to actually solve for  $x$  and  $y$  as follows. Given the matrix

$$P = \begin{bmatrix} 0.7 & 0.45 \\ 0.3 & 0.55 \end{bmatrix},$$

write the equation

$$P \begin{bmatrix} x \\ y \end{bmatrix} = \begin{bmatrix} x \\ y \end{bmatrix}$$

in system form. You should find that the two equations that result are actually identical. But if we now also use the fact that  $x + y = 1000$ , we can solve for the variables and find that  $x = 600$  and  $y = 400$ . Verify that this is indeed the case.

51. Your friend Jared is having trouble with matrices, so you offer to study with him. Check his solution of the following problem. If the solution is incorrect, explain the error that has been made.

$$\begin{aligned}
 & 2 \begin{bmatrix} -8 & -9 & -1 \\ -8 & 1 & 5 \end{bmatrix} - 2 \begin{bmatrix} -2 & 3 \\ 5 & -7 \\ -8 & -1 \end{bmatrix} \\
 &= \begin{bmatrix} -16 & -18 & -2 \\ -16 & 2 & 10 \end{bmatrix} + \begin{bmatrix} 4 & -6 \\ -10 & 14 \\ 16 & 2 \end{bmatrix} \\
 &= \begin{bmatrix} -16+4-18-10-2+16 & -16-6-18+14-2+2 \\ -16+4+2-10+10+2 & -16-6+2+14+10+2 \end{bmatrix} \\
 &= \begin{bmatrix} -26 & -26 \\ -8 & 6 \end{bmatrix}
 \end{aligned}$$

 TECHNOLOGY

Given  $A = \begin{bmatrix} 3.8 & -1.2 & 4.6 \end{bmatrix}$ ,  $B = \begin{bmatrix} -8.2 & -4.9 \\ 7.4 & -1.3 \\ 3.5 & -2.1 \end{bmatrix}$ ,  $C = \begin{bmatrix} 6.3 \\ 5.7 \end{bmatrix}$ , and  $D = \begin{bmatrix} 2.8 & -7.1 \\ -5.4 & 6.6 \end{bmatrix}$ ,

use a graphing utility to determine the following, if possible.

52.  $BD$

53.  $CA$

54.  $D^2$

55.  $AB$

56.  $DC$

57.  $BC$

$$\begin{bmatrix} x \\ y \\ z \end{bmatrix} = \begin{bmatrix} -1 & -1 & -1 \\ -2 & -1 & -2 \\ -6 & -3 & -7 \end{bmatrix} \begin{bmatrix} -17 \\ 2 \\ 14 \end{bmatrix} = \begin{bmatrix} 1 \\ 4 \\ -2 \end{bmatrix}$$

$$\begin{bmatrix} x \\ y \\ z \end{bmatrix} = \begin{bmatrix} -1 & -1 & -1 \\ -2 & -1 & -2 \\ -6 & -3 & -7 \end{bmatrix} \begin{bmatrix} 3 \\ 5 \\ -5 \end{bmatrix} = \begin{bmatrix} -3 \\ -1 \\ 2 \end{bmatrix}$$

### TECHNOLOGY: Inverting Matrices

We can also use a graphing utility to find the inverse of a matrix. When using a TI-84 Plus, first define the matrix whose inverse we want to find. Then, enter the matrix on the home screen, press  $x^{-1}$ , and press **enter**.

To show the answer in fraction form, press **math** and select  $\blacktriangleright$ Frac. If we defined matrix  $A$  to be  $\begin{bmatrix} 7 & 4 \\ 1 & 2 \end{bmatrix}$ , we would find its inverse as shown in Figure 1.

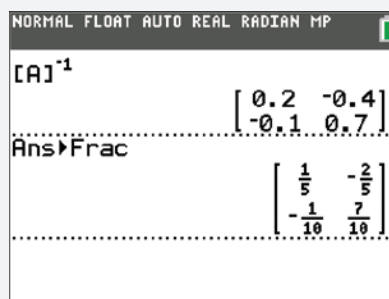

FIGURE 1

## 11.5 EXERCISES

### PRACTICE

Write each of the following systems of equations as a single matrix equation. See Example 1.

- $$\begin{cases} 14x - 5y = 7 \\ x + 9y = 2 \end{cases}$$
- $$\begin{cases} x - 5 = 9y \\ 3y - 2x = 8 \end{cases}$$
- $$\begin{cases} -6 - 2y = x \\ 9x + 14 = 3y \end{cases}$$
- $$\begin{cases} x - y = 5 \\ 2 - z = x \\ z - 3y = 4 \end{cases}$$
- $$\begin{cases} 3x_1 - 7x_2 + x_3 = -4 \\ x_1 - x_2 = 2 \\ 8x_2 + 5x_3 = -3 \end{cases}$$
- $$\begin{cases} x_3 = x_2 \\ x_2 = x_1 \\ x_1 = x_3 \end{cases}$$
- $$\begin{cases} \frac{3x - 8y}{5} = 2 \\ y - 2 = 0 \end{cases}$$
- $$\begin{cases} x - 7y = 5 \\ \frac{6 + x}{2} = 3y - 2 \end{cases}$$
- $$\begin{cases} 4x = 3y - 9 \\ 13 - 2x = -4y \end{cases}$$

$$10. \begin{cases} -\frac{7}{3}y = \frac{5-x}{6} \\ x-5(y-3) = -2 \end{cases} \quad 11. \begin{cases} 2x-y = -3z \\ y-x = 17 \\ 2+z+4x = 5y \end{cases} \quad 12. \begin{cases} 2x_1 - 3x_3 = 7 \\ x_2 - 10x_3 = 0 \\ 2x_1 - x_2 + x_3 = 1 \end{cases}$$

Find the inverse of each of the following matrices, if possible. See Examples 2 and 3.

$$13. \begin{bmatrix} 0 & 4 \\ -5 & -1 \end{bmatrix} \quad 14. \begin{bmatrix} -2 & -2 \\ -1 & 2 \end{bmatrix} \quad 15. \begin{bmatrix} 3 & 4 \\ -4 & -5 \end{bmatrix}$$

$$16. \begin{bmatrix} -1 & -1 \\ -\frac{1}{4} & -\frac{1}{2} \end{bmatrix} \quad 17. \begin{bmatrix} -\frac{1}{5} & 0 \\ \frac{1}{5} & \frac{1}{2} \end{bmatrix} \quad 18. \begin{bmatrix} -7 & 2 \\ 7 & -2 \end{bmatrix}$$

$$19. \begin{bmatrix} -2 & -4 & -2 \\ 1 & -4 & 1 \\ 4 & -3 & 4 \end{bmatrix} \quad 20. \begin{bmatrix} -3 & 0 & -4 \\ 2 & 5 & 4 \\ 1 & -5 & -2 \end{bmatrix} \quad 21. \begin{bmatrix} -\frac{5}{11} & -\frac{8}{11} & 1 \\ \frac{13}{11} & \frac{12}{11} & -2 \\ -\frac{2}{11} & -\frac{1}{11} & 0 \end{bmatrix}$$

$$22. -\frac{1}{31} \begin{bmatrix} 17 & -8 & -2 \\ 1 & 5 & 9 \\ -6 & 1 & 8 \end{bmatrix} \quad 23. \begin{bmatrix} -1 & 2 & -1 \\ 0 & 3 & -1 \\ 0 & 4 & -1 \end{bmatrix} \quad 24. \begin{bmatrix} -1 & 0 & -1 \\ -\frac{3}{2} & \frac{1}{2} & -\frac{3}{2} \\ -\frac{1}{2} & 0 & -\frac{1}{4} \end{bmatrix}$$

$$25. \begin{bmatrix} -\frac{6}{5} & -\frac{2}{5} & -1 \\ \frac{3}{5} & \frac{1}{5} & 1 \\ 1 & 0 & 1 \end{bmatrix} \quad 26. \begin{bmatrix} 2 & -2 & 1 \\ -2 & 2 & -3 \\ 1 & 0 & 2 \end{bmatrix} \quad 27. \begin{bmatrix} 0 & 1 & 1 \\ 1 & 1 & 0 \\ 0 & 1 & 2 \end{bmatrix}$$

$$28. \begin{bmatrix} 9 & 8 & 7 \\ 6 & 5 & 4 \\ 3 & 2 & 1 \end{bmatrix} \quad 29. \begin{bmatrix} \frac{2}{3} & \frac{8}{9} & \frac{1}{9} \\ -\frac{1}{3} & \frac{2}{9} & -\frac{2}{9} \\ -\frac{1}{3} & -\frac{7}{9} & -\frac{2}{9} \end{bmatrix} \quad 30. \begin{bmatrix} -3 & -3 & -4 \\ 0 & \frac{1}{4} & \frac{1}{2} \\ 2 & 2 & 3 \end{bmatrix}$$

For each pair of matrices, determine if either matrix is the inverse of the other.

$$31. \begin{bmatrix} -5 & -2 \\ -7 & 4 \end{bmatrix}, \begin{bmatrix} 10 & 4 \\ 14 & -8 \end{bmatrix} \quad 32. \begin{bmatrix} 9 & -18 \\ 3 & 12 \end{bmatrix}, \begin{bmatrix} -3 & -6 \\ -1 & -4 \end{bmatrix}$$

$$33. \begin{bmatrix} -6 & -1 & 1 \\ 4 & -1 & -2 \\ 1 & -1 & -1 \end{bmatrix}, \begin{bmatrix} -1 & -2 & 3 \\ 2 & 5 & -8 \\ -3 & -7 & 10 \end{bmatrix} \quad 34. \begin{bmatrix} -1 & 4 & 5 \\ 3 & -11 & -17 \\ 4 & -17 & -19 \end{bmatrix}, \begin{bmatrix} -80 & -9 & -13 \\ -11 & -1 & -2 \\ -7 & -1 & -1 \end{bmatrix}$$

$$35. \begin{bmatrix} 2 & 0 & -1 \\ 3 & 4 & 2 \\ 1 & 1 & -3 \end{bmatrix}, \begin{bmatrix} 4 & 0 & -2 \\ 6 & 8 & 4 \\ 2 & 2 & -6 \end{bmatrix} \quad 36. \begin{bmatrix} -7 & 0 & -2 \\ -10 & -1 & -2 \\ -7 & -1 & -1 \end{bmatrix}, \begin{bmatrix} -1 & 2 & -2 \\ 4 & -7 & 6 \\ 3 & -7 & 7 \end{bmatrix}$$

Solve the following systems by the inverse matrix method, if possible. If the inverse matrix method doesn't apply, use any other method to determine if the system is inconsistent or dependent. See Example 4.

$$37. \begin{cases} -2x - 2y = 9 \\ -x + 2y = -3 \end{cases} \quad 38. \begin{cases} 3x + 4y = -2 \\ -4x - 5y = 9 \end{cases} \quad 39. \begin{cases} -2x + 3y = 1 \\ 4x - 6y = -2 \end{cases}$$

$$40. \begin{cases} -2x + 4y = 5 \\ x - 4y = -3 \end{cases} \quad 41. \begin{cases} -5x = 10 \\ 2x + 2y = -4 \end{cases} \quad 42. \begin{cases} -3x + y = 2 \\ 9x - 3y = 5 \end{cases}$$

$$43. \begin{cases} 8x + 2y = 26 \\ -16x - 2y = -90 \end{cases} \quad 44. \begin{cases} 3x - 7y = -2 \\ -6x + 14y = 4 \end{cases} \quad 45. \begin{cases} 3y = 15 \\ 8x + 4y = 20 \end{cases}$$

$$46. \begin{cases} 4y + 3z = -254 \\ 2x - 2y - z = 100 \\ -x + y - 2z = 155 \end{cases} \quad 47. \begin{cases} 2x - y - 3z = -10 \\ 2y - z = 11 \\ -x + 4z = 0 \end{cases} \quad 48. \begin{cases} 3y - 4z = 15 \\ x + 2y - 3z = 9 \\ -x - y + 2z = -5 \end{cases}$$

Solve the following sets of systems by the inverse matrix method. See Example 5.

$$49. \begin{cases} x + 2y - z = 2 \\ 3x + 3y - z = -5 \\ 4x + 4y - z = 1 \end{cases} \quad \begin{cases} x + 2y - z = 1 \\ 3x + 3y - z = 1 \\ 4x + 4y - z = 1 \end{cases} \quad \begin{cases} x + 2y - z = 0 \\ 3x + 3y - z = 1 \\ 4x + 4y - z = 1 \end{cases}$$

$$50. \begin{cases} -x - y - 2z = 4 \\ x + 3y + 3z = 0 \\ -3y - 2z = 9 \end{cases} \quad \begin{cases} -x - y - 2z = 1 \\ x + 3y + 3z = 0 \\ -3y - 2z = 0 \end{cases} \quad \begin{cases} -x - y - 2z = -2 \\ x + 3y + 3z = -3 \\ -3y - 2z = 1 \end{cases}$$

$$51. \begin{cases} -x + z = 6 \\ -x + 3y + 2z = -11 \\ 2x - 4y - 3z = 13 \end{cases} \quad \begin{cases} -x + z = -2 \\ -x + 3y + 2z = 2 \\ 2x - 4y - 3z = -1 \end{cases} \quad \begin{cases} -x + z = -4 \\ -x + 3y + 2z = 2 \\ 2x - 4y - 3z = 0 \end{cases}$$

### TECHNOLOGY

Using a graphing utility, find the inverse of each of the following matrices, if possible. Round your answers to three decimal places if necessary.

$$52. \begin{bmatrix} -7 & 3 \\ -1 & 2 \end{bmatrix} \quad 53. \begin{bmatrix} -6 & 2 \\ -5 & 5 \end{bmatrix} \quad 54. \begin{bmatrix} -2 & 0 & 2 \\ 2 & -3 & 1 \\ 1 & -2 & 3 \end{bmatrix}$$

$$55. \begin{bmatrix} 2.3 & 7.8 \\ -3.4 & 1.6 \end{bmatrix} \quad 56. \begin{bmatrix} 4.5 & -9.4 & 6.9 \\ 8.6 & -2.8 & 1.2 \\ 3.1 & 0.3 & -7.0 \end{bmatrix} \quad 57. \begin{bmatrix} 38 & -44 & 72 \\ -93 & 16 & 29 \\ 65 & 23 & -19 \end{bmatrix}$$

Polynomial long division (Section 5.2) then gives us the following result.

$$\frac{3x^5 + 6x^4 + 9x^3 + 7x^2 + 4x - 1}{(x^2 + x + 1)^2} = 3x + \frac{x^2 + x - 1}{(x^2 + x + 1)^2}$$

Now we need to decompose the fractional part.

Note that  $x^2 + x + 1$  is irreducible. This follows from the use of the quadratic formula to solve the equation  $x^2 + x + 1 = 0$ ; since the solutions of this equation are complex numbers, the linear factors of  $x^2 + x + 1$  contain complex coefficients. The partial fraction decomposition thus has the following form.

$$\frac{x^2 + x - 1}{(x^2 + x + 1)^2} = \frac{A_1x + B_1}{x^2 + x + 1} + \frac{A_2x + B_2}{(x^2 + x + 1)^2}$$

Clearing the equation of fractions gives us the following.

$$\begin{aligned} x^2 + x - 1 &= (A_1x + B_1)(x^2 + x + 1) + (A_2x + B_2) \\ x^2 + x - 1 &= A_1x^3 + (A_1 + B_1)x^2 + (A_1 + B_1 + A_2)x + (B_1 + B_2) \end{aligned}$$

From this polynomial equation we derive the following system.

$$\begin{cases} 0 = A_1 \\ 1 = A_1 + B_1 \\ 1 = A_1 + B_1 + A_2 \\ -1 = B_1 + B_2 \end{cases}$$

This system is easily solved, considering the equations in the order presented, and gives us  $A_1 = 0$ ,  $B_1 = 1$ ,  $A_2 = 0$ , and  $B_2 = -2$ . The following answer results.

$$\frac{3x^5 + 6x^4 + 9x^3 + 7x^2 + 4x - 1}{(x^2 + x + 1)^2} = 3x + \frac{1}{x^2 + x + 1} + \frac{-2}{(x^2 + x + 1)^2}$$

## 11.6 EXERCISES

### PRACTICE

Write the form of the partial fraction decomposition of each of the following rational functions. In each case, assume the degree of the numerator is less than the degree of the denominator. See Examples 1 and 2.

1.  $f(x) = \frac{p(x)}{x^2 - x - 6}$

2.  $f(x) = \frac{p(x)}{x^2 - 2x - 24}$

3.  $f(x) = \frac{p(x)}{x^3 + 11x^2 + 40x + 48}$

4.  $f(x) = \frac{p(x)}{(x+5)^2(x^2+3)^2}$

5.  $f(x) = \frac{p(x)}{(x+3)(x^2-4)}$

6.  $f(x) = \frac{p(x)}{(x^2+5)(x^2+3x-4)}$

Match each rational expression with the form of its decomposition. The decompositions are labeled a.–h.

7.  $\frac{2x-1}{(x+2)^3(x-2)}$

8.  $\frac{2x-1}{x^2(x^2-4)}$

9.  $\frac{2x-1}{x^3-4x^2+4x}$

10.  $\frac{2x-1}{x^4-16}$

11.  $\frac{2x-1}{x^3(x-2)^2}$

12.  $\frac{2x-1}{x^5+2x^4+4x^3+8x^2}$

13.  $\frac{2x-1}{x^3(x-2)}$

14.  $\frac{2x-1}{x^5+6x^4+12x^3+8x^2}$

a.  $\frac{A}{x} + \frac{B}{x^2} + \frac{C}{x^3} + \frac{D}{x-2} + \frac{E}{(x-2)^2}$

b.  $\frac{A}{x} + \frac{B}{x^2} + \frac{C}{x+2} + \frac{D}{x-2}$

c.  $\frac{A}{x} + \frac{B}{x^2} + \frac{C}{x^3} + \frac{D}{x-2}$

d.  $\frac{A}{x+2} + \frac{B}{(x+2)^2} + \frac{C}{(x+2)^3} + \frac{D}{x-2}$

e.  $\frac{Ax+B}{x^2+4} + \frac{C}{x+2} + \frac{D}{x-2}$

f.  $\frac{A}{x} + \frac{B}{x^2} + \frac{C}{x+2} + \frac{Dx+E}{x^2+4}$

g.  $\frac{A}{x+2} + \frac{B}{(x+2)^2} + \frac{C}{(x+2)^3} + \frac{D}{x} + \frac{E}{x^2}$

h.  $\frac{A}{x} + \frac{B}{x-2} + \frac{C}{(x-2)^2}$

Find the partial fraction decomposition of each of the following rational functions. See Examples 3, 4, and 5.

15.  $f(x) = \frac{3x^2+4}{x^3-4x}$

16.  $f(x) = \frac{2x}{x^3+7x^2-6x-72}$

17.  $f(x) = \frac{4x+2}{(x^3+8x)(x^2+2x-8)}$

18.  $f(x) = \frac{5}{x^2+3x-4}$

19.  $f(x) = \frac{5x}{x^2-6x+8}$

20.  $f(x) = \frac{6x^2-4}{(x^2+3)(x+6)(x+5)}$

21.  $f(x) = \frac{6x}{x^3+8x^2+9x-18}$

22.  $f(x) = \frac{12x^2+x-1}{x^4+7x^3+5x^2-31x-30}$

23.  $f(x) = \frac{1}{x^2-1}$

24.  $f(x) = \frac{x+3}{(x^2+3)(x^2+x-6)}$

25.  $f(x) = \frac{x^2-4}{(x^4-16)(x^2+2x-8)}$

26.  $f(x) = \frac{x+1}{x^3-x}$

27.  $f(x) = \frac{x+3}{x^2-4}$

28.  $f(x) = \frac{x}{x^3+6x^2+11x+6}$

29.  $f(x) = \frac{x}{x^4 - 16}$

30.  $f(x) = \frac{5}{x^2 - 6x + 8}$

31.  $f(x) = \frac{2x + 3}{(x^2 - 9)(x^2 + 4x - 12)}$

32.  $f(x) = \frac{x}{x^2 - 7x + 12}$

33.  $f(x) = \frac{x^2}{x^3 + 5x^2 + 3x - 9}$

34.  $f(x) = \frac{2x}{(x + 4)(x^2 - 2x - 3)}$

35.  $f(x) = \frac{2x}{x^2 - 9}$

36.  $f(x) = \frac{4x + 3}{(x^2 - 9)(x^2 - 2x - 24)}$

37.  $f(x) = \frac{x^2}{x^3 + 4x^2 - 12x}$

38.  $f(x) = \frac{2}{x^3 + 7x^2 - 8x}$

Write the partial fraction decomposition for the rational expression. You may check your answer by assigning a value to the constant  $a$  and graphing the result.

39.  $\frac{1}{x(x + a)}$

40.  $\frac{1}{x(a - x)}$

41.  $\frac{1}{a^2 - x^2}$

42.  $\frac{1}{(x + 1)(a - x)}$

43.  $\frac{1}{(x + a)(x + 1)}$

### TECHNOLOGY

Using a graphing utility, determine whether the partial fraction decomposition is true or false by graphing the left and right side of the equation on the same coordinate plane.

44.  $\frac{x + 7}{x^2 - x - 6} = \frac{2}{x - 3} - \frac{1}{x + 2}$

45.  $\frac{5x^2 + 20x + 6}{x^3 + 2x^2 + x} = \frac{6}{x} - \frac{1}{x + 1} + \frac{9}{(x + 1)^2}$

46.  $\frac{4x^2 - 3x - 4}{x^3 + x^2 - 2x} = \frac{2}{x} - \frac{1}{x - 1} + \frac{3}{x + 2}$

47.  $\frac{2x + 4}{x^3 - 2x^2} = -\frac{2}{x} - \frac{2}{x^2} + \frac{2}{x - 2}$

48.  $\frac{1}{x^2 + x - 2} = \frac{1}{x - 1} + \frac{1}{x + 2}$

49.  $\frac{6x^2 + 2}{x^2(x - 3)^3} = \frac{4}{x} + \frac{2}{x^2} + \frac{3x}{x - 3} + \frac{4}{(x - 3)^2} + \frac{6x}{(x - 3)^3}$

## 11.7 EXERCISES

### PRACTICE

Graph the solution set of each of the following systems of inequalities. See Example 1.

$$1. \begin{cases} y \geq -2 \\ y > 1 \end{cases}$$

$$2. \begin{cases} y \geq -2x - 5 \\ y \leq -6x - 9 \end{cases}$$

$$3. \begin{cases} y \leq 4x + 4 \\ y > 7x + 7 \end{cases}$$

$$4. \begin{cases} x - 3y \geq 6 \\ y > -4 \end{cases}$$

$$5. \begin{cases} 3x - y \leq 2 \\ x + y > 0 \end{cases}$$

$$6. \begin{cases} x > 1 \\ y > 2 \end{cases}$$

$$7. \begin{cases} x + y > -2 \\ x + y < -4 \end{cases}$$

$$8. \begin{cases} y > -2 \\ 2y > -3x - 4 \end{cases}$$

$$9. \begin{cases} y \leq -x \\ 2y + 3x > -4 \end{cases}$$

$$10. \begin{cases} 5x + 6y < -30 \\ x \geq 2 \end{cases}$$

$$11. \begin{cases} x < 6 \\ x \geq -5 \end{cases}$$

$$12. \begin{cases} |x + 1| < 2 \\ |y - 3| \leq 1 \end{cases}$$

$$13. \begin{cases} |y - 3x| \leq 2 \\ |y| < 2 \end{cases}$$

Find the minimum and maximum values of the given functions, subject to the given constraints. See Examples 3 and 4.

14. Objective Function:

$$f(x, y) = 2x + 3y$$

Constraints:

$$\begin{cases} x \geq 0, y \geq 0 \\ x + y \leq 7 \end{cases}$$

15. Objective Function:

$$f(x, y) = 4x + y$$

Constraints:

$$\begin{cases} x \geq 0, y \geq 0 \\ x + y \leq 3 \end{cases}$$

16. Objective Function:

$$f(x, y) = 2x + 5y$$

Constraints:

$$\begin{cases} x \geq 0, y \geq 0 \\ x + y \leq 7 \end{cases}$$

17. Objective Function:

$$f(x, y) = 7x + 4y$$

Constraints:

$$\begin{cases} x \geq 0, y \geq 0 \\ 3x + y \leq 3 \end{cases}$$

18. Objective Function:

$$f(x, y) = 5x + 6y$$

Constraints:

$$\begin{cases} 0 \leq x \leq 7 \\ 0 \leq y \leq 10 \\ 8x + 5y \geq 40 \end{cases}$$

19. Objective Function:

$$f(x, y) = 9x + 7y$$

Constraints:

$$\begin{cases} 0 \leq x \leq 20 \\ 0 \leq y \leq 10 \\ 6x + 12y \geq 140 \end{cases}$$

20. Objective Function:

$$f(x, y) = 6x + 4y$$

Constraints:

$$\begin{cases} 0 \leq x \leq 4 \\ 0 \leq y \leq 5 \\ 4x + 3y \geq 10 \end{cases}$$

22. Objective Function:

$$f(x, y) = 6x + 8y$$

Constraints:

$$\begin{cases} x \geq 0, y \geq 0 \\ 4x + y \leq 16 \\ x + 3y \leq 15 \end{cases}$$

24. Objective Function:

$$f(x, y) = 6x + y$$

Constraints:

$$\begin{cases} x \geq 0, y \geq 0 \\ 3x + 4y \geq 24 \\ 3x + 4y \leq 48 \end{cases}$$

26. Objective Function:

$$f(x, y) = 3x + 10y$$

Constraints:

$$\begin{cases} x \geq 0 \\ 2x + 4y \geq 8 \\ 5x - y \leq 10 \\ x + 3y \leq 40 \end{cases}$$

21. Objective Function:

$$f(x, y) = 3x + 7y$$

Constraints:

$$\begin{cases} 0 \leq x \leq 8 \\ 0 \leq y \leq 6 \\ 7x + 10y \geq 50 \end{cases}$$

23. Objective Function:

$$f(x, y) = x + 2y$$

Constraints:

$$\begin{cases} x \geq 0, y \geq 0 \\ 3x + y \leq 45 \\ x + 3y \leq 24 \end{cases}$$

25. Objective Function:

$$f(x, y) = 15x + 30y$$

Constraints:

$$\begin{cases} x \geq 0, y \geq 0 \\ 5x + 7y \geq 70 \\ 5x + 7y \leq 140 \end{cases}$$

27. Objective Function:

$$f(x, y) = 20x + 30y$$

Constraints:

$$\begin{cases} x \geq 0 \\ 12x + 6y \geq 120 \\ 9x - 6y \leq 144 \\ x + 4y \leq 12 \end{cases}$$

### APPLICATIONS

28. A plane carrying relief food and water can carry a maximum of 50,000 pounds and is limited in space to carrying no more than 6000 cubic feet. Each container of water weighs 60 pounds and takes up 1 cubic foot, and each container of food weighs 50 pounds and takes up 10 cubic feet. What is the region of constraint for the numbers of containers of food and water that the plane can carry?
29. A furniture company makes two kinds of sofas, the Standard model and the Deluxe model. The Standard model requires 40 hours of labor to build, and the Deluxe model requires 60 hours of labor to build. The finish of the Deluxe model uses both teak and fabric, while the Standard uses only fabric, with the result that each Deluxe sofa requires 5 square yards of fabric and each Standard sofa requires 8 square yards of fabric. Given that the company can use 200 hours of labor and 25 square yards of fabric per week building sofas, what is the region of constraint for the numbers of Deluxe and Standard sofas the company can make per week?

30. Sarah is looking through a clothing catalog, and she is willing to spend up to \$80 on clothes and \$10 for shipping. Shirts cost \$12 each plus \$2 shipping, and a pair of pants costs \$32 plus \$3 shipping. What is the region of constraint for the numbers of shirts and pairs of pants Sarah can buy?
31. Suppose you inherit \$75,000 from a previously unknown (and highly eccentric) uncle and that the inheritance comes with certain stipulations regarding investments. First, the dollar amount invested in bonds must not exceed the dollar amount invested in stocks. Second, a minimum of \$10,000 must be invested in stocks, and a minimum of \$5000 must be invested in bonds. Finally, a maximum of \$40,000 can be invested in stocks. What is the region of constraint for the dollar amounts that can be invested in the two categories of stocks and bonds?
32. A manufacturer produces two models of computers. The times (in hours) required for assembling, testing, and packaging each model are listed in the following table.

| Process  | Model X | Model Y |
|----------|---------|---------|
| Assemble | 2.5     | 3       |
| Test     | 2       | 1       |
| Package  | 0.75    | 1.25    |

The total times available for assembling, testing, and packaging are 4000 hours, 2500 hours, and 1500 hours, respectively. The profits per unit are \$50 for Model X and \$52 for Model Y. How many of each type should be produced to maximize profit? What is the maximum profit?

33. A manufacturer produces two types of fans. The times (in minutes) required for assembling, packaging, and shipping each type are listed in the following table.

| Process  | Type X | Type Y |
|----------|--------|--------|
| Assemble | 20     | 25     |
| Package  | 40     | 10     |
| Ship     | 10     | 7.5    |

The total times available for assembling, packaging, and shipping are 4000 minutes, 4800 minutes, and 1500 minutes, respectively. The profits per unit are \$4.50 for Type X and \$3.75 for Type Y. How many of each type should be produced to maximize profit? What is the maximum profit?

34. Ashley is making a set of patchwork curtains for her apartment. She needs a minimum of 16 yards of the solid material, at least 5 yards of the striped material, and at least 20 yards of the flowered material. She can choose between two sets of precut bundles. The olive-based bundle costs \$10 per bundle and contains 8 yards of the solid material, 1 yard of the striped material, and 2 yards of the flowered material. The cranberry-based bundle costs \$20 per bundle and includes 2 yards of the solid material, 1 yard of the striped material, and 7 yards of the flowered material. How many of each bundle should Ashley buy to minimize her cost and yet buy enough material to complete the curtains? What is her minimum cost?

35. A volunteer has been asked to drop off some supplies at a facility housing victims of a hurricane evacuation. The volunteer would like to bring at least 60 bottles of water, 45 first aid kits, and 30 security blankets on his visit. The relief organization has a standing agreement with two companies that provide victim packages. Company A can provide packages of 5 water bottles, 3 first aid kits, and 4 security blankets at a cost of \$1.50. Company B can provide packages of 2 water bottles, 2 first aid kits, and 1 security blanket at a cost of \$1.00. How many of each package should the volunteer pick up to minimize the cost? What total amount does the relief organization pay?
36. On your birthday your grandmother gave you \$25,000, but told you she would like you to invest the money for 10 years before you use any of it. Since you wish to respect your grandmother's wishes, you seek out the advice of a financial adviser. She suggests you invest at least \$15,000 in municipal bonds yielding 6% and no more than \$5000 in Treasury bills yielding 9%. How much should be placed in each investment so that income is maximized?
37. A boutique cell phone manufacturer produces two models: a retro model flip phone and a smart phone. The manufacturer's quota per day is to produce at least 100 flip phones and 80 smart phones. No more than 200 flip phones and 170 smart phones can be produced per day due to limitations on production. A total of at least 200 phones must be shipped every day.
- If the production costs are \$5 for a flip phone and \$7 for a smart phone, how many of each model should be produced on a daily basis to minimize cost and what would that cost be?
  - If each flip phone results in a \$2 loss but each smart phone results in a \$5 gain, how many of each model should be manufactured daily to maximize profit? What is the maximum profit if this number of phones is produced?

## 11.8 EXERCISES

 PRACTICE

Use graphing to approximate the real solution(s) of the following systems, and then verify that your answers are correct. See Examples 1 and 2.

$$1. \begin{cases} 3x - 2y = 6 \\ \frac{x^2}{4} + \frac{y^2}{9} = 1 \end{cases}$$

$$2. \begin{cases} x + 2y = 2 \\ \frac{x^2}{4} + y^2 = 1 \end{cases}$$

$$3. \begin{cases} x^2 + 4y^2 = 5 \\ x^2 + y^2 = 2 \end{cases}$$

$$4. \begin{cases} 4x^2 + y^2 = 5 \\ 4(x-2)^2 + y^2 = 5 \end{cases}$$

$$5. \begin{cases} y = x^2 \\ 2 - y = x^2 \end{cases}$$

$$6. \begin{cases} x^2 + (y-1)^2 = 4 \\ (x-3)^2 + (y-1)^2 = 1 \end{cases}$$

$$7. \begin{cases} y - x^2 = 1 \\ y + 2 = 4x^2 \end{cases}$$

$$8. \begin{cases} x^2 + y^2 = 10 \\ x^2 + y = -2 \end{cases}$$

$$9. \begin{cases} x = y^2 - 3 \\ x^2 + 4y^2 = 4 \end{cases}$$

$$10. \begin{cases} (x-1)^2 + (y-6)^2 = 9 \\ (x-1)^2 + (y+1)^2 = 16 \end{cases}$$

$$11. \begin{cases} (x+1)^2 + (y-1)^2 = 4 \\ (x+1)^2 + 4(y-1)^2 = 4 \end{cases}$$

$$12. \begin{cases} x^2 + y^2 = 1 \\ y = x^2 - 1 \end{cases}$$

$$13. \begin{cases} (x-2)^2 + y^2 = 4 \\ (x+2)^2 + y^2 = 4 \end{cases}$$

$$14. \begin{cases} x^2 + y^2 = 9 \\ x^2 + y^2 - 2x - 3 = 1 \end{cases}$$

$$15. \begin{cases} x^2 + y^2 = 9 \\ \frac{x^2}{9} + \frac{y^2}{25} = 1 \end{cases}$$

$$16. \begin{cases} x^2 + y^2 = 4 \\ -x^2 = 2y - 1 \end{cases}$$

$$17. \begin{cases} x^2 + \frac{y^2}{4} = 1 \\ y = 0 \end{cases}$$

$$18. \begin{cases} y = x^2 + 1 \\ y - 1 = x^3 \end{cases}$$

$$19. \begin{cases} 2y^2 - 3x^2 = 6 \\ 2y^2 + x^2 = 22 \end{cases}$$

$$20. \begin{cases} y = x^3 \\ y = \sqrt[3]{x} \end{cases}$$

$$21. \begin{cases} x = y^2 - 4 \\ x + 13 = 6y \end{cases}$$

$$22. \begin{cases} y = 2x^2 - 3 \\ y = -x^2 \end{cases}$$

$$23. \begin{cases} 2y = x^2 - 4 \\ x^2 + y^2 = 4 \end{cases}$$

$$24. \begin{cases} x^2 - y^2 = 5 \\ \frac{x^2}{25} + \frac{4y^2}{25} = 1 \end{cases}$$

Solve the following systems of nonlinear equations. Be sure to check for nonreal solutions. See Examples 3, 4, and 5.

$$25. \begin{cases} x^2 + y^2 = 30 \\ x^2 = y \end{cases}$$

$$26. \begin{cases} 3x^2 + 2y^2 = 12 \\ x^2 + 2y^2 = 4 \end{cases}$$

$$27. \begin{cases} x^2 - 1 = y \\ 4x + y = -5 \end{cases}$$

$$28. \begin{cases} x^2 + y^2 = 4 \\ 3x^2 + 4y^2 = 24 \end{cases}$$

$$29. \begin{cases} y = \frac{4}{x} \\ 2x^2 + y^2 = 18 \end{cases}$$

$$30. \begin{cases} xy = 5 \\ x^2 + y^2 = 10 \end{cases}$$

$$31. \begin{cases} y - x^2 = 4 \\ x^2 + y^2 = 16 \end{cases}$$

$$32. \begin{cases} y - x^2 = 6x \\ y = 4x \end{cases}$$

$$33. \begin{cases} 2x^2 + 3y^2 = 6 \\ x^2 + 3y^2 = 3 \end{cases}$$

$$34. \begin{cases} x^2 + y^2 = 4 \\ \frac{x^2}{4} - \frac{y^2}{8} = 1 \end{cases}$$

$$35. \begin{cases} 3x^2 - y = 3 \\ 9x^2 + y^2 = 27 \end{cases}$$

$$36. \begin{cases} \frac{1}{x} + \frac{1}{y} = 5 \\ \frac{1}{x} - \frac{1}{y} = -3 \end{cases}$$

$$37. \begin{cases} x + y^2 = 2 \\ 2x^2 - y^2 = 1 \end{cases}$$

$$38. \begin{cases} y - 2 = (x + 3)^2 \\ \frac{1}{3}y = (x - 1)^2 \end{cases}$$

$$39. \begin{cases} y - 2 = (x - 2)^2 \\ y + 2 = (x - 1)^2 \end{cases}$$

$$40. \begin{cases} y^2 + 2 = 2x^2 \\ y^2 = x^2 - 6 \end{cases}$$

$$41. \begin{cases} (x + 1)^2 + y^2 = 10 \\ \frac{(x - 2)^2}{4} + y^2 = 1 \end{cases}$$

$$42. \begin{cases} x^2 + y^2 = 10 \\ x^2 + y = 8 \end{cases}$$

$$43. \begin{cases} 2x = y - 1 \\ \frac{x^2}{25} + y^2 = 1 \end{cases}$$

$$44. \begin{cases} 2x^2 + y^2 = 4 \\ 2(x - 1)^2 + y^2 = 3 \end{cases}$$

$$45. \begin{cases} x^2 + 7y^2 = 14 \\ x^2 + y^2 = 3 \end{cases}$$

$$46. \begin{cases} x^2 + y^2 = 25 \\ y^2 = x - 5 \end{cases}$$

$$47. \begin{cases} y = x^3 + 8x^2 + 17x + 10 \\ -y = x^3 + 8x^2 + 17x + 10 \end{cases}$$

$$48. \begin{cases} \frac{x^2}{25} + \frac{y^2}{16} = 1 \\ x^2 + y^2 = 16 \end{cases}$$

$$49. \begin{cases} xy = 6 \\ (x-2)^2 + (y-2)^2 = 1 \end{cases}$$

$$50. \begin{cases} y^2 = x+1 \\ \frac{x^2}{5} + \frac{y^2}{6} = 1 \end{cases}$$

$$51. \begin{cases} y = x^3 - 1 \\ 3y = 2x - 3 \end{cases}$$

$$52. \begin{cases} y+5 = (x+1)^2 \\ y-3 = (x-3)^2 \end{cases}$$

$$53. \begin{cases} xy - y = 4 \\ (x-1)^2 + y^2 = 10 \end{cases}$$

$$54. \begin{cases} 2x^2 + 5y^2 = 16 \\ 4x^2 + 3y^2 = 4 \end{cases}$$

$$55. \begin{cases} y = \sqrt{x-4} + 1 \\ (x-3)^2 + (y-1)^2 = 1 \end{cases}$$

$$56. \begin{cases} y = \sqrt[3]{x} \\ \sqrt{y} = x \end{cases}$$

$$57. \begin{cases} y^2 - y - 12 = x - x^2 \\ y-1 + \frac{2x-12}{y} = 0 \end{cases}$$

$$58. \begin{cases} y = 7x^2 + 1 \\ x^2 + y^2 = 1 \end{cases}$$

$$59. \begin{cases} \frac{(y+2)^2}{(x+y)} = 1 \\ x = y^2 + 5y + 4 \end{cases}$$

$$60. \begin{cases} x = \sqrt{6y+1} \\ y = \sqrt{\frac{x^2+7}{2}} \end{cases}$$

$$61. \begin{cases} \frac{-2}{x^2} + \frac{1}{y^2} = 8 \\ \frac{9}{x^2} - \frac{2}{y^2} = 4 \end{cases}$$

$$62. \begin{cases} x^2 + 3x - 2y^2 = 5 \\ -4x^2 + 6y^2 = 3 \end{cases}$$

Draw the graph and determine whether the ordered pairs are solutions to the system of inequalities.

$$63. \begin{cases} x \geq 3 \\ y > 4 \end{cases} \quad \text{a. } (2,5) \quad \text{b. } (7,8) \quad \text{c. } (5,0) \quad \text{d. } (3,4)$$

$$64. \begin{cases} y \leq 2x+1 \\ y < 4 \\ y > x \end{cases} \quad \text{a. } (1,2) \quad \text{b. } (3,4) \quad \text{c. } (-1,-1) \quad \text{d. } (3,3)$$

$$65. \begin{cases} y \geq x^2 \\ y < x^3 \\ y \leq 4x \end{cases} \quad \text{a. } (2,2) \quad \text{b. } (2,4) \quad \text{c. } (2,8) \quad \text{d. } (3,9)$$

$$66. \begin{cases} y \geq x^2 - 2 \\ y \leq (x-2)^2 \\ 3y > 2x+12 \end{cases} \quad \text{a. } (2,5) \quad \text{b. } (7,8) \quad \text{c. } (5,0) \quad \text{d. } (3,4)$$

$$67. \begin{cases} x < 4 \\ y \geq \sqrt{x} \\ 2y > -x \end{cases} \quad \text{a. } (2,5) \quad \text{b. } (7,8) \quad \text{c. } (5,0) \quad \text{d. } (3,4)$$

Graph the following systems of inequalities. See Example 6.

$$68. \begin{cases} y < 2x \\ y > x^2 \end{cases} \quad 69. \begin{cases} y \leq 2x + 3 \\ y \geq 0 \\ x \geq 0 \end{cases} \quad 70. \begin{cases} y > x^2 \\ -3y \leq x - 9 \end{cases}$$

$$71. \begin{cases} y \leq x \\ 2y > -x \\ x < 4 \end{cases} \quad 72. \begin{cases} y \leq \sqrt{x} \\ 2y > (x-1)^2 - 4 \end{cases} \quad 73. \begin{cases} y > x^3 \\ y \leq \sqrt[3]{x} \\ y > 0 \end{cases}$$

$$74. \begin{cases} y \geq x^3 \\ y \geq -x^3 \\ y < 2(x+1) \end{cases} \quad 75. \begin{cases} x^2 + y^2 < 9 \\ -4y \geq x - 12 \end{cases} \quad 76. \begin{cases} y \leq \sin x \\ x \geq 0 \end{cases}$$

### 🔗 APPLICATIONS

77. The area of a certain rectangle is 45 square inches, and its perimeter is 28 inches. Find the dimensions of the rectangle.
78. The product of two positive integers is 88, and their sum is 19. What are the integers?
79. Jack takes half an hour longer than his wife does to make the 210-mile drive between two cities. His wife drives 10 miles an hour faster. How fast do the two drive?
80. To construct the two garden beds shown below, 48.5 meters of fencing are needed. The combined area of the beds is 95 square meters. There are two possibilities for the overall dimensions of the two beds. What are they?

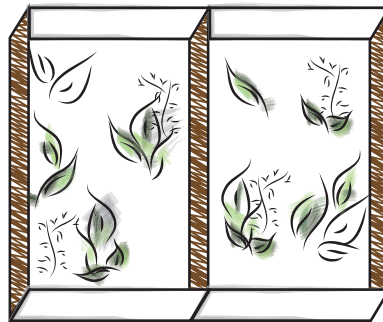

81. The product of two integers is  $-84$ , and their sum is  $-5$ . What are the integers?
82. Paul and Maria were driving the same 24-mile route, and they departed at the same time. After 20 minutes, Maria was 4 miles ahead of Paul. If it took Paul 10 minutes longer to reach their destination, how fast were they each driving?

83. The surface area of a certain right circular cylinder is  $54\pi \text{ cm}^2$  and the volume is  $54\pi \text{ cm}^3$ . Find the height  $h$  and the radius  $r$  of this cylinder. (**Hint:** The formulas for the volume and surface area of a right circular cylinder are as follows:  $V = \pi r^2 h$  and  $SA = 2\pi r h + 2\pi r^2$ .)

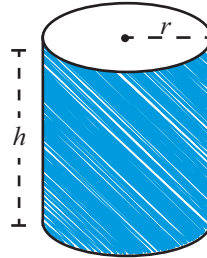

## 12.1 EXERCISES

 PRACTICE

Determine if each sequence is finite or infinite.

1. The sequence of odd numbers
2. 2, 4, 6, 8, 10, 12, ...
3. 1, 3, 5, 7, 9, 11
4. 3, 9, 27, 81, 243, ...
5. The sequence of the days of the week
6. 1, 0, 1, 0, 1, 0, 1, 0, ...
7. 1, 2, 3, 4, 5, 6, 7, ...
8. The sequence of letters in the alphabet
9. The sequence of the number of ants in a colony recorded daily

Determine the first five terms of each sequence whose  $n^{\text{th}}$  term is defined as follows. See Examples 1 and 2.

10.  $a_n = 7n - 3$
11.  $a_n = -3n + 5$
12.  $a_n = (-2)^n$
13.  $a_n = \frac{3n}{n+2}$
14.  $a_n = \frac{(-1)^n}{n^2}$
15.  $a_n = \frac{(-1)^{n+1} 2^n}{3^n}$
16.  $a_n = \left(-\frac{1}{3}\right)^{n-1}$
17.  $a_n = \frac{n^2}{n+1}$
18.  $a_n = \frac{(n-1)^2}{(n+1)^2}$
19.  $a_n = \frac{n(n+1)}{2} \cos(n\pi)$
20.  $a_n = (-2)^n + n$
21.  $a_n = (-n+4)^3 - 1$
22.  $a_n = \frac{2n^2}{3n-2}$
23.  $a_n = (-1)^n \sqrt{n}$
24.  $a_n = \frac{2^n}{n^2}$
25.  $a_n = 4n - 3$
26.  $a_n = -5n + 15$
27.  $a_n = 2^{n-2}$
28.  $a_n = 3^{-n-2}$
29.  $a_n = (3n)^n$
30.  $a_n = \sqrt[n]{64}$
31.  $a_n = \frac{5n}{n+3}$
32.  $a_n = \frac{n^2}{n+2}$
33.  $a_n = \frac{n^2 + n}{2}$
34.  $a_n = (-1)^n n$
35.  $a_n = \frac{(n+1)^2}{(n-1)^2}$
36.  $a_n = n^2 + n$
37.  $a_n = \frac{2n-1}{3n}$
38.  $a_n = \sqrt{3n} + 1$
39.  $a_n = -(n-1)^2$
40.  $a_n = (n-1)(n+2)(n-3)$
41.  $a_1 = 2$  and  $a_n = (a_{n-1})^2$  for  $n \geq 2$
42.  $a_1 = -2$  and  $a_n = 7a_{n-1} + 3$  for  $n \geq 2$
43.  $a_1 = 1$  and  $a_n = na_{n-1}$  for  $n \geq 2$
44.  $a_1 = -1$  and  $a_n = -a_{n-1} - 1$  for  $n \geq 2$

45.  $a_1 = 2$  and  $a_n = \sqrt{(a_{n-1})^2 + 1}$  for  $n \geq 2$

46.  $a_n = n \sin\left(\frac{n\pi}{2}\right)$

47.  $a_n = n^3 \sin\left(\frac{n\pi}{2}\right)$

48.  $a_n = 2^n \cos(n\pi)$

Find a possible formula for the general  $n^{\text{th}}$  term of each sequence. Answers may vary. See Example 3.

49. 5, 12, 19, 26, 33, ...

50. -2, 4, -8, 16, -32, ...

51. -1, 2, -6, 24, -120, ...

52.  $\frac{1}{3}, \frac{2}{4}, \frac{3}{5}, \frac{4}{6}, \frac{5}{7}, \dots$

53.  $1, \frac{1}{4}, \frac{1}{9}, \frac{1}{16}, \frac{1}{25}, \dots$

54.  $1, \frac{1}{2}, \frac{1}{6}, \frac{1}{24}, \frac{1}{120}, \dots$

55. -34, -25, -16, -7, 2, ...

56.  $\frac{3}{14}, \frac{2}{15}, \frac{1}{16}, 0, -\frac{1}{18}, \dots$

57.  $\frac{1}{4}, \frac{1}{2}, 1, 2, 4, \dots$

58. -1, -6, -11, -16, -21, ...

59.  $\frac{1}{2}, \frac{1}{2}, \frac{3}{8}, \frac{1}{4}, \frac{5}{32}, \dots$

60. 1, 4, 15, 64, 325, ...

Translate each expanded sum that follows into summation notation, and vice versa. Then evaluate the sum. See Examples 4 and 5.

61.  $\sum_{i=1}^7 (3i - 5)$

62.  $\sum_{i=1}^5 -3i^2$

63.  $1 + 8 + 27 + \dots + 216$

64.  $1 + 4 + 7 + \dots + 22$

65.  $\sum_{i=3}^{10} 5i^2$

66.  $9 + 16 + 25 + \dots + 81$

67.  $\sum_{i=1}^6 -3(2)^i$

68.  $\sum_{i=6}^{13} (i+3)(i-10)$

69.  $9 + 27 + 81 + \dots + 19,683$

Find a formula for the  $n^{\text{th}}$  partial sum  $S_n$  of each series. If the series is finite, determine the sum. If the series is infinite, determine if it converges or diverges, and if it converges, determine the sum. See Example 6.

70.  $\sum_{i=1}^{100} \left( \frac{1}{i+3} - \frac{1}{i+4} \right)$

71.  $\sum_{i=1}^{\infty} \left( \frac{1}{i+3} - \frac{1}{i+4} \right)$

72.  $\sum_{i=1}^{\infty} (2^i - 2^{i-1})$

73.  $\sum_{i=1}^{15} (2^i - 2^{i-1})$

74.  $\sum_{i=1}^{49} \left( \frac{1}{2i} - \frac{1}{2i+2} \right)$

75.  $\sum_{i=1}^{\infty} \left( \frac{1}{2i} - \frac{1}{2i+2} \right)$

76.  $\sum_{i=1}^{100} \ln\left(\frac{i}{i+1}\right)$  (Hint: Make use of a property of logarithms to rewrite the sum.)

77.  $\sum_{i=1}^{\infty} \ln\left(\frac{i}{i+1}\right)$  (Hint: Make use of a property of logarithms to rewrite the sum.)

78.  $\sum_{i=1}^{30} \left( \frac{1}{2i+5} - \frac{1}{2i+7} \right)$

79.  $\sum_{i=1}^{\infty} \left( \frac{1}{3i+1} - \frac{1}{3i+4} \right)$

80.  $\sum_{i=1}^{65} \ln\left(\frac{i}{i+1}\right)$

Determine the first five terms of each generalized Fibonacci sequence.

81.  $a_1 = 4$ ,  $a_2 = 7$ , and  $a_n = a_{n-2} + a_{n-1}$  for  $n \geq 3$
82.  $a_1 = -9$ ,  $a_2 = 1$ , and  $a_n = a_{n-2} + a_{n-1}$  for  $n \geq 3$
83.  $a_1 = 10$ ,  $a_2 = 20$ , and  $a_n = a_{n-2} + a_{n-1}$  for  $n \geq 3$
84.  $a_1 = -17$ ,  $a_2 = 13$ , and  $a_n = a_{n-2} + a_{n-1}$  for  $n \geq 3$
85.  $a_1 = 13$ ,  $a_2 = -17$ , and  $a_n = a_{n-2} + a_{n-1}$  for  $n \geq 3$

Determine the first five terms of each recursively defined sequence.

86.  $a_1 = 2$ ,  $a_2 = -3$ , and  $a_n = 3a_{n-1} + a_{n-2}$  for  $n \geq 3$
87.  $a_1 = 1$ ,  $a_2 = -3$ , and  $a_n = a_{n-1}a_{n-2}$  for  $n \geq 3$
88.  $a_1 = 3$ ,  $a_2 = 1$ , and  $a_n = (a_{n-2})^{a_{n-1}}$  for  $n \geq 3$

### APPLICATIONS

89. Suppose you buy one cow and a number of bulls. In year one, your cow gives birth to a female calf and continues to bear another female calf every year for the rest of her life. Assuming that every calf born is female, that each cow begins calving in her third year (at age two), and that your cows never die, determine the number of cows (do not count the bulls) you will have at the end of the 14<sup>th</sup> year.
90. You borrow \$638 to buy a new car stereo. You plan to pay this sum back with monthly payments of \$74. The interest rate on your loan is 6% compounded monthly (recall that's 0.5% per month). Let  $A_n$  be the amount you owe at the end of the  $n^{\text{th}}$  month. Find a recursive sequence to represent  $A_n$ . Use this sequence to find the amount owed after 4 months and the amount owed after 6 months. How many months will it take to pay off your loan?

### WRITING & THINKING

91. Beginning with yourself, create a sequence describing the number of biological predecessors you have in each of the past 7 generations of your family.
92. The Fibonacci sequence is quite prevalent in nature. Do some research on your own to find an occurrence in nature (other than population growth) of the Fibonacci sequence.

## TECHNOLOGY

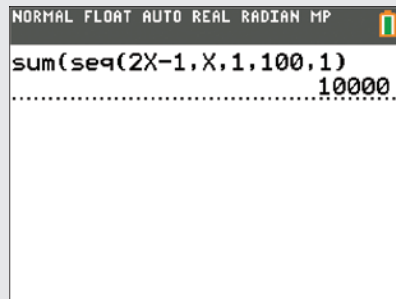

Thus, we have  $a_1 = 1$ ,  $d = 2$ ,  $n = 100$ , and  $a_n = a_{100} = 2(100) - 1 = 199$ . Given this information, we can use either partial sum formula to find the answer.

$$\begin{aligned} \text{Using the first formula, } S_{100} &= 100(1) + 2\left(\frac{(100-1)(100)}{2}\right) \\ &= 100 + 2\left(\frac{99 \cdot 100}{2}\right) = 10,000. \end{aligned}$$

$$\text{Using the second formula, } S_{100} = \left(\frac{100}{2}\right)(1 + 199) = 50 \cdot 200 = 10,000.$$

## 12.2 EXERCISES

## PRACTICE

Find the explicit formula for the general  $n^{\text{th}}$  term of each arithmetic sequence. See Example 1.

1.  $-2, 1, 4, 7, 10, \dots$
2.  $5, 7, 9, 11, 13, \dots$
3.  $7, 5, 3, 1, -1, \dots$
4.  $a_2 = 14$  and  $a_3 = 19$
5.  $a_1 = 5$  and  $a_5 = 41$
6.  $a_2 = 13$  and  $a_4 = 21$
7.  $a_3 = -9$  and  $d = -6$
8.  $a_{12} = 43$  and  $d = 3$
9.  $a_5 = 100$  and  $d = 19$
10.  $-37, -20, -3, 14, 31, \dots$
11.  $\frac{7}{2}, \frac{9}{2}, \frac{11}{2}, \frac{13}{2}, \frac{15}{2}, \dots$
12.  $15, 11, 7, 3, -1, \dots$
13.  $a_1 = 12$  and  $a_3 = -7$
14.  $a_{73} = 224$  and  $a_{75} = 230$
15.  $a_1 = -1$  and  $a_6 = -11$
16.  $a_5 = -\frac{5}{2}$  and  $d = \frac{3}{2}$
17.  $a_4 = 17$  and  $d = -4$
18.  $a_{34} = -71$  and  $d = -2$

Determine if each of the following sequences is arithmetic. If so, find the common difference.

19. The sequence of even numbers
20.  $1, 2, 4, 7, 11, 16, \dots$
21.  $1, 2, 3, 4, 5, 6, 7, \dots$
22. The Fibonacci sequence
23.  $1, 2, 4, 8, 16, 32, \dots$
24.  $42, 38, 34, 30, 26, 22, \dots$
25.  $0, 1, 0, 2, 0, 3, 0, 4, \dots$
26.  $12, 12, 12, 12, 12, \dots$

Given the initial term and the common difference, find the value of the 7<sup>th</sup> term of each of the arithmetic sequences.

27.  $a_1 = 1$  and  $d = 2$       28.  $a_1 = 4$  and  $d = -3$       29.  $a_1 = 0$  and  $d = \frac{1}{3}$

30.  $a_1 = 3$  and  $d = \pi$       31.  $a_1 = 8$  and  $d = -1$       32.  $a_1 = \frac{1}{2}$  and  $d = 3$

Given two terms, find the common difference and the first five terms of each of the arithmetic sequences.

33.  $a_1 = 5$  and  $a_2 = 7.5$

34.  $a_6 = 27$  and  $a_9 = 42$

35.  $a_7 = 49$  and  $a_{11} = 77$

36.  $a_4 = 76$  and  $a_8 = 156$

37.  $a_5 = -26$  and  $a_9 = 10$

38.  $a_8 = 45$  and  $a_{10} = 53$

Find the common difference of each of the following sequences. See Example 1.

39.  $\{5n - 3\}$

40.  $\left\{3n - \frac{1}{2}\right\}$

41.  $\{n + 6\}$

42.  $\{1 - 4n\}$

43.  $\{\sqrt{2} - 2n\}$

44.  $\{n\sqrt{3} + 5\}$

Use the given information about each arithmetic sequence to answer the question.

45. Given that  $a_1 = -3$  and  $a_5 = 5$ , what is  $a_{100}$ ?

46. In the sequence  $24, 43, 62, \dots$ , which term is 955?

47. In the sequence  $1, \frac{4}{3}, \frac{5}{3}, \dots$ , which term is 25?

48. Given that  $a_5 = -\frac{5}{3}$  and  $a_9 = 1$ , what is  $a_{62}$ ?

49. In the sequence  $-16, -9, -2, \dots$ , what is  $a_{20}$ ?

50. In the sequence  $\frac{1}{4}, \frac{7}{16}, \frac{5}{8}, \dots$ , which term is  $\frac{35}{8}$ ?

51. In the sequence  $2, 5, 8, 11, \dots$ , what is the 9<sup>th</sup> term?

52. In the sequence  $1, 3, 5, 7, \dots$ , what is the 6<sup>th</sup> term?

53. In the sequence  $16, 12, 8, 4, \dots$ , what is the 7<sup>th</sup> term?

54. In the sequence  $\frac{1}{2}, 2, \frac{7}{2}, 5, \dots$ , what is the 8<sup>th</sup> term?

55. In the sequence  $-2, 1, 4, 7, \dots$ , what is the 6<sup>th</sup> term?

56. In the sequence  $9, 6, 3, 0, \dots$ , what is the 10<sup>th</sup> term?

57. In the sequence  $5, 10, 15, 20, \dots$ , what is the 11<sup>th</sup> term?

58. In the sequence  $2\sqrt{2}, 4\sqrt{2}, 6\sqrt{2}, 8\sqrt{2}, \dots$ , what is the 7<sup>th</sup> term?

Find the value of the partial sum of each arithmetic sequence. See Example 4.

$$59. \sum_{i=1}^{100} (3i - 8) \qquad 60. \sum_{i=1}^{50} (-2i + 5) \qquad 61. \sum_{i=5}^{90} (4i + 9)$$

$$62. 3 + 11 + \cdots + 795 \qquad 63. 25 + 18 + \cdots + (-143) \qquad 64. -12 + 2 + \cdots + 674$$

$$65. \sum_{i=1}^{37} \left( -\frac{3}{5}i - 6 \right) \qquad 66. \sum_{i=100}^{200} (3i + 57) \qquad 67. \sum_{i=2}^{42} (2i - 22)$$

$$68. -90 + (-77) + \cdots + 92 \qquad 69. 7 + 3 + \cdots + (-101) \qquad 70. 4 + \frac{81}{20} + \cdots + 900$$

### APPLICATIONS

71. Cynthia borrows \$21,000, interest-free, from her parents to help pay for her college education, and promises that upon graduation she will pay back the sum beginning with \$1000 the first year and increasing the amount by \$1000 with each successive year. How many years will it take for her to repay the entire \$21,000?
72. A certain theatre is shaped so that the first row has 30 seats, and, moving toward the back, each successive row has two seats more than the previous one. If there are 40 rows, how many seats does the last row contain? How many seats are there altogether?
73. A brick mason spends a morning moving a pile of bricks from his truck to the work site by wheelbarrow. Each brick weighs two pounds, and on his first trip he transports 100 pounds. On each successive trip, as he tires, he decides to move one less brick. How many pounds of bricks has he transported after 20 trips?



74. The manager of a grocery store decides to create a display of soup cans by placing cans in a row on the floor and then stacking successive rows so that each level of the tower has one less can than the one below it. The manager wants the top row to have 5 cans, and the store has 290 cans that can be used for the display. If all of the cans are used, how many rows will the display have?
75. A man decides to lease a car and is told that his payment to the car dealership will be \$50 in the first month. He is also told that every month thereafter, for the next 60 months, his payments will increase by \$25. How much is his monthly payment after two years? How much has he paid in total after the first two years?

76. Your grandmother doesn't trust banks, so she decided to save for your college education by periodically adding money to a mason jar buried in her flower garden. She began the practice with \$65 and added \$15 every time she got her monthly paycheck. If she continued this routine for 18 years, how much money did she manage to save for you?

 TECHNOLOGY

Use a graphing utility to evaluate each of the following sums.

77.  $1.2 + 2.8 + 4.4 + 6.0 + 7.6 + \cdots + 28.4$       78.  $5 + \frac{5}{2} + 0 + \frac{-5}{2} + \cdots + \frac{-45}{2}$

79.  $\sum_{i=1}^{25} 89.47 - 7.35i$

80.  $\sum_{i=1}^{32} 4.12i + 17.54$

81.  $\sum_{i=49}^{83} (4.37i + 8.21)$

82.  $\sum_{i=23}^{79} \left( \frac{256i}{397} + \frac{57}{481} \right)$

## 12.3 EXERCISES

 PRACTICE

Find the explicit formula for the general  $n^{\text{th}}$  term of each geometric sequence. See Examples 1 and 2.

1.  $-3, -6, -12, -24, -48, \dots$

2.  $7, \frac{7}{2}, \frac{7}{4}, \frac{7}{8}, \frac{7}{16}, \dots$

3.  $2, -\frac{2}{3}, \frac{2}{9}, -\frac{2}{27}, \frac{2}{81}, \dots$

4.  $a_1 = 5$  and  $a_4 = 40$

5.  $a_2 = -\frac{1}{4}$  and  $a_5 = \frac{1}{256}$

6.  $a_1 = 1$  and  $a_4 = -0.001$

7.  $a_2 = \frac{1}{7}$  and  $r = \frac{1}{7}$

8.  $a_3 = \frac{9}{16}$  and  $r = -\frac{3}{4}$

9.  $a_3 = 9$ ,  $a_5 = 81$ , and  $r < 0$

10.  $-3, 9, -27, 81, -243, \dots$

11.  $3, 2, \frac{4}{3}, \frac{8}{9}, \frac{16}{27}, \dots$

12.  $-5, \frac{5}{4}, -\frac{5}{16}, \frac{5}{64}, -\frac{5}{256}, \dots$

13.  $a_3 = 28$  and  $a_6 = -224$

14.  $a_2 = -24$  and  $a_5 = -81$

15.  $a_5 = 1$  and  $a_6 = 2$

16.  $a_4 = \frac{343}{3}$  and  $r = 7$

17.  $a_2 = \frac{13}{17}$  and  $r = \frac{4}{3}$

18.  $a_4 = 8$ ,  $a_8 = 128$ , and  $r > 0$

Determine if each of the following sequences is geometric. If so, find the common ratio.

19. The sequence of odd numbers

20.  $4, 4, 4, 4, 4, \dots$

21.  $100, 50, 25, 12.5, 6.25, \dots$

22.  $2, 5, 11, 23, 47, \dots$

23.  $\frac{7}{8}, \frac{7}{4}, \frac{7}{2}, 7, 14, \dots$

24. The sequence of numbers called out at a Bingo game

25.  $7, 49, 343, 2401, \dots$

26.  $10, 15, 22.5, 33.75, \dots$

Given the two terms of a geometric sequence, find the common ratio and first five terms of the sequence.

27.  $a_1 = 8$  and  $a_2 = 24$

28.  $a_6 = \frac{1}{2}$  and  $a_9 = \frac{1}{54}$

29.  $a_7 = 16$  and  $a_{11} = 256$

30.  $a_4 = 108$  and  $a_8 = 8748$

31.  $a_5 = 100$  and  $a_9 = \frac{4}{25}$

32.  $a_8 = 100$  and  $a_{10} = 1$

Use the given information about each geometric sequence to answer the question.

33. Given that  $a_2 = -\frac{5}{2}$  and  $a_5 = \frac{5}{16}$ , what is  $a_{15}$ ?

34. Given that  $a_1 = 1$  and  $a_4 = \frac{8}{27}$ , what is the common ratio  $r$ ?

35. Given that  $a_3 = -2$  and  $a_4 = -16$ , what is  $a_{13}$ ?

36. Given that  $a_2 = 24$  and  $a_5 = 375$ , what is the common ratio  $r$ ?

37. Given that  $a_1 = -1$  and  $a_3 = -4$ , what is the common ratio  $r$ ?

38. Given that  $a_3 = 108$  and  $a_4 = -648$ , what is the common ratio  $r$ ?

39. Given that  $a_3 = -\frac{4}{25}$  and  $a_7 = -\frac{4}{15,625}$ , what is the common ratio  $r$ ?

Each of the following sums is a partial sum of a geometric sequence. Use this fact to evaluate the sums. See Examples 3 and 4.

40.  $\sum_{i=1}^{10} 3\left(-\frac{1}{2}\right)^i$

41.  $\sum_{i=5}^{20} 5\left(\frac{3}{2}\right)^i$

42.  $\sum_{i=10}^{40} 2^i$

43.  $1 - \frac{1}{2} + \dots + \frac{1}{16,384}$

44.  $2 + 6 + \dots + 39,366$

45.  $5 - \frac{5}{3} + \dots - \frac{5}{19,683}$

46.  $1 - 3 + \dots + 59,049$

47.  $\sum_{i=4}^{15} 5(-2)^i$

48.  $1 + \frac{3}{5} + \dots + \frac{243}{3125}$

Determine if each of the following infinite geometric series converges. If so, find the sum. See Example 5.

49.  $\sum_{i=0}^{\infty} -\frac{1}{2}\left(\frac{2}{3}\right)^i$

50.  $\sum_{i=1}^{\infty} \left(\frac{4}{5}\right)^i$

51.  $\sum_{i=0}^{\infty} \left(-\frac{9}{8}\right)^i$

52.  $\sum_{i=0}^{\infty} \left(-\frac{8}{9}\right)^i$

53.  $\sum_{i=5}^{\infty} \left(\frac{19}{20}\right)^i$

54.  $\sum_{i=0}^{\infty} (-1)^i$

55.  $\sum_{i=1}^{\infty} \frac{1}{3}(2)^{i-1}$

56.  $\sum_{i=0}^{\infty} 5\left(\frac{6}{11}\right)^i$

57.  $\sum_{i=4}^{\infty} \left(\frac{13}{24}\right)^i$

Write each of the following repeating decimal numbers as a fraction. See Example 5b.

58.  $1.\overline{65}$

59.  $0.\overline{123}$

60.  $-0.\overline{5}$

61.  $-3.\overline{8}$

62.  $0.\overline{029}$

63.  $9.\overline{98}$

 APPLICATIONS

64. A rubber ball is dropped from a height of 10 feet, and on each bounce it rebounds up to 80% of its previous height. How far has it traveled vertically at the moment when it hits the ground for the tenth time? If we assume it bounces an infinite number of times, what is the total vertical distance traveled?

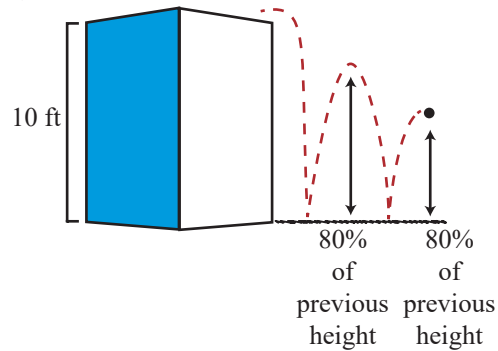

65. If \$10,000 is invested in a simple savings account with an annual interest rate of 4% compounded once a year, what is the value of the account after ten years?
66. If \$10,000 is invested in a simple savings account with an annual interest rate of 4% compounded once a month, what is the value of the account after ten years?
67. An ancient story about the game of chess tells of a king who offered to grant the inventor of the game a wish. The inventor replied, “Place a grain of wheat on the first square of the board, 2 grains on the second square, 4 grains on the third, and so on. The wheat will be my reward.” How many grains of wheat would the king have had to come up with? (There are 64 squares on a chessboard.)

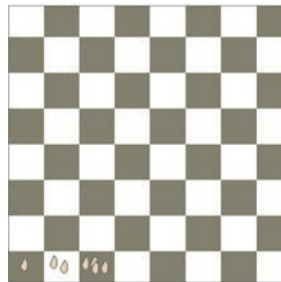

68. An isosceles right triangle is divided into two similar triangles, one of the new triangles is divided into two similar triangles, and this process is continued without end. If the shading pattern seen below is continued indefinitely, what fraction of the original triangle is shaded?

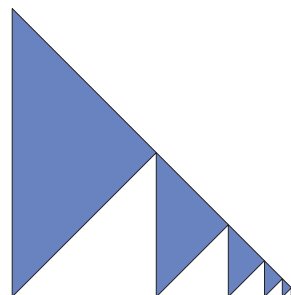

69. Each year the university admissions committee accepts 3% more students than they accepted in the previous year. If 2130 students were admitted in the first year of this trend, how many total students will have been admitted after 6 years?
70. On the day you were born, your parents deposited \$15,000 in a simple savings account for your college education. If the annual interest rate is 6.8%, compounded quarterly, how much money will be in the account when you begin college at the age of 18? What is the common ratio of this series?
71. Spamway, an internet advertising agency, uses e-mail forwards to collect addresses to which they send advertisements. They begin with an e-mail chain letter that they send to 10 people. According to the letter, each of those 10 people has to forward the e-mail to 10 more people or they will have 7 years of bad luck. Assuming the e-mails are received and forwarded only once a day and all the recipients are superstitious and follow the rules, how many e-mail addresses will Spamway have collected after 30 days? Is this series geometric? If so, find the common ratio.
72. Last summer you were a camp counselor for Sunny Days day camp. An arts and crafts project required you to distribute pieces of string (of different lengths) among the children. If you began with a piece of string 18 feet long and gave each child exactly half of your remaining string as you distributed, how long (in inches) was the seventh child's string?

 **WRITING & THINKING**

73. Is it possible for a geometric sequence to also be an arithmetic sequence? If so, give an example and if not, explain your reasoning.

 **TECHNOLOGY**

Use a graphing utility to evaluate each of the following sums.

74.  $1.2 + 1.44 + 1.728 + 2.0736 + \dots + 38.3376$

75.  $5 + \frac{5}{2} + \frac{5}{4} + \frac{5}{8} + \dots + \frac{5}{256}$

76.  $\sum_{i=53}^{92} (4.21)^i$

77.  $\sum_{i=13}^{54} \left(\frac{19}{436}\right)^i$

78.  $\sum_{i=23}^{79} \frac{25}{81} \left(\frac{57}{397}\right)^i$

79.  $\sum_{i=16}^{71} 3.42(5.26)^i$

## 12.4 EXERCISES

 PRACTICE

Find  $S_{k+1}$  for the given  $S_k$ .

1.  $S_k = \frac{1}{3(k+2)}$

2.  $S_k = \frac{k^2}{k(k-1)}$

3.  $S_k = \frac{k(k+1)(2k+1)}{4}$

4.  $S_k = \frac{1}{(2k-1)(2k+1)}$

Use the Principle of Mathematical Induction to prove the following statements.

5.  $1+2+3+4+\cdots+n = \frac{n(n+1)}{2}$

6.  $\frac{1}{2} + \frac{1}{2^2} + \frac{1}{2^3} + \cdots + \frac{1}{2^n} = 1 - \frac{1}{2^n}$

7.  $2+4+6+8+\cdots+2n = n(n+1)$

8.  $\sum_{i=1}^n \frac{1}{(2i-1)(2i+1)} = \frac{n}{2n+1}$

9.  $4^0 + 4^1 + 4^2 + \cdots + 4^{n-1} = \frac{4^n - 1}{3}$

10.  $2^n > n^2$  for all  $n \geq 5$ .

11.  $\frac{1}{1 \cdot 4} + \frac{1}{4 \cdot 7} + \frac{1}{7 \cdot 10} + \cdots + \frac{1}{(3n-2)(3n+1)} = \frac{n}{3n+1}$

$$12. 5^0 + 5^1 + 5^2 + \cdots + 5^{n-1} = \frac{5^n - 1}{4}$$

$$13. 5 + 10 + 15 + \cdots + 5n = \frac{5n(n+1)}{2}$$

$$14. n^2 \geq 100n \text{ for all } n \geq 100.$$

$$15. \left(1 + \frac{1}{1}\right)\left(1 + \frac{1}{2}\right)\left(1 + \frac{1}{3}\right) \cdots \left(1 + \frac{1}{n}\right) = n + 1$$

$$16. 3 + 5 + 7 + \cdots + (2n + 1) = n(n + 2)$$

$$17. 1 + 4 + 7 + 10 + \cdots + (3n - 2) = \frac{n}{2}(3n - 1)$$

$$18. -2 - 3 - 4 - \cdots - (n + 1) = -\frac{1}{2}(n^2 + 3n)$$

$$19. 3^n > 2n + 1 \text{ for all } n \geq 2.$$

$$20. 2^n > n, \text{ for all } n \geq 1$$

$$21. 1^3 + 2^3 + 3^3 + 4^3 + \cdots + n^3 = \frac{n^2(n+1)^2}{4}$$

$$22. 1 \cdot 2 + 2 \cdot 3 + 3 \cdot 4 + \cdots + n(n+1) = \frac{n(n+1)(n+2)}{3}$$

$$23. \text{ If } a > 1, \text{ then } a^n > 1.$$

$$24. 2^n > 4n \text{ for all } n \geq 5.$$

$$25. 1^4 + 2^4 + 3^4 + 4^4 + \cdots + n^4 = \frac{n(n+1)(2n+1)(3n^2+3n-1)}{30}$$

$$26. 1^5 + 2^5 + 3^5 + 4^5 + \cdots + n^5 = \frac{n^2(n+1)^2(2n^2+2n-1)}{12}$$

$$27. \frac{1}{\sqrt{1}} + \frac{1}{\sqrt{2}} + \frac{1}{\sqrt{3}} + \cdots + \frac{1}{\sqrt{n}} > \sqrt{n} \text{ for all } n \geq 2.$$

$$28. 1 + 3 + 5 + 7 + \cdots + (2n - 1) = n^2$$

Use the Principle of Mathematical Induction to prove the given properties. (Assume  $m$  and  $n$  are natural numbers and  $a$ ,  $b$ , and  $x$  are real numbers.)

$$29. (ab)^n = a^n b^n \text{ (Assume } a \text{ and } b \text{ are constants.)}$$

$$30. (a^m)^n = a^{mn} \text{ (Assume } a \text{ and } m \text{ are constants.)}$$

$$31. \text{ If } x_1 > 0, x_2 > 0, \dots, x_n > 0, \text{ then}$$

$$\ln(x_1 \cdot x_2 \cdot x_3 \cdots x_n) = \ln x_1 + \ln x_2 + \ln x_3 + \cdots + \ln x_n.$$

$$32. 5 \text{ is a factor of } (2^{2n-1} + 3^{2n-1}).$$

$$33. 64 \text{ is a factor of } (9^n - 8n - 1) \text{ for all } n \geq 2.$$

$$34. 3 \text{ is a factor of } (n^3 + 3n^2 + 2n).$$

35.  $n^3 - n + 3$  is divisible by 3.

36.  $5^n - 1$  is divisible by 4.

37.  $n(n+1)(n+2)$  is divisible by 6.

### APPLICATIONS

38. In the 19<sup>th</sup> century a mathematical puzzle was published telling of a mythical monastery in Benares, India with three crystal towers holding 64 disks made of gold. The disks are each of a different size and have holes in the middle so that they slide over the towers and sit in a stack with the largest on the bottom and the smallest on the top. The monks of the monastery were instructed to move all of the disks to the third tower following these three rules:

- Each disk sits over a tower except when it is being moved.
- No disk may ever rest on a smaller disk.
- Only one disk at a time may be moved.

According to the puzzle, when the monks complete their task, the world would end! To move  $n$  disks requires  $H(n) = 2^n - 1$  moves. Prove this is true through mathematical induction.

39. If there are  $n$  people in a room, and every person shakes hands with every other person exactly once, then exactly  $\frac{n(n-1)}{2}$  handshakes will occur. Prove this is true through mathematical induction.

40. Any monetary value of 4 cents or higher can be composed of twopence (a British two-cent coin) and nickels. Your basic step would be

$$4 \text{ cents} = \text{twopence} + \text{twopence}.$$

Use the fact that  $k = 2t + 5n$  where  $k$  is the total monetary value,  $t$  is the number of twopence, and  $n$  is the number of nickels, to prove  $P(k+1)$ . (**Hint:** There are 3 induction steps to prove.)

### WRITING & THINKING

41. What is wrong with this “proof” by induction?

**Proposition:** All horses are the same color. (In any set of  $n$  horses, all horses are the same color.)

**Basic Step:** If you have only one horse in a group, then all of the horses in that group have the same color.

**Induction Step:** Assume that in any group of  $n$  horses, all horses are the same color. Now take any group of  $n + 1$  horses. Remove the first horse from this group and the remaining  $n$  horses must be of the same color because of the hypothesis. Now replace the first horse and remove the last horse. Once again, the remaining  $n$  horses must be the same color because of the hypothesis. Since the two groups overlap, all  $n + 1$  horses must be the same color.

Thus by induction, any group of  $n$  horses are the same color.

## 12.5 EXERCISES

### PRACTICE

Consider each of the following situations and determine if each is a combination or permutation.

- double scoop options from 29 ice cream flavors
- a poker hand from a standard deck
- a board committee chosen from 15 candidates
- a seating chart for 24 students

Evaluate the following permutations. See Examples 5 and 6.

- ${}_4P_2$
- ${}_{15}P_2$
- ${}_6P_5$
- ${}_{19}P_{17}$

Evaluate the following combinations. See Example 7.

- ${}_6C_4$
- ${}_4C_2$
- ${}_{12}C_5$
- ${}_{21}C_{14}$

Determine how many different arrangements there are of the letters in each of the following words. See Example 8.

- ABYSS
- BANANA
- COLLEGE
- ALGEBRA
- MATHEMATICS
- FIBONACCI

Use the Binomial and Multinomial Theorems to expand each of the following expressions. See Examples 9, 10, and 11.

- $(3x + y)^5$
- $(x - 2y)^7$
- $(x - 3)^4$
- $(x^2 - y^3)^4$
- $(6x^2 + y)^5$
- $(4x + 5y^2)^6$
- $(7x^2 + 8y^2)^4$
- $(x^3 - y^2)^5$
- $(x + y + z)^2$
- $(a - 2b + c)^3$
- $(2x + 5)^6$
- $(2x + 3y - z)^3$
- What is the coefficient of the term containing  $x^3y$  in the expansion of  $(2x + y)^4$ ?
- What is the coefficient of the term containing  $x^4y^3$  in the expansion of  $(x^2 - 2y)^5$ ?
- Find the first four terms in the expansion of  $(x + 3y)^{16}$ .

34. Find the first three terms in the expansion of  $(2x+3)^{13}$ .
35. Find the first two terms in the expansion of  $(3x^{\frac{1}{4}}+5y)^{17}$ .
36. Find the 11<sup>th</sup> term in the expansion of  $(x+2)^{24}$ .
37. Find the 17<sup>th</sup> term in the expansion of  $(2x+1)^{21}$ .
38. Find the 9<sup>th</sup> term in the expansion of  $(x-6y)^{12}$ .

### APPLICATIONS

Use the Multiplication Principle of Counting to answer the following questions. See Examples 1 and 2.

39. Suppose you write down someone's phone number on a piece of paper, but then accidentally wash it along with your laundry. Upon drying the paper, all you can make out of the number is 42? - 3?7?. How many different phone numbers fit this pattern?
40. How many different 7-digit phone numbers contain no odd digits? (Ignore the fact that certain 7-digit sequences are disallowed as phone numbers.)
41. How many different 7-digit phone numbers do not contain the digit 9? (Ignore the fact that certain 7-digit sequences are disallowed as phone numbers.)
42. A certain combination lock allows the buyer to set any combination of five letters, with repetition allowed, but each of the letters must be A, B, C, D, E, or F. How many combinations are possible?
43. In how many different orders can 15 runners finish a race, assuming there are no ties?
44. How many different 4-letter radio-station names can be made, assuming the first letter must be a K or a W? Assume repetition of letters is allowed.
45. How many different 4-letter radio-station names can be made from the call-letters K, N, I, T, assuming the letter K must appear first? Each of the four letters can be used only once.
46. Three men and three women line up in a row for a photograph, and decide men and women should alternate. In how many different ways can this be done? (Don't forget that the left-most person can be a man or a woman.)
47. How many different ways can a 10-question multiple choice test be answered, assuming every question has 5 possible answers?
48. How many different ways can your 12 favorite novels be arranged in a row?
49. How many different 6-character license plates can be formed if all 26 letters and 10 numerical digits can be used with repetition?

50. How many different 6-character license plates can be formed if all 26 letters and 10 numerical digits can be used without repetition?
51. How many different 6-character license plates can be formed if the first 3 places must be letters and the last 3 places must be numerical digits? (Assume repetition is not allowed.)
52. A box of crayons comes with 8 different colored crayons arranged in a single row. How many different ways can the crayons be ordered in the box?

Express the answer to the following permutation problems using permutation notation  $({}_nP_k)$  and numerically. See Examples 3, 4, and 5.

53. Suppose you have a collection of 30 cherished math books. How many different ways can you choose 12 of them to arrange in a row?
54. In how many different ways can first-place, second-place, and third-place be decided in a 15-person race?
55. Suppose you need to select a user-ID for a computer account, and the system administrator requires that each ID consist of 8 characters with no repetition allowed. The characters you may choose from are the 26 letters of the alphabet (with no distinction between uppercase and lowercase) and the 10 digits. How many choices for a user-ID do you have?
56. How many different 5-letter “words” (they don’t have to be actual English words) can be formed from the letters in the word PLASTIC?
57. Seven children rush into a room in which six chairs are lined up in a row. How many different ways can six of the seven children choose a chair to sit in? (The seventh remains standing.) How does the answer differ if there are seven chairs in the room?
58. At a meeting of 17 people, a president, vice president, secretary, and treasurer are to be chosen. How many different ways can these positions be filled?
59. Given 26 building blocks, each with a different letter of the alphabet printed on it, how many different 3-letter “words” can be formed?

Express the answer to the following combination problems using combination notation  $({}_nC_k)$  and numerically. See Example 7.

60. In many countries, it is not uncommon for quite a few political parties to have their representatives in power. Suppose a committee composed of 10 Conservatives, 13 Liberals, 6 Greens, and 4 Socialists decides to form a sub-committee consisting of 3 Conservatives, 4 Liberals, 2 Greens and 1 Socialist. How many different such sub-committees can be formed?
61. A trade-union asks its members to select 3 people, from a slate of 7, to serve as representatives at a national meeting. How many different sets of 3 can be chosen?

62. Many lottery games are set up so that players select a subset of numbers from a larger set and the winner is the person whose selection matches that chosen by some random mechanism. The order of the numbers is irrelevant. How many choices of six numbers can be made from the numbers 1 through 49?
63. How many different lines can be drawn through a set of nine points in the plane, assuming that no three of the points are collinear? (Points are said to be *collinear* if a single line containing them can be drawn.)
64. Suppose you are taking a 10-question True-False test, and you are guessing that the professor has arranged it so that five of the answers are True and five are False. How many different ways are there of marking the test with five True answers and five False answers?
65. A caller in a Bingo game draws 5 marked ping pong balls from a basket of 75 and calls the numbers out to the players. How many different combinations are possible assuming that the order is irrelevant?

Use the techniques seen in this section, to answer the following questions.

66. How many different ways are there of choosing five cards from a standard 52-card deck and arranging them in a row? How many different five-card hands can be dealt from a standard 52-card deck?
67. Suppose you have 10 Physics texts, 8 Computer Science texts, and 13 Math texts. How many different ways can you select 4 of each to take with you on vacation?
68. Suppose you have 10 Physics texts, 8 Computer Science texts, and 13 Math texts. How many different ways can you select 4 of each and then arrange them in a row on a shelf, so that the books are grouped by discipline?
69. A certain ice cream store has four different kinds of cones and 28 different flavors of ice cream. How many different single-scoop ice cream cones is it possible to order at this ice cream store?
70. If a local pizza shop has three different types of crust, two different kinds of sauce, and five different toppings, how many different one topping pizzas can be ordered?
71. A man has 8 different shirts, 4 different shorts, and 3 different pairs of shoes. How many different outfits can the man choose from?
72. A couple wants to have three children. They want to know the different possible gender outcomes for birth order. How many different birth orders are possible?
73. A student has to make out his schedule for classes next fall. He has to take a math class, a science class, an elective, a history class, and an English class. There are three math classes to choose from, two science classes, four electives, three history classes, and four English classes. How many different schedules could the student have?

74. A basketball team has 12 different people on the team. The team consists of three point guards, two shooting guards, one weak forward, three power forwards, and three centers. How many different starting line-ups are possible? (The starting line-up will consist of one player in each of the 5 positions.)
75. How many 5-letter strings can be formed using the letters V, W, X, Y, and Z, if the same letter cannot be repeated?
76. If at the racetrack nine greyhounds are racing against each other, how many different first, second, and third place finishes are possible?
77. A basketball tryout has four distinct positions available on the team. If 25 people show up for tryouts, how many different ways can the four positions be filled?
78. If a trumpet player is practicing eight different pieces of music, in how many different orders can he play his pieces of music?
79. A pizza place has 12 total toppings to choose from. How many different 4-topping pizzas can be ordered?
80. How many different 5-digit numbers can be formed using each of the numbers 6, 8, 1, 9, and 4?
81. If eight cards are chosen randomly from a deck of 52, how many possible groups of eight can be chosen?
82. A baseball team has 15 players on the roster and a batting line-up consists of 9 players. How many different batting line-ups are possible?
83. How many different ways can two red balls, one orange ball, one black ball, and three yellow balls be arranged?

 **WRITING & THINKING**

Pascal's triangle is a triangular arrangement of binomial coefficients, the first few rows of which appear as follows:

$$\begin{array}{ccccccc}
 & & & & 1 & & & & \\
 & & & & 1 & 1 & & & \\
 & & & 1 & 2 & 1 & & & \\
 & & 1 & 3 & 3 & 1 & & & \\
 & 1 & 4 & 6 & 4 & 1 & & & \\
 & & & & \vdots & & & & 
 \end{array}$$

Each number (aside from those on the perimeter of the triangle) is the sum of the two numbers diagonally adjacent to it in the previous row. Pascal's triangle is a useful way of generating binomial coefficients, with the  $n^{\text{th}}$  row containing the coefficients of a binomial raised to the  $(n-1)^{\text{st}}$  power. It can also be used to suggest useful relationships between binomial coefficients. Prove each of the following such relationships algebraically.

$$84. \binom{n}{k} = \binom{n-1}{k-1} + \binom{n-1}{k} \quad (\text{Note that this is a restatement of how Pascal's triangle is formed.})$$

$$85. \binom{n}{k} = \binom{n}{n-k} \qquad 86. \binom{n}{0} = \binom{n}{n} = 1$$

$$87. \binom{n}{0} + \binom{n}{1} + \cdots + \binom{n}{n} = 2^n$$

**(Hint:** Use the Binomial Theorem on  $(x + y)^n$  for a convenient choice of  $x$  and  $y$ .)

## 12.6 EXERCISES

### PRACTICE

Below is the given probability that an event will occur; find the probability that it will not occur.

1.  $P(E) = \frac{2}{5}$
2.  $P(E) = 0.72$
3.  $P(E) = \frac{4}{13}$
4.  $P(E) = 0.15$
5.  $P(E) = \frac{2}{3}$
6.  $P(E) = 0.49$

Apply the formulas for the probabilities of intersection and union to the following sets and determine **a.**  $P(E \cap F)$  and **b.**  $P(E \cup F)$ . Let  $n(S)$  equal the size of the sample space.

7.  $n(S) = 8, E = \{2, 5\}, F = \{3, 7, 9\}$
8.  $n(S) = 10, E = \{1, 2, 5\}, F = \{1, 2, 3, 5\}$
9.  $n(S) = 5, E = \{4, B\}, F = \{3\}$
10.  $n(S) = 8, E = \{A\}, F = \{B, C, D, E\}$
11.  $n(S) = 4, E = \{1, \beta\}, F = \{\alpha, 2\}$
12.  $n(S) = 12, E = \{A, C, g, 5, n, 7, 8, t, L\}, F = \{n, 6\}$
13.  $n(S) = 16, E = \{1, 2, A, m, 13, Y, 8\}, F = \{1, 9, 11, m\}$
14.  $n(S) = 11, E = \{m, 7, D, 4, \theta\}, F = \{\phi, D, 3, 7, m, \Sigma\}$

Determine the sample space of each of the following experiments.

15. A coin is flipped four times and the result recorded after each flip.
16. A card is drawn at random from the 13 hearts.
17. A coin is flipped and a card is drawn at random from the 13 hearts.
18. A quadrant of the Cartesian plane is chosen at random.
19. A slot machine lever is pulled; there are 3 slots, each of which can hold 6 different values.
20. An individual die is rolled twice and each of the two results is recorded.
21. At a casino, a roulette wheel spins until a ball comes to rest in one of the 38 pockets.
22. A lottery drawing consists of 6 randomly drawn numbers from 1 to 20; the order of the numbers matters in this case, and repetition is possible.

 APPLICATIONS

23. An ordinary die is rolled. Find the probability of rolling
- a 3 or higher.
  - an even composite number.
24. A card is drawn from a standard 52-card deck. Find the probability of drawing
- a face card (jack, queen, or king) in the suit of hearts.
  - anything but an ace.
  - a black (clubs or spades) card that is not a face card.
25. A coin is flipped three times. Find the probability of getting
- Heads exactly twice.
  - the sequence Heads, Tails, Heads.
  - two or more Heads.
26. A state lottery game is won by choosing the same six numbers (without repetition) as those selected by a mechanical device. The numbers are picked from the set  $\{1, 2, \dots, 49\}$ , and the order of the numbers chosen is immaterial. What is the probability of winning?
27. What is the probability that a four-digit ATM PIN chosen at random ends in 7, 8, or 9?
28. Assume the probability of a newborn being male is one-half. What is the probability that a family with five children has exactly three boys?
29. What is the probability that a 9-digit driver's license number chosen at random will not have an 8 as a digit?
30. A roulette wheel in a casino has 38 pockets: 18 red, 18 black, and 2 green. Spinning the wheel causes a small ball to randomly drop into one of the pockets. All of the pockets are equally likely. The wheel is spun twice. Find the probability of getting
- green both times.
  - black at least once.
  - red exactly once.
31. There is a 25% chance of rain for each of the next 2 days. What is the probability that it will rain on one of the days but not the other?
32. A pair of dice is rolled. Find the probability that the sum of the top faces is
- seven.
  - seven or eleven.
  - an even number or a number divisible by three.
  - ten or higher.
33. A card is drawn from a standard 52-card deck. Find the probability of drawing
- a face card or a diamond.
  - a face card but not a diamond.
  - a red face card or a king.
34. A state lottery game is won by choosing the same six numbers (without repetition) as those selected by a mechanical device. The numbers are picked from the set  $\{1, 2, \dots, 49\}$ , and the order of the numbers chosen is immaterial. What is the probability of winning if someone buys 1000 tickets? (No two tickets have the same set of six numbers.) How many tickets would have to be bought to raise the probability of winning to one-half?

35. Two cards are drawn at random from a standard 52-card deck. What is the probability of them both being aces if
- the first card is drawn, looked at, placed back in the deck, and the deck is then shuffled before the second card is drawn?
  - the two cards are drawn at the same time?
36. What is the probability of being dealt a five-card hand (from a standard 52-card deck) that has four cards of the same rank?
37. The probability of rain today is 75%, and the probability that Bob will forget to put the top up on his convertible is 25%. What is the probability of the inside of his car getting wet?
38. What is the probability of drawing 3 face cards in a row, without replacement, from a 52-card deck?
39. Two dice are rolled, and the difference is calculated by subtracting the smaller value from the larger value. Therefore, the difference may range from 0 to 5. Find the probability of each of the following differences:
- 0
  - 1
  - 4
40. A letter is randomly chosen from the word MISSISSIPPI. What is the probability of the letter being an S?
41. Mike works in a company of 100 employees. If this year five people in the company are going to be randomly laid off, what is the probability that Mike will get laid off?
42. A pack of M&M's contains 10 yellow, 15 green, and 20 red pieces. What is the probability of choosing a green M&M out of the pack?
43. A jar of cookies has 3 sugar cookies, 4 chocolate chip cookies, and 2 peanut butter cookies. What is the probability of randomly choosing a peanut butter cookie out of the jar?
44. A big box of crayons contains 4 different blues, 3 different reds, 5 different greens, and 2 different yellows. What is the probability of randomly choosing a yellow crayon out of the box?
45. A bag of marbles contains 3 blue marbles, 2 red marbles, and 5 orange marbles. What is the probability of randomly picking a blue marble out of the bag?
46. Every week a teacher of a class of 25 randomly chooses a student to wash the blackboards. If there are 15 girls in the class, what is the probability that the student selected will be a boy?
47. If in a raffle 135 tickets are sold, how many tickets must be purchased for an individual to have a 20% chance of winning?
48. Zach is running for student council. At Zach's school the student council is chosen randomly from all qualified candidates. If there are 42 candidates running, including Zach, and a total of three positions, what is the probability that Zach will be selected for the council?

If  $h > 0$ , since in this case  $|h| = h$ , the difference quotient becomes

$$\frac{|0+h|}{h} = \frac{|h|}{h} = \frac{h}{h} = 1,$$

regardless of the value of  $h$ . On the other hand, if  $h < 0$ , then  $|h| = -h$ , so

$$\frac{|0+h|}{h} = \frac{|h|}{h} = \frac{-h}{h} = -1,$$

and again,  $h$  can be any negative real number.

Notice that our results indicate that any secant line corresponding to a positive  $h$ -value will coincide with the right branch of the graph, while all secant lines obtained from  $h < 0$  coincide with the left branch.

What does all this mean? There is no single real number being approached by the difference quotients or slopes as  $h$  is getting smaller. Graphically, this means that there is no tangent, no single line that would “best capture” the trend of the graph, none that would best align itself to the graph of  $A(x)$  at  $(0,0)$ . The graph has a “sharp turn” there, making it impossible for a tangent line to exist, as shown in Figure 6. We also express this fact by saying that the graph is not “smooth” at  $x = 0$ .

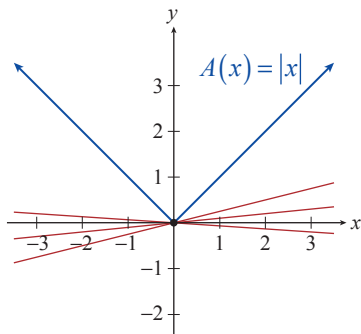

FIGURE 6

## 13.1 EXERCISES

### 💡 PRACTICE

Construct and simplify the difference quotient at  $c$  with increment  $h$ . See Example 1.

1.  $f(x) = -7x + 5$
2.  $g(x) = 2x + 13$
3.  $p(x) = x^2 - 5x + 3$
4.  $g(x) = 9x^2 - 17$
5.  $f(x) = \frac{1}{6-x}$
6.  $f(x) = \frac{-x}{3x+1}$
7.  $g(x) = \ln x$
8.  $p(x) = \frac{x^2-1}{x+3}$
9.  $f(x) = 3\sqrt{x-2}$

Use the difference quotient of each function for one appropriate value of  $c$  to determine the average rate of change of the function over each of the given intervals. See Example 2.

10.  $f(x) = -7x + 5$ 
  - a.  $[5, 7]$
  - b.  $[5, 5.5]$
  - c.  $[4.9, 5]$
11.  $g(x) = 2x + 13$ 
  - a.  $[-3, -1]$
  - b.  $[-1, 0]$
  - c.  $[-1.0001, -1]$
12.  $p(x) = x^2 - 5x + 3$ 
  - a.  $[1, 2]$
  - b.  $[0.9, 1]$
  - c.  $[1, 1.0001]$

13.  $f(x) = \frac{1}{6-x}$       a. [2,3]      b. [3,3.1]      c. [2.999,3]
14.  $f(x) = 3\sqrt{x-2}$       a. [3,4]      b. [2.9,3]      c. [3,3.0001]

Estimate the slope of the tangent line shown in the given graph.

15.

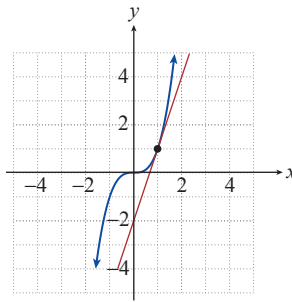

16.

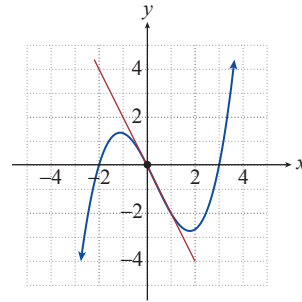

17.

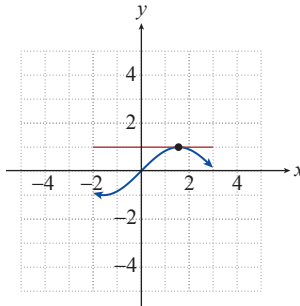

18.

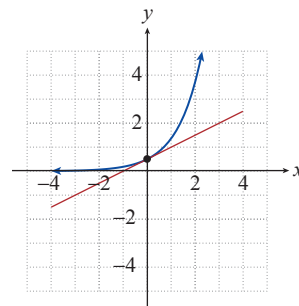

19.

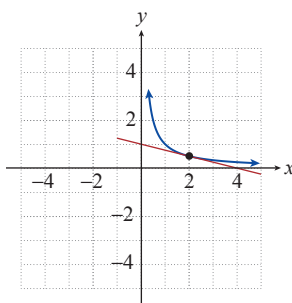

20.

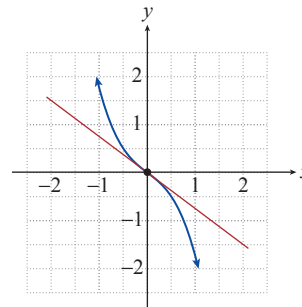

Use difference quotients to approximate the slope of the tangent to the graph of the function at the given point. Use at least five different  $h$ -values that are decreasing in magnitude. (Answers will vary.)

21.  $f(x) = 1 - 2x$ ; (1, -1)
22.  $g(x) = \frac{5}{4}x - 8$ ; (8, 2)
23.  $h(x) = \frac{1}{3}x^2 - 1$ ; (3, 2)
24.  $F(x) = 3 + x - \frac{x^2}{2}$ ; (4, -1)
25.  $G(x) = \frac{1}{4}x^3 - x + 1$ ; (-2, 1)
26.  $k(x) = 10 - x^{\frac{3}{2}}$ ; (4, 2)
27.  $H(x) = \ln x + 1$ ; ( $e$ , 2)
28.  $u(x) = \cos x$ ; ( $\frac{\pi}{2}$ , 0)
29.  $v(x) = \log(2x) - 1$ ; (5, 0)
30.  $w(x) = \tan x$ ; (0, 0)
31.  $p(x) = -x^4 + 1$ ; (1, 0)
32.  $q(x) = x^5 - x + 3$ ; (0, 3)

 APPLICATIONS

33. An arrow is shot into the air and its height in feet after  $t$  seconds is given by the function  $f(t) = -16t^2 + 80t$ . The graph of the curve  $y = f(t)$  is shown.

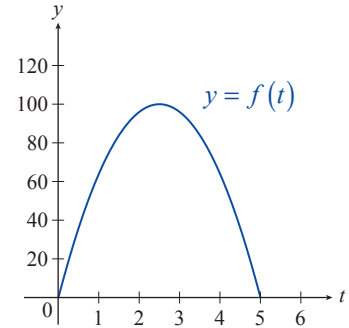

- Find the height of the arrow when  $t = 2$  seconds.
  - Find the instantaneous velocity of the arrow when  $t = 2$  seconds.
  - Find the slope of the line tangent to the curve at  $t = 2$  seconds.
  - Find the time it takes the arrow to reach its peak.
34. Suppose that a sailboat is observed, over a period of 5 minutes, to travel a distance from a starting point according to the function  $s(t) = t^3 + 60t$ , where  $t$  is time in minutes and  $s$  is the distance traveled in meters.
- How far will it travel during the first 6 seconds?
  - What is the average velocity during the first 6 seconds?
  - Estimate how fast the boat is moving at the starting point.
  - Estimate how fast the boat is moving at the end of 3 minutes.
35. A model rocket is fired vertically upward. The height after  $t$  seconds is  $h(t) = 192t - 16t^2$  feet.
- What will be its height at the end of the first second?
  - What is the average velocity of the rocket during the first second?
  - Estimate the instantaneous velocity at  $t = 0$  seconds.
  - Estimate the instantaneous velocity at  $t = 4$  seconds.
  - When will the velocity be 0? (**Hint:** You may want to start with the initial velocity you found in part a. and use the fact that under the influence of gravity, when air resistance is ignored, vertical upward velocity decreases by 32 ft/s every second. Once you have a guess, test it by a table of difference quotients.)
36. A particle moving in a straight line is at a distance of  $s(t) = 2.5t^2 + 18t$  feet from its starting point after  $t$  seconds, where  $0 \leq t \leq 12$ . Estimate the instantaneous velocity at **a.**  $t = 6$  seconds and **b.**  $t = 9$  seconds.
37. The distance, in meters, traveled by a moving particle in  $t$  seconds is given by  $d(t) = 3t(t+1)$ . Estimate the instantaneous velocity at **a.**  $t = 0$  seconds, **b.**  $t = 2$  seconds, and **c.** at time  $t_0$ . (**Hint:** Write the difference quotient corresponding to  $t = t_0$ , simplify, and try to find the value being approached by the expression as  $h$  decreases.)
38. The distance, in meters, traveled by a moving particle in  $t$  seconds is given by  $d(t) = t^2 - 3t$ . Estimate the instantaneous velocity at **a.**  $t = 0$  seconds, **b.**  $t = 4$  seconds, and **c.** at time  $t_0$ . (See the hint given in part c. of the previous problem.)

39. After start, on a straight stretch of the track, a race car's velocity changes according to the function  $v(t) = -1.8t^2 + 18t$ , when  $0 \leq t \leq 10$ ,  $t$  is measured in seconds, and  $v(t)$  is measured in meters per second.
- When does peak velocity occur and what is it? (**Hint:** The graph of  $v(t)$  may be helpful.)
  - When does peak deceleration occur?
  - Use difference quotients to estimate peak deceleration. Approximately what multiple of  $g \approx 9.81 \text{ m/s}^2$  have you obtained?
40. If we ignore air resistance, a falling body will fall  $16t^2$  feet in  $t$  seconds.
- How far will it fall between  $t = 2$  and  $t = 2.1$ ?
  - What is its average velocity between  $t = 2$  and  $t = 2.1$ ?
  - Estimate its instantaneous velocity at  $t = 2$ .

### TECHNOLOGY

Use a graphing utility to graph  $f(x)$  along with three secant lines at the indicated  $x$ -value, corresponding to the difference quotients with  $h$ -values of 0.2, 0.1, and 0.01, respectively. Can you come up with a possible equation for the tangent? Use technology to test your conjecture.

- |  |  |
|--|--|
| 41. $f(x) = x^2$ ; $x = 2$             | 42. $f(x) = -x^3 + x + 1$ ; $x = \frac{\sqrt{3}}{3}$ |
| 43. $f(x) = \sin x + \cos x$ ; $x = 0$ | 44. $f(x) = 3\sqrt{x}$ ; $x = 4$                     |

Use a graphing utility to graph the given function  $f(x)$  along with  $D(x) = \frac{f(x+0.001) - f(x)}{0.001}$  in the same coordinate system. Explain how the function values of  $D(x)$  are reflected on the graph of  $f(x)$ .

- |                     |                       |
|---------------------|-----------------------|
| 45. $f(x) = x^4$    | 46. $f(x) = x(3 - x)$ |
| 47. $f(x) = \sin x$ | 48. $f(x) = \ln x$    |

Use a graphing utility to find the  $x$ -values at which the graph of  $f(x)$  does not have a tangent line. Explain.

- |                           |                                    |
|---------------------------|------------------------------------|
| 49. $f(x) = - x - 1  + 1$ | 50. $f(x) =  x^2 - 4 $             |
| 51. $f(x) =  \ln x $      | 52. $f(x) = (x - 1)^{\frac{2}{3}}$ |

## 13.2 EXERCISES

## PRACTICE

Use the graph of the function to find the indicated limit (if it exists).

1.  $\lim_{x \rightarrow 3} f(x)$

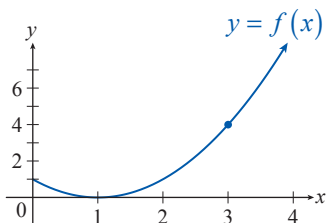

2.  $\lim_{x \rightarrow 1} g(x)$

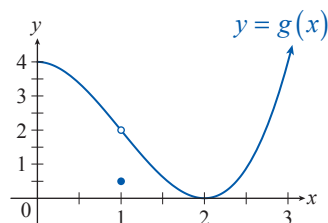

3.  $\lim_{x \rightarrow 0} h(x)$

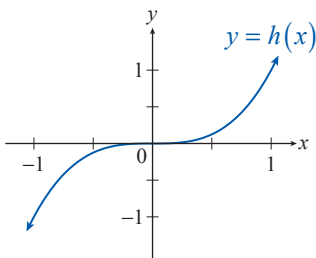

4.  $\lim_{x \rightarrow 1} k(x)$

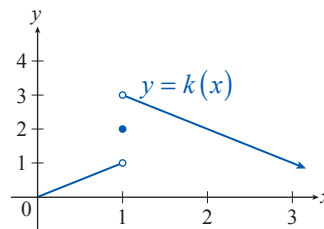

Create a table of values to estimate the value of the indicated limit without graphing the function. Choose the last  $x$ -value so that it is no more than 0.001 units from the given  $c$ -value.

5.  $\lim_{x \rightarrow \sqrt{2}} \frac{x^2 - 2}{x - \sqrt{2}}$

6.  $\lim_{x \rightarrow 3} \frac{x^3 - 9x^2 + 27x - 27}{x - 3}$

7.  $\lim_{x \rightarrow 1} \frac{x^{10} - 1}{x - 1}$

8.  $\lim_{x \rightarrow 0} \frac{4 \sin x}{3x}$

9.  $\lim_{x \rightarrow \pi} \frac{2 \cos x - 1}{1 - \sin x}$

10.  $\lim_{x \rightarrow 7} \frac{x^2 - 49}{x - 7}$

11.  $\lim_{x \rightarrow 7^+} \frac{x^2 + 49}{x - 7}$

12.  $\lim_{x \rightarrow 0^+} \frac{\sqrt{4+x}}{x}$

Use one-sided limit notation to describe the behavior of the function near its vertical asymptote(s).

13.

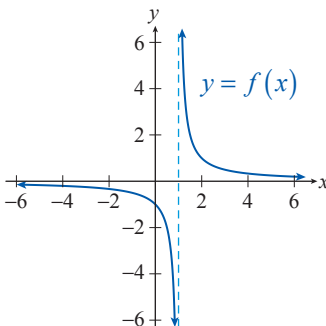

14.

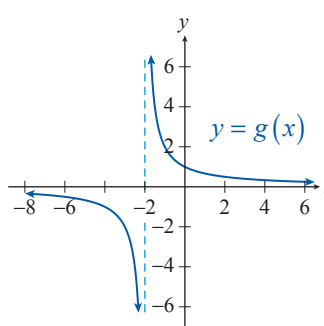

15.

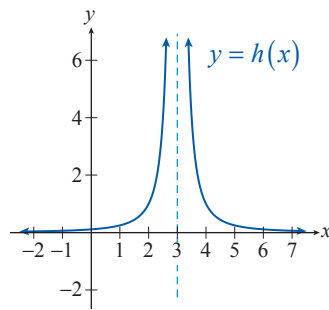

16.

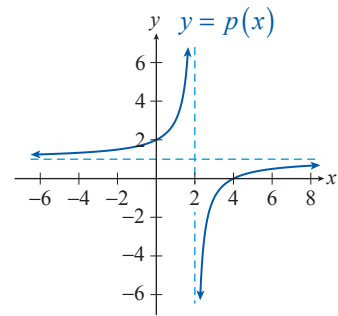

17.

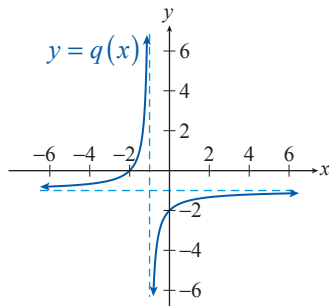

18.

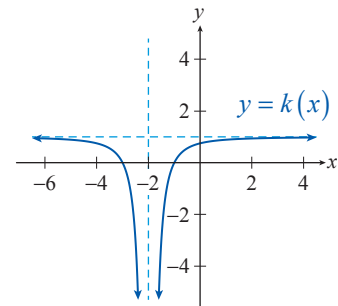

19.

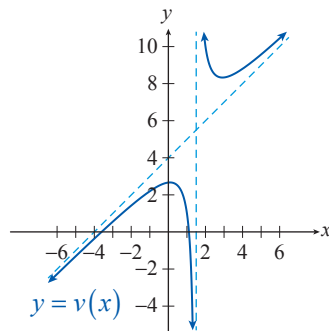

20.

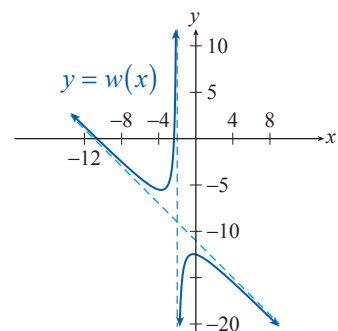

21.

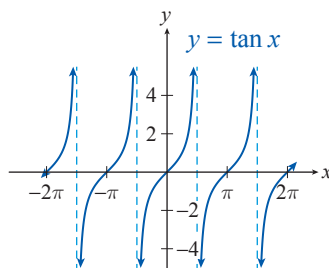

22.

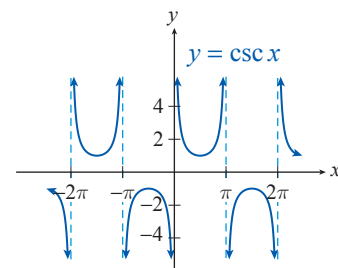

23.

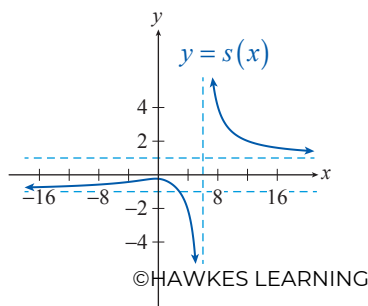

24.

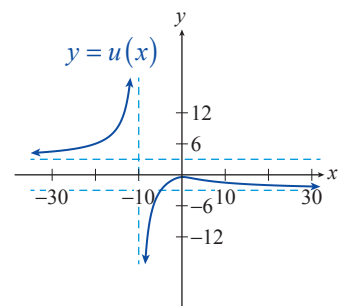

25–36. Consider the functions given in Exercises 13–24. Find their limits at  $\infty$  and  $-\infty$  (if they exist). When applicable, use the horizontal asymptote(s) as a guide.

Use the graph to find the indicated one-sided limits, if they exist.

37. a.  $\lim_{x \rightarrow 2^-} f(x)$       b.  $\lim_{x \rightarrow 2^+} f(x)$       38. a.  $\lim_{x \rightarrow 1^-} g(x)$       b.  $\lim_{x \rightarrow 1^+} g(x)$

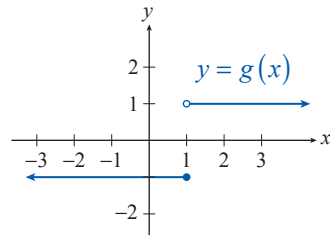
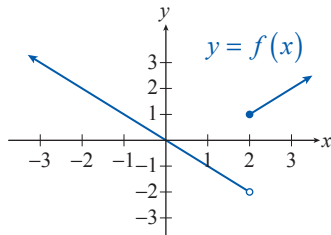

39. a.  $\lim_{x \rightarrow 1^-} h(x)$       b.  $\lim_{x \rightarrow 1^+} h(x)$       40. a.  $\lim_{x \rightarrow (\frac{\pi}{2})^-} F(x)$       b.  $\lim_{x \rightarrow (\frac{\pi}{2})^+} F(x)$

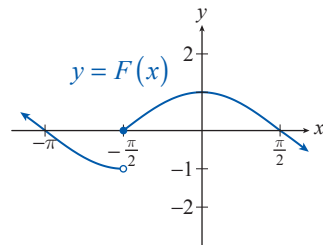
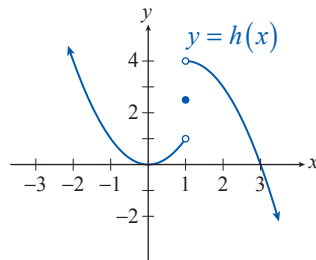

41. a.  $\lim_{x \rightarrow 0^-} G(x)$       b.  $\lim_{x \rightarrow 0^+} G(x)$       42. a.  $\lim_{x \rightarrow -1^-} k(x)$       b.  $\lim_{x \rightarrow -1^+} k(x)$

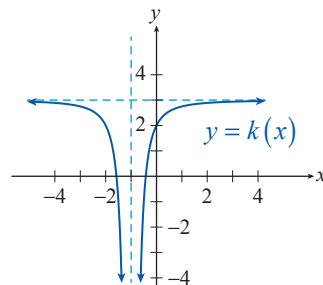
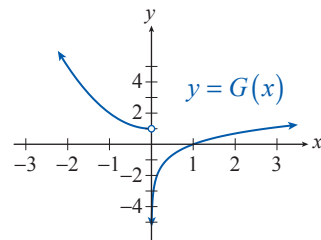

43. a.  $\lim_{x \rightarrow 0^-} H(x)$       b.  $\lim_{x \rightarrow 0^+} H(x)$       44. a.  $\lim_{x \rightarrow 2^-} u(x)$       b.  $\lim_{x \rightarrow 2^+} u(x)$

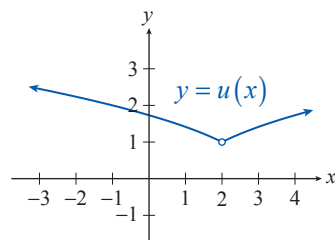
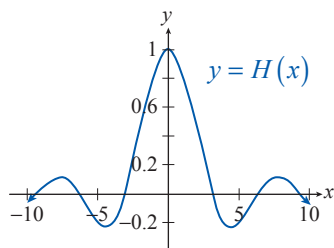

45. a.  $\lim_{x \rightarrow 0^-} v(x)$

b.  $\lim_{x \rightarrow 0^+} v(x)$

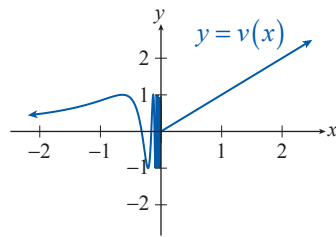

46. a.  $\lim_{x \rightarrow 0^-} w(x)$

b.  $\lim_{x \rightarrow 0^+} w(x)$

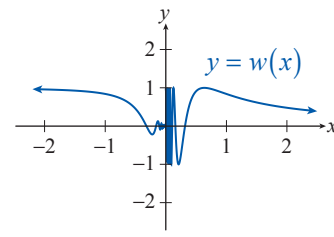

Use limit notation to describe the unbounded behavior of the given function as  $x$  approaches  $\infty$  and/or  $-\infty$ .

47.  $f(x) = x^3$

48.  $g(x) = x^2 + 2.1x - 1$

49.  $h(x) = -x^4 + 0.2x^3$

50.  $k(x) = -0.35x^5 + x + 1.35$

51.  $F(x) = \sqrt{x+2}$

52.  $G(x) = \sqrt[3]{x+1} - 2.3$

53.  $H(x) = |x+2|$

54.  $K(x) = -|x+2| - 1$

55.  $u(x) = |x-1| + |x+2|$

56.  $v(x) = e^{x+2}$

57.  $s(x) = -10^{-x} + 1$

58.  $t(x) = \ln x - 1$

### WRITING & THINKING

Determine whether the given statement is true or false. If false explain or provide a counterexample.

59. If  $\lim_{x \rightarrow c} f(x)$  does not exist, then  $f(x)$  is undefined at  $x = c$ .

60. If  $f(x)$  is undefined at  $x = c$ , then  $\lim_{x \rightarrow c} f(x)$  does not exist.

61. If  $f(x)$  is defined on  $(0, \infty)$  and  $y = 0$  is a horizontal asymptote for  $f(x)$ , then there exists a number  $M$  such that if  $x > M$  then  $f(x) < \frac{1}{10^6}$ .

62. If  $f(x)$  has a vertical asymptote at  $x = c$ , then either  $\lim_{x \rightarrow c} f(x) = \infty$  or  $\lim_{x \rightarrow c} f(x) = -\infty$ .

63. If  $\lim_{x \rightarrow c} f(x)$  does not exist, then  $\lim_{x \rightarrow c^-} f(x) \neq \lim_{x \rightarrow c^+} f(x)$  or at least one of  $\lim_{x \rightarrow c^-} f(x)$  or  $\lim_{x \rightarrow c^+} f(x)$  does not exist.

 TECHNOLOGY

Use a graphing utility to decide whether the given limit exists by evaluating the function at several  $x$ -values approaching the indicated  $c$ -value. Then graph the function to confirm your findings. Do you obtain misleading graphs when choosing small viewing windows?

$$64. \lim_{x \rightarrow 2} \frac{x^2 - 5x + 6}{x - 2}$$

$$65. \lim_{x \rightarrow 3} \frac{x - 2}{x^2 - 5x + 6}$$

$$66. \lim_{x \rightarrow -1.5} \frac{x^2 - 2.25}{x + 1.5}$$

$$67. \lim_{x \rightarrow 1} \frac{x - 1}{\sqrt{x} - 1}$$

$$68. \lim_{x \rightarrow 3} \frac{\sqrt{x+1} - 2}{x - 3}$$

$$69. \lim_{x \rightarrow 0} \frac{\sin(3x)}{2x}$$

$$70. \lim_{x \rightarrow 0^+} \cos\left(\frac{1}{x}\right)$$

$$71. \lim_{x \rightarrow 0^+} \left[ x \cos\left(\frac{1}{x}\right) \right]$$

72. Evaluate the function  $f(x) = \left(1 + \frac{1}{x}\right)^x$  for several consecutive positive integers, and try to observe a tendency. Then use a graphing utility to graph  $f(x)$  in a large viewing window and try to guess  $\lim_{x \rightarrow \infty} f(x)$ . Have you seen that number before?

### 13.3 EXERCISES

#### 💡 PRACTICE

Use the graph to estimate  $\delta$  corresponding to the given  $\varepsilon$  satisfying the  $\varepsilon$ - $\delta$  definition of  $\lim_{x \rightarrow c} f(x) = L$ . See Example 1.

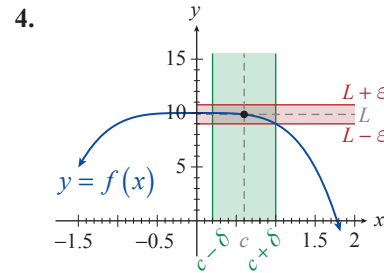
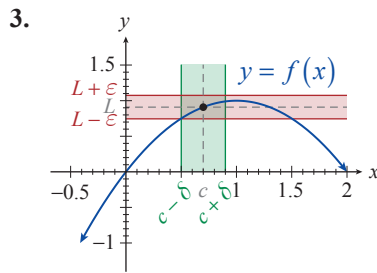
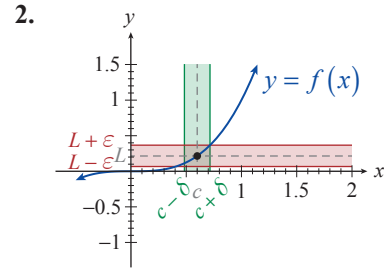
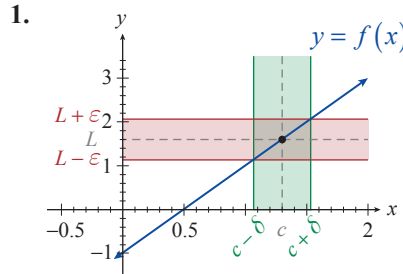

Find a  $\delta > 0$  that satisfies the limit claim corresponding to  $\varepsilon = 0.1$ ; that is, such that  $0 < |x - c| < \delta$  would imply  $|f(x) - L| < 0.1$ .

5.  $\lim_{x \rightarrow 2} (5x - 1) = 9$

6.  $\lim_{x \rightarrow 1} (3x + 1) = 4$

7.  $\lim_{x \rightarrow -1} (-x + 2) = 3$

8.  $\lim_{x \rightarrow 6} \left(4 - \frac{x}{2}\right) = 1$

9.  $\lim_{x \rightarrow 0} x^2 = 0$

10.  $\lim_{x \rightarrow 8} \sqrt[3]{x} = 2$

11.  $\lim_{x \rightarrow 1} \frac{1}{x} = 1$

12.  $\lim_{x \rightarrow 0} e^x = 1$

13.  $\lim_{x \rightarrow 1} \ln x = 0$

14.  $\lim_{x \rightarrow 0} \cos x = 1$

Find a number  $N$  that satisfies the limit claim corresponding to  $\varepsilon = 0.1$ ; that is, such that  $x > N$  (or  $x < N$ , as appropriate) would imply  $|f(x) - L| < 0.1$ .

15.  $\lim_{x \rightarrow \infty} \frac{1}{x} = 0$

16.  $\lim_{x \rightarrow \infty} \frac{x^2 - 1}{x^2 + 2x} = 1$

17.  $\lim_{x \rightarrow \infty} \frac{x + 1}{x} = 1$

18.  $\lim_{x \rightarrow \infty} \frac{2x}{\sqrt{x^2 + x}} = 2$

19.  $\lim_{x \rightarrow -\infty} e^x = 0$

20.  $\lim_{x \rightarrow \infty} \arctan x = \frac{\pi}{2}$

For the given function  $f(x)$ , find a  $\delta > 0$  corresponding to  $M = 100$ ; that is, such that  $0 < |x - c| < \delta$  would imply  $f(x) > 100$  (let  $N = -100$  if the limit is  $-\infty$ , in which case  $0 < |x - c| < \delta$  should imply  $f(x) < -100$ ).

21.  $\lim_{x \rightarrow 0} \frac{1}{x^2} = \infty$

22.  $\lim_{x \rightarrow 0^+} \frac{1}{x} = \infty$

23.  $\lim_{x \rightarrow -1} \frac{-1}{(x+1)^2} = -\infty$

24.  $\lim_{x \rightarrow 0^+} \ln x = -\infty$

25.  $\lim_{x \rightarrow \frac{\pi}{2}^-} \tan x = \infty$

26.  $\lim_{x \rightarrow 0^+} \csc x = \infty$

Use the  $\varepsilon$ - $\delta$  definition to prove the limit claim. See Examples 3 and 4.

27.  $\lim_{x \rightarrow 1} (2x + 3) = 5$

28.  $\lim_{x \rightarrow 7} x = 7$

29.  $\lim_{x \rightarrow c} a = a$

30.  $\lim_{x \rightarrow 4} \left( \frac{1}{4}x + 1 \right) = 2$

31.  $\lim_{x \rightarrow 0} \left( \frac{1}{2} - 4x \right) = \frac{1}{2}$

32.  $\lim_{x \rightarrow 9} \left( 5 - \frac{x}{3} \right) = 2$

33.  $\lim_{x \rightarrow 1} x^3 = 1$

34.  $\lim_{x \rightarrow 0} x^2 = 0$

35.  $\lim_{x \rightarrow 0} \left( \frac{1}{2}|x| \right) = 0$

36.  $\lim_{x \rightarrow -2} |x + 2| = 0$

37.  $\lim_{x \rightarrow 1^+} \sqrt{x-1} = 0$

38.  $\lim_{x \rightarrow 0^+} (\sqrt[3]{x} + 1) = 1$

39.  $\lim_{x \rightarrow 1} (x^2 + x) = 2$

40.  $\lim_{x \rightarrow 3} (3x^2 - 9x + 5) = 5$

Give the formal definition of the limit claim. Then use the definition to prove the claim. See Examples 5 and 6.

41.  $\lim_{x \rightarrow \infty} \frac{1+x}{x} = 1$

42.  $\lim_{x \rightarrow -\infty} \frac{2}{x^2} = 0$

43.  $\lim_{x \rightarrow \infty} \frac{1}{\sqrt{x}} = 0$

44.  $\lim_{x \rightarrow \infty} \frac{1+3x^3}{x^3} = 3$

45.  $\lim_{x \rightarrow -\infty} 2^x = 0$

46.  $\lim_{x \rightarrow \infty} (e^{-x} - 1) = -1$

47.  $\lim_{x \rightarrow \infty} \frac{\sin x}{x} = 0$

48.  $\lim_{x \rightarrow \infty} (2 \arctan x) = \pi$

49.  $\lim_{x \rightarrow \infty} \frac{1}{x} = 0$

50.  $\lim_{x \rightarrow 0} \frac{1}{x^4} = \infty$

51.  $\lim_{x \rightarrow -1} \frac{-1}{(x+1)^2} = -\infty$

52.  $\lim_{x \rightarrow 0^+} \log x = -\infty$

53.  $\lim_{x \rightarrow \frac{\pi}{2}^+} \tan x = -\infty$

54.  $\lim_{x \rightarrow 0^+} \csc x = \infty$

55.  $\lim_{x \rightarrow 2} \frac{-3}{(x-2)^2} = -\infty$

56.  $\lim_{x \rightarrow -2^-} \frac{x+3}{x+2} = -\infty$

Determine whether the limit exists. Prove your conclusion. See Example 7.

$$57. \lim_{x \rightarrow 0^+} \sin\left(\frac{\pi}{x}\right) \qquad 58. \lim_{x \rightarrow 0^+} \left(x^2 \cos\left(\frac{1}{x}\right)\right) \qquad 59. \lim_{x \rightarrow 0} \frac{|x|}{x}$$

$$60. \lim_{x \rightarrow 1} f(x), \text{ where } f(x) = \begin{cases} 1 & \text{if } x \text{ is rational} \\ 0 & \text{if } x \text{ is irrational} \end{cases}$$

$$61. \lim_{x \rightarrow 0} g(x), \text{ where } g(x) = \begin{cases} x & \text{if } x \text{ is rational} \\ 0 & \text{if } x \text{ is irrational} \end{cases}$$

### APPLICATIONS

62. A piston is manufactured to fit into the cylinder of a certain automobile engine. Suppose that the diameter of the cylinder is 82 mm and that the cross-sectional area of the piston is not allowed to be less than 99.89% of that of the cylinder. If both are perfectly round, what does this mean in terms of maximum tolerance for the clearance between the piston and the cylinder wall? (Be sure to identify which function and data take the roles of  $f(x)$ ,  $c$ ,  $\varepsilon$ , and  $\delta$  in this problem.)
63. The tension in a stretched steel wire (in newtons, N) is calculated by the formula  $F = E \frac{\Delta L}{L_0} A$ , where  $E = 2 \times 10^{11} \text{ N/m}^2$  is the elastic modulus (or Young's modulus) of steel,  $\Delta L$  is the elongation,  $L_0$  the original length, and  $A$  the cross-sectional area (in  $\text{m}^2$ ). Suppose a 1-meter-long steel string of radius 1 millimeter is stretched by 2 millimeters when tuning a musical instrument.
- Calculate the tension in the string caused by the above tightening.
  - If we are not allowed to overload the string by more than 100 N, what is the tolerance in the amount of stretching? (Be sure to identify the function and data taking the roles of  $c$ ,  $\varepsilon$ , and  $\delta$  in this problem.)

### WRITING & THINKING

64. Use  $\varepsilon$  and  $\delta$  to state what  $\lim_{x \rightarrow c} f(x) \neq L$  means.

Students gave the following definitions for the existence of a limit of  $f(x)$  at  $c$ . Find and correct any errors.

65. “ $\lim_{x \rightarrow c} f(x)$  exists if for any  $\varepsilon > 0$  and real number  $L$  there is a  $\delta > 0$  such that  $0 < |x - L| < \delta$  implies  $|f(x) - c| < \varepsilon$ .”
66. “ $\lim_{x \rightarrow c} f(x)$  exists and equals  $L$  if for any  $\varepsilon > 0$  and  $\delta > 0$  whenever  $0 < |x - c| < \varepsilon$ , we have  $|f(x) - L| < \delta$ .”
67. “If there is a real number  $L$  such that for an  $\varepsilon > 0$  there is a  $\delta > 0$  such that whenever  $|x - c| < \delta$  and  $x \neq c$ , we have  $|f(x) - L| < \varepsilon$ , we say that the limit of the function at  $c$  is  $L$ .”

68. “We say that  $\lim_{x \rightarrow c} f(x) = L$ , if for any  $\varepsilon > 0$  there is a  $\delta > 0$  such that  $|x - c| < \delta \Rightarrow |f(x) - L| < \varepsilon$ .”

69. “We say that  $\lim_{x \rightarrow c} f(x) = L$ , if for any  $\varepsilon > 0$  there is a  $\delta > 0$  such that  $0 \leq |x - c| \leq \delta \Rightarrow |f(x) - L| \leq \varepsilon$ .”

70. “If the real number  $L$  is such that for any  $\varepsilon > 0$  there is a  $\delta > 0$  such that  $0 < |x - c| < \delta \Rightarrow |f(x) - L| < \varepsilon$ , we say that  $\lim_{x \rightarrow c} f(x) = L$ .”

Determine whether the given statement is true or false. If false, explain or provide a counterexample.

71. If  $f(c) = L$ , then as  $x$  approaches  $c$ ,  $\lim_{x \rightarrow c} f(x) = L$ .

72. If  $\lim_{x \rightarrow c} f(x)$  exists and equals  $L$ , then  $f(c) = L$ .

73. If  $f(x) < g(x)$  for all  $x \neq c$ , and both  $\lim_{x \rightarrow c} f(x)$  and  $\lim_{x \rightarrow c} g(x)$  exist, then  $\lim_{x \rightarrow c} f(x) < \lim_{x \rightarrow c} g(x)$ .

### TECHNOLOGY

Use a graphing utility to estimate the given limit. By zooming in appropriately, find  $\delta$ -values that correspond to  $\varepsilon = 0.1$ .

74.  $\lim_{x \rightarrow 5} \frac{x^2 - 5x + 6}{x - 2}$

75.  $\lim_{x \rightarrow 0} \frac{\sqrt{x+5} - \sqrt{5}}{x}$

76.  $\lim_{x \rightarrow 3.5} \frac{x^2 - 6.25}{x + 2.5}$

77.  $\lim_{x \rightarrow 0} \frac{x-1}{\sqrt{x}-1}$

78.  $\lim_{x \rightarrow 0} \frac{\sin 3x}{2x}$

79.  $\lim_{x \rightarrow \infty} \frac{2x+3}{\sqrt{x^2+1}}$

80.  $\lim_{x \rightarrow \infty} \frac{\sqrt{9x^2+1}}{x-2}$

81.  $\lim_{x \rightarrow \infty} \frac{2x^2+1.5x-7}{\sqrt{x^4+1}}$

82.  $\lim_{x \rightarrow \infty} \left( \sqrt{x^2+3x+5} - \sqrt{x^2+2x+1} \right)$

83.  $\lim_{x \rightarrow \infty} \left( 1 + \frac{1}{x} \right)^x$

Use a graphing utility to locate a vertical asymptote of the given function. Then for such an asymptote  $x = c$  find an appropriate value  $\delta > 0$  such that  $|x - c| < \delta \Rightarrow |f(x)| > 10$ . (Answers will vary.)

84.  $f(x) = \frac{x^2 - 7}{x^3 + x + 1}$

85.  $f(x) = \frac{3x+1}{2x^4+x-5}$

86.  $f(x) = \ln \left( \frac{x^2}{x^2+1} \right)$

87.  $f(x) = \tan \left( \frac{1}{2}x + 3 \right)$

88.  $f(x) = \csc(2x+1)$

89.  $f(x) = \cot \left( \frac{1}{2} \cos x \right)$

## 13.4 EXERCISES

## PRACTICE

Use the graph to find the given limit. See Example 1.

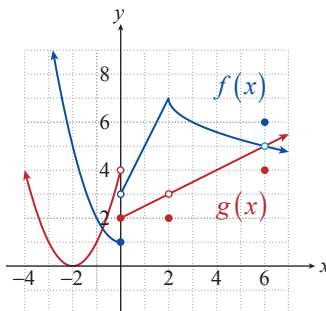

1. a.  $\lim_{x \rightarrow 0^+} [g(x) - 2f(x)]$                       b.  $\lim_{x \rightarrow 2^+} [g(x)f(x)]$
2. a.  $\lim_{x \rightarrow 6} [g(x) + f(x)]$                       b.  $\lim_{x \rightarrow 0^-} \frac{f(x)}{2g(x)}$

Use appropriate limit laws to evaluate the given limit. See Examples 3 and 4.

3.  $\lim_{x \rightarrow 4} 5$     4.  $\lim_{x \rightarrow 4} (5x)$
5.  $\lim_{x \rightarrow 3} (2x + 1)$                                   6.  $\lim_{x \rightarrow \frac{1}{2}} (3 - 4x)$
7.  $\lim_{x \rightarrow -3} x^2$                                       8.  $\lim_{x \rightarrow -2} (-x^5)$
9.  $\lim_{x \rightarrow 3} (2x^2 - x + 7)$                       10.  $\lim_{x \rightarrow -1} \left(3 + x - \frac{5}{2}x^2\right)$
11.  $\lim_{x \rightarrow \frac{1}{2}} (2x^3 - 3x^2 + x - 4)$               12.  $\lim_{x \rightarrow -2} (3x^3 - x^5)$
13.  $\lim_{x \rightarrow 1} \frac{3x - 7}{x + 1}$                                   14.  $\lim_{x \rightarrow -1} \frac{5x + 3}{x^2 - x}$
15.  $\lim_{x \rightarrow 3} \left(\frac{4x}{11x - x^3}\right)^{\frac{1}{3}}$                       16.  $\lim_{t \rightarrow 1} \left(\frac{2t + t^3}{3t^2 + 1}\right)^{\frac{3}{2}}$
17.  $\lim_{x \rightarrow -2} \sqrt[3]{5x^4 - x^3 + 3x^2 + 2x + 4}$       18.  $\lim_{x \rightarrow 4} \sqrt{x^4 + 2x^2 + 1}$
19.  $\lim_{x \rightarrow -3} \left(\frac{x^4 - 5x}{x^3 + 2x^2 - 4x}\right)^{\frac{4}{5}}$       20.  $\lim_{x \rightarrow -5} \sqrt[3]{(x^4 + 2x^3 + x^2)^2}$

Use algebra to evaluate the given limit. See Examples 5, 6, and 7.

21.  $\lim_{x \rightarrow 6} \frac{x^2 - 36}{x - 6}$                                       22.  $\lim_{x \rightarrow -7} \frac{x + 7}{x^2 - 49}$

23. 
$$\lim_{x \rightarrow 3} \frac{3 - 13x + 4x^2}{x - 3}$$

25. 
$$\lim_{x \rightarrow 5} \frac{2x^3 - 7x^2 - 14x - 5}{x^2 - 25}$$

27. 
$$\lim_{x \rightarrow 7} \frac{\sqrt{x+2} - 3}{x - 7}$$

29. 
$$\lim_{x \rightarrow 0} \frac{\sqrt{x+5} - \sqrt{5}}{x}$$

31. 
$$\lim_{x \rightarrow 2} \frac{\frac{1}{3} - \frac{1}{1+x}}{x - 2}$$

32. If  $f(x) = x^2$ , find  $\lim_{x \rightarrow 2} \frac{f(x) - f(2)}{x - 2}$ .

33. If  $g(x) = x^2 - 2$ , find  $\lim_{h \rightarrow 0} \frac{g(3+h) - g(3)}{h}$ .

34. If  $k(x) = 1 - x + x^2$ , find  $\lim_{h \rightarrow 0} \frac{k(2-h) - k(2)}{h}$ .

35. If  $p(x) = x^3 + x$ , find  $\lim_{x \rightarrow 1} \frac{p(x) - p(1)}{x - 1}$ .

36. If  $F(x) = \frac{1}{x}$ , find  $\lim_{x \rightarrow \frac{1}{2}} \frac{F(x) - F\left(\frac{1}{2}\right)}{x - \frac{1}{2}}$ .

37. 
$$\lim_{h \rightarrow 0} \frac{\sqrt{x+h} - \sqrt{x}}{h}$$

39. 
$$\lim_{x \rightarrow 2} \frac{x^4 - 16}{3x^2 - 5x - 2}$$

41. 
$$\lim_{x \rightarrow 2} \frac{3 - \sqrt{x+7}}{x - 2}$$

43. 
$$\lim_{y \rightarrow 0} \left( \frac{1}{y} + \frac{1}{y^2 - y} \right)$$

24. 
$$\lim_{x \rightarrow 4} \frac{x^4 - 256}{x^2 - 16}$$

26. 
$$\lim_{x \rightarrow 2} \frac{x^3 - 8}{x^3 - 2x^2 + 2x - 4}$$

28. 
$$\lim_{x \rightarrow 9} \frac{3 - \sqrt{x}}{x - 9}$$

30. 
$$\lim_{x \rightarrow 0} \frac{\frac{1}{4+x} - \frac{1}{4}}{x}$$

38. 
$$\lim_{x \rightarrow 3} \frac{2x^2 - 3x - 9}{x^2 - 9}$$

40. 
$$\lim_{x \rightarrow -3} \frac{\frac{1}{3} + \frac{1}{x}}{x^3 + 27}$$

42. 
$$\lim_{x \rightarrow 8} \frac{8 - x}{\sqrt[3]{x} - 2}$$

44. 
$$\lim_{x \rightarrow 1} \frac{\sqrt{x} - 1}{\sqrt[3]{x} - 1}$$

Use  $\lim_{x \rightarrow c} f(x) = 3$  and  $\lim_{x \rightarrow c} g(x) = -2$  to find the limit.

45. 
$$\lim_{x \rightarrow c} [2f(x) - g(x)]$$

47. 
$$\lim_{x \rightarrow c} \sqrt{[f(x)]^4 + 10[g(x)]^2}$$

49. 
$$\lim_{x \rightarrow c} ([f(x)]^2 + (x-2)g(x))$$

46. 
$$\lim_{x \rightarrow c} \frac{4f(x) + 3g(x)}{f(x) - \frac{1}{2}g(x)}$$

48. 
$$\lim_{x \rightarrow c} ([f(x) - 1]^2 \sqrt[3]{g(x)})$$

50. 
$$\lim_{x \rightarrow c} \left( \frac{f(x) + g(x)}{[g(x)]^2} \right)^{\frac{3}{2}}$$

Use the limit laws to find the one-sided limit.

$$51. \lim_{x \rightarrow 0^+} \frac{x}{|x|}$$

$$52. \lim_{x \rightarrow 0^-} (\operatorname{sgn} x \cos x), \text{ where } \operatorname{sgn} x = \begin{cases} 1 & \text{if } x > 0 \\ 0 & \text{if } x = 0 \\ -1 & \text{if } x < 0 \end{cases}$$

$$53. \lim_{x \rightarrow 2^+} \frac{\sqrt{x-2}}{3x+1}$$

$$54. \lim_{x \rightarrow 1^-} \sqrt{1-x^2}$$

$$55. \lim_{x \rightarrow \left(\frac{1}{3}\right)^-} \frac{\sqrt{1-3x}}{6x+5}$$

$$56. \lim_{x \rightarrow 1^+} (\lfloor x \rfloor - x) \text{ (See the definition of } f(x) = \lfloor x \rfloor \text{ in Section 3.4.)}$$

$$57. \lim_{x \rightarrow 2^+} (\lfloor x \rfloor e^x) \qquad 58. \lim_{x \rightarrow -1^-} \frac{\lfloor x \rfloor (2x^2 + 1)}{x + 3}$$

Use the Squeeze Theorem to prove the limit claim. See Example 8.

$$59. \lim_{x \rightarrow 0} \left( x^2 \sin \left( \frac{1}{x} \right) \right) = 0$$

$$60. \lim_{x \rightarrow 0} (|x| \cos x) = 0$$

$$61. \lim_{x \rightarrow \infty} \frac{\cos x}{x} = 0$$

$$62. \lim_{x \rightarrow -\infty} (e^x \sin x) = 0$$

$$63. \lim_{x \rightarrow 0^+} \left( x^{\frac{3}{2}} e^{\cos \left( \frac{1}{x} \right)} \right) = 0$$

$$64. \lim_{x \rightarrow \infty} \frac{\sin^2 x + 1}{2 + x} = 0$$



### WRITING & THINKING

65. Provide a rigorous proof of the limit claim  $\lim_{x \rightarrow c} 1 = 1$ . (**Hint:** Use the fact that for the constant 1 function,  $f(x) = 1$  for all  $x$ , so in particular, if an  $\varepsilon > 0$  is given,  $|f(x) - 1| = |1 - 1| = 0$ , which makes the choice of  $\delta$  “easy.”)
66. Provide a rigorous proof of the limit claim  $\lim_{x \rightarrow c} x = c$ . (**Hint:** Since  $f(x) = x$  in this problem, for a given  $\varepsilon > 0$  we need to ensure that  $|f(x) - c| = |x - c| < \varepsilon$  as long as  $0 < |x - c| < \delta$ . This observation makes the choice of  $\delta$  obvious.)
67. Use Exercise 66 and the basic limit laws to prove the Polynomial Substitution Law. (**Hint:** From Exercise 66 and a repeated application of the Product Law it follows that  $\lim_{x \rightarrow c} x^k = c^k$ . As a next step, from the Constant Multiple Law we can conclude that if  $a \in \mathbb{R}$ ,  $\lim_{x \rightarrow c} (ax^k) = ac^k$ . From the above claim, a repeated application of the Sum Law will yield the result for a general polynomial.)
68. Use Exercise 67 and the basic limit laws to prove the Rational Function Substitution Law.

69. Combine the Positive Integer Power Law and the Positive Integer Root Law to prove the Rational Power Law. (**Hint:** Assuming first that both  $m$  and  $n$  are positive, we can write  $\lim_{x \rightarrow c} [f(x)]^{\frac{m}{n}} = \lim_{x \rightarrow c} \left[ [f(x)]^{\frac{1}{n}} \right]^m = \lim_{x \rightarrow c} \left[ \sqrt[n]{f(x)} \right]^m$ . Now use the Positive Integer Power Law followed by the Positive Integer Root Law to obtain that the above limit is equal to  $\left[ \lim_{x \rightarrow c} \sqrt[n]{f(x)} \right]^m = \left[ \sqrt[n]{\lim_{x \rightarrow c} f(x)} \right]^m$ , from which the result follows. If  $m$  is negative, note that  $[f(x)]^{\frac{m}{n}} = \frac{1}{[f(x)]^{-\frac{m}{n}}}$ , where  $-m$  is positive. Thus if we use the Quotient Law along with the previous argument, we obtain

$$\begin{aligned} \lim_{x \rightarrow c} [f(x)]^{\frac{m}{n}} &= \lim_{x \rightarrow c} \frac{1}{[f(x)]^{-\frac{m}{n}}} \\ &= \frac{1}{\lim_{x \rightarrow c} [f(x)]^{\frac{m}{n}}} \\ &= \frac{1}{\left[ \lim_{x \rightarrow c} f(x) \right]^{\frac{m}{n}}} \end{aligned}$$

from which the result easily follows.)

70. Let  $D(x) = \begin{cases} 0 & \text{if } x \text{ is rational} \\ 1 & \text{if } x \text{ is irrational} \end{cases}$ . Does  $\lim_{x \rightarrow 0} D(x)$  exist? Prove your answer.
71. Let  $F(x) = \begin{cases} 0 & \text{if } x \text{ is rational} \\ x^2 & \text{if } x \text{ is irrational} \end{cases}$ . Does  $\lim_{x \rightarrow 0} F(x)$  exist? Prove your answer.
72. Prove that if  $\lim_{x \rightarrow c} f(x) = L$  and  $\lim_{x \rightarrow c} f(x) = K$ , then  $L = K$ . In words, prove that if the limit of  $f$  exists at  $c$ , then the limit is unique.
73. Prove that if  $n$  and  $m$  are positive integers, then  $\lim_{x \rightarrow 1} \frac{x^n - 1}{x^m - 1} = \frac{n}{m}$ .
74. Prove that if  $\lim_{x \rightarrow c} f(x) = 0$ , then  $\lim_{x \rightarrow c} |f(x)| = 0$ .
75. Prove that if  $\lim_{x \rightarrow c} f(x) = 0$  and  $g(x)$  is such that  $|g(x)| \leq M$  for some number  $M$  (such functions are called bounded), then  $\lim_{x \rightarrow c} [f(x)g(x)] = 0$ .
76. Prove that in Exercise 75, it is sufficient to require the boundedness of  $g$  only on an interval around  $c$  (except at  $c$  itself).
77. By finding functions  $f$  and  $g$  such that  $\lim_{x \rightarrow c} f(x) = 0$  but  $\lim_{x \rightarrow c} [f(x)g(x)] \neq 0$ , show that it is necessary to impose a boundedness condition on  $g$  in Exercise 75.

78. Give examples of  $f$  and  $g$  to show that

- the existence of  $\lim_{x \rightarrow c} [f(x) + g(x)]$  does not imply the existence of  $\lim_{x \rightarrow c} f(x)$ , and
- the existence of  $\lim_{x \rightarrow c} [f(x)g(x)]$  does not imply the existence of  $\lim_{x \rightarrow c} f(x)$ .

### 🔗 APPLICATIONS

79. A *concave spherical mirror* is a part of the inside of a sphere, silvered to form a reflective surface. The radius  $r$  of the sphere is called the mirror's *radius of curvature*. If the size of such a mirror is small relative to its radius of curvature, light rays parallel to its principal axis are reflected through approximately a single point, called *focus*. In the following illustration,  $C$  denotes the center,  $F_d$  is the focus, while  $d$  is the distance between the incoming ray and the principal axis. Note that according to the Law of Reflection, the incoming and reflected rays make the same size angle  $\alpha$  with the radius  $\overline{CR}$  (this radius is called *normal* to the mirror surface). One way to determine the *focal length* (the distance between the mirror and the focus) is to find the limiting position of  $F_d$  as  $d \rightarrow 0$ . Noting that the triangle  $\triangle CRF_d$  is isosceles, by similarity we obtain  $\frac{CF_d}{\frac{r}{2}} = \frac{r}{\sqrt{r^2 - d^2}}$ . Use this

observation to express  $CF_d$  and determine the focal length of the spherical mirror by taking the limit as  $d \rightarrow 0$ .

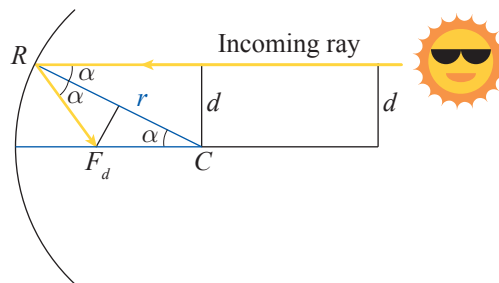

**NOTE**

The Intermediate Value Theorem is an *existence theorem*; in other words, we proved the *existence* of a solution between 0 and 1 without actually specifying what it is.

In other words, a change of sign occurs on  $[0,1]$ ; that is,  $f$  goes from negative to positive on  $[0,1]$ . The statement of the Intermediate Value Theorem is precisely the fact that a continuous function cannot do this and avoid intersecting the horizontal line  $y = 0$  (the  $x$ -axis). More precisely, since  $L = 0$  we have  $-4 < L < 6$ ; that is, since 0 is a real number between  $f(0) = -4$  and  $f(1) = 6$ , by the Intermediate Value Theorem there is a  $c$  in  $[0,1]$  such that  $f(c) = L = 0$ . In other words, we have

$$c^5 + 9c - 4 = 0.$$

Thus we proved the existence of a root between 0 and 1 for the given equation.

**13.5 EXERCISES****PRACTICE**

Find all points of continuity as well as all points of discontinuity for the given function. For any discontinuities, identify those from the three continuity criteria that fail to hold. See Examples 1 and 2.

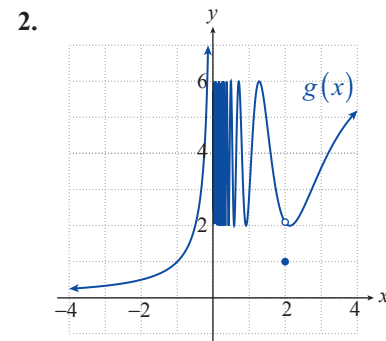
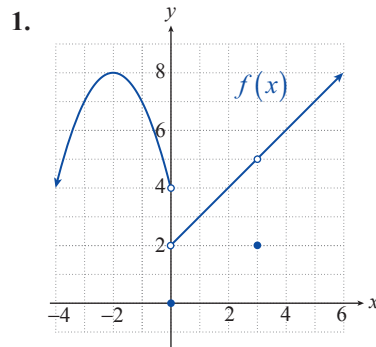

- Sketch a graph of a function (a formula is not necessary) that has a removable discontinuity at  $x = -1$ , a jump discontinuity at  $x = 2$ , but is right-continuous at  $x = 2$ .
- Sketch a graph of a function that has an infinite discontinuity at  $x = 0$  and an oscillating discontinuity at  $x = 5$  so that it is still left-continuous at  $x = 5$ .

Find and classify the discontinuities (if any) of the function as removable or nonremovable. See Example 3.

5.  $f(x) = \frac{1}{x}$

6.  $g(x) = \frac{-2}{x-3}$

7.  $h(x) = \frac{x^2 - 9}{x - 3}$

8.  $k(x) = \frac{x^2 - 2x}{x^2 + 5x - 14}$

9.  $u(x) = \frac{x^2 - 9}{x - 2}$

10.  $v(x) = \frac{x - 1}{x^2 + 2x - 3}$

$$11. w(x) = \begin{cases} x+1 & \text{if } x \leq 0 \\ \frac{1}{2}x^2 + 1 & \text{if } x > 0 \end{cases}$$

$$13. g(x) = \begin{cases} \tan x & \text{if } x < \frac{\pi}{2} \\ \cos x & \text{if } x \geq \frac{\pi}{2} \end{cases}$$

$$15. F(u) = \frac{u-4}{\sqrt{u-2}}, \quad u \geq 0$$

$$17. H(t) = \frac{t}{\sqrt{t^2+2}}$$

$$19. v(t) = |\sin t|$$

$$21. F(t) = \frac{t}{t^2-1}$$

$$23. H(x) = |x+2|$$

$$25. s(x) = \llbracket x+2 \rrbracket$$

$$27. u(z) = \llbracket z^2 \rrbracket$$

$$29. w(x) = x \llbracket \frac{1}{x} \rrbracket$$

$$12. f(x) = \begin{cases} \frac{1}{2}x-2 & \text{if } x \leq 4 \\ x^3+1 & \text{if } x > 4 \end{cases}$$

$$14. h(x) = \begin{cases} \cos x & \text{if } x \leq 0 \\ \tan x + 1 & \text{if } x > 0 \end{cases}$$

$$16. G(s) = \frac{s}{\sqrt{s+4}-2}, \quad s \geq -4$$

$$18. u(x) = \cos\left(\frac{1-x^2}{1-x}\right)$$

$$20. K(x) = |x+2| + |x-1|$$

$$22. G(t) = \frac{t}{t^2+1}$$

$$24. k(x) = \frac{|x-4|}{x-4}$$

$$26. t(x) = 4 - \llbracket x \rrbracket$$

$$28. v(x) = x \llbracket x \rrbracket$$

Use the  $\varepsilon$ - $\delta$  definition to prove that the function is continuous. See Example 5.

$$30. f(x) = \frac{1}{x}$$

$$31. g(x) = 3x-2$$

$$32. F(x) = x^3$$

$$33. G(x) = \sqrt{x}$$

Use the theorems of this section to describe the continuity of the function. See Example 7.

$$34. F(x) = \sqrt{\frac{x}{x^2+7x+12}}$$

$$35. G(x) = \sqrt{\frac{x^4-x^3-11x^2+9x+18}{2x^3+x}}$$

$$36. H(x) = \cos\left(\frac{2\ln(x-3)+1}{\sqrt[3]{x^2-2x-15}}\right)$$

$$37. f(x) = \arctan\left(\frac{x}{\sqrt{3-x^2}}\right)$$

$$38. g(x) = \ln(\arcsin(\pi x+1))$$

$$39. h(x) = \frac{\csc(\pi x+1)}{\sin(\pi e^{x+2})}$$

Use the alternate formulation of continuity to prove that the function is continuous. See Example 8.

$$40. f(x) = 3x-5x^2$$

$$41. g(x) = \cos x$$

$$42. h(x) = \tan x$$

$$43. k(x) = e^x$$

Identify the removable discontinuities and define the continuous extension of the function. See Example 10.

$$44. f(x) = \frac{x^2 + x - 12}{x - 3}$$

$$45. g(x) = \frac{x^3 - 2x^2 - x + 2}{x^2 - 3x + 2}$$

$$46. h(x) = \frac{x-1}{\sqrt{x}-1}$$

$$47. F(x) = \frac{\sqrt{x+1}-2}{x-3}$$

$$48. G(x) = 2 - \frac{1}{x^2}$$

$$49. H(x) = x \cos\left(\frac{\pi}{x}\right)$$

Describe the continuity of the function on the given closed interval.

$$50. S(x) = \sqrt{16-x^2} \text{ on } [-4, 4]$$

$$51. T(x) = \left\lfloor \frac{x}{3} \right\rfloor \text{ on } [0, 3]$$

$$52. U(x) = \begin{cases} \frac{1}{x^2-9} & \text{if } |x| < 3 \\ 0 & \text{if } |x| = 3 \end{cases} \text{ on } [-3, 3]$$

$$53. V(x) = \begin{cases} x^2 \sin\left(\frac{1}{x}\right) & \text{if } x \neq 0 \\ 0 & \text{if } x = 0 \end{cases} \text{ on } \left[0, \frac{1}{\pi}\right]$$

Find the value of  $a$  (or the values of  $a$  and  $b$ , where applicable) such that  $f$  is continuous on the entire real line.

$$54. f(x) = \begin{cases} 0 & \text{if } x \leq 0 \\ ax & \text{if } 0 < x < 1 \\ 2x+3 & \text{if } x \geq 1 \end{cases}$$

$$55. f(x) = \begin{cases} x^3 & \text{if } x \leq 3 \\ ax^2 & \text{if } x > 3 \end{cases}$$

$$56. f(x) = \begin{cases} -x^2 & \text{if } x < 1 \\ ax+b & \text{if } 1 \leq x \leq 3 \\ (x-3)^2 + 2 & \text{if } x > 3 \end{cases}$$

$$57. f(x) = \begin{cases} \cos x & \text{if } x \leq 0 \\ -(x-a)^2 + b & \text{if } 0 < x < 2 \\ \frac{1}{2}x - 2 & \text{if } x \geq 2 \end{cases}$$

Decide whether the Intermediate Value Theorem applies to the given function on the indicated interval. If so, find  $c$  as guaranteed by the theorem. If not, find the reason. See Example 11.

$$58. f(x) = -x^2 + x + 3 \text{ on } [0, 3]; \quad f(c) = 1$$

$$59. g(x) = 2x^3 - x^2 - 1 \text{ on } [-1, 2]; \quad g(c) = 0$$

$$60. h(x) = \frac{x}{x+2} \text{ on } [0, 4]; \quad h(c) = \frac{1}{2}$$

$$61. F(x) = \frac{2x}{x-1} \text{ on } [0, 2]; \quad F(c) = 2$$

$$62. G(x) = \lfloor x-2 \rfloor \text{ on } [-2, 2]; \quad G(c) = -\frac{1}{2}$$

$$63. H(x) = \sin\left(\frac{3x+2}{2}\right) \text{ on } \left[-\frac{2}{3}, \frac{\pi-2}{3}\right]; \quad H(c) = \frac{1}{2}$$

Use the Intermediate Value Theorem to prove that the given equation has a solution on the indicated interval. See Example 11.

64.  $x^3 - 7.5x^2 + 1.2x + 1 = 0$  on  $[-1, 0]$

65.  $2x^3 + x + 10 = 0$  on  $[-2, 1]$

66.  $\cos x = x^2$  on  $[0, \pi]$

67.  $\ln x - \sqrt{x-2} = 0$  on  $[2, 5]$

68.  $\frac{5}{x^2 + 2} = 1$  on  $[-3, -1]$

69.  $\cot\left(\frac{\pi x}{4}\right) - \frac{x}{x+2} = -\frac{1}{2}$  on  $[1, 3]$

### APPLICATIONS

70. Suppose that the outside temperature in Columbia, SC on a summer morning at 7:00 a.m. is 74 °F, and it shoots up to 98 °F by 1:00 p.m. Assuming that temperature changes continuously, prove that sometime between 7:00 a.m. and 1:00 p.m. the temperature was exactly 88.35 °F.

71. A hermit leaves his hut at the foot of a mountain one day at 6:00 a.m. and sets out to climb all the way to the top. He arrives at 6:00 p.m. and realizes that it is too late to go back, so he sets up camp for the night. At 6:00 a.m. the following day, he starts hiking back to his hut, taking the exact same route as the day before. This time, however, it is mostly downhill, so he makes much better time and arrives home at 2:00 p.m. Prove that there is a point along the hermit's route that he passed at exactly the same time on both days. (**Hint:** Apply the Intermediate Value Theorem or the Fixed Point Theorem. See Exercise 83.)

72. A long-distance phone company charges 31 cents for the first minute and 10 cents for each additional minute or any fraction thereof. Graph the cost as a function of time, find a formula for it, and describe the significance of its discontinuities. (**Hint:** Use the greatest integer function to construct your answer.)

73. If  $\Delta t$  denotes the length of the time interval between two events as measured by an observer on a spaceship moving at speed  $v$ , and  $\Delta T$  is the length of the same time interval as measured from Earth, then the formula relating the two quantities is given by

$$\Delta T = \frac{\Delta t}{\sqrt{1 - \frac{v^2}{c^2}}},$$

where  $c$  is the speed of light. This phenomenon is called *time dilation*, and it follows from the theory of relativity. In essence, it says that a clock moving at speed  $v$  relative to an observer is perceived by the same observer to run slower.

- Explain why we don't normally notice the time dilation effect in everyday life.
- What is the significance of the discontinuity of  $\Delta T$  (as a function of  $v$ )?

### WRITING & THINKING

74. Prove the alternate formulation of continuity; that is, the statement that a function  $f$  is continuous at the point  $c$  if and only if  $\lim_{h \rightarrow 0} f(c+h) = f(c)$ .

75. Prove that if  $f(x)$  is continuous and  $f(c) > 0$ , then there is a  $\delta > 0$  such that  $f(x) > 0$  for all  $x \neq c$  in the interval  $(c - \delta, c + \delta)$ .

76. Prove that the Dirichlet function  $\xi(x) = \begin{cases} 0 & \text{if } x \text{ is rational} \\ 1 & \text{if } x \text{ is irrational} \end{cases}$  is discontinuous at every real number.

77. Prove that the function  $f(x) = \begin{cases} 0 & \text{if } x \text{ is rational} \\ x^2 & \text{if } x \text{ is irrational} \end{cases}$  is continuous only at the single point  $c = 0$ .

78. Prove that if the functions  $f$  and  $g$  are both continuous on  $\mathbb{R}$  and they agree on the rationals (i.e.,  $f(x) = g(x)$  for all  $x \in \mathbb{Q}$ ), then  $f = g$ .

79. Prove that if  $f$  is continuous and never 0 on the interval  $[a, b]$ , then either  $f(x) > 0$  for every  $x$  in  $[a, b]$ , or  $f(x) < 0$  for every  $x$  in  $[a, b]$ .

80. (Existence of  $n^{\text{th}}$  roots) Prove that if  $b$  is a positive real number and  $n$  a positive integer, then there is a positive real number  $c$  such that  $c^n = b$ . (**Hint:** Consider the continuous function  $f(x) = x^n$  on the interval  $[0, b+1]$ .)

81. Prove that a circle of diameter  $d$  has a chord of length  $c$  for every number  $c$  between 0 and  $d$ .

82. Use the function

$$f(x) = \begin{cases} \sin\left(\frac{\pi}{x}\right) & \text{if } x \neq 0 \\ 0 & \text{if } x = 0 \end{cases}$$

to prove that the converse of the Intermediate Value Theorem is false; in other words, a function may possess the Intermediate Value Property without being continuous.

83. (Fixed Point Theorem) Prove that if the function  $f : [a, b] \rightarrow [a, b]$  is continuous, then there is a number  $c$  in  $[a, b]$  with  $f(c) = c$  (i.e.,  $c$  is “fixed,” or “not being moved,” by  $f$ ).

Determine whether the given statement is true or false. If false, explain or provide a counterexample.

84. If  $f$  is both left- and right-continuous at  $c$ , then  $f$  is continuous at  $c$ .

85. Any function  $f$  has an interval  $(a, b)$  on which it is continuous.

86. If  $c$  is a discontinuity of  $f$ , but  $f$  does not have a vertical asymptote at  $c$ , then  $c$  is a removable or jump discontinuity.

87. If  $\lim_{x \rightarrow c} f(x) = L$ , and  $f(c) = L$ , then  $f$  is continuous at  $c$ .

88. If  $c$  is a discontinuity of  $f$ , but  $\lim_{x \rightarrow c} f(x)$  exists, then  $c$  is a removable or jump discontinuity.

### TECHNOLOGY

89–94. Use a graphing utility to solve the equations given in Exercises 64–69 to four decimal places.

95–100. Use a graphing utility to graph the functions of Exercises 34–39 and explain how the graphs support your discussions of continuity in these exercises.

## 13.6 EXERCISES

 PRACTICE

Use the graph to estimate the derivative at the given points.

1. a.  $x_1 = -1$

b.  $x_2 = 1$

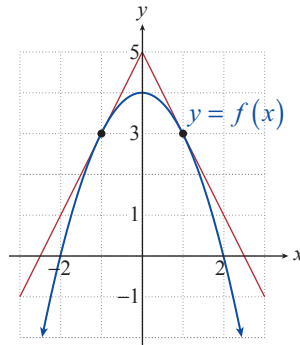

2. a.  $x_1 = -2$

b.  $x_2 = 0$

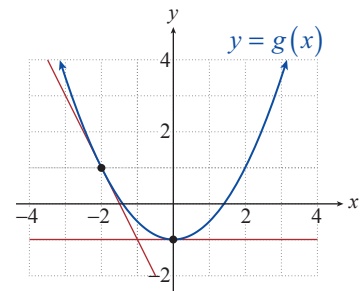

Find the equation of the tangent line to the graph of  $f(x)$  at the given point. See Example 1.

3.  $f(x) = x^2 - 2$ ;  $(2, 2)$

4.  $f(x) = 3x - 2x^2$ ;  $(-1, -5)$

5.  $f(x) = \frac{1}{2}x + 4$ ;  $(2, 5)$

6.  $f(x) = 1 - 5x$ ;  $(0, 1)$

7.  $f(x) = x^3$ ;  $(2, 8)$

8.  $f(x) = 5x - 2x^3$ ;  $(-1, -3)$

9.  $f(x) = \sqrt{x+1}$ ;  $(0, 1)$

10.  $f(x) = 2\sqrt{1-3x}$ ;  $(-1, 4)$

11.  $f(x) = \frac{1}{x}$ ;  $\left(\frac{1}{2}, 2\right)$

12.  $f(x) = \frac{5}{1-2x}$ ;  $\left(-1, \frac{5}{3}\right)$

13.  $f(x) = \frac{1}{\sqrt{x}}$ ;  $\left(4, \frac{1}{2}\right)$

14.  $f(x) = \frac{2}{\sqrt{x+1}}$ ;  $(3, 1)$

Use the definition (also called the *limit process*) to find the derivative function  $f'$  of the given function  $f$ . Find all  $x$ -values (if any) where the tangent line is horizontal. See Example 5.

15.  $f(x) = 2$

16.  $f(x) = 2x$

17.  $f(x) = 4x + 5$

18.  $f(x) = 3 - \frac{2}{5}x$

19.  $f(x) = 3x^2$

20.  $f(x) = 4 - 2x^2$

21.  $f(x) = \frac{1}{2}x^2 + 5x - 7$

22.  $f(x) = x - \frac{1}{3}x^2$

23.  $f(x) = x^3 + x$

24.  $f(x) = 7 + x - 3x^2 + x^3$

25.  $f(x) = x^4$

26.  $f(x) = \frac{1}{2x}$

27.  $f(x) = \frac{5}{2x-4}$

28.  $f(x) = \frac{x-2}{x+2}$

29.  $f(x) = \frac{2x+1}{x-3}$

31.  $f(x) = \frac{1}{x^2+1}$

33.  $f(x) = \sqrt{5x}$

35.  $f(x) = \sqrt{2x+1}$

37.  $f(x) = \sqrt{x^2+1}$

30.  $f(x) = \frac{2}{x^2}$

32.  $f(x) = \frac{2}{x^2-2x}$

34.  $f(x) = \frac{1}{\sqrt{5x}}$

36.  $f(x) = \frac{1}{\sqrt{x-2}}$

38.  $f(x) = \frac{1}{\sqrt{x^2+1}}$

Find the equation of a tangent line to the graph of the function that is parallel to the given line.

39.  $f(x) = x^2 + 3$ ;  $y - 6x + 1 = 0$

40.  $g(x) = 2x - x^2$ ;  $y - 5 = 4x$

41.  $h(x) = \frac{1}{2x}$ ;  $x + 2y = 3$

42.  $F(x) = \frac{1}{x-3}$ ;  $y + 4x + 7 = 0$

43.  $G(x) = \frac{1}{\sqrt{x}}$ ;  $54y + x = 1$

44.  $H(x) = \frac{1}{\sqrt{x^2-7}}$ ;  $27y + 4x - 2 = 0$

Use the alternate form of the definition of the derivative  $f'(c) = \lim_{x \rightarrow c} \frac{f(x) - f(c)}{x - c}$  to evaluate the given slope.

45.  $f(x) = 5 - \frac{1}{4}x$ ;  $f'(3.6)$

46.  $g(x) = x^2 + 1$ ;  $g'(-1)$

47.  $h(x) = (x+2)^2$ ;  $h'(3)$

48.  $F(t) = \frac{1}{t-3}$ ;  $F'(2)$

49.  $G(x) = \frac{2}{5-x}$ ;  $G'(7)$

50.  $k(t) = \sqrt{t+5}$ ;  $k'(11)$

51.  $u(x) = 2\sqrt{1-x}$ ;  $u'(-3)$

52.  $v(x) = \frac{1}{x^2+1}$ ;  $v'(0)$

53.  $w(s) = \frac{1}{\sqrt{s+4}}$ ;  $w'(5)$

54.  $F(t) = t^3 - t$ ;  $F'(1)$

55.  $G(s) = s^4$ ;  $G'(-2)$

56.  $H(x) = \frac{2}{\sqrt{x^2+1}}$ ;  $H'(0)$

Match the graph of  $f$  with the graph of its derivative  $f'$  (labeled a–d).

57.

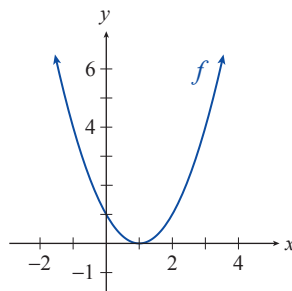

58.

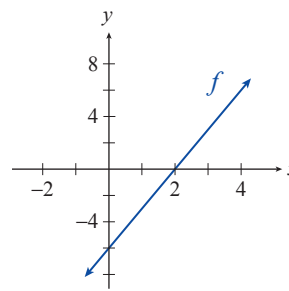

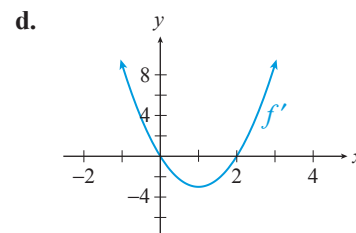
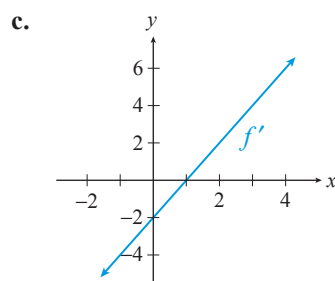
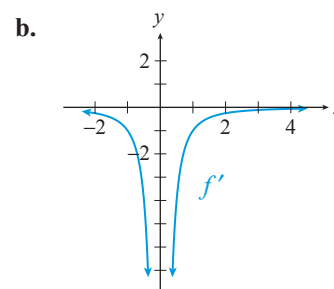
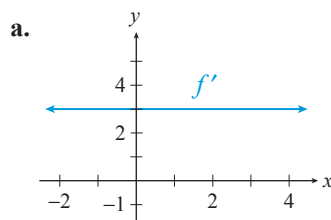
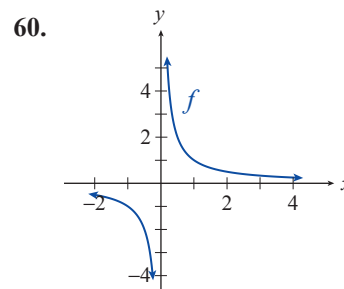
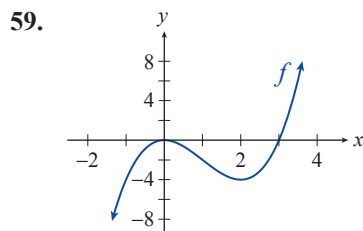

**WRITING & THINKING**

For Exercises 61–65, sketch the graph of a function  $f$  possessing the given characteristics. (A formula is useful, but not necessary.)

61.  $f(0) = 1$ ,  $f'(0) = 0$ ,  $f'(x) < 0$  for  $x < 0$ ,  $f'(x) > 0$  for  $x > 0$

62.  $f(1) = 0$ ,  $f'(1) = 0$ ,  $f'(x) \geq 0$  on the entire real line

63.  $f(x) > 0$  on the entire real line,  $f'(x) < 0$  on the entire real line

64.  $f(1) = 1$ ,  $f'(1) = -1$ ,  $f'$  is nonzero on the entire real line

65.  $f(1) = 5$ ,  $f'(x) = 5$  on the entire real line

66. Prove that if  $f(x) = c$  (a constant function), then  $f'(x) = 0$ .

67. Use the definition of the derivative to prove that if  $f(x) = x$ , then  $f'(x) = 1$ .

68. Generalize Exercise 67 to prove that if  $f(x)$  is a linear function, then  $f'(x)$  is constant.

69. Use the definition of the derivative to prove that if  $f(x) = x^n$  for a positive integer  $n$ , then  $f'(x) = nx^{n-1}$ .
70. Recall from Section 4.2 that a function  $f$  is even if  $f(-x) = f(x)$  and odd if  $f(-x) = -f(x)$  throughout its domain. Prove that the derivative of an even function is odd and, vice versa, an odd function has an even derivative.
71. Find the equation of the line tangent to the graph of  $f(x) = \frac{1}{x}$  at the point  $(c, f(c))$ . Prove that the area of the triangle bounded by the tangent line and the coordinate axes is the same for all  $c \neq 0$ .

### APPLICATIONS

72. The position function of a moving particle is given by  $p(t) = t^2 - 3t + 1$  feet at  $t$  seconds. Find all points in time where the particle's speed is 1 ft/s. When does it come to a momentary stop?
73. Repeat Exercise 72 with the position function  $p(t) = \frac{1}{9}t^3 - t^2 + \frac{8}{3}t$ .
74. A baseball is hit vertically upward with an initial speed of 80 ft/s. When does it slow down to 32 ft/s? How high does it go and how long is it aloft? (**Hint:** Use the position function  $h(t) = -16t^2 + 80t$ . Ignore air resistance.)
75. A rock is thrown upward from the edge of a 150 ft high cliff with an initial velocity of 48 ft/s.
- Calculate the velocity and speed of the rock when it is exactly 32 ft above the person's hand.
  - How high does it go and when does it reach the bottom of the cliff?
  - What is the velocity of impact?
- (**Hint:** Use  $h(t) = -16t^2 + 48t + 150$  as the position function, where  $h$  is in feet,  $t$  in seconds. Ignore air resistance.)
76. A package is dropped from a small airplane 122.5 meters above the Earth. If we ignore air resistance, how much time does the package need to reach the ground and what is the speed of impact? (**Hint:** The position function is  $h(t) = -4.9t^2 + 122.5$  meters, where  $t$  is measured in seconds. Use  $g \approx 9.81 \text{ m/s}^2$ .)
77. The following graph is a position function of a student's car relative to her home as she drove to class one morning. From the graph, recreate a possible story of her trip, mentioning distance, velocity, speed, and so forth.

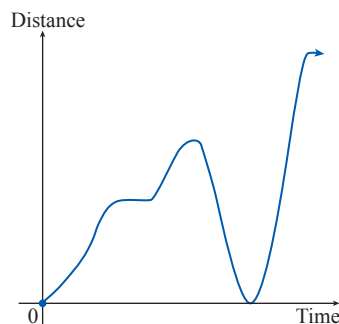

78. A manufacturer has determined that the revenue from the sale of  $x$  cordless telephones is given by  $R(x) = 94x - 0.03x^2$  dollars. The cost of producing  $x$  telephones is  $C(x) = 10,800 + 34x$  dollars.
- Find the profit function  $P(x)$  and any break-even points.
  - Find  $P(200)$ ,  $P(400)$ , and  $P(600)$ .
  - Find the marginal profit function  $P'(x)$ .
  - Find  $P'(200)$ ,  $P'(400)$ , and  $P'(600)$ .
79. The owner of a leather retailer has determined that he can sell  $x$  attaché cases if the price is  $p = D(x) = 46 + 0.25x$  dollars ( $D(x)$  is often called the demand function). The total cost for these cases is  $C(x) = 0.15x^2 + 6x + 190$  dollars.
- Find the profit function  $P(x)$ . (**Hint:** Find the revenue function  $R(x)$  first.)
  - Find any break-even points.
  - Find  $P(25)$ ,  $P(30)$ , and  $P(40)$ .
  - Find the marginal profit function  $P'(x)$ .
  - Find  $P'(25)$ ,  $P'(30)$ , and  $P'(40)$ .
80. The average cost  $\bar{C}(x)$  of manufacturing  $x$  units of a certain product is  $\frac{C(x)}{x}$ , where  $C(x)$  is the total cost function.
- Find the average cost function if  $C(x) = 30 + 2x + 0.003x^2$ .
  - What is the rate of change of average cost?
  - What value of  $x$  results in a minimum average cost? (**Hint:** Use the fact that when average cost is a minimum, its rate of change is 0. Alternatively, use a graphing utility to graph  $C(x)$  for  $x \geq 0$  and zoom in on the lowest point.)
81. The average manufacturing cost function of a product is given by  $\bar{C}(x) = 20x^{-1} + 3$ . Determine the cost function and the marginal cost function for the product. (**Hint:** See Exercise 80.)

 TECHNOLOGY

- 82–105. Referring back to the functions given in Exercises 15–38, use a graphing utility to sketch the graph of  $f$  along with that of  $f'$  in the same viewing window. Compare the graphs and describe their relationship.