

Completion Example Answers

9. $3x - y = 15$
 $3x - y - 3x = 15 - 3x$ Subtract $3x$ from both sides.
 $-y = 15 - 3x$
 $-1(-y) = -1(15 - 3x)$ Multiply both sides by -1 (or divide both sides by -1).
 $y = -15 + 3x$ Simplify using the distributive property.
 or $y = 3x - 15$

Margin Exercise Answers

1. \$2020 2. $F = 122^\circ\text{F}$ 3. 1,012,500 lb 4. 30° 5. $I = \frac{P}{V}$ 6. $t = \frac{I}{Pr}$ 7. $x = \frac{5}{2}y - 3$
 8. a. $y = \frac{400 - 25z}{16}$ or $y = -\frac{25}{16}z + 25$ b. $z = \frac{400 - 16y}{25}$ or $z = -\frac{16}{25}y + 16$ 9. $x = 4 - 2y - 3z$

2.3 Exercises

Concept Check

Fill-in-the-Blank. Complete the sentences using information found in this section.

- Formulas are general rules or principles stated _____.
- The _____ earned by investing money is equal to the product of the principle times the rate of interest times the time in one year or part of a year.
- The distance traveled equals the product of the rate of speed and the _____.
- The _____ of a rectangle is equal to twice the length plus twice the width.
- If you know values for all but one variable in a formula, you can _____ those values and find the value of the unknown variable by solving the equation.
- If you want to use a formula in another form, treat the variables just as you would _____ in solving linear equations.

True/False. Determine whether each statement is true or false. If a statement is false, explain how it can be changed so the statement will be true. (**Note:** There may be more than one acceptable change.)

- When using formulas, typically it does not matter if capital or lower case letters are used: $A = a$, $C = c$, etc.
- If the perimeter and length are known, $P = 2l + 2w$ can be used to find the width of a rectangle.
- Rate of interest is stated as an annual rate in percent form.

Applications

Solve. See Exmple 1. (Note: Use 365 days in a year and 30 days in each month.)

Simple Interest

1. You want to borrow \$4000 at 12% for only 90 days. How much interest would you pay?
2. For how many days must you leave \$1000 in a savings account at 5.5% to earn \$11.00 in interest?
3. What principal would you need to invest to earn \$450 in simple interest in 6 months if the interest rate was 9%?
4. After 30 days, Gustav received \$25 in simple interest on his savings account of \$12,000. What was the interest rate?
5. A savings account of \$3500 is left for 9 months and draws simple interest at a rate of 7%.
 - a. How much interest is earned?
 - b. What is the balance in the account at the end of the 9 months?
6. Tim just deposited \$2562.50 to pay off a 3 month loan of \$2500.
 - c. How much of what he deposited was interest on the loan?
 - d. What rate of interest was he charged?

Solve using substitution. See Examples 1 through 4.

Velocity

If an object is shot upward with an initial velocity v_0 in feet per second, the velocity v in feet per second is given by the formula $v = v_0 - 32t$, where t is time in seconds. (v_0 is read “ v sub zero.” The $_0$ is called a subscript.)

7. An object projected upward with an initial velocity of 106 feet per second has a velocity of 42 feet per second. How many seconds have passed?
8. Find the initial velocity of an object if the velocity after 4 seconds is 48 feet per second.

Medicine

In nursing, one procedure for determining the dosage for a child is

$$\text{child's dosage} = \frac{\text{age of child in years}}{\text{age of child} + 12} \cdot \text{adult dosage.}$$

9. If the adult dosage of a drug is 20 milliliters, how much should a 3-year-old child receive?
10. If the adult dosage of a drug is 340 milligrams, how much should a 5-year-old child receive?

Investments

The total amount of money in an account with P dollars invested in it is given by the formula $A = P + Prt$, where r is the rate expressed as a decimal and t is time (one year or part of a year).

11. If \$1000 is invested at 6% interest, find the total amount in the account after 6 months.
12. How long will it take an investment of \$600, at an annual rate of 5%, to be worth \$615?

Construction

The number N of rafters in a roof or studs in a wall can be found by the formula $N = \frac{L}{d} + 1$, where L is the length of the roof or wall and d is the center-to-center distance from one rafter or stud to the next. Note that L and d must be in the same units.

13. How many rafters will be needed to build a roof 26 ft long if they are placed 2 ft apart center-to-center?
14. A wall has studs placed 16 in. apart center-to-center. If the wall is 20 ft long, how many studs are in the wall?

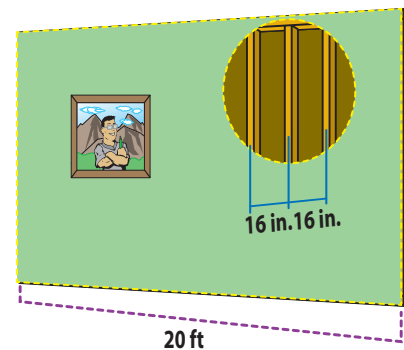
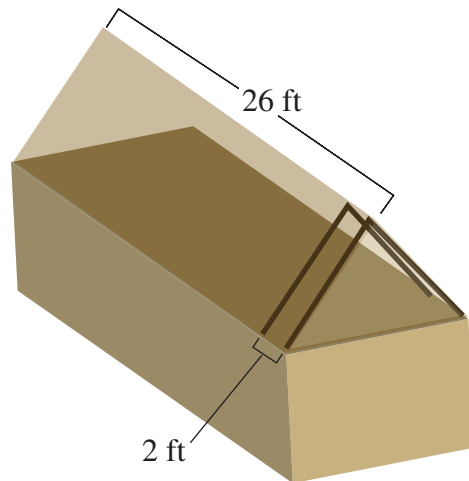

15. How long is a wall if it requires 22 studs placed 16 in. apart center-to-center?
16. What should the center-to-center distance be if you are building a 33 ft long roof using 12 rafters?

Cost

The total cost C of producing x items can be found by the formula $C = ax + k$, where a is the cost per item and k is the fixed costs (rent, utilities, and so on).

17. Find the total cost of producing 30 items if each costs \$15 and the fixed costs are \$580.

18. The total cost to produce 80 dolls is \$1097.50. If each doll costs \$9.50 to produce, find the fixed costs.
19. It costs a company \$3.60 to produce a calculator. Last week the total costs were \$1308. If the fixed costs are \$480 weekly, how many calculators were produced last week?
20. Each week an electronics company builds 60 smartphones for a total cost of \$5340. If the fixed costs for a week are \$750, what is the cost to produce each smartphone?
21. In 1981, the U.S. demand for wheat was given by $q = 3550 - 266p$, where q is measured in millions of bushels and p is the price in dollar per bushel. Determine the price per bushel when the demand hit 2630 million bushels.

Profit

The profit P is given by the formula $P = R - C$, where R is the revenue and C is the cost.

22. Find the revenue (income) of a company that shows a profit of \$3.2 million and costs of \$1.8 million.
23. Find the revenue of a company that shows a profit of \$3.2 million and costs of \$5.7 million.

Depreciation

Many items decrease in value as time passes. This decrease in value is called depreciation. One type of depreciation is called linear depreciation. The value V of an item after t years is given by $V = C - Crt$, where C is the original cost and r is the rate of depreciation expressed as a decimal.

24. If you buy a car for \$6000 and it depreciates linearly at a rate of 10% per year, what will be its value after 6 years?
25. A contractor buys a 4-year-old piece of heavy equipment valued at \$20,000. If the original cost of this equipment was \$25,000, find the rate of depreciation.

Distance, Rate, Time

The distance traveled d is given by the formula $d = rt$, where r is the rate of speed and t is the time it takes.

26. How long will a truck driver take to travel 350 miles if he averages 50 mph?
27. What is the average rate of speed of a biker who bikes 21.92 miles in 68.5 minutes?
28. What is Jonathan's average rate of speed if he hikes 10.4 miles in 6.4 hours?
29. How long will it take a train traveling at 40 mph to go 140 miles?

Solve each formula for the indicated variable. See Examples 5 through 9.

- | | |
|---|--|
| 30. $P = a + b + c$; solve for b . | 49. $v = -gt + v_0$; solve for t . |
| 31. $P = 3s$; solve for s . | 50. $A = \frac{1}{2}bh$; solve for b . |
| 32. $F = ma$; solve for m . | 51. $R = \frac{E}{I}$; solve for I . |
| 33. $C = \pi d$; solve for d . | 52. $V = \pi r^2 h$; solve for h . |
| 34. $A = lw$; solve for w . | 53. $A = \frac{R}{2L}$; solve for L . |
| 35. $P = R - C$; solve for C . | 54. $K = \frac{mv^2}{2g}$; solve for g . |
| 36. $R = np$; solve for n . | 55. $x + 4y = 4$; solve for y . |
| 37. $v = k + gt$; solve for k . | 56. $2x + 3y = 6$; solve for y . |
| 38. $I = A - P$; solve for P . | 57. $3x - y = 14$; solve for y . |
| 39. $L = 2\pi rh$; solve for h . | 58. $5x + 2y = 11$; solve for x . |
| 40. $A = \frac{m+n}{2}$; solve for m . | 59. $-2x + 2y = 5$; solve for x . |
| 41. $P = a + 2b$; solve for a . | 60. $A = \frac{1}{2}h(b+c)$; solve for b . |
| 42. $I = Prt$; solve for t . | 61. $A = P(1+rt)$; solve for r . |
| 43. $R = \frac{E}{I}$; solve for E . | 62. $R = \frac{3(x-12)}{8}$; solve for x . |
| 44. $P = a + 2b$; solve for b . | 63. $-2x - 5 = -3(x+y)$; solve for x . |
| 45. $c^2 = a^2 + b^2$; solve for b^2 . | 64. $3y - 2 = x + 4y + 10$; solve for y . |
| 46. $\alpha + \beta + \gamma = 180^\circ$; solve for β . | 65. $V = \frac{1}{3}\pi r^2 h$; solve for h . |
| 47. $y = mx + b$; solve for x . | |
| 48. $V = lwh$; solve for h . | |

Determine a formula for each of the following situations.

66. Each ticket for a concert costs $\$t$ per person and parking costs $\$9.00$. What is the total cost per car C if there are n people in a car?
67. A-to-Z Truck Rentals charges $\$25$ per day plus $\$0.75$ per mile for a 10-foot rental truck. What would you pay per day for renting the truck from A-to-Z if you were to drive the truck x miles in one day?
68. Top-of-the-Line computer company knows that the cost (labor and materials) of producing a computer is $\$325$ per computer per week and the fixed overhead costs (lighting, rent, etc.) are $\$5400$ per week. What are the company's weekly costs of producing n computers per week?

69. If the Top-of-the-Line computer company (see Exercise 67) sells its computers for \$683 each, what is its profit per week if it sells the same number n that it produces? (Remember that profit is equal to revenue minus costs, or $P = R - C$.)

Solve.

70. Samantha uses a credit promotion at a home improvement store where she doesn't have to pay any interest on her purchase as long as she pays off the entire balance within 6 months. She purchases \$8000 in merchandise. If she fails to pay off the balance within 6 months, then she will be charged \$600 in interest. Samantha lost the paper work and wants to determine the interest rate on her purchase.
- Which formula from Table 1 fits this situation?
 - Match the variables in the formula from Part **a.** to the information provided.
 - The formula from Part **a.** needs to be solved for which variable?
 - What is the interest rate on her purchase? (Remember to convert to a percent.)
71. In a physics lab, a ball is rolled down an incline that has a machine at the bottom which calculates the force of impact. The ball has a mass of 1.5 kilograms. After several trials, the average force of impact is calculated to be $12.75 \text{ kg} \cdot \text{m/s}^2$. The researchers need to determine the average acceleration of the ball at the moment it struck the machine.
- Which formula from Table 1 fits this situation?
 - Match the variables in the formula from Part **a.** to the information provided.
 - The formula from Part **a.** needs to be solved for which variable?
 - What was the average acceleration of the ball in m/s^2 ?
72. Charles is experimenting with a new sail design for his sailboat and needs to keep the total area of the triangular sail to 150 square feet. The base of the sail must be exactly 3 times the height of the sail.
- What geometric formula for area should be used?
 - Write an expression for the base of the formula using the variable h for height.
 - Substitute the expression from Part **b.** into the area formula for the base.
 - Solve this formula for the height squared.
 - What would you have to do to both sides of the equation in Part **d.** to solve the formula for the height?
 - Substitute 150 for the area of the sail in the formula from Part **d.** and solve for the height of the sail.
 - What is the length of the base of the sail?

Writing & Thinking

73. The formula $z = \frac{x - \bar{x}}{s}$ is used extensively in statistics. In this formula, x represents one value in a set of data, \bar{x} represents the average (or mean) of those numbers in the set, and s represents a value called the standard deviation of the numbers. (The standard deviation is a positive number and is a measure of how “spread out” the numbers are.) The values for z are called z -scores, and they measure the number of standard deviation units a number x is from the average \bar{x} .

- a. If $\bar{x} = 70$, what will be the z -score for $x = 70$? Does this z -score depend on the value of s ? Explain.

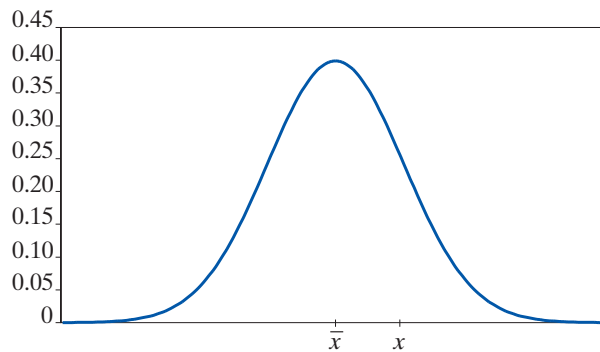

- b. For what values of x will the corresponding z -scores be negative?
- c. Calculate your z -score on each of the last two test scores in this class. (Your instructor will give you the average and standard deviation for each test.) What do these scores tell you about your performance on the two exams?
74. Suppose that, for a particular set of exam scores, $\bar{x} = 72$ and $s = 6$. Find the z -score that corresponds to each of the following scores.
- 78
 - 66
 - 81