

Completion Example Answers

8. $9(-1+4)-7-6\cdot 4$; $9(3)-7-6\cdot 4$; $27-7-6\cdot 4$; $27-7-24$; $20-24$; -4

Margin Exercise Answers1. a. $100^3 = 1,000,000$ b. $2^4 = 16$ c. $1^3 = 1$ d. $8^2 = 64$ 2. a. 81 b. 32 c. 625 3. a. -10 b. 4
4. a. 81 b. -81 5. 5 6. -3 7. -6 8. -12 9. 9°F 10. a. 116,800 cars b. 393,300 cars

1.1 Exercises

Concept Check

Fill-in-the-Blank. Complete each sentence using information found in this section.

- The set of whole numbers consists of the natural numbers and the number ____.
- Exponents are used to represent repeated _____.
- In 2^4 the “2” is called the _____ and the “4” is called the _____.
- If there are multiple grouping symbols to be simplified, begin with the _____ group.
- The last operations to be performed are _____ and _____.
- The _____ of a set of integers is found by dividing the sum of the integers by the number of integers in the set.

True/False. Determine whether each statement is true or false. If a statement is false, explain how it can be changed so the statement will be true. (**Note:** There may be more than one acceptable change.)

- Zero is its own opposite.
- Nine squared is equal to eighteen.
- According to the order of operations, multiplication is always performed before division.

Practice

Rewrite each product by using exponents. See Example 1.

- | | |
|--|---|
| 1. $11 \cdot 11 \cdot 11$ | 6. $2 \cdot 2 \cdot 5 \cdot 5 \cdot 5$ |
| 2. $13 \cdot 13 \cdot 13$ | 7. $5 \cdot 5 \cdot 5 \cdot 7 \cdot 7$ |
| 3. $7 \cdot 7 \cdot 7 \cdot 7$ | 8. $3 \cdot 3 \cdot 3 \cdot 7 \cdot 7 \cdot 7$ |
| 4. $6 \cdot 6 \cdot 6 \cdot 6 \cdot 6$ | 9. $2 \cdot 3 \cdot 3 \cdot 11 \cdot 11$ |
| 5. $2 \cdot 2 \cdot 2 \cdot 3 \cdot 3$ | 10. $2 \cdot 2 \cdot 2 \cdot 2 \cdot 11 \cdot 11 \cdot 13 \cdot 13$ |

For each exponential expression **a.** identify the base, **b.** identify the exponent, and **c.** evaluate the exponential expression. See Example 2.

11. 4^2

12. 6^2

13. 2^3

14. 3^3

15. 1^6

16. 1^5

17. 5^3

18. 4^3

19. 2^4

20. 2^6

21. 9^2

22. 11^2

23. 7^2

24. 7^3

25. 3^5

26. 4^5

27. 30^2

28. 40^2

29. 20^3

30. 15^2

31. 1^{57}

32. 1^{99}

33. 4^0

34. 19^0

35. 13^1

36. 24^1

37. 22^0

38. 99^0

Simplify each expression using the order of operations. See Example 4.

39. -8^2

40. -4^2

41. $(-4)^2$

42. $(-8)^2$

43. -4^3

44. -5^3

45. $(-5)^3$

46. $(-4)^3$

Simplify each expression using the order of operations. See Examples 3 through 8.

47. $\frac{18+9}{-9}$

48. $\frac{27+9}{-9}$

49. $\frac{25-4^2}{3}$

50. $\frac{50-6^2}{2}$

51. $15 \div (-5) \cdot 2 - 8$

52. $16 \div (-4) \cdot 2 - 9$

53. $3^3 \div (-9) \cdot 4 + 5(-2)$

54. $20 \cdot 2 \div (-10) + 5(-4)$

55. $-6^2 + 7(12) - 3^2$

56. $-10^2 - 4(-8) - 5^2$

57. $4^2 \div (-8)(-2) + 6(-15 + 3 \cdot 5)$

58. $5^2 \div (-5)(-3) - 2(4 \cdot 3)$

59. $[15 + 5(-2^3 - 7)] \div 10$

60. $[20 - 4(-3^2 - 6)] \div 8$

61. $5^2 - 6 \cdot |-3| + 2(5 + 2^3)$

62. $(-6)^2 - 4 \cdot |-2| + 5(7 - 3^2)$

63. $-27 \div (-|3|) - 14 - 4(-2)^3$

64. $-32 \div (-|4|) + 16 - 2(-3)^3$

65. $7 \cdot 2^3 + 3^2 - 4^2 - 4(6 - 2 \cdot 3)$

66. $5 \cdot 2^4 + 5^2 - 6^2 - 7(12 - 3 \cdot 4)$

69. $-|2 - 5| \left[49 \div (-7) + 4 \cdot 3 - 6 \cdot 2 + 10 \right]$

67. $13 - |-2| \left[(19 - 14) \div 5 + 3(-4) - 5 \right]$

70. $-|9 - 11| \left[(-10)^2 \cdot 2 + 6(-5)^2 - 10^3 \right]$

68. $2 - |-5| \left[(-10) \div (-5) \cdot 2 - 35 \right]$

 Use a calculator to simplify each expression.

71. $(-72)^2 - 35(16)$

74. $(32 - 50)^2 (15 - 22)^2 (17 - 20)$

72. $(15)^3 - 60 + 13(-5)$

75. $6 - 20 \left[(-15) \cdot |-2| + 4(-5) - 1 \right]$

73. $(15 - 20)(13 - 14)^2 + 50(-2)$

76. $14^2 - 15 \left[(-5 - 3)^2 + 7(-6) - |-2| \right]$

Solve.

77. If the product of -15 and -6 is added to the product of -32 and 5 , what is the sum?

78. If the quotient of -56 and 8 is subtracted from the product of -12 and -3 , what is the difference.

79. a. What number should be added to -5 to get a sum of -22 ?

b. What number should be added to $+5$ to get a sum of -22 ?

80. a. What number should be added to -39 to get a sum of -13 ?

b. What number should be added to $+39$ to get a sum of -13 ?

Find the average of each group of integers.

81. $-10, -20, 14, 34, -18$

83. $-6, -8, -7, -4, -4, -5, -6, -8$

82. $56, -64, -38, 58, -12$

84. $-25, 30, -15, -6, -26, 18$

Applications

Solve.

85. Neville bought 15 boxes of trading cards. Each box has 10 packs of trading cards. Each pack of trading cards contains 20 cards. He adds 132 cards that he already owns to the newly purchased cards. Then, Neville evenly distributes all of the cards to 6 of his friends. How many trading cards would each person get?

a. If you simplify the expression $15 \cdot 10 \cdot 20 + 132 \div 6$ using the order of operations, will you get the correct answer? If not, explain what is wrong with the expression.

b. What is the answer? If necessary, write the corrected expression to get the correct results when following the order of operations.

86. Robert is purchasing shirts for his weekend soccer team. The shirts he wants to buy are normally \$25 each but are on sale for \$10 off. His team has a total of 11 players. How much will he spend to buy the shirts?

a. If you simplify the expression $\$25 - \$10 \cdot 11$ using the order of operations, will you get the correct answer? If not, explain what is wrong with the expression.

b. What is the answer? If necessary, write the corrected expression to get the correct results when following the order of operations.

87. Alicia bought shares of two companies on the stock market. She paid \$9000 for 90 shares in one company and \$6600 for 110 shares in another company. What was the average price per share for the 200 shares?
88. In a weight lifting program, two men bench pressed 300 pounds, three men bench pressed 350 pounds, and 5 men bench pressed 400 pounds. What was the average number of pounds that these men bench pressed?
89. On an English exam, two students scored 95, six students scored 90, three students scored 80, and one student scored 50. What was the average score for the class?
90. In a speech class, the students graded each other on a particular assignment. On this speech, three students scored 60, three scored 70, five scored 80, five scored 82, and four scored 85. What was the average score on this speech?
91. In the 2022 Masters Tournament, Collin Morikawa shot scores of 73, 70, 74, and 67 in four rounds of play.
- What was his average score in each round?
 - Par was 72 on that course. How many strokes under par was his average score?
92. In the 2022 Masters Tournament, Cameron Champ shot scores of 72, 75, 71, and 70 in four rounds of play.
- What was his average score in each round?
 - Par was 72 on that course. How many strokes under par was his average score?
93. 📊 The temperature readings for 30 days at a ski resort were recorded as follows. (All temperatures were measured in degrees Fahrenheit.)

| | | | | | |
|-----|----|----|----|-----|-----|
| 28 | 24 | 22 | 10 | -2 | -5 |
| -2 | 12 | 10 | 15 | -6 | 5 |
| 20 | 13 | -2 | -6 | -15 | -18 |
| -10 | 8 | -1 | 7 | 20 | 21 |
| 32 | 30 | 22 | 12 | 3 | -7 |

What was the average temperature recorded for the 30 days?

94. 📊 The approximate box office gross income (to the nearest thousand dollars) of the 5 top-grossing movies of 2020 are listed below. Find the average gross income of these 5 movies.

| Motion Picture | US Gross (\$) |
|--|---------------|
| <i>Bad Boys for Life</i> | 204,418,000 |
| <i>1917</i> | 157,901,000 |
| <i>Sonic the Hedgehog</i> | 146,066,000 |
| <i>Jumanji: The Next Level</i> | 124,737,000 |
| <i>Star Wars: Episode IX - The Rise of Skywalker</i> | 124,496,000 |

Source: www.boxofficemojo.com

Writing & Thinking

95. Explain how someone might think that $1 + 3^2 = 16$. Then, explain why this would not be correct.
96. Explain the potential mistake students may make when using the mnemonic device PEMDAS as their guide for simplifying numerical expressions.

Tests for Divisibility

As mentioned in the note earlier in the section, here are the quick tests for divisibility.

A number is divisible

By 2: if the units digit is 0, 2, 4, 6, or 8.

By 3: if the sum of the digits is divisible by 3.

By 4: if the number formed by the last two digits is divisible by 4.

By 5: if the units digit is 0 or 5.

By 6: if the number is divisible by both 2 and 3.

By 9: if the sum of the digits is divisible by 9.

By 10: if the units digit is 0.

PROCEDURE

Margin Exercise Answers

1. **a.** 13 has exactly two factors, 1 and 13. **b.** 19 has exactly two factors, 1 and 19. **2. a.** 1, 5, and 25 are all factors of 25. **b.** 1, 2, 4, 8, 16, and 32 are all factors of 32. **3.** $2^2 \cdot 5 \cdot 7$ **4. a.** $2 \cdot 37$
b. $-1 \cdot 2^2 \cdot 5^2$ **c.** $2 \cdot 3^2 \cdot 13$ **5.** 126 **6.** 420

1.2 Exercises

Concept Check

Fill-in-the-Blank. Complete each sentence using information found in this section.

1. Every counting number except the number 1 has at least _____ factors.
2. A _____ number is a counting number greater than 1 with exactly two different factors.
3. A number is _____ by another number if the remainder in the division process is 0.
4. If a whole number is not divisible by _____, then it is odd.
5. The _____ factorization of a number is the product of all prime factors of that number.
6. The least common multiple of two or more counting numbers is the _____ number that is a multiple of each of those numbers.

True/False. Determine whether each statement is true or false. If a statement is false, explain how it can be changed so the statement will be true. (**Note:** There may be more than one acceptable change.)

-
7. A composite number is a counting number with exactly two different factors.
 8. An even number is a number that is divisible by 2.
 9. Each composite number has exactly one prime factorization.
 10. A number is divisible by 3 if the units digit is divisible by 3.

Practice

Determine which numbers, if any, in each set of counting numbers are prime. See Example 1.

-
- | | |
|---------------------|-----------------------------|
| 1. {13, 15, 17, 21} | 3. {2, 4, 6, 8, 10, 12, 14} |
| 2. {11, 19, 23, 51} | 4. {7, 16, 25, 36, 47, 49} |

Find two factors of each number (other than 1 and the number itself) to determine that the number is composite. (Answers will vary.) See Example 2.

-
- | | |
|--------|---------|
| 5. 72 | 10. 417 |
| 6. 63 | 11. 170 |
| 7. 68 | 12. 99 |
| 8. 39 | 13. 444 |
| 9. 502 | 14. 230 |

Find the prime factorization of each of the numbers. If a number is prime, write "prime." See Examples 3 and 4.

-
- | | |
|----------|----------|
| 15. 52 | 25. 125 |
| 16. 60 | 26. 343 |
| 17. 616 | 27. -400 |
| 18. 460 | 28. -500 |
| 19. -308 | 29. 120 |
| 20. -155 | 30. 196 |
| 21. 79 | 31. 231 |
| 22. 43 | 32. 675 |
| 23. 289 | 33. 1692 |
| 24. 361 | 34. 1716 |

35. List the first ten **multiples** of each number.
- | | |
|------|-------|
| a. 5 | c. 10 |
| b. 6 | d. 15 |
36. From the lists you made in Exercise 35, find the least common multiple for each of the following sets of numbers.
- | | |
|------------|----------------|
| a. {5, 6} | c. {5, 10, 15} |
| b. {6, 10} | d. {6, 10, 15} |

Find the LCM of each of the following sets of counting numbers. See Examples 5 and 6.

- | | |
|------------------|--------------------------|
| 37. {3, 5, 7} | 54. {14, 28, 56} |
| 38. {2, 7, 11} | 55. {20, 50, 100} |
| 39. {8, 10} | 56. {30, 60, 120} |
| 40. {9, 12} | 57. {10, 15, 25} |
| 41. {2, 3, 11} | 58. {22, 44, 121} |
| 42. {3, 5, 13} | 59. {26, 28, 91} |
| 43. {4, 14, 35} | 60. {34, 51, 54} |
| 44. {10, 12, 20} | 61. {35, 40, 72} |
| 45. {50, 75} | 62. {30, 35, 63} |
| 46. {30, 70} | 63. {12, 21, 44} |
| 47. {20, 90} | 64. {20, 28, 45} |
| 48. {50, 80} | 65. {99, 121, 231} |
| 49. {28, 98} | 66. {81, 225, 324} |
| 50. {45, 75} | 67. {48, 120, 144, 192} |
| 51. {10, 15, 35} | 68. {125, 135, 225, 250} |
| 52. {6, 24, 30} | 69. {40, 56, 160, 196} |
| 53. {15, 45, 90} | 70. {35, 49, 63, 126} |

Applications

Solve.

71. Two astronauts miss connections at their first meeting in space.
- If one astronaut circles the earth every 15 hours and the other every 18 hours, in how many hours will they meet again at the same place?
 - How many more orbits will each astronaut have to complete between missing their first meeting and making their second meeting?

72. Three neighbors mow their lawns at different intervals during the summer months. The first one mows every 5 days, the second every 7 days, and the third every 10 days.
- How frequently do they mow their lawns on the same day?
 - How many times does each neighbor mow in between the times when they all mow together?
73. Four women work for the same book company selling textbooks. They leave the home office on the same day and take 8 days, 12 days, 14 days, and 15 days, respectively, to visit schools in their own sales regions.
- In how many days will they all meet again at the home office?
 - How many sales trips will each have made in this time?
74. A fruit production company has three packaging facilities, each of which uses different-sized boxes as follows: 24 pieces/box, 36 pieces/box, and 45 pieces/box.
- Assuming that the truck provides the same quantity of uniformly-sized pieces of fruit to all three packaging facilities, what is the minimum number of pieces of fruit that will be delivered so that no fruit will be left over?
 - How many boxes will each facility package?
75. Three swimmers decide to swim laps together, and they will quit when they reach the starting end of the pool together. The first swimmer can swim a lap in 35 seconds, the second will take 40 seconds, and the third takes 42 seconds.
- How many seconds will it take before they quit?
 - How many laps will each swimmer swim in that interval?
76. Two analog clocks are sitting next to each other. The first clock keeps perfect time, where the minute hand takes 60 minutes to travel completely around the dial. The second clock runs fast and the minute hand makes one complete revolution in 55 minutes.
- Assuming that both clocks are started so that the minute hands are at 12, how many minutes will it take until both minute hands return to 12 at the same time?
 - How many hours does this represent?

Writing & Thinking

77. List five prime numbers larger than 50.
78. Describe, in your own words, how to find the LCM of a set of counting numbers.
79.
 - Explain why 1 is not a prime number.
 - Explain why 1 is not a composite number.

Margin Exercise Answers

1. a. $\frac{2}{5}$ b. $\frac{3}{5}$ 2. $\frac{22}{27}$ 3. $\frac{15}{32}$ 4. a. $\frac{28}{5}$ or $5\frac{3}{5}$ b. 0 c. $\frac{9}{70}$ 5. 8 6. 15 7. $\frac{3}{5}$ 8. $\frac{8}{11}$

9. a. $\frac{5}{7}$ b. $\frac{2}{7}$ 10. $\frac{7}{36}$ 11. $\frac{4}{15}$ 12. $\frac{4}{3}$ or $1\frac{1}{3}$ 13. $\frac{7}{45}$ 14. $\frac{4}{3}$ or $1\frac{1}{3}$ 15. a. More than 30 pieces b. Less than 30 c. 50 pieces

1.3 Exercises

Concept Check

Fill-in-the-Blank. Complete each sentence using information found in this section.

- If a fraction has a numerator that is equal to or larger than the denominator, it is a/an _____ fraction.
- A fraction that has a zero in the denominator is considered to be _____.
- Any whole number can be written in fraction form with denominator _____.
- Finding a fraction “of” a number requires _____.
- If all the factors in the numerator or denominator are divided out, then _____ must be used as a factor.
- Finding _____ factorizations may help in multiplying and reducing at the same time.

True/False. Determine whether each statement is true or false. If a statement is false, explain how it can be changed so the statement will be true. (**Note:** There may be more than one acceptable change.)

- In $\frac{11}{13}$, the denominator is 11.
- $\frac{17}{0}$ is undefined.
- To find $\frac{1}{2}$ of $\frac{2}{9}$ requires multiplication.
- The reciprocal of $\frac{2}{7}$ is $\frac{5}{7}$.

Practice

Draw a figure to represent each fraction. .

1. $\frac{1}{3}$

2. $\frac{1}{2}$

3. $\frac{4}{5}$

4. $\frac{3}{4}$

Write a fraction that indicates the shaded parts of each figure. See Example 1.

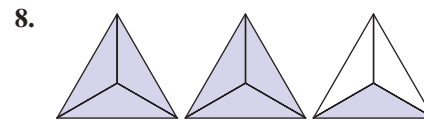
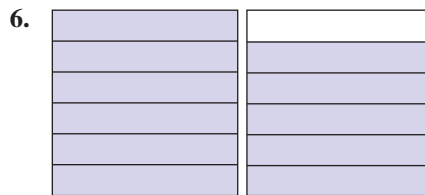
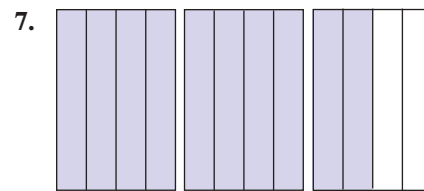
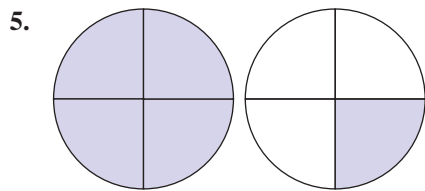

Multiply. See Examples 2 through 4.

9. $\frac{1}{7} \cdot \frac{1}{7}$

10. $\frac{2}{5} \cdot \frac{2}{5}$

11. $\frac{0}{4} \cdot \frac{7}{6}$

12. $\frac{2}{1} \cdot \frac{5}{1}$

13. $\frac{3}{5} \cdot \frac{4}{7}$

14. $\frac{2}{3} \cdot \frac{5}{11}$

15. $\frac{5}{8} \cdot \frac{3}{4}$

16. $\frac{7}{6} \cdot \frac{5}{2}$

17. $-\frac{1}{2} \cdot \frac{3}{7} \cdot \frac{9}{2}$

18. $-\frac{7}{3} \cdot \frac{2}{5} \cdot \frac{1}{9}$

19. $\frac{7}{8} \cdot \frac{7}{9} \cdot \frac{7}{3}$

20. $\frac{8}{5} \cdot \frac{8}{5} \cdot \frac{7}{1}$

21. Find $\frac{2}{3}$ of $\frac{2}{15}$.

22. Find $\frac{4}{7}$ of $\frac{3}{5}$.

23. Find $\frac{1}{3}$ of $\frac{2}{3}$.

24. Find $\frac{1}{4}$ of $\frac{3}{4}$.

Find the missing numerator that will make the fractions equivalent. See Examples 5 and 6.

25. $\frac{3}{4} = \frac{3}{4} \cdot \frac{?}{?} = \frac{?}{12}$

26. $\frac{2}{3} = \frac{2}{3} \cdot \frac{?}{?} = \frac{?}{12}$

27. $\frac{6}{7} = \frac{6}{7} \cdot \frac{?}{?} = \frac{?}{14}$

28. $\frac{5}{8} = \frac{5}{8} \cdot \frac{?}{?} = \frac{?}{40}$

29. $\frac{3}{16} = \frac{3}{16} \cdot \frac{?}{?} = \frac{?}{80}$

30. $\frac{1}{17} = \frac{1}{17} \cdot \frac{?}{?} = \frac{?}{51}$

31. $\frac{7}{26} = \frac{7}{26} \cdot \frac{?}{?} = \frac{?}{52}$

32. $\frac{9}{10} = \frac{9}{10} \cdot \frac{?}{?} = \frac{?}{100}$

33. $\frac{18}{1} = \frac{18}{1} \cdot \frac{?}{?} = \frac{?}{3}$

34. $\frac{1}{5} = \frac{1}{5} \cdot \frac{?}{?} = \frac{?}{75}$

Reduce each fraction to lowest terms. If it is already in lowest terms, simply rewrite the fraction. See Examples 7 and 8.

35. $\frac{3}{9}$

42. $\frac{0}{16}$

48. $\frac{12}{35}$

36. $\frac{2}{8}$

43. $\frac{12}{35}$

49. $\frac{48}{12}$

37. $-\frac{9}{12}$

44. $\frac{27}{56}$

50. $\frac{72}{36}$

38. $-\frac{6}{20}$

45. $\frac{16}{-32}$

51. $\frac{24}{100}$

39. $\frac{5}{11}$

46. $\frac{25}{-50}$

52. $\frac{70}{100}$

40. $\frac{7}{13}$

47. $\frac{42}{63}$

53. $\frac{150}{-135}$

41. $\frac{0}{25}$

54. $\frac{140}{-112}$

Multiply and reduce to lowest terms. See Examples 10 through 12. (**Hint:** Factor before multiplying.)

55. $\frac{1}{3} \cdot \frac{3}{4}$

61. $\frac{7}{8} \cdot \frac{9}{14}$

68. $9 \cdot \frac{7}{24}$

56. $\frac{3}{7} \cdot \frac{5}{3}$

62. $\frac{8}{10} \cdot \frac{5}{4}$

69. $\left(\frac{32}{20}\right)\left(\frac{13}{9}\right)\left(-\frac{7}{26}\right)$

57. $\frac{2}{3} \cdot \frac{4}{3}$

63. $\frac{2}{21} \cdot \frac{15}{22}$

70. $\left(\frac{20}{32}\right)\left(-\frac{9}{13}\right)\left(\frac{26}{7}\right)$

58. $\frac{3}{5} \cdot \frac{2}{7}$

64. $\frac{3}{16} \cdot \frac{20}{21}$

71. $\frac{9}{10} \cdot \frac{35}{40} \cdot \frac{25}{15}$

59. $\frac{5}{16} \cdot \frac{16}{15}$

65. $\frac{15}{27} \cdot \frac{9}{30}$

72. $\frac{5}{12} \cdot \frac{56}{42} \cdot \frac{90}{54}$

60. $\frac{14}{9} \cdot \frac{3}{14}$

66. $\frac{25}{9} \cdot \frac{3}{100}$

73. $\frac{17}{100} \cdot \frac{27}{34} \cdot \frac{25}{9} \cdot 6$

67. $8 \cdot \frac{5}{12}$

74. $\frac{13}{28} \cdot \frac{7}{9} \cdot \frac{45}{39} \cdot 4$

Divide and reduce to lowest terms. See Examples 13 and 14.

75. $\frac{5}{8} \div \frac{3}{5}$

79. $\frac{3}{14} \div \frac{3}{14}$

83. $\frac{15}{20} \div 3$

76. $\frac{2}{7} \div \frac{1}{2}$

80. $\frac{5}{8} \div \frac{5}{8}$

84. $\frac{14}{20} \div 7$

77. $\frac{2}{3} \div \frac{1}{5}$

81. $\frac{3}{4} \div \frac{4}{3}$

85. $\frac{25}{40} \div 10$

78. $\frac{2}{11} \div \frac{1}{7}$

82. $\frac{9}{10} \div \frac{10}{9}$

86. $\frac{36}{80} \div 9$

87. $-\frac{7}{8} \div 0$

90. $0 \div \frac{1}{2}$

93. $-\frac{15}{24} \div -\frac{25}{18}$

88. $\frac{15}{64} \div 0$

91. $\frac{16}{35} \div \frac{2}{7}$

94. $\frac{36}{25} \div \frac{24}{20}$

89. $0 \div \frac{5}{6}$

92. $-\frac{15}{27} \div -\frac{5}{9}$

Applications

Solve.

95. If you had \$20 and you spent \$9 for a hamburger, fries, and a soft drink, what fraction of your money did you spend? What fraction would you still have?
96. In a class of 35 students, 6 students received As on a mathematics exam. What fraction of students received an A? What fraction of students did not receive an A?
97. A software company receives 45 technical support calls in one hour. Twenty-three of the calls are related to customers forgetting their passwords. What fraction of the calls was related to customers forgetting their passwords?
98. A certain brand of plain bagels has 146 calories per bagel. 115 calories come from the carbohydrates in the bagel. What fraction of the calories is from carbohydrates?
99. What fraction of a minute does 43 seconds represent? (**Hint:** There are 60 seconds in a minute.)
100. There are 5280 feet in a mile. What fraction of a mile does 923 feet represent?
101. The product of $\frac{5}{6}$ with another number is $\frac{2}{5}$.
- Which number is the product?
 - What is the other number?
102. The product of two numbers is 210.
- If one of the numbers is the fraction $\frac{2}{3}$, do you expect the other number to be larger or smaller than 210?
 - What is the other number?
103. An airplane is carrying 90 passengers. This is $\frac{9}{10}$ of the capacity of the airplane.



- Is the capacity of the airplane more or less than 90?
- If you were to multiply 90 times $\frac{9}{10}$ would the product be more or less than 90?
- What is the capacity of the airplane?

- 104.** The student senate has 75 members, and $\frac{7}{15}$ of these are women. A change in the senate constitution is being considered, and at the present time (before debating has begun), a survey shows that $\frac{3}{5}$ of the women and $\frac{4}{5}$ of the men are in favor of this change.
- How many women are on the student senate?
 - How many women on the senate are in favor of the change?
 - If the change requires a $\frac{2}{3}$ majority vote in favor to pass, would the constitutional change pass if the vote were taken today?
 - By how many votes would the change pass or fail?
- 105.** The tennis club has 250 members, and they are considering putting in a new tennis court. The cost of the new court is going to involve an assessment of \$200 for each member. Seven-tenths of the members live quite near the club and $\frac{3}{5}$ of them are in favor of the assessment. However, $\frac{2}{3}$ of the members who do not live nearby are not in favor of the assessment.
- If a vote were taken today, would more than one-half of the members vote for or against the new court?
 - By how many votes would the question pass or fail if more than one-half of the members must vote in favor for the question to pass?
- 106.** There are 3000 students at Mountain High School and $\frac{1}{4}$ of these students are seniors. If $\frac{3}{5}$ of the seniors are in favor of the school forming a debating team and $\frac{7}{10}$ of the remaining students (not seniors) are also in favor of forming a debating team, how many students do not favor this idea?
- 107.** A computer stores data on a hard drive in the form of bits, bytes, and sectors.
- Each byte is made up of eight bits. What fraction of a byte is a bit?
 - A sector on a hard drive is traditionally 512 bytes. A byte is what fraction of a sector?
 - If a computer stores 159 bytes of data, what fraction of a sector does that amount of data take up?
- 108.** The gas tank of a car holds 14 gallons of gas. What fraction of the tank does 9 gallons of gas take up?
- 109.** A small box will hold 12 books. Kathleen has 35 books to pack into small boxes.
- Write an improper fraction to describe the number of boxes that will be filled by Kathleen's books.
 - Change the improper fraction from Part **a.** to a mixed number to describe the number of boxes that will be filled by Kathleen's books.

- 110.** A cup holds 8 ounces of liquid. You have 29 ounces of juice to pour into cups.
- Write an improper fraction to describe the number of cups that will be filled with juice.
 - Change the improper fraction from Part **a.** to a mixed number to describe the number of cups that will be filled with juice.

Writing & Thinking

- 111.** In your own words, list the parts of a fraction and briefly describe the purpose of each part.

Or we can write the fractions vertically.

$$\begin{array}{r} \frac{7}{20} \\ - \frac{3}{28} \\ \hline \end{array} = \frac{7 \cdot 7}{20 \cdot 7} = \frac{49}{140}$$

$$\begin{array}{r} \frac{3}{28} \\ - \frac{3}{28} \\ \hline \end{array} = -\frac{3 \cdot 5}{28 \cdot 5} = -\frac{15}{140}$$

$$\frac{34}{140} = \frac{\cancel{2} \cdot 17}{\cancel{2} \cdot 70} = \frac{17}{70}$$

Now work margin exercise 8.

Margin Exercise Answers

1. $\frac{2}{3}$ 2. $\frac{8}{9}$ 3. $-\frac{3}{20}$ 4. $\frac{5}{12}$ 5. $\frac{13}{30}$, \$13,000 6. $\frac{1}{2}$ 7. $\frac{19}{110}$ 8. $\frac{9}{20}$

1.4 Exercises

Concept Check

Fill-in-the-Blank. Complete each sentence using information found in this section.

- When adding fractions, it is important that the _____ are the same before adding.
- LCD stands for _____.
- The LCD is the least common multiple of the _____.
- When subtracting fractions with the same denominator, _____ the numerators and keep the _____.
- In subtraction with fractions with different denominators, each fraction is changed to a/an _____ fraction with the LCD as its denominator.

True/False. Determine whether each statement is true or false. If a statement is false, explain how it can be changed so the statement will be true. (**Note:** There may be more than one acceptable change.)

- The final step in adding fractions is to reduce, if possible.
- The process for finding the LCD is the same as the process for finding the LCM.
- LCD represents the Least Common Digit.
- When subtracting fractions, simply subtract the numerators and the denominators.
- Subtraction of fractions requires that the fractions have the same denominators.

Practice

Add and reduce to lowest terms. See Examples 1 through 5.

1. $\frac{3}{14} + \frac{2}{14}$

2. $\frac{3}{11} + \frac{7}{11}$

3. $-\frac{7}{5} + \left(-\frac{3}{5}\right)$

- | | | |
|---|---|--|
| 4. $-\frac{9}{10} + \left(-\frac{1}{10}\right)$ | 15. $\frac{1}{4} + \frac{5}{6}$ | 25. $\frac{1}{4} + \left(-\frac{1}{20}\right) + \frac{8}{15}$ |
| 5. $\frac{1}{20} + \frac{3}{20}$ | 16. $\frac{2}{9} + \frac{5}{6}$ | 26. $-\frac{1}{5} + \frac{2}{15} + \frac{1}{6}$ |
| 6. $\frac{3}{25} + \frac{12}{25}$ | 17. $-\frac{2}{5} + \left(-\frac{7}{20}\right)$ | 27. $\frac{1}{5} + \frac{1}{10} + \frac{1}{4}$ |
| 7. $\frac{1}{8} + \frac{3}{8} + \frac{2}{8}$ | 18. $-\frac{3}{4} + \left(-\frac{1}{12}\right)$ | 28. $\frac{1}{5} + \frac{1}{40} + \frac{1}{4}$ |
| 8. $\frac{5}{14} + \frac{4}{14} + \frac{1}{14}$ | 19. $\frac{2}{5} + \frac{3}{10}$ | 29. $-\frac{2}{5} + \left(-\frac{3}{10}\right) + \frac{3}{20}$ |
| 9. $\frac{7}{45} + \frac{11}{45} + \frac{17}{45}$ | 20. $\frac{3}{8} + \frac{5}{16}$ | 30. $-\frac{1}{3} + \frac{5}{36} + \left(-\frac{7}{18}\right)$ |
| 10. $\frac{14}{32} + \frac{7}{32} + \frac{1}{32}$ | 21. $\frac{1}{12} + \frac{2}{3} + \frac{1}{4}$ | 31. $\frac{3}{10} + \frac{1}{100} + \frac{7}{1000}$ |
| 11. $\frac{5}{8} + \frac{3}{4}$ | 22. $\frac{5}{18} + \frac{1}{2} + \frac{4}{9}$ | 32. $\frac{7}{10} + \frac{5}{100} + \frac{3}{1000}$ |
| 12. $\frac{5}{6} + \frac{2}{3}$ | 23. $\frac{2}{5} + \frac{3}{10} + \frac{3}{20}$ | 33. $6 + \frac{1}{100} + \frac{3}{10}$ |
| 13. $\frac{7}{9} + \frac{3}{5}$ | 24. $\frac{2}{7} + \frac{4}{21} + \frac{1}{3}$ | 34. $5 + \frac{13}{100} + \frac{7}{10}$ |
| 14. $\frac{5}{6} + \frac{2}{7}$ | | |

Subtract and reduce to lowest terms. See Examples 6 through 8.

- | | | |
|-------------------------------------|-----------------------------------|--|
| 35. $\frac{9}{10} - \frac{3}{10}$ | 43. $\frac{1}{16} - \frac{3}{8}$ | 51. $\frac{5}{4} - \frac{3}{5}$ |
| 36. $\frac{7}{8} - \frac{5}{8}$ | 44. $\frac{2}{3} - \frac{7}{6}$ | 52. $\frac{2}{3} - \frac{2}{7}$ |
| 37. $\frac{11}{12} - \frac{7}{12}$ | 45. $\frac{8}{10} - \frac{3}{15}$ | 53. $-\frac{5}{12} - \left(-\frac{1}{6}\right)$ |
| 38. $\frac{21}{15} - \frac{11}{15}$ | 46. $\frac{9}{14} - \frac{2}{21}$ | 54. $-\frac{31}{40} - \left(-\frac{5}{8}\right)$ |
| 39. $-\frac{5}{9} - \frac{1}{9}$ | 47. $\frac{3}{4} - \frac{2}{3}$ | 55. $1 - \frac{9}{10}$ |
| 40. $-\frac{4}{11} - \frac{6}{11}$ | 48. $\frac{2}{3} - \frac{1}{4}$ | 56. $1 - \frac{1}{16}$ |
| 41. $\frac{5}{6} - \frac{1}{3}$ | 49. $\frac{3}{8} - \frac{1}{16}$ | 57. $2 - \frac{9}{16}$ |
| 42. $\frac{5}{6} - \frac{1}{2}$ | 50. $\frac{7}{6} - \frac{2}{3}$ | 58. $6 - \frac{2}{3}$ |

59. $\frac{14}{35} - \frac{12}{30}$

61. $\frac{76}{100} - \frac{7}{10}$

63. $\frac{1}{10} - \frac{8}{100}$

60. $\frac{20}{35} - \frac{24}{42}$

62. $\frac{54}{100} - \frac{5}{10}$

64. $\frac{3}{100} - \frac{1}{1000}$

Applications

Solve.

65. Three pieces of mail weigh $\frac{1}{2}$ ounce, $\frac{1}{5}$ ounce, and $\frac{3}{10}$ ounce. What is the total weight of the letters?
66. Using a microscope, a scientist measures the diameters of three hairs to be $\frac{1}{1000}$ inch, $\frac{3}{1000}$ inch, and $\frac{1}{100}$ inch. What is the total of these three diameters?
67. A machinist drills four holes in a straight line. Each hole has a diameter of $\frac{1}{10}$ inch and there is $\frac{1}{4}$ inch between the holes. What is the distance between the outer edges of the first and last holes?
68. A notebook contains a piece of cardboard as a back cover that is $\frac{1}{16}$ inch thick. It has a front cover that is $\frac{1}{4}$ inch thick. All together, the sheets of paper between the front and back are $\frac{3}{10}$ inch thick. What is the total thickness of the notebook?
69. A carpenter is installing baseboard and toe molding. If the baseboard is $\frac{3}{8}$ inch thick and the toe molding (to be put in front of the baseboard) is $\frac{1}{4}$ inch thick, what is the total thickness of the two trim pieces?
70. A recipe calls for the following spices: $\frac{1}{2}$ teaspoon of turmeric, $\frac{1}{4}$ teaspoon of ginger, and $\frac{1}{8}$ teaspoon of cumin. What is the total quantity of these three spices?
71. Beth's investment strategy is to put $\frac{1}{6}$ of her paycheck into a savings account and another $\frac{1}{9}$ into a retirement account.
- What fraction of her salary does Beth invest each month?
 - If she maintains this strategy for 24 paychecks and receives \$900 per paycheck, how much money will she have saved?
72. John has a monthly income of \$3000. $\frac{1}{10}$ of it goes to college savings, $\frac{2}{15}$ to general savings, and $\frac{1}{12}$ to retirement.
- What fraction of John's income is being saved?
 - How much money is being saved each month?
 - What is the total amount saved in a 12-month year?
73. A $\frac{7}{8}$ inch pipe is to be shortened to $\frac{7}{12}$ inch. How much must be removed?
74. Near the end of the snow season, the road salt supply for a small college had dwindled down to $\frac{7}{10}$ ton. When the next snow storm came, $\frac{1}{2}$ ton of salt was used for the roads. How much road salt was left?

75. Mark has driven to a national park with no gas stations and he wants to drive around some before leaving the park. He knows he can safely make it to the nearest gas station on $\frac{1}{4}$ of a tank of gas. If the tank is currently $\frac{5}{9}$ full, what fraction of a tank of gasoline does he have to use for touring the park?
76. About $\frac{1}{2}$ of all incoming solar radiation is absorbed by the earth, $\frac{1}{5}$ is absorbed by the atmosphere, and $\frac{1}{20}$ is scattered by the atmosphere. The rest is reflected by the earth and clouds.
- What fraction of solar radiation is absorbed or scattered?
 - What fraction of solar radiation is reflected by the earth and clouds?
77. Jenny has $\frac{3}{4}$ of an apple pie left over from a party last night. Her roommates found it and cut themselves three unequal sized pieces in the following amounts: $\frac{1}{3}$ of a pie, $\frac{1}{4}$ of a pie, and $\frac{1}{6}$ of a pie.
- What fraction of a full pie did Jenny's roommates take?
 - What fraction of the pie is left over?
78. A moving truck has to make stops at three different apartments to collect items for three different moves. The first apartment takes up $\frac{3}{7}$ of the truck and the second apartment takes up $\frac{3}{14}$ of the truck. What fraction of the space in the moving truck is left to fit in the items from the last apartment?
79. Josh has a large homework assignment to do this weekend. He is able to get $\frac{4}{15}$ of the assignment done Friday after class. If he doesn't want to leave more than $\frac{2}{9}$ of the assignment to do for Sunday, what fraction of the assignment must he complete on Saturday?
80. A pentagon (a five-sided figure) has 4 sides of length $\frac{1}{3}$, $\frac{1}{4}$, $\frac{1}{5}$, and $\frac{1}{6}$ inches. If the perimeter of the pentagon is 1 inch, find the length of the fifth side.

Writing & Thinking

- Explain how finding the LCM relates to LCDs.
- Explain the steps to follow when adding or subtracting fractions with unlike denominators
- Give an example of a situation where you might add or subtract fractions (other than in class).
- Pick one problem in this section that gave you some difficulty. Explain briefly why you had difficulty and why you think that you can better solve problems of this type in the future.

Example 8 Rounding Decimal Numbers

Round 5.83971 to the nearest thousandth.

Solution

9 is in the thousandths place.



The next digit to the right is 7.

Since 7 is greater than 5, increase 9 by one and replace 7 and 1 with 0s. (Increasing 9 by one gives 10, which affects the digit 3 as well.)

Thus, 5.83971 rounds to 5.840 to the nearest thousandth, and only two 0s are dropped. Notice that the digit 3 changed to a 4 since the 9 was made one larger during rounding.

Now work margin exercise 8.**Completion Example 9 Rounding Decimal Numbers**

Round 0.6753 to the nearest hundredth.

Solution

The digit in the hundredths position is _____.

The next digit to the right is _____.

Since _____ is equal to 5, change the _____ to _____ and replace _____ and _____ with 0s.

So, 0.6753 rounds to _____ to the nearest hundredth (with two 0s dropped).

Now work margin exercise 9.**Completion Example Answers**

9. The digit in the hundredths position is 7; The next digit to the right is 5; Since 5 is equal to 5, change the 7 to 8 and replace 5 and 3 with 0s; 0.6753 rounds to 0.68

Margin Exercise Answers

1. 19.3; nineteen and three tenths 2. 39.0184; thirty-nine and one hundred eighty-four ten-thousandths 3. a. 1200.0005 b. 0.1205 4. 6.44 5. 9.251 6. -5.3 7. 9.3 8. 5.10 9. 2.395

8. Round 5.0983 to the nearest hundredth.

9. Round 2.3953 to the nearest thousandth.

1.5 Exercises

Concept Check

Fill-in-the-Blank. Complete each sentence using information found in this section.

- When reading or writing decimal numbers, the decimal point is represented by the word _____.
- The place value three places to the right of the decimal is the _____ place.

3. 2.08 would be written as _____ and _____.
4. To compare two decimal numbers, move from left to right and compare digits with the same _____.
5. When rounding, all zeros to the _____ of the decimal point can be dropped, unless they are needed to emphasize (or show) the place of accuracy.
6. When rounding decimal numbers, look at the digit to the _____ of the place of accuracy to determine if the digit in the place of accuracy should remain the same or increase by 1.

True/False. Determine whether each statement is true or false. If a statement is false, explain how it can be changed so the statement will be true. (**Note:** There may be more than one acceptable change.)

7. Two hundred thousand, four hundred six and twelve hundredths can be written as 200,406.12.
8. 92.586 is greater than 92.6.
9. On a number line, any number to the left of another number is larger than that other number.
10. When a decimal number is rounded, all numbers to the right of the place of accuracy become zeros in the final answer.

Practice

Write each mixed number in decimal notation. See Examples 1 and 2.

- | | |
|-----------------------|-------------------------|
| 1. $6\frac{5}{10}$ | 6. $13\frac{2}{100}$ |
| 2. $8\frac{4}{10}$ | 7. $37\frac{498}{1000}$ |
| 3. $18\frac{76}{100}$ | 8. $62\frac{547}{1000}$ |
| 4. $2\frac{57}{100}$ | 9. $87\frac{3}{1000}$ |
| 5. $56\frac{3}{100}$ | 10. $12\frac{37}{1000}$ |

Write each decimal number in words. See Examples 1 and 2.

- | | |
|----------|-------------|
| 11. 0.9 | 16. 2.79 |
| 12. 0.5 | 17. 19.102 |
| 13. 20.7 | 18. 18.051 |
| 14. 96.3 | 19. 800.009 |
| 15. 1.53 | 20. 500.005 |

Write each number in decimal notation. See Example 3.

- | | |
|---|--|
| 21. three tenths | 27. six and twenty-eight thousandths |
| 22. seven tenths | 28. fourteen and ninety-seven thousandths |
| 23. seventeen and nine tenths | 29. four thousand five hundred two ten-thousandths |
| 24. eight hundred and three tenths | 30. seven thousand one hundred sixty-five ten-thousandths |
| 25. twenty-three hundredths | |
| 26. seventy-two hundredths | |

For each pair of decimal numbers, determine which number is larger. See Examples 4 and 5.

- | | |
|-------------------------|-----------------------------|
| 31. 0.26, 0.27 | 35. 23.521, 24.295 |
| 32. 0.45, 0.48 | 36. 110.241, 101.862 |
| 33. 0.153, 0.163 | 37. 0.01, 0.009 |
| 34. 4.537, 4.527 | 38. 4.002, 4.0008 |

Arrange each set of decimal numbers in order from smallest to largest. Then graph the numbers on a number line. See Example 5.

- | | |
|----------------------------|---------------------------------------|
| 39. 0.3, 0.03, 0.33 | 42. 1.8, 1.75, 1.86 |
| 40. 0.55, 0.05, 0.5 | 43. 0.157, 0.2611, 0.192, 0.26 |
| 41. 0.2, 0.26, 0.17 | 44. 1.432, 1.54, 1.14, 1.5422 |

Fill in the blanks to correctly complete each statement. See Examples 7 through 9.

- 45.** Round 34.78 to the nearest tenth.
- The digit in the tenths position is ____.
 - The next digit to the right is ____.
 - Since ____ is greater than 5, change ____ to ____ and replace ____ with 0.
 - So 34.78 rounds to ____ to the nearest tenth.
- 46.** Round 70.53 to the nearest tenth.
- The digit in the tenths position is ____.
 - The next digit to the right is ____.
 - Since ____ is less than 5, leave ____ as it is and replace ____ with 0.
 - So 70.53 rounds to ____ to the nearest tenth.
- 47.** Round 3.00652 to the nearest ten-thousandth.
- The digit in the ten-thousandths position is ____.
 - The next digit to the right is ____.
 - Since ____ is less than 5, leave ____ as it is and replace ____ with 0.
 - So 3.00652 rounds to ____ to the nearest ten-thousandth.

- 48.** Round 8.00516 to the nearest ten-thousandth.
- The digit in the ten-thousandths position is ____.
 - The next digit to the right is ____.
 - Since ____ is greater than 5, change ____ to ____ and replace ____ with 0.
 - So 8.00516 rounds to _____ to the nearest ten-thousandth.

Round each decimal number to the nearest tenth. See Example 7.

-
- 49.** 8.555 **50.** 3.251 **51.** 9.961 **52.** 4.980

Round each decimal number to the nearest hundredth. See Example 9.

-
- 53.** 1.677 **54.** 19.444 **55.** 0.0764 **56.** 0.0439

Round each decimal number to the nearest thousandth. See Example 8.

-
- 57.** 0.0572 **58.** 0.6388 **59.** 3.00254 **60.** 19.01655

Round each decimal number to the nearest whole number (or nearest unit).

-
- 61.** 4.41 **62.** 8.73 **63.** 29.999 **64.** 19.888

Round each decimal number to the nearest hundred.

-
- 65.** 5163 **66.** 6475 **67.** 435.7 **68.** 263.9

Round each decimal number to the nearest thousand.

-
- 69.** 103,499 **70.** 37,495 **71.** 50,766.4 **72.** 40,397.9

Applications

In each exercise, write the decimal numbers that are not whole numbers in words.

-
- 73.** The tallest unicycle ever ridden was 114.8 feet tall, and was ridden by Sam Abrahams (with a safety wire suspended from an overhead crane) for a distance of 28 feet in Pontiac, Michigan, on January 29, 2004.¹
- 74.** A penny dated from 1959 through 1982 had an original weight of 3.11 grams. A penny dated 1983 or later had an original weight of 2.5 grams.
- 75.** One yard is equal to 36 inches. One yard is also approximately equal to 0.914 meter. One meter is approximately equal to 1.09 yards. One meter is also approximately equal to 39.37 inches. (Thus, a meter is longer than a yard by about 3.37 inches.)
- 76.** One foot is equal to 12 inches. One foot is also equal to 30.48 centimeters. One square foot is approximately 0.093 square meters.
- 77.** One quart of water weighs approximately 2.0825 pounds.
- 78.** The number π is approximately equal to 3.14159.
- 79.** Euler's number e is approximately equal to 2.71828.

¹ Source: semicycle.biz/record

80. The largest state in the United States is Alaska, which covers approximately 656.4 thousand square miles. The second largest state is Texas, which covers approximately 268.6 thousand square miles. Alaska is more than 10 times the size of Wisconsin (twenty-third in size), which covers about 65.5 thousand square miles.
81. A few track world records are as follows: 9.58 seconds for 100 meters (by Usain Bolt, Jamaica, 2009); 19.19 seconds for 200 meters (by Usain Bolt, Jamaica, 2009); 43.03 seconds for 400 meters (by Wayde van Niekerk, South Africa, 2016).²
82. The mean distance from the Sun to Earth is about 92.9 million miles and from the Sun to Venus is 67.24 million miles. One period of revolution of the Earth about the Sun takes 365.2 days, and one period of revolution of Venus about the sun takes 224.7 days.
83. An interesting fact about aging is that the longer you live, the longer you can expect to live. A white male of age 40 can expect to live 35.8 more years; of age 50, can expect to live 26.9 more years; of age 60 can expect to live 18.9 more years; of age 70 can expect to live 12.3 more years; and of age 80 can expect to live 7.2 more years. (This same phenomenon is true of men and women of all races.)

Writing & Thinking

84. In your own words, state why the word “and” is so commonly misused when numbers are spoken and/or written. Bring an example of this from a newspaper, magazine, or television show to share with the class.
85. Suppose you are writing a check to pay your phone bill. How would you write the amount due in standard notation and in English word form?
86. Discuss situations where you think it is particularly appropriate (or necessary) to write numbers in English word form.
87. Using parts a. and b. as examples, explain in your own words how you can tell quickly when one decimal number is larger (or smaller) than another decimal number.
 - a. The decimal number 2.765274 is larger than the decimal number 2.763895.
 - b. The decimal number 17.345678 is larger than the decimal number 17.345578.

2 Source: trackandfieldnews.com/records/mens-world-records

Solution

$$\begin{aligned}
 &3.1^2 + 7.05 \div 1.5 \\
 &= 9.61 + 7.05 \div 1.5 && \text{Evaluate the exponential expression.} \\
 &= 9.61 + 4.7 && \text{Divide.} \\
 &= 14.31 && \text{Add.}
 \end{aligned}$$

Now work margin exercise 8.

9. Simplify:

$$3.2(0.5^2 + 1.1) - 7.3$$

Example 9 Using the Order of Operations with Decimal Numbers

$$\text{Simplify: } 2.1(-45.2 + 10.8) - 15.38$$

Solution

$$\begin{aligned}
 &2.1(-45.2 + 10.8) - 15.38 \\
 &= 2.1(-34.4) - 15.38 && \text{Subtract inside the parentheses.} \\
 &= -72.24 - 15.38 && \text{Multiply.} \\
 &= -87.62 && \text{Subtract.}
 \end{aligned}$$

Now work margin exercise 9.**Margin Exercise Answers**

1. 42.0667 2. 5.891 3. \$8.68 4. 16.0146 5. 18.72 6. 14.9 7. 8 meters per second 8. 7.28
9. -2.98

1.6 Exercises

Concept Check

Fill-in-the-Blank. Complete each sentence using information found in this section.

- When adding or subtracting decimal numbers, keep the decimal points aligned _____.
- When adding or subtracting, to help keep corresponding digits aligned, _____ may be written in place of missing place values.
- Once the numbers and decimal points have been aligned, addition or subtraction can be performed the same as with _____ numbers.
- The first step in multiplying decimal numbers is to multiply the two numbers as if they were _____.
- If the decimal point is moved 3 places to the right in the divisor, then the decimal point in the _____ must also be moved 3 places to the right.

True/False. Determine whether each statement is true or false. If a statement is false, explain how it can be changed so the statement will be true. (**Note:** There may be more than one acceptable change.)

6. In subtracting decimal numbers, line up all the last digits vertically.
7. Once decimal points and corresponding digits have been aligned vertically, add or subtract from left to right.
8. When multiplying decimal numbers, the answer should have the same number of decimal places as the total number of decimal places in the numbers being multiplied.
9. The decimal point should be placed in the quotient before actually dividing.

Practice

Perform the indicated operations. Round any quotient to the nearest hundredth, if necessary.

$$\begin{array}{r} 1. \quad 42.08 \\ + 8.005 \\ \hline \end{array}$$

$$\begin{array}{r} 2. \quad 14.5 \\ + 9.09 \\ \hline \end{array}$$

$$\begin{array}{r} 3. \quad 0.09 \\ 165.1 \\ + 72.55 \\ \hline \end{array}$$

$$\begin{array}{r} 4. \quad 3.8771 \\ 0.307 \\ + 4.0086 \\ \hline \end{array}$$

$$\begin{array}{r} 5. \quad 1.1 \\ 0.32 \\ 2.4 \\ + 6.01 \\ \hline \end{array}$$

$$\begin{array}{r} 6. \quad 3.2 \\ 0.39 \\ 1.004 \\ + 4.205 \\ \hline \end{array}$$

$$\begin{array}{r} 7. \quad 37.02 \\ 25 \\ 6.4 \\ + 3.89 \\ \hline \end{array}$$

$$\begin{array}{r} 8. \quad 5 \\ 2.37 \\ 436 \\ + 10.88 \\ \hline \end{array}$$

$$9. \quad 3.07 + 596$$

$$10. \quad 2.3 + 10.022$$

$$11. \quad 152.3 + 4.005$$

$$12. \quad 22.051 + 0.2006$$

$$13. \quad 2.59 + 16.9 + 0.051$$

$$14. \quad 2.48 + 51.22 + 10.734$$

$$15. \quad 9 + 5.6 + 0.58 + 25.133$$

$$16. \quad 3.766 + 9.33 + 14 + 206$$

$$\begin{array}{r} 17. \quad 39.542 \\ - 28.411 \\ \hline \end{array}$$

$$\begin{array}{r} 18. \quad 46.918 \\ - 31.702 \\ \hline \end{array}$$

$$\begin{array}{r} 19. \quad 87.1 \\ - 69.3 \\ \hline \end{array}$$

$$\begin{array}{r} 20. \quad 63.4 \\ - 27.8 \\ \hline \end{array}$$

21.
$$\begin{array}{r} 51.3 \\ - 6.29 \\ \hline \end{array}$$
22.
$$\begin{array}{r} 72.6 \\ - 8.54 \\ \hline \end{array}$$
23.
$$\begin{array}{r} 4.8 \\ - 0.0026 \\ \hline \end{array}$$
24.
$$\begin{array}{r} 7.6 \\ - 0.0097 \\ \hline \end{array}$$
25. $17.83 - 8.9$
26. $14.59 - 2.8$
27. $5.2 - 3.76$
28. $29.5 - 13.61$
29. $1.0057 - 0.03$
30. $78.015 - 13.06$
31. $18 - 0.4384$
32. $23 - 2.3196$
33. $8.2 + 1.35 + (-22.70)$
34. $77.5 + (-38.1) + 56.3$
35. $-8.45 - 6.98$
36. $-44.7 - 98.61$
37. $-88.6 - (-91.9)$
38. $-4.55 - (-5.25)$
39. $13.4 - 22.7 + 15.6$
40. $167.1 - 290 + 145.3$
41. $2.1 + 8.2 - 1.4 - 3.1$
42. $-8.4 - 3.7 + 2.6 - 0.1$
43. $58 - 63.2 - (-14.21) + 3.5$
44. $-57.11 + 62.9 - 22.78 - (-5.49)$
45. $(0.6)(0.7)$
46. $(0.3)(0.8)$
47. $-6(0.125)$
48. $-2(0.125)$
49. $(1.4)(0.3)$
50. $(1.5)(0.6)$
51. $(5.6)(-0.02)$
52. $(4.8)(-0.06)$
53. $(-5.48)(-0.002)$
54. $(-4.29)(-0.003)$
55. $1.6 \cdot 0.875$
56. $3.2 \cdot 0.375$
57. $-5.3 \cdot 0.75$
58. $-6.9 \cdot 0.25$
59. $4.8 \cdot 0.25$
60. $2.4 \cdot 0.75$
61.
$$\begin{array}{r} 6.884 \\ \times 9.5 \\ \hline \end{array}$$
62.
$$\begin{array}{r} 5.392 \\ \times 6.5 \\ \hline \end{array}$$
63.
$$\begin{array}{r} 0.08 \\ \times 0.542 \\ \hline \end{array}$$
64.
$$\begin{array}{r} 0.833 \\ \times 0.04 \\ \hline \end{array}$$
65. $-1.62 \div 9$
66. $-4.95 \div 5$
67. $0.064 \div (-0.8)$
68. $0.063 \div (-0.7)$
69. $-16.35 \div (-2.5)$
70. $-30.94 \div (-6.5)$

71. $48 \div 2.4$

72. $168 \div 5.6$

73. $\frac{0.1463}{24}$

74. $\frac{0.2249}{23}$

75. $-0.42753 \div (-0.074)$

76. $-0.2433 \div (-0.065)$

77. $1.23 \overline{)14.91129}$

78. $3.14 \overline{)15.25631}$

79. $9 \overline{)5}$

80. $9 \overline{)2}$

81. $1.5^2 - 4.25 \div 0.25$

82. $5.4 \div 1.8 - 2.4^2$

83. $1.52 + 0.56 - 2.2 \cdot 6.5$

84. $12.6 + 5.88 - 13.9 \cdot 6.5$

85. $3.1(50 - 25.8) - 12.9$

86. $4.1(38.6 - 29.8) + 8.6$

87. $40.7 - (2.5^2 + 7.25) \div 0.5$

88. $97.5 + (30.46 - 4.6^2) \div 1.5$

Applications

Solve.

89. Mr. Johnson bought the following items at a department store: slacks, \$32.50; shoes, \$43.75; shirt, \$18.60.
- How much did he spend?
 - What was his change if he gave the clerk a \$100 bill? (Tax was included in the prices.)
90. Theresa got a haircut for \$38.00, a manicure for \$15.50, and left an \$8.00 tip.
- How much did she spend?
 - How much change should she receive from \$70? (Tax was included in the prices.)
91. Suppose your checking account shows a balance of \$253.70 at the beginning of the month. During the month you make deposits of \$635, \$279, and \$428, and you make debit purchases for \$124.60, \$89.55, \$680, and \$29.80. Find the end-of-the-month balance on your account.
92. Suppose your checking account shows a balance of \$382.35 at the beginning of the month. During the month, you make deposits of \$580.00, \$300.00, \$182.50, and \$45.00, and you make debit purchases for \$85.35, \$210.50, \$43.75, and \$650. Find the end-of-the-month balance in your account.
93. A special steel alloy for knife blades consists of iron along with a mixture of other chemical elements. What is the total weight of the “ingredients” if 10 tons of iron is combined with 0.28 ton of carbon, 1.58 ton of chromium, 0.269 ton of vanadium, and 0.0488 ton of manganese? ¹

¹ Source: zknives.com/knives/steels/steelchart.ph

94. A college student is purchasing the necessary textbooks and supplies for an education course, which consist of the textbook for \$144.37, the accompanying lesson plan guide book for \$38.17, and a package of 4 by 6 inch index cards for \$1.79. In addition, she is purchasing a candy bar for \$0.71 and a piece of bubble gum for \$0.06. How much will her total be?
95. A young child has a bunch of change in his pocket, and he wants to purchase a comic book which costs \$2.26. If he has \$1.25 in quarters, \$0.40 in dimes, \$0.35 in nickels, and \$0.07 in pennies, does he have enough money to buy the comic book? If not, how much extra must he get so that he can buy it? (**Hint:** Add up the value of his coin collection. If it exceeds the cost, he has enough money. If not, subtract the cash on hand from the cost of the comic book.)
96. A college student is receiving assistance from two sources, which will be applied to the following expenses: \$17,993.74 for tuition and fees, \$7248.39 for room and board, and \$1537.71 for books and supplies. If one of the sources of assistance supplies \$9438.72 and the other \$8300, how much must the student cover? (**Hint:** Add the total costs, add up the total assistance, and subtract this from the total cost to find how much the student must cover.)
97. To buy a car, you can pay \$2036.50 in cash, or you can put down \$400 and make 18 monthly payments of \$104.30. How much would you save by paying cash?
98. To buy a new washer and dryer, you can pay \$1737.83 in cash, or you can put \$350 down and make 12 monthly payments of \$129.54. How much would you save by paying cash?
99. At one point, Ohio funded its public libraries with \$39.87 spent for each person. How much funding would have been received that year by a library that served a town of 23,500 people?
100. In March of 2022, the average price per kilogram paid by the United States for beef imported from Australia and New Zealand was \$6.25. At this price, what would be the value of 20,500 kilograms of beef?
101. If four new tires with custom rims cost \$958.24, what did each individual tire with rim cost?
102. If you bought 6 books for a total price of \$142.98, what average amount did you pay per book, including tax?
103. If the total price of a stereo was \$312.70 including a tax of 0.06 times the list price, you can find the list price by dividing the total price by 1.06. What was the list price? (**Note:** 1.06 represents the list price plus 0.06 times the list price.)
104. If the total price of a tablet PC was \$266.43 including a tax of 0.07 times the list price, you can find the list price by dividing the total price by 1.07. What was the list price? (**Note:** 1.07 represents the list price plus 0.07 times the list price.)

Writing & Thinking

105. Why is it important that the decimal points and numbers be aligned vertically when adding or subtracting decimals?
106. Suppose you are given two decimal numbers with 0 as their whole number parts.
 - a. Explain why the difference would be less than 1.
 - b. Explain how the difference might be 0.
107. In your own words, discuss the similarities and differences between multiplication with whole numbers and multiplication with decimal numbers.
108. Discuss briefly, situations in which you might use division with decimal numbers in your daily life.

Step 3: SOLVE: Change $2\frac{1}{2}$ to decimal form ($2\frac{1}{2} = 2.5$) and multiply by \$35.60.

$$\begin{array}{r} \$ 35.60 \\ \times \quad 2.5 \\ \hline 17800 \\ 71200 \\ \hline \$ 89.000 \end{array} \quad \text{Charge for labor}$$

Now add the cost of the parts to the cost of labor.

$$\begin{array}{r} ^1 ^1 \\ \$ 89.00 \quad \text{Cost of labor} \\ + \$ 273.49 \quad \text{Cost of parts} \\ \hline \$ 362.49 \quad \text{Total charge for job} \end{array}$$

The total charge for the job would be \$362.49.

Step 4: CHECK: The cost of labor per hour is approximately \$40. This means that $2\frac{1}{2}$ hours of labor will cost approximately \$100. Considering that the parts alone cost \$273.49, the answer of \$362.49 seems reasonable.

Now work margin exercise 12.

Margin Exercise Answers

1. a. $\frac{12}{25}$ b. $\frac{19}{20}$ 2. a. $\frac{763}{1000}$ b. $-\frac{4}{125}$ 3. $15\frac{4}{5}$ 4. 0.4 5. -1.65 6. 0.13333...
 7. 0.230769230769... 8. 17.03 9. $\frac{9}{16}$ is larger than 0.52 by 0.0425 10. -0.07125 11. -6.15
 12. \$11.97

1.7 Exercises

Concept Check

Fill-in-the-Blank. Complete each sentence using information found in this section.

- To change a decimal number to a fraction, use the digits of the decimal number as the _____ and a power of 10 as the _____.
- To change a decimal number to a fraction, find the power of 10 that names the position of the rightmost digit as the _____.
- Nonterminating decimal numbers can be categorized as either _____ or _____ decimal numbers.
- To change a fraction to a decimal number, divide the _____ by the _____.
- In decimal form, $\frac{3}{5}$ is a/an _____ decimal number.
- When computing problems with both fractions and decimal numbers, sometimes all numbers need to be in _____ form to preserve accuracy.

True/False. Determine whether each statement is true or false. If a statement is false, explain how it can be changed so the statement will be true. (**Note:** There may be more than one acceptable change.)

-
7. When a decimal number is changed to a fraction, the denominator will be the power of 10 that names the rightmost digit of the decimal number.
 8. When a decimal number is changed to a fraction, the numerator can be determined by using the whole number that is formed by all the digits of the decimal number.
 9. Fractions can always be converted to decimal form without losing accuracy.
 10. In decimal form, $\frac{1}{3}$ is repeating and nonterminating.

Practice

Change each decimal number to a fraction. Do not reduce.

-
- | | | |
|----------|----------|----------|
| 1. 0.9 | 4. -0.41 | 7. -7.2 |
| 2. 0.3 | 5. 0.016 | 8. -19.5 |
| 3. -0.57 | 6. 0.012 | |

Change each decimal number to a fraction or mixed number in lowest terms. See Examples 1 through 3.

-
- | | | |
|-----------|-----------|----------|
| 9. -0.17 | 12. 0.375 | 15. 1.77 |
| 10. -0.23 | 13. -3.5 | 16. 4.31 |
| 11. 0.125 | 14. -1.25 | |

Change each fraction to a decimal number. If the decimal number is nonterminating, write it using a bar over the repeating pattern of digits. See Examples 4 through 7.

-
- | | | |
|--------------------|---------------------|-------------------|
| 17. $\frac{1}{20}$ | 20. $-\frac{1}{6}$ | 23. $\frac{3}{7}$ |
| 18. $\frac{1}{25}$ | 21. $-\frac{5}{18}$ | 24. $\frac{5}{7}$ |
| 19. $-\frac{2}{3}$ | 22. $-\frac{5}{12}$ | |

Change each fraction to a decimal number rounded to the nearest hundredth. See Example 6.

-
- | | | |
|----------------------|----------------------|----------------------|
| 25. $\frac{20}{3}$ | 28. $-\frac{15}{22}$ | 31. $-\frac{30}{21}$ |
| 26. $\frac{40}{9}$ | 29. $\frac{1}{32}$ | 32. $-\frac{16}{13}$ |
| 27. $-\frac{16}{33}$ | 30. $\frac{1}{14}$ | |

Simplify each expression by writing all of the numbers in decimal form and performing the indicated operations. Round to the nearest hundredth, if necessary. See Example 8

33. $\frac{5}{8} + \frac{3}{5} + 0.41$

39. $2\frac{1}{10} - 3.1$

46. $-9.17 \div \frac{1}{4}$

34. $\frac{2}{5} + \frac{3}{8} + 1.24$

40. $23\frac{1}{5} - 36.2$

47. $5\frac{54}{100} \div 2.1$

35. $37.02 + 25 + 6\frac{2}{5}$
 $+ 3\frac{89}{100}$

41. $\left(\frac{35}{100}\right)^2 (0.73)$

48. $3\frac{26}{100} \div 1.5$

36. $14.9 + 22 + 4\frac{3}{4}$
 $+ 9\frac{73}{100}$

42. $\left(\frac{3}{10}\right)^2 (0.63)$

49. $\left|-3\frac{3}{4}\right| - |21.3|$

37. $1\frac{1}{4} - 0.125$

43. $\left(-1\frac{3}{8}\right)(2.1)(3.6)$

50. $\left|22\frac{4}{5}\right| + |-5.8|$

38. $2\frac{4}{5} - 1.75$

44. $\left(2\frac{1}{4}\right)\left(-3\frac{1}{2}\right)(4.1)$

51. $\left|-5\frac{1}{2}\right| + \left|3\frac{1}{2}\right|$
 $- |-10.7|$

45. $-72.186 \div \frac{3}{5}$

52. $|-4.72| \div \frac{8}{9}$

For each pair of numbers, determine which number is larger. Then, determine the difference between the two numbers. (If the difference is a nonterminating number, write it using a bar over the repeating pattern of digits.) See Example 9.

53. $\frac{7}{8}, 0.878$

55. $\frac{22}{7}, 3.3$

57. $3.5, 3\frac{2}{3}$

54. $2\frac{1}{4}, 2.3$

56. $\frac{4}{9}, 0.5$

58. $5\frac{3}{4}, 5.5$

Arrange each set of numbers in order from smallest to largest.

59. $0.76, \frac{3}{4}, \frac{7}{10}$

61. $\frac{5}{16}, 0.3126, 0.314$

60. $0.63, \frac{5}{8}, 0.64$

62. $0.083, \frac{41}{500}, \frac{2}{25}$

Evaluate each expressions for $x = 1.5 = \frac{3}{2}$ and $y = \frac{2}{3}$. Leave the answers in fraction or mixed number form. (Do not use $\frac{2}{3}$ in decimal form because you will get only an approximate answer.) See Example 11.

63. $2x^2 - x - 3$

65. $xy^3 - xy$

67. $x^3 + 3x^2 + 3x + 1$

64. $3y^2 - 5y + 2$

66. $x^2y^2 + 2xy - 5$

68. $x^2 + 6xy + 9y^2$

Applications

Change any decimal number (that is not a whole number) to a fraction or mixed number.

69. By 2020 census estimates, there were 93.8 people per square mile in the United States.
70. A gallon of milk weighs 8.6 lb.
71. The median age for men at the beginning of their first marriage is 30.3 years. The median age for women at the beginning of their first marriage is 28.4 years.
72. The maximum speed of a giant tortoise on land is about 0.17 mph.
73. There are about 21.5 students per teacher in a public school.
74. The surface gravity on Mars is about 0.38 times the gravity on Earth. The atmospheric pressure on Mars is about 0.01 times the atmospheric pressure on Earth.

Change any fraction or mixed number (that is not a whole number) to a decimal number. Round each number to the nearest hundredth.

75. In 2022, it was estimated that the average American adult spent $\frac{7}{12}$ of the time spent on their phone on social media.
76. In a recent year about $\frac{8}{57}$ of the advertising budget in the automotive industry was spent on newspaper ads.
77. In 2016, the average price of unleaded gasoline in California was $2\frac{9}{10}$ times the price it was in 1970.
78. The expected winner of a student senate presidential election only received $\frac{21}{46}$ of the votes.

Solve.

79. A rectangle has a length of 6.4 inches and a width that is $\frac{2}{5}$ times the length. Find the perimeter of the rectangle.
80. A coffee cup holds $14\frac{1}{3}$ ounces of coffee. If each ounce of a certain brewed coffee contains 8.5 mg of caffeine, how much caffeine is in one of these cups of coffee (round to the nearest tenth of a mg)?
81. During five days this week, Mark ran 3.2 miles, $2\frac{3}{4}$ miles, 5.1 miles, $7\frac{1}{3}$ miles, and 1.8 miles. Find the total distance that Mark ran this week, to the nearest tenth of a mile.
82. Sarah and Iygen are working on a physics lab together. They each take measurements of three different timed experiments. Sarah has an analog stop watch and clocks experimental times of $5\frac{1}{8}$, $4\frac{3}{4}$, and $5\frac{1}{2}$ seconds. Iygen has a digital stop watch and clocks experimental times of 5.2, 4.6, and 5.3 seconds. Use all 6 times to determine the average time for all of the experiments, to the nearest tenth.

83. Summerville High School has 3375 students, $\frac{2}{3}$ of whom drive to school. Of the students who drive to school, 0.24 of them have an after-school job. Exactly $\frac{1}{9}$ of the students who drive to school and have a job are taking AP English. How many students who drive to school and have a job are taking AP English?
84. A preschool provides peanut butter sandwiches for each of its 45 children once per week. If each child receives $\frac{8}{5}$ ounces of peanut butter on a sandwich, and peanut butter costs \$3.16 per pound (16 ounces), how much does the preschool spend per week on peanut butter?
85. A loaf of bread weighs 21.6 ounces. Mauricio cut off a third of the loaf to save for later and then cut the remaining portion into 16 equal slices. What was the weight of each slice of the 16 slices he cut?
86. A husband and wife join three single friends for dinner at a Mexican restaurant. Because they shared some appetizers and many entrees are the same price, the five of them decided to simply split the bill five ways. The husband and wife will pay for theirs together. If the total bill was \$62.75, determine how much the husband and wife owe towards the total bill.
87. Janet and Marion are performing an experiment. They each examine 50 slides of viruses for signs of activity. After the examination, Janet reported that $\frac{1}{5}$ of her slides were active and Marion found that 0.3 of her slides were active. How many total slides showed signs of active viruses?
88. A pound of roasted cashews costs \$13.50 and a pound of roasted peanuts costs \$5.25. How much will it cost to purchase $2\frac{1}{2}$ pounds of cashews and $1\frac{1}{3}$ pounds of peanuts?

Writing & Thinking

89. Describe the process used to change a terminating decimal number to a fraction.
90. Do you find it is easier to convert decimal numbers into fractions or fractions into decimal numbers? Explain why.
91. List 2 different ways to solve this problem: $\frac{1}{2} + 3.67 - \frac{1}{8}$. State which method you prefer and why.

Completion Example Answers

7. 100%; 3.60, 360%

Margin Example Answers

1. a. 9% b. 1.25% c. 125% d. 62% e. 0% 2. a. 0.35% b. 217% c. 87.1% d. 10%

3. a. 0.40 b. 2.11 c. 0.006 d. 0.2937 e. 1.02 4. 81.25% 5. 54% 6. 150%

7. 280% 8. 27.3% 9. 93.3% 10. $\frac{4}{5}$ 11. $2\frac{7}{20}$

1.8 Exercises

Concept Check

Fill-in-the-Blank. Complete each sentence using information found in this section.

- Percent is the ratio of a number to _____.
- To change a decimal number to a percent, move the decimal point _____ places to the _____.
- To change a percent to a decimal number, move the decimal point _____ places to the _____.
- If a fraction does not have a denominator that is a factor of 100, it can still be changed to a percent by finding its equivalent _____ number form.
- Anytime a percent is converted to a fraction, the fraction should be _____ if possible.
- To change a percent to a fraction, begin by removing the percent sign and writing the percent as a numerator over _____.

True/False. Determine whether each statement is true or false. If a statement is false, explain how it can be changed so the statement will be true. (**Note:** There may be more than one acceptable change.)

- It is not possible to have a percent greater than 100%.
- A decimal number that is between 0.01 and 0.10 is between 10% and 100%.
- To change from a percent to a decimal, simply omit the percent sign.
- Fractions that have denominators other than 100 cannot be changed to a percent.

Practice

Find the percent of each square that is shaded.

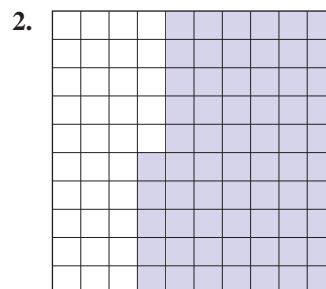
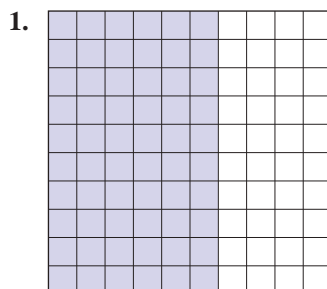

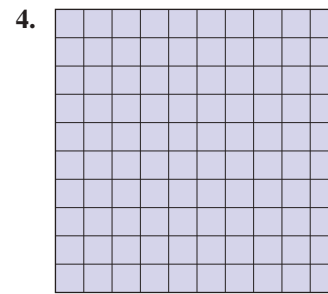
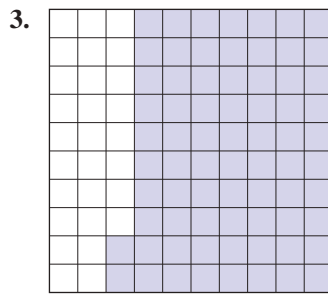

Change each fraction to a percent. See Example 1.

5. $\frac{20}{100}$

7. $\frac{125}{100}$

9. $\frac{0.5}{100}$

11. $\frac{2.14}{100}$

6. $\frac{80}{100}$

8. $\frac{336}{100}$

10. $\frac{0.2}{100}$

12. $\frac{1.62}{100}$

Change each decimal number to a percent. See Example 2.

13. 0.02

16. 0.7

19. 0.128

22. 1.75

14. 0.09

17. 0.36

20. 0.368

23. 2

15. 0.1

18. 0.52

21. 1.12

24. 25

Change each percent to a decimal number. See Example 3.

25. 2%

28. 42%

31. 125%

34. 10.1%

26. 7%

29. 60%

32. 120%

35. 0.26%

27. 18%

30. 30%

33. 17.3%

36. 0.52%

Change each fraction or mixed number to a percent. If necessary, round to the nearest tenth of a percent. See Examples 4 through 8.

37. $\frac{7}{100}$

41. $\frac{11}{20}$

45. $\frac{1}{8}$

49. $2\frac{1}{10}$

38. $\frac{16}{100}$

42. $\frac{4}{5}$

46. $\frac{7}{12}$

50. $5\frac{3}{10}$

39. $\frac{1}{2}$

43. $\frac{56}{64}$

47. $1\frac{1}{4}$

51. $2\frac{1}{15}$

40. $\frac{1}{4}$

44. $\frac{35}{56}$

48. $1\frac{1}{20}$

52. $4\frac{1}{18}$

Change each percent to a fraction or mixed number and reduce, if possible. See Examples 10 and 11.

53. 4%

58. 300%

63. $\frac{1}{2}\%$

66. $37\frac{1}{2}\%$

54. 15%

59. 150%

64. $\frac{1}{4}\%$

67. $16\frac{2}{3}\%$

55. 25%

60. 125%

65. $12\frac{1}{2}\%$

68. $83\frac{1}{3}\%$

57. 100%

62. 0.2%

Find the missing forms of each number.

| | Fraction form | Decimal form | Percent form |
|-----|-----------------|--------------|--------------|
| 69. | $\frac{5}{8}$ | _____ | _____ |
| 70. | $\frac{11}{20}$ | _____ | _____ |
| 71. | _____ | 0.09 | _____ |
| 72. | _____ | 1.75 | _____ |
| 73. | _____ | _____ | 36% |
| 74. | _____ | _____ | 10.5% |

Applications

Solve.

75. To calculate what your maximum house payment should be, a banker multiplied your income by 0.28. Change 0.28 to a percent.
76. The discount you earn by paying cash is found by multiplying the amount of your purchase by 0.02. Change 0.02 to a percent.
77. A savings account is offering an interest rate of 0.04 for the first year after opening the account. Change 0.04 to a percent.
78. Suppose the state license fee is figured by multiplying the cost of your car by 0.065. Change 0.065 to a percent.
79. The sales commission for the clerk at a retail store is figured at 8.5%. Change 8.5% to a decimal.
80. Suppose that sales tax is figured at 7.25%. Change 7.25% to a decimal.
81. At Mr. Jones' sporting goods store, the rate of profit based on sales price is 45%. Change 45% to a decimal.
82. The discount during a special sale on dresses is 30%. Change 30% to a decimal.
83. According to the last US Census, per capita property taxes in New Jersey were 523% higher than those in Alabama. Write 523% as a decimal.
84. According to the Aluminum Association, the percentage of aluminum cans recycled in 2015 was 64.3%, and this percentage fell to 63.6% in 2018. Write 64.3% and 63.6% as decimals.
85. A department store offers a 30% discount during a special sale on men's suits. Change 30% to a fraction reduced to lowest terms.

86. Betty pays income tax of 24% on her pay from working as a labor and delivery nurse. Express 24% as a fraction reduced to lowest terms.
87. The portfolio of an investor increased by 385%. Express this as a mixed number reduced to lowest terms.
88. A certain very precise voltmeter will measure the voltage with no greater than 0.035% error. This means that the difference between the actual voltage and the indicated voltage is no greater than 0.035% of the measured voltage; this is expressed as $\pm 0.035\%$. Express this maximum error as a fraction reduced to lowest terms.
89. Consider each measurement.
- There are 12 inches in a foot. What percent of a foot is an inch?
 - There are 4 quarts in a gallon. What percent of a gallon is a quart?
 - There are 16 ounces in a pound. What percent of a pound is an ounce?
90. In a sophomore class of 250 students, 10 students represent the sophomore class on the student council. What percent of the class is on the student council?
91. Out of a possible total of 240 points on an exam, David received 204 points. What percent of the exam did David get correct?
92. Three gallons of fluoride are in a 4,000,000 gallon supply of drinking water. What percent of the drinking water is fluoride?
93. According to the laws in the United States, a person can be arrested for driving under the influence of alcohol if the blood alcohol concentration (BAC) is 0.08% or greater, where BAC in decimal form is defined as the number of grams of alcohol in 1 milliliter of blood.¹
- Assume that 2 milliliters of blood has 0.0022 grams of alcohol, what is the BAC in decimal units? (**Hint:** Divide the amount of alcohol by the amount of blood.)
 - Express this as a percent.
 - Does this exceed the legal limit of 0.08%?
94. In 2020, approximately 88,000,000 Americans were between the ages of 25 and 44. If the total US population was approximately 329,000,000 people, what percentage (to the nearest percent) of the population is between the ages of 25 and 44?²
95. A recipe to create self-rising flour says to mix 120 grams of all-purpose flour with 5 grams of salt and 8 grams of baking powder. The salt and baking powder mixture make up what percent of the self-rising flour? Round your answer to the nearest tenth of a percent.

1 Source: dui.drivinglaws.org/drink-table.php

2 www.statista.com/statistics/241488/population-of-the-us-by-sex-and-age/

96. A sample of perfume is made with 21 drops of peach oil, 35 drops of rosemary oil, and 14 drops of sandalwood oil. The oil mixture is then diluted with 100 drops of perfumer's alcohol. Round your answers to the nearest tenth of a percent. (**Hint:** The denominator is equal to the total number of drops that make up the perfume.)
- What percent of the perfume sample does the rosemary make up?
 - The perfumer's alcohol makes up what percent of the perfume sample?
 - The oil mixture makes up what percent of the perfume sample?

Writing & Thinking

97. Describe a situation where more than 100% is possible. Describe a situation where it is impossible to have more than 100%.
98. Compare and contrast the process for converting percents to decimal numbers and changing decimal numbers to percents.
99. Justify why mixed numbers are a larger percentage than proper fractions alone. (Consider the value of 100%.)

Margin Exercise Answers

1. 85 ft 2. 69.08 m 3. 24.28 ft 4. 28 mm² 5. 28.26 ft² 6. a. 120 yd b. 900 yd² 7. 810 in.²
8. 113.04 ft² 9. 28.26 m²

2.1 Exercises

Concept Check

Fill-in-the-Blank. Complete each sentence using information found in this section.

1. A closed plane figure with three or more sides, where each side is a line segment is a/an _____.
2. The perimeter of a circle is called the _____.
3. When measuring area, use _____ units.
4. Volume is measured in _____ units.

True/False. Determine whether each statement is true or false. If a statement is false, explain how it can be changed so the statement will be true. (**Note:** There may be more than one acceptable change.)

5. Every square is a rectangle.
6. The length of the diameter of a circle is half of the length of the radius.
7. The height of a triangle is the distance between the base and the vertex opposite the base.
8. The $(b + c)$ in the trapezoid area formula represents the sum of the lengths of the base and the corners.
9. To find the volume of a can of corn, the formula $V = \pi r^2 h$ would be used.

Practice

Calculate the perimeter of each figure. Use $\pi \approx 3.14$.

1. A parallelogram with sides of length 15 cm and 7 cm.
2. A square with sides of length $4\frac{1}{2}$ km.
3. A trapezoid with sides of length 14.2 yd, 10.1 yd, 8 yd, and 15.8 yd.
4. A circle with diameter 60 cm.

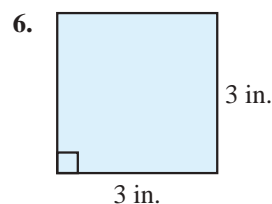
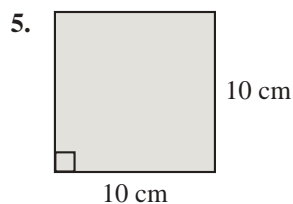

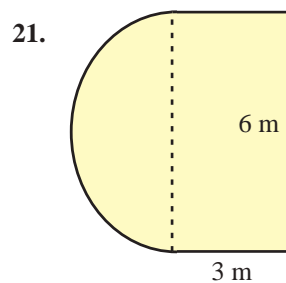
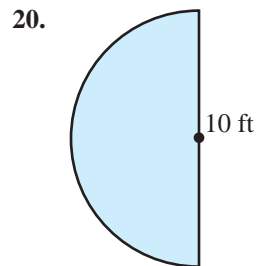
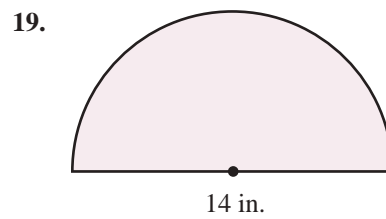
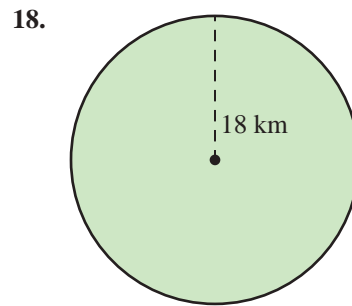
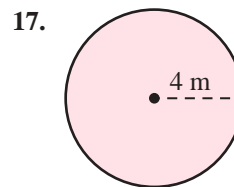
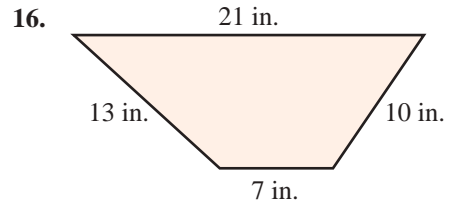
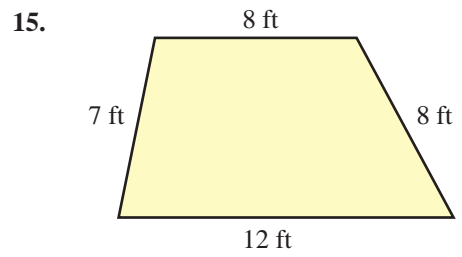
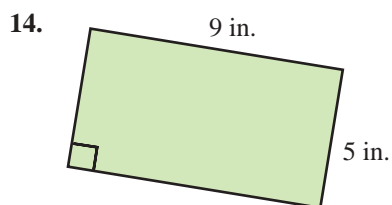
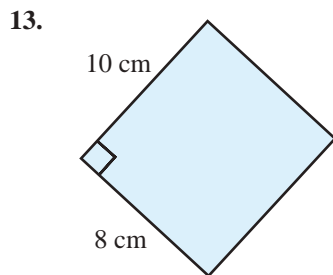
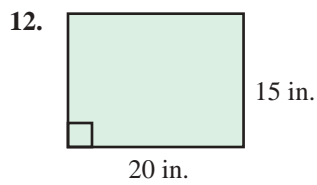
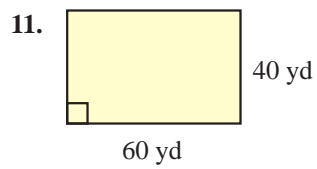
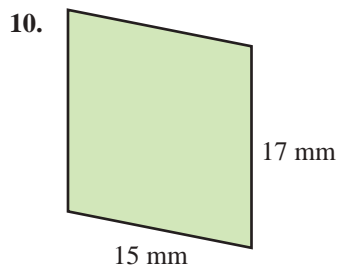
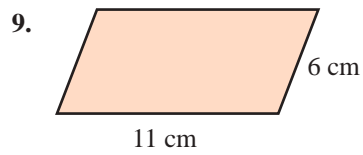
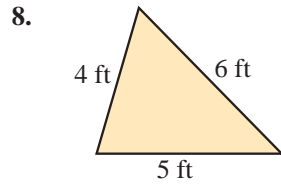
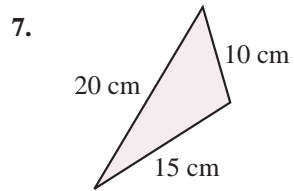

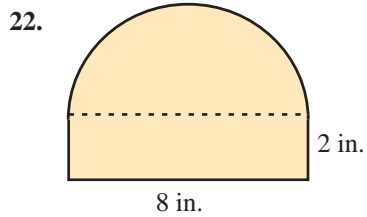

Calculate the area of each figure. Use $\pi \approx 3.14$.

23. A square with sides of length 9 ft.

24. A rectangle with length 21 km and width 25 km.

25. A triangle with height 16.4 cm and base 8.2 cm.

26. A trapezoid with height 30 mm and parallel sides of length 45 mm and 50 mm.

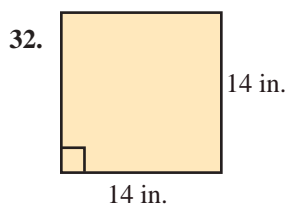
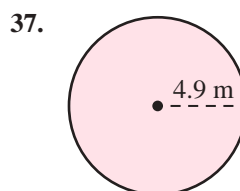
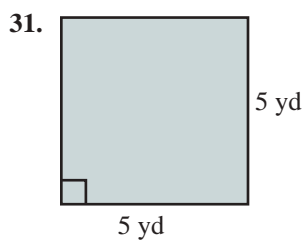
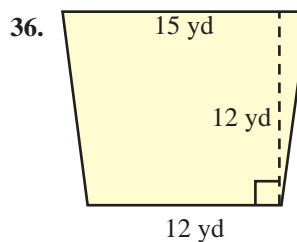
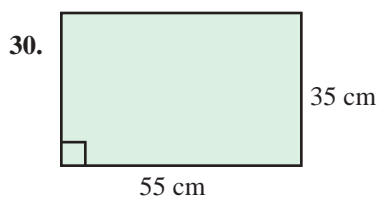
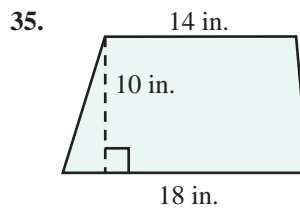
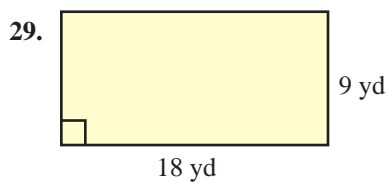
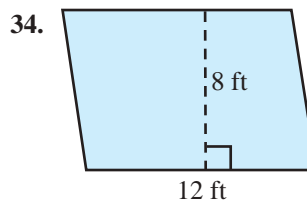
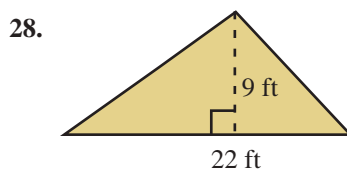
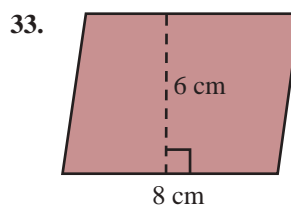
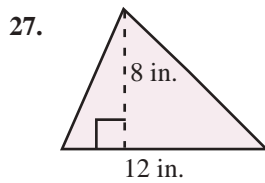

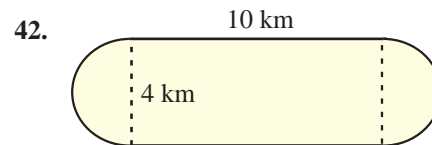
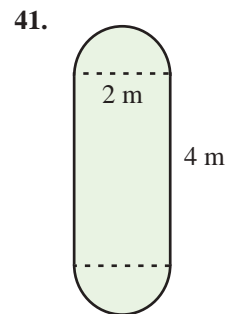
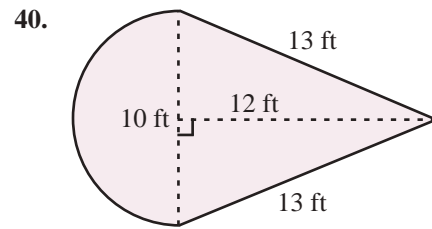
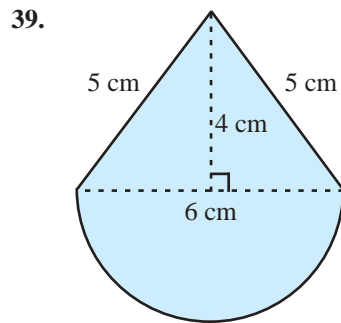
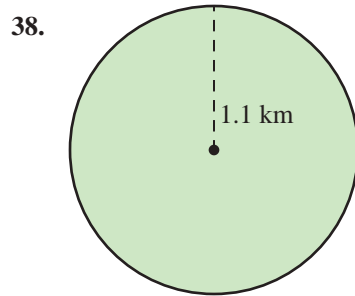

Calculate the volume of each solid. Use $\pi \approx 3.14$.

43. A rectangular solid with length 5 in., width 2 in., and height 7 in.
44. A right circular cylinder 15 in. high and 1 ft in diameter.
45. A sphere with radius 4.5 cm.
46. A sphere with diameter 12 ft.
47. A right circular cone 3 mm high with a 2 mm radius.
48. A rectangular pyramid with length 8 cm, width 1 cm, and height 30 cm.

Calculate the volume of each solid. See Examples 1 through 5. Use $\pi \approx 3.14$.

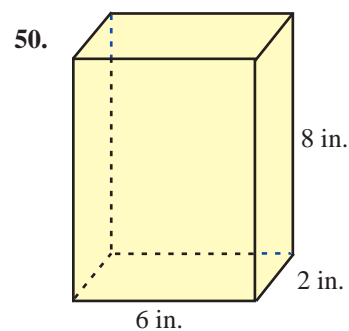
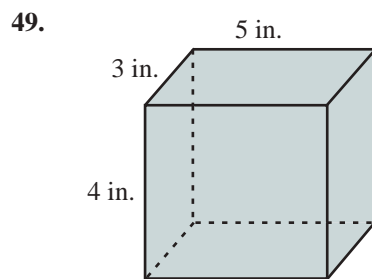

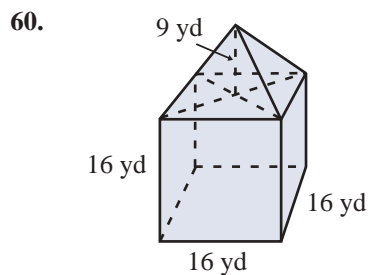
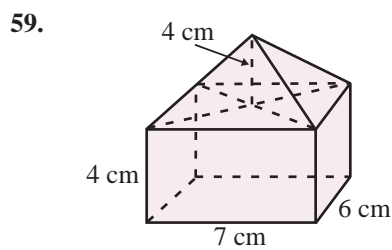
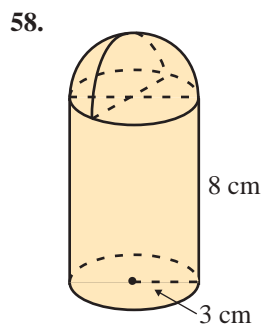
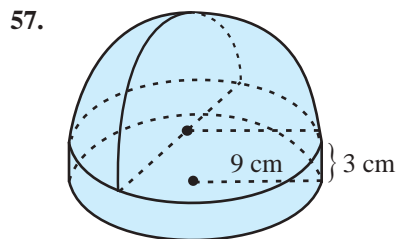
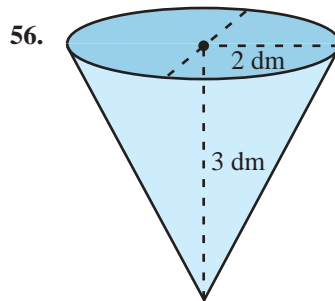
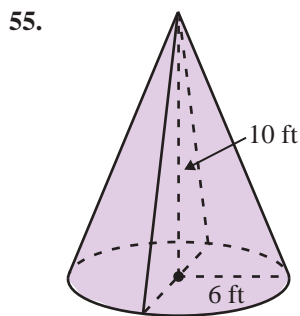
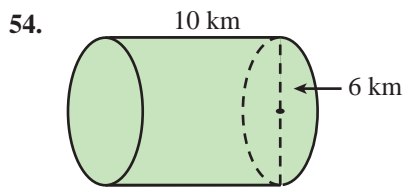
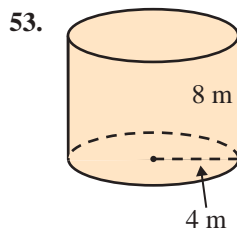
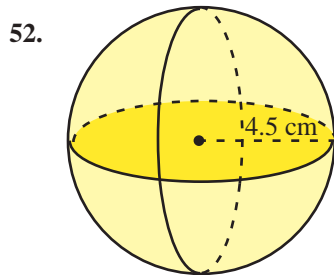
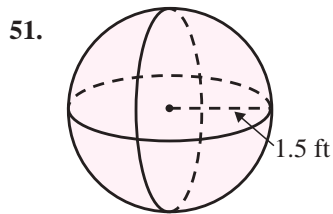

Applications

Solve. Use $\pi \approx 3.14$.

61. The Pentagon near Washington, D.C., is a five-sided building where each outside wall is 921 feet.¹
- What is the perimeter of the building?
 - If it takes a person 0.00341 minutes to walk 1 foot, how long will it take the person to walk completely around the building? Round your answer to the nearest tenth of a minute.

¹ Source: www.infoplease.com/spot/pentagon1.html ©HAWKES LEARNING

62. An engineer who is designing a new smartphone decides to add a soft neoprene edging to the phone. The phone itself is $4\frac{1}{2}$ inches tall and $2\frac{2}{5}$ inches wide. How much neoprene edging is needed to go along the outside edge of each smartphone?

63. The main stage at a theater is in the shape of a trapezoid. The owner of the theater is planning to install a new specially designed flooring system on the stage. The stage is 12 feet wide in the front and 15 feet wide in the back. The stage is 10 feet deep. How much flooring will the manager need?

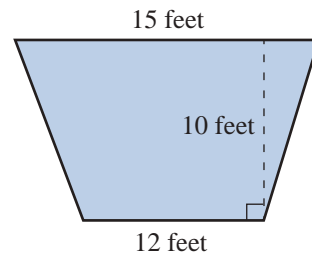

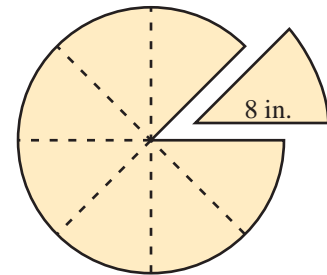

64. A large 16 in. pizza is cut into eight pieces.
- What is the perimeter of a single piece?
 - What is the area of this piece of pizza?



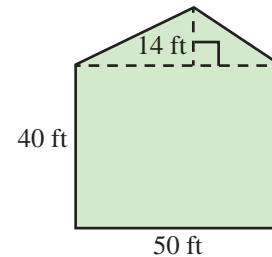

65. David is planting a five-sided lawn as shown in the figure below. The lawn consists of a 50 foot by 40 foot rectangle and an attached 14 foot high triangle.

- What is the area of the lawn to be planted?
- If one pound of grass seed will cover 200 square feet, how many pounds will be necessary to cover the entire lawn? (**Hint:** Divide the area by the number of square feet that one pound of seed will cover.)

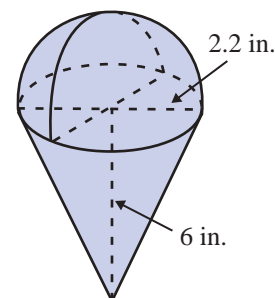

66.  A 6 in. tall ice cream cone is filled solid with ice cream where the final scoop of ice cream forms a perfect hemisphere above the top of the cone. What is the total volume of ice cream in the cone if the top of the cone has a 2.2 in. opening? Round your answer to the nearest hundredth.



67.  A cylindrical trash can has a hemispherical top (with a trap door for the trash). If the diameter of the can is 16 in. and its total height is 38 in., find its volume. (**Hint:** Begin by finding the height of the straight part of the can.)

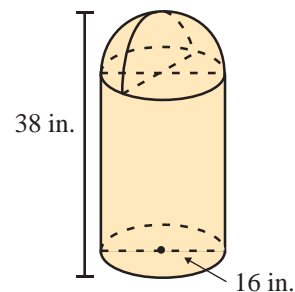

68. A rectangular tent with straight sides has a pyramidal shaped roof. The dimensions of the rectangular portion are 12 ft long, 10 ft wide, and 6 ft high. The peak of the pyramid is 2 ft above the top edge of the walls. What is the volume of the inside of the tent?

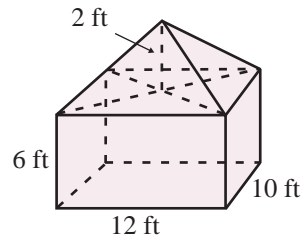

69. Disposable paper drinking cups, like those used at water coolers, are often cone-shaped. Find the volume of such a cup that is 9 cm high with a 3.2 cm radius. Express the answer to the nearest milliliter.

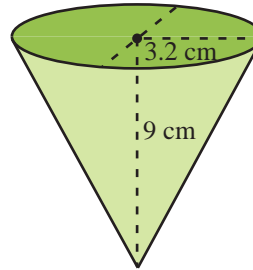

Writing & Thinking

70. Name as many polygons as you can and include the number of sides for each one.
71. Draw a rectangle and choose any point on one side of the rectangle. Draw line segments to the vertices on the opposite side (forming three triangles). Now cut out the two triangles on each end. Place these triangles inside the remaining triangle to show that the total of the two areas is equal to the area of the remaining triangle. Do this three different times choosing a different point each time. What fact does this illustrate about the area of a triangle?
72. List the steps and formulas you would use to find the volume of an ice cream cone (assuming the ice cream itself forms a perfect half sphere).

Determining Congruent Triangles (cont.)

3. Angle-Side-Angle (ASA)

If two triangles are such that two angles in one triangle are congruent to two angles in the other triangle and the lengths of the sides included between the angles are equal, then the two triangles are congruent.

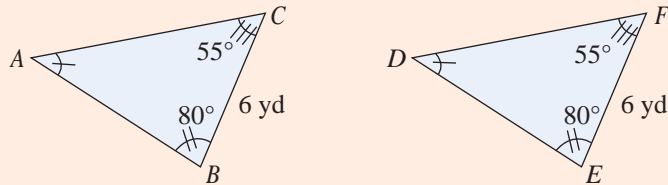

Triangle ABC is congruent to triangle DEF by ASA.

DEFINITION

Example 7 Determining Whether Triangles are Congruent

Determine whether triangles PQR and MNO are congruent.

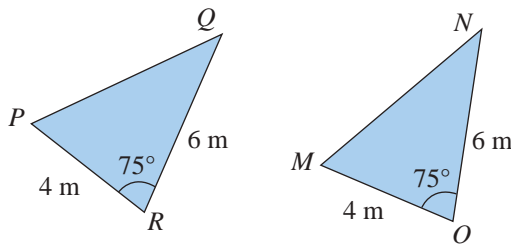

Solution

From the figure we see that $PR = MO = 4$, $QR = NO = 6$, and $m\angle R = m\angle O = 75$. As $\angle R$ and $\angle O$ are included between the pairs of equal-length sides, the two triangles are congruent by SAS (Side-Angle-Side).

Now work margin exercise 7.

Margin Exercise Answers

1. a. Right b. Obtuse c. Straight 2. a. $\angle DOC \cong \angle FOA$, $\angle AOB \cong \angle DOE$, and $\angle FOE \cong \angle BOC$ b. $\angle DOC = 40^\circ$ c. $m\angle FOE = 50^\circ$ d. Three angles adjacent to $\angle DOC$ are $\angle BOC$, $\angle DOE$, and $\angle DOF$. 3. Scalene 4. Yes 5. b 6. 2.5 cm 7. Yes, by ASA

7. Determine whether triangles JKL and MNO are congruent. If they are congruent, state the property that confirms that they are congruent.

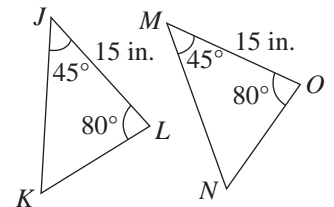

2.2 Exercises

Concept Check

Fill-in-the-Blank. Complete each sentence using information found in this section.

- Two rays with a common endpoint, called a vertex, form a/an _____.
- An angle with a measure less than 90° is a/an _____ angle.

3. A triangle with no equal sides is a/an _____ triangle.
4. When the measures of the three angles in a triangle are added, the sum is _____ degrees.
5. Similar triangles have the same _____ even though they may not have the same size.
6. In congruent triangles, the lengths of corresponding sides are _____.

True/False. Determine whether each statement is true or false. If a statement is false, explain how it can be changed so the statement will be true. (**Note:** There may be more than one acceptable change.)

7. The sum of the measures of two complementary angles is equal to the measure of one right angle.
8. Adjacent angles are two angles that share a vertex and a common side but do not overlap.
9. A triangle with three angles that each measure less than 90 degrees is an obtuse triangle.
10. Congruent triangles have corresponding angles that are equal.

Practice

Classify each angle as acute, right, obtuse, or straight.

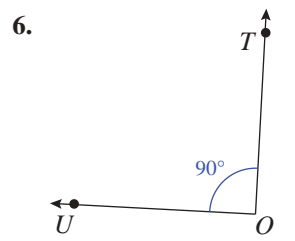
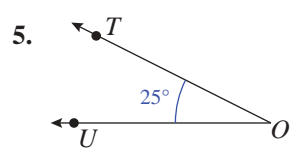
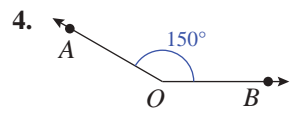
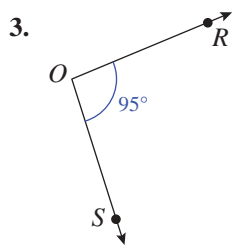
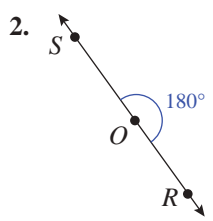
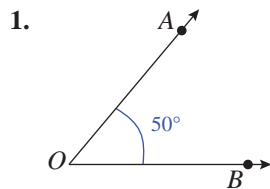

Use the definitions of acute, right, obtuse, and straight angles to answer each question.

7. In the figure shown, $\angle DOC$ is a straight angle and $m\angle BOA = 90^\circ$.

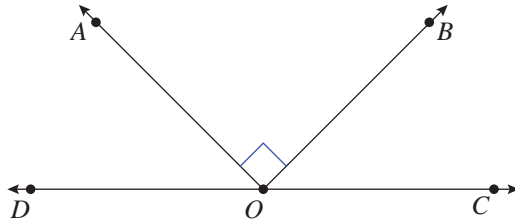

- What type of angle is $\angle AOC$?
 - What type of angle is $\angle BOC$?
 - What type of angle is $\angle BOA$?
8. Name the type of angle formed by the hands on a clock.

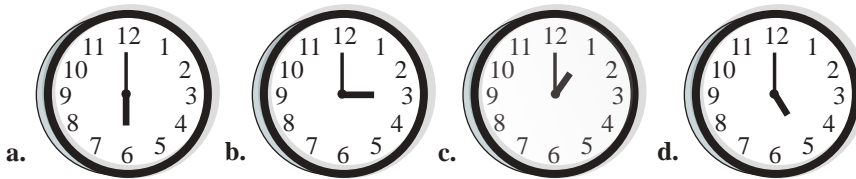

- at six o'clock
- at three o'clock
- at one o'clock
- at five o'clock

Use the definitions of complementary, supplementary, and straight angles to answer each question.

9. Assume that $\angle 1$ and $\angle 2$ are complementary.

- If $m\angle 1 = 15^\circ$, what is $m\angle 2$?
- If $m\angle 1 = 3^\circ$, what is $m\angle 2$?
- If $m\angle 1 = 45^\circ$, what is $m\angle 2$?
- If $m\angle 1 = 75^\circ$, what is $m\angle 2$?

10. Assume $\angle 3$ and $\angle 4$ are supplementary.

- If $m\angle 3 = 45^\circ$, what is $m\angle 4$?
- If $m\angle 3 = 90^\circ$, what is $m\angle 4$?
- If $m\angle 3 = 110^\circ$, what is $m\angle 4$?
- If $m\angle 3 = 135^\circ$, what is $m\angle 4$?

11. In the figure shown,

- Name all of the pairs of supplementary angles.
- Name all the pairs of complementary angles.

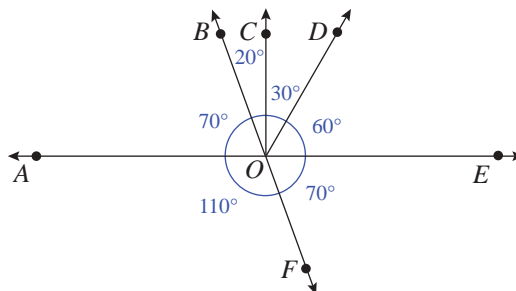

Use the definitions of adjacent and vertical angles to answer each question.

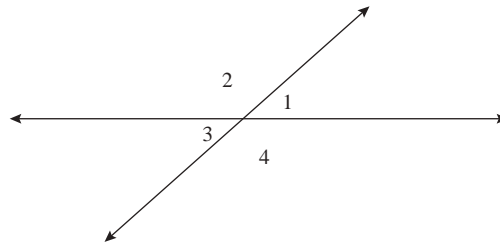

12. The figure shows two intersecting lines.
- If $m\angle 1 = 30^\circ$, what is $m\angle 2$?
 - Is $m\angle 3 = 30^\circ$? Give a reason for your answer other than the fact that $\angle 1$ and $\angle 3$ are vertical angles.
 - Name two pairs of congruent angles.
 - Name four pairs of adjacent angles.
13. The figure shows two intersecting lines where $m\angle 1 = 30^\circ$. Find the measures of the other three angles.

14. Given that $m\angle 1 = 42^\circ$ in the figure, find the measures of the other three angles.

15. In the figure shown, l , m , and n are straight lines with $m\angle 1 = 20^\circ$ and $m\angle 6 = 90^\circ$.
- Find the measures of the other four angles.
 - Which angle is supplementary to $\angle 6$?
 - Which angles are complementary to $\angle 1$?

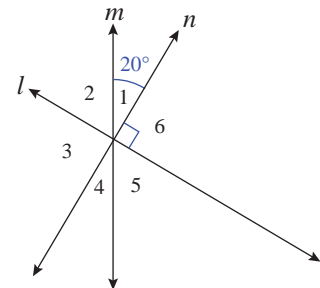

16. In the figure, $m\angle 2 = m\angle 3 = 40^\circ$. Find all other pairs of angles that are congruent.

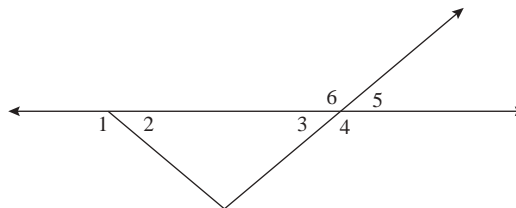

Classify each triangle in the most precise way possible, given the indicated lengths of its sides and/or measures of its angles.

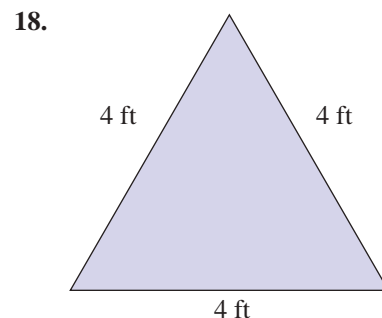
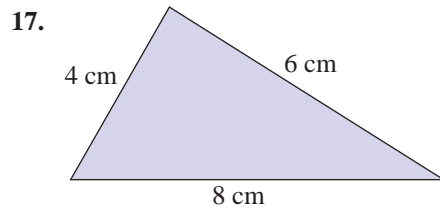

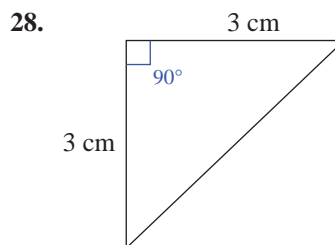
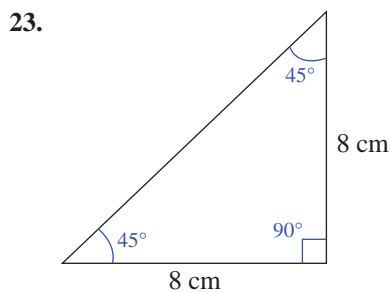
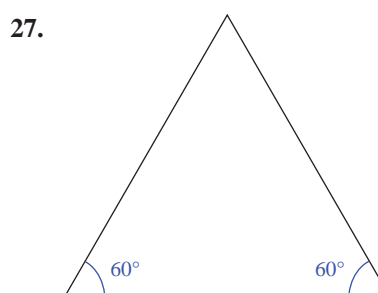
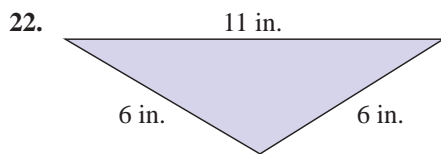
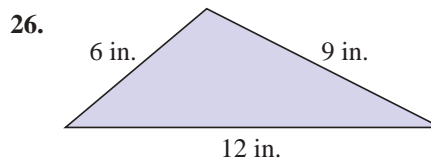
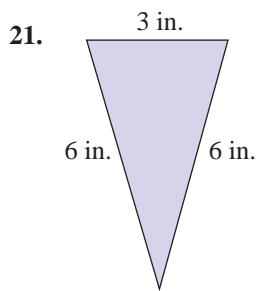
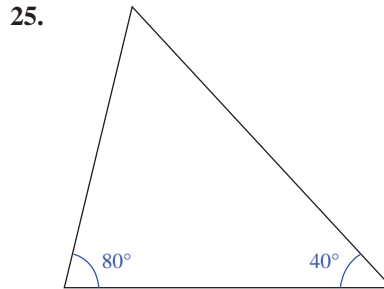
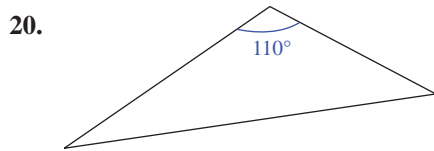
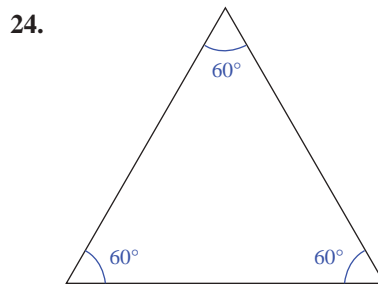
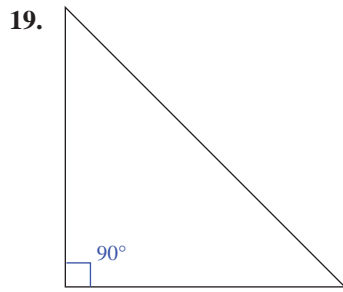

Determine whether each pair of triangles is similar. If the pair of triangles is similar, explain why and indicate the similarity by using the \sim symbol.

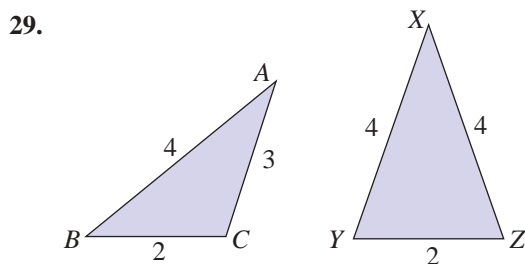

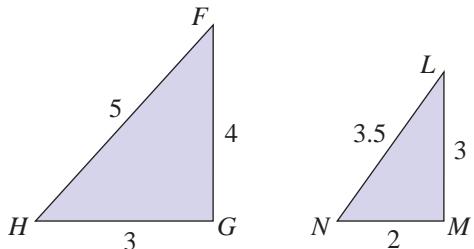
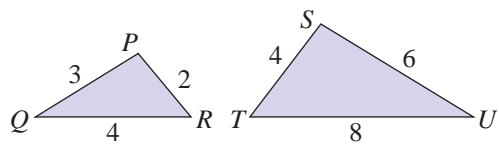
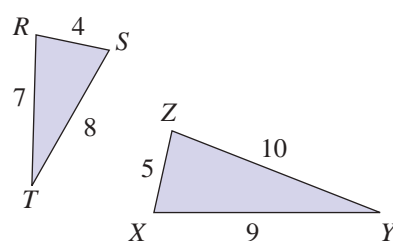
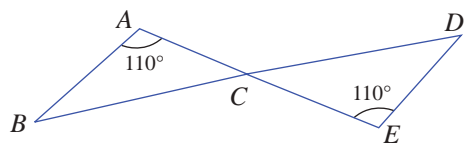
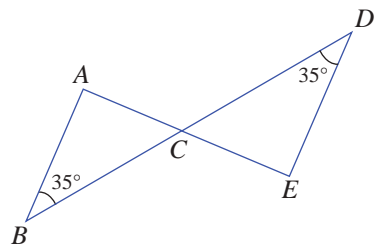
30. 
31. 
32. 
33. 
34. 

Find the values for x and y .

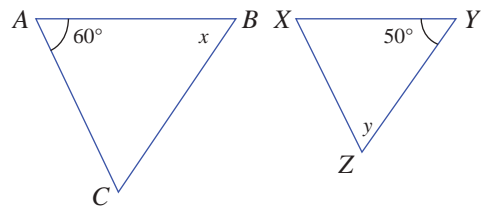
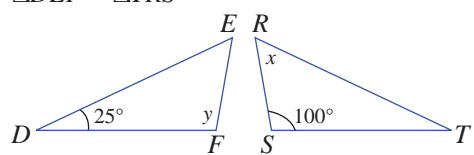
35. $\triangle ABC \sim \triangle XYZ$

36. $\triangle DEF \sim \triangle TRS$

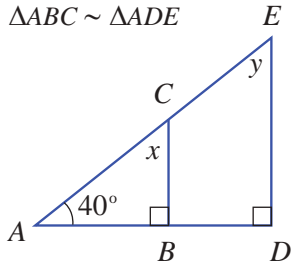
37. $\triangle ABC \sim \triangle ADE$

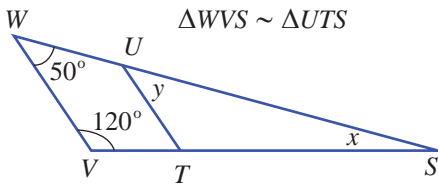

38. $\triangle WVS \sim \triangle UTS$



39. $\triangle RST \sim \triangle UVW$

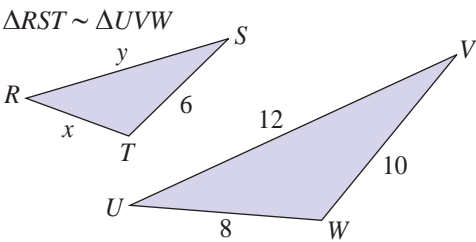

40. $\triangle LMN \sim \triangle OPQ$

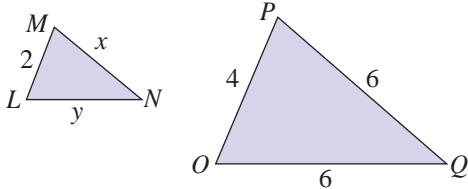

41. $\triangle ABC \sim \triangle EDC$

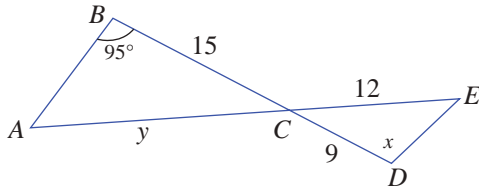

42. $\triangle ABC \sim \triangle EDC$

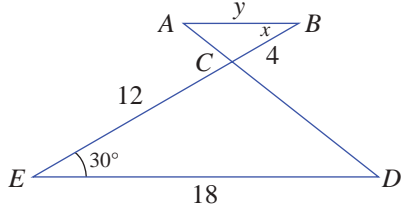

Determine whether each pair of triangles is congruent. If the pair of triangles is congruent, state the property that confirms that they are congruent.

43.

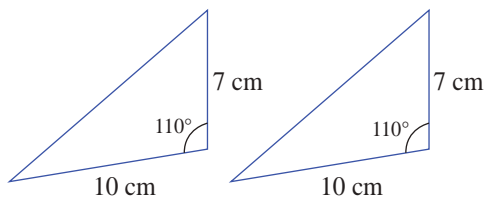

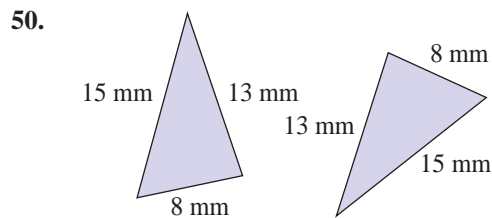
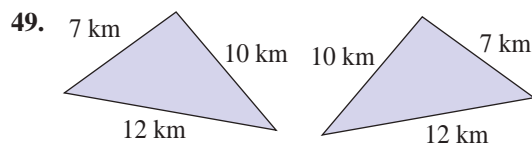
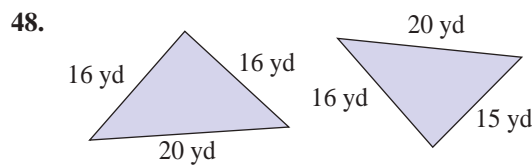
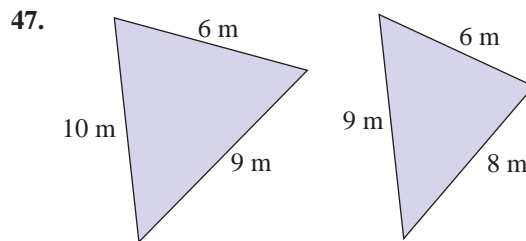
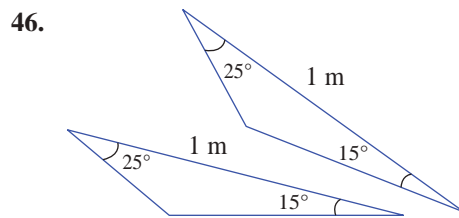
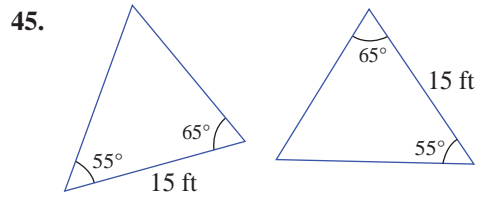
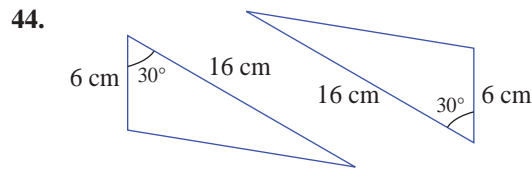

Applications

Solve.

51. A child's playhouse is built to look like a smaller version of the family house, where the ends of the roofs have similar proportions. The width of the main house (AB) is 32 feet and the length from the peak to the gutter of the roof for one of the sides is 20 feet. If the width of the playhouse (DF) is 12 feet, what is the length from the peak to the gutter (DE) of the playhouse roof?

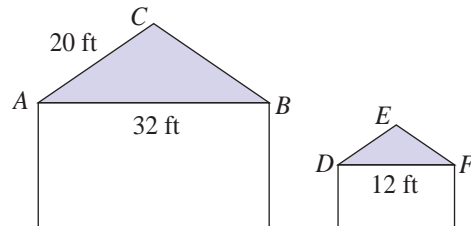

52. A camera uses a lens that will look at a properly focused object (such as a person or a tree) and then display an inverted image of this object on a screen or film that is on the opposite side of the lens as shown in the figure. If a picture of a 50-foot tall building (AB), which is 150 feet from the lens (AC) is photographed, how tall is the image (DE) if the film on the opposite side (CD) is 0.3 inch from the lens.

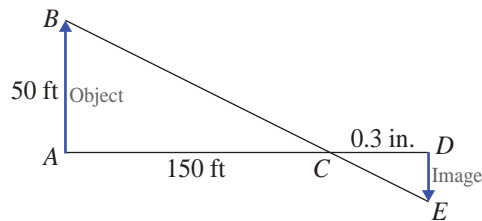

53. A surveyor is trying to figure out the length of a large quarry. The surveyor sees two trees at the edge of the quarry that are close together, and notices that the line between the two trees is parallel to the line that connects the edges of the quarry at its widest. We will call the two trees points R and S and the points X and Y will be the endpoints of the line connecting the two edges of the quarry. Drawing an imaginary line from R to Y and from S to X creates two similar triangles, $\triangle RST$ and $\triangle YXT$, with a common point T . If the length of RS is 25 yd, the length of ST is 16 yd, and the length of XT is 80 yd, what is the length of the quarry (the distance between X and Y)? (See the figure.)

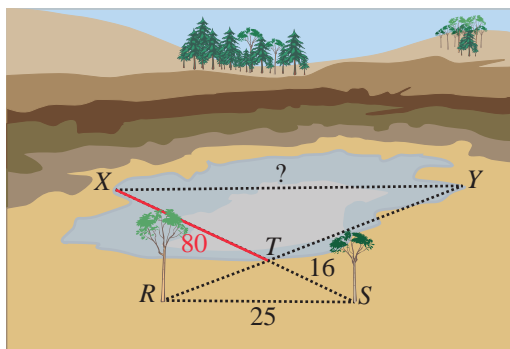

54. You and a friend are walking to class and want to figure out the height of the tree next to your building. Your friend is exactly 6 ft tall and casts 4 ft shadow. The tree casts a 12 ft shadow. How tall is the tree?

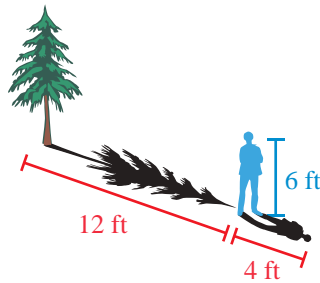

History

Thales was a Greek mathematician who lived approximately 624 BC to 540 BC. While he was an engineer by trade, he was considered by Aristotle to be the first philosopher in the Greek tradition. Thales has also been referred to as the Father of Science. While it is difficult to give Thales credit for measuring the Great Pyramid as described in Exercise 55 (due to a lack of written records), there are stories of him doing this as well as using this method to measure the distances of ships at sea.

55. Thales was a mathematician circa 500 B.C. who wanted to know the height of the Great Pyramid. He discovered he could calculate the height of the pyramid using similar triangles. He stuck a rod in the ground that rose 5 ft into the air and cast an 8 ft shadow. If, at the same time, the length of the shadow from the Great Pyramid was 768 ft, determine the height of the Great Pyramid.

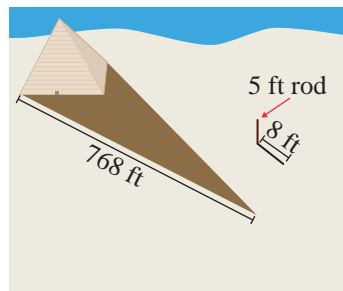

56. At what height off the table would you need to hit a ping pong ball for it to skim the net (0.5 feet tall) and hit on the edge of the opposite side of the table 9 feet away from you? Assume that the net is in the exact center of the table (with 4.5 feet on either side) and that your paddle is directly above the edge of the table.

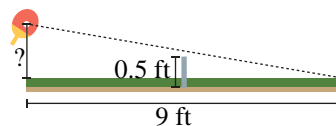

57. Your neighbors are hanging their holiday lights. The ladder they are currently using is 12 feet long and when leaned up against the house just reaches the top of their 8-foot tall porch. How long of a ladder will they need to reach the top of their chimney which is at a height of 32 feet? (Assume that both ladders are placed such that they make the same angle with the ground.)

58. The sloping surface of a hill (from base to peak) is 500 meters long. Paul starts at the base of the hill and walks uphill 25 meters which results in a gain of 8 meters in elevation. What is the height of the hill? (**Hint:** As shown on the accompanying drawing, there are two similar triangles $\triangle ABC$ and $\triangle ADE$. Solve for DE .)

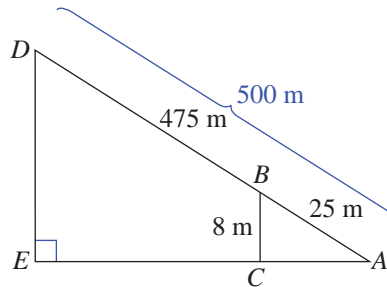

59. A sloop is a sailboat that has two triangular sails on a single mast. If the smaller sail is 12 feet along the mast (CB), and 5 feet along its bottom (AC), and the larger sail is 16.5 feet along the mast (ZY), how wide is the larger sail at the bottom (XZ) if $\triangle ABC$ and $\triangle XYZ$ are similar triangles? Round your answer to the nearest tenth.

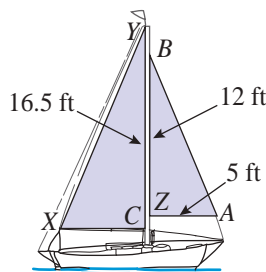

Writing & Thinking

60. a. The supplement of a right angle is what type of angle?
 b. The supplement of an obtuse angle is what type of angle?
 c. The supplement of an acute angle is what type of angle?
61. Determine the errors in the following statement. Assume $\triangle ABC \sim \triangle DEF$.
- Corresponding angles are congruent. This means $m\angle A = m\angle D$, $m\angle B = m\angle F$, and $m\angle C = m\angle E$.
 - Corresponding sides are the same length.
62. Kelly needs to determine whether two triangles are similar. She was given the following information.

For $\triangle ABC$ and $\triangle DEF$, $AB = 3.6$, $AC = 2.4$, $BC = 2$ and $DE = 9$, $DF = 6$, $EF = 5$.

What should be her first step?

Next, calculate the sum of the products.

$$0.095 + 0.255 + 0.522 = 0.872$$

Now calculate the sum of the weights.

$$0.10 + 0.30 + 0.60 = 1$$

Finally, divide the sum of the products by the sum of the weights. Since the sum is 1, the quotient is the same as the sum of the products: 0.872.

Thus, the weighted mean is 0.872 or 87.2%.

Note that the weighted mean is different than the arithmetic mean.

Now work margin exercise 9.

Margin Exercise Answers

1. 50.875 2. 82.25 3. 4 4. 3 5. 4 6. multimodal: 32 and 45 7. There is no mode. 8. mean: 4.5; median: 5; mode: 5 9. 83%

2.3 Exercises

Concept Check

Fill-in-the-blank. Complete each sentence using information found in this section.

1. A measure of _____ describes what a typical value in a data set looks like.
2. The _____ is the sum of all data values divided by the number of data values.
3. The middle value in a ranked data set is called the _____.
4. A data set that has two modes is said to be _____.
5. A data set is multimodal if there are more than _____ data values that qualify as the mode.
6. A _____ is one in which some data values contribute more to the mean than others.

True/False. Determine whether each statement is true or false. If a statement is false, explain how it can be changed so the statement will be true. (**Note:** There may be more than one acceptable change.)

7. The median is the data value that occurs most often in a data set.
8. The mean is also called the arithmetic average.
9. The mean must be a value in the data set.
10. There can be more than one median.

Practice

Find the mean, median, and mode for each of the following data sets.

- 15, 16, 12, 18, 23, 21, 20, 19, 14, 28
- 43, 49, 49, 41, 43, 45, 46, 48, 46, 42, 44, 45, 47, 49
- \$6, \$8, \$4, \$9, \$6, \$5, \$7, \$6, \$5, \$9, \$12
- 3, 3, 3, 3, 3, 3, 3, 3, 3, 3
- 82, 84, 86, 84, 86, 84, 86, 82
- 110, 120, 115, 112, 114, 120, 115, 110, 112, 114

Solve.

7. Consider the following statistics regarding yearly salaries at Steppingstone Incorporated.

Mean: \$110,000 Median: \$78,000 Mode: \$62,000

- What is the most common salary?
 - What salary did half the employees exceed?
8. Consider the following statistics regarding midterm exam scores.

Mean: 77 Median: 81 Mode: 83

- What is the most common score?
- What score did half the students score below?

Find the mean, median, and mode for each of the following scenarios.

9. A random sample of the weights of passengers' carry-on luggage was collected. The weights (in pounds) of the luggage pieces were as follows.

36 44 40 31 33 40 37 40 38 41

10. A random sample of the heights of basketball players at a local tournament was collected. The heights (in inches) of the players were as follows.

62 78 72 71 74 69 73 74 75 77

11. The numbers of pacifiers lost each day by babies at the local daycare are as follows.

3 2 0 2 0 2 0 3 4 2 1 2

12. Bowling scores by bowlers in a local recreational league are as follows.

164 185 152 160 163 165 195 185 182 167

13. Golf scores by golfers in a local recreational league are as follows.

82 78 84 98 72 91 77 78 86 90

14. The numbers of dogs at a local park each evening are as follows.

28 15 22 10 12 20 22 17 11 17 24

For each frequency distribution, determine the mean, median, and mode of the data set. See Example 8.

15.

| Text Messages Sent in a Day | Number Reporting Texts Sent (Frequency) |
|-----------------------------|---|
| 5 | 8 |
| 6 | 10 |
| 7 | 8 |
| 8 | 6 |
| 9 | 4 |
| 10 | 4 |

16.

| Number of Siblings in a Family | Frequency |
|--------------------------------|-----------|
| 0 | 2 |
| 1 | 10 |
| 2 | 12 |
| 3 | 5 |
| 4 | 2 |
| 5 | 1 |

17.

| Number of Pets in a Household | Frequency |
|-------------------------------|-----------|
| 0 | 4 |
| 1 | 8 |
| 2 | 12 |
| 3 | 6 |
| 4 | 5 |
| 5 | 5 |

18.

| Number of Work Emails Per Day | Frequency |
|-------------------------------|-----------|
| 25 | 3 |
| 26 | 5 |
| 27 | 6 |
| 28 | 1 |
| 29 | 2 |
| 30 | 8 |

Find the mode for each of the following scenarios. State if the data set is unimodal, bimodal, multimodal, or has no mode. See Examples 5 through 7.

19. The number of bottles used each day by babies at a local daycare are as follows.

6 4 5 6 5 8 7 10 6 5 9 10

20. A sample of batting averages by players in a local softball recreational league are as follows.

.250 .285 .267 .290 .310 .260

.335 .301 .315 .325 .279 .283

21. The number of free throws taken by team members during a recent basketball game are as follows.

3 2 0 4 6 5 2 8 2 7 1 3 1 4 3

22. The number of pieces of junk mail received each day are as follows.

4 1 3 2 4 2 5 1 2 3 5 1 3 5 4

23. The number of movies seen in a cinema each month are as follows.

8 1 4 3 5 2 3 5 4 7 3

24. The number of pencils lost by teachers during a week are as follows.

1 0 4 3 5 0 2 4 6 2 4 3 2 1 3 5 7

Applications

Solve.

25. Suppose you have earned scores 78, 84, 68, and 88 on exams in one of your classes.
- What is the mean of the scores?
 - What score would you need on the next exam to have an overall mean of 80?
 - If the maximum score on an exam is 100, is it possible to have a mean of 85 after the fifth exam? Explain.
26. Suppose you have earned scores 64, 80, 71, and 86 on exams in one of your classes.
- What is the mean of the scores?
 - What score would you need on the next exam to have an overall mean of 75?
 - If the maximum score on an exam is 100, is it possible to have a mean of 80 after the fifth exam? Explain.
27. A teacher computes a student's average using a weighted mean where quizzes count 25%, homework 15%, and exams 60%. If a student's quiz grade is 82%, homework 90%, and exams 88%, what is the student's average?
28. A teacher computes a student's average using a weighted mean where quizzes count 15%, homework 10%, and exams 75%. If a student's quiz grade is 90%, homework 92%, and exams 85%, what is the student's average?
29. A savvy consumer looking to buy a new camera decided to give weights to the areas she thought were important in the shopping process. She decides to give image quality 50%, build quality 20%, and performance 30%. She has narrowed her decision down to two choices. Camera A scores 8 for image quality, 6 for build quality, and 9 for performance. Camera B scores 7 for image quality, 9 for build quality, and 8 for performance. What is the weighted mean for each camera, and based on the scores, what camera should she purchase?
30. In a local golf tournament, the first and second round score counts for 25% of the average score, and the third round counts for 50%. Lydia scores 76 in the first round, 73 in the second round, and 75 in the third round while Adah scores 78 in the first round, 76 in the second round, and 68 in the third round. What is the weighted mean for Lydia and Adah, and based on the scores, who wins the tournament? (In golf, the lower score wins.)

31. At a certain college, the overall grade point average is calculated using a weighted mean. Points are assigned as follows per credit hour: A is worth 4 points, B is worth 3 points, C is worth 2 points, D is worth 1 point, and F is worth 0 points. Suppose at the end of the semester, you earned a B in your 4-credit-hour humanities course, an A in your 3-credit-hour biology course, an A in your 4-credit-hour mathematics course, and a C in your 3-credit-hour writing course. What is your grade point average for the semester? Round your answer to the nearest tenth.
32. At a certain college, the overall grade point average is calculated using a weighted mean. Points are assigned as follows per credit hour: A is worth 4 points, B is worth 3 points, C is worth 2 points, D is worth 1 point, and F is worth 0 points. Suppose at the end of the semester, you earned a C in your 4-credit-hour business course, an A in your 3-credit-hour chemistry course, an B in your 4-credit-hour mathematics course, and a B in your 3-credit-hour writing course. What is your grade point average for the semester? Round your answer to the nearest tenth.

Writing & Thinking

33. Eliana is trying to average 6 made field goals per basketball game for the month. Thus far, she has had made field goals of 8, 4, 9, 5, 7, 6, 8, and 2 over the first eight 8 games. She has two games left. What must she average over the remaining two games to end up with a mean of 6 made field goals per basketball game for the month?
34. Give an example of when it would be better to use the mode than median.

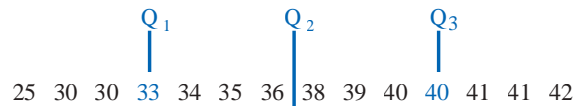

First Quartile = 33

Second Quartile (Median) = 37

Third Quartile = 40

Now work margin exercise 5.

Margin Exercise Answers

1. 9 2. 26 3. Approximately 7.76 points 4. Alejandro's score is not good enough to get into his top college choice. 5. First Quartile = 69; Second Quartile (Median) = 71; Third Quartile = 74

2.4 Exercises

Concept Check

Fill-in-the-blank. Complete each sentence using information found in this section.

- The _____ is the difference between the largest value and smallest value in a data set.
- A _____ describes the "spread" of a data set.
- The _____ indicates how much we would expect a data value to differ from the mean.
- _____ divide the data set up into 100 equal parts and indicates approximately what percentage of the data lies at or below the data value
- A measure of _____ describes the position of a specific data value in a data set compared to the rest of the values in the set.
- When percentiles divide a data set into four equal parts the parts are called _____.

True/False. Determine whether each statement is true or false. If a statement is false, explain how it can be changed so the statement will be true. (**Note:** There may be more than one acceptable change.)

- The standard deviation takes only two data values into consideration.
- The median is the second quartile.
- Quartiles divide a data set into eight equal parts.
- The larger the standard deviation the more the data values are spread out

Practice

Find the range and standard deviation for each of the following data sets. Round the standard deviation to the nearest hundredth. See Examples 1 through 3.

- 14, 18, 16, 15, 18, 19, 12, 14, 16, 19
- 42, 45, 44, 43, 46, 48, 47, 48, 49, 42, 43, 44, 46, 48
- \$20, \$22, \$24, \$29, \$26, \$25, \$23, \$26, \$25, \$29, \$32, \$28
- 7, 7, 7, 7, 7, 7, 7, 7, 7, 7, 7, 7
- 21, 23, 22, 23, 26, 24, 20, 25
- 6, 8, 9, 8, 5, 7, 10, 5, 8, 7
- A random sample of the weights of passengers' carry-on luggage was collected. The weights (in pounds) of the luggage pieces were as follows.

36 44 40 31 33 40 37 40 38 41

- A random sample of the heights of basketball players at a local tournament was collected. The heights (in inches) of the players were as follows.

62 78 72 71 74 69 73 74 75 77

- The number of pacifiers lost each day by babies at the local daycare is as follows.

3 2 0 2 0 2 0 3 4 2 1 2

- A sample of bowling scores by bowlers in a local recreational league are as follows.

164 185 152 160 163 165 195 185 182 167

- Golf scores by golfers in a local recreational league are as follows.

82 78 84 98 72 91 77 78 86 90

- The number of rebounds gathered by players in a recent basketball game are as follows.

4 8 6 7 5 4 8 9 12 6

- Use the following statistics regarding yearly salaries at a local corporation.

Q_1 : \$64,000 Q_2 : \$78,000 Q_3 : \$82,000 80th Percentile: \$84,500

- What salary did half the employees exceed?
- About what percentage of employees' salaries exceeded \$82,000?
- About what percentage of the employees earned \$64,000 or less?
- About what percentage of the employees earned more than \$84,500?

- 14.** Use the following statistics regarding monthly salaries at a local insurance company.

First Quartile: \$38,000 Second Quartile: \$51,000

Third Quartile: \$76,000 84th Percentile: \$87,500

- What salary did half the employees exceed?
 - About what percent of the employees' salaries exceeded \$38,000?
 - About what percent of the employees' salaries was less than \$76,000?
 - About what percent of the employees' salaries was more than \$87,500?
- 15.** Use the following statistics regarding the hourly wage for staff at a local company.

First Quartile: \$8.00/hour Second Quartile: \$16.00/hour

Third Quartile: \$22.00/hour 68th Percentile: \$19.00/hour

- What hourly wage did half the employees exceed?
- About what percent of the employees' hourly wage exceeded \$19.00/hour?
- About what percent of the employees' hourly wage was less than \$16.00/hour?
- About what percent of the employees' hourly wage was less than \$22.00/hour?

Find the quartiles for each of the following scenarios. See Example 5

- 16.** A sample of golf scores by golfers in a local tournament are as follows.

82 78 68 69 74 71 73 72 80 81

- 17.** A sample of assists by point guards in a local basketball tournament are as follows.

8 2 3 4 6 2 5 8 12 5 4 7 9

- 18.** A sample of the number of text messages sent each day by teenagers is as follows.

12 15 11 10 6 20 25 18 22 16 15 20 21 23

- 19.** The number of emails sent per day are as follows.

34 36 22 38 40 28 20 21 32 30 12 41

- 20.** The number of text messages sent per day are as follows.

8 15 4 20 45 3 10 22 30 10 15 25

- 21.** The number of diapers changed per day are as follows.

12 15 8 6 12 10 14 13 8 10 15 14 9

Applications

Solve.

22. Brenda is applying to medical schools that only accept applicants who score in the top 10% on the MCAT. Brenda receives her MCAT score that indicates that she scored at the 80th percentile. Will Brenda meet the criteria for the medical schools she is applying to?
23. On a recent standardized test, Carlos scored at the 80th percentile, Alessandro scored at the third quartile, and Isabella scored at the 82nd percentile. Which of the three had the best test score?
24. Two English classes took the same exam. Both classes had a mean score of 85, but one class had a standard deviation of 3 while the other had a standard deviation of 5. What conclusion can be drawn about the exam scores of the two classes?
25. A statistics class recently took an exam that resulted in a mean of 82. If the standard deviation for the exam scores is 3.5, what does that indicate?

Writing & Thinking

26. Given the following data set, what would be a better measure of dispersion, the range or standard deviation? Why?

45 48 46 45 21 47 44 43 48 49 59 43

27. Give an example of two data sets where the range is the same but the standard deviation is different.
28. Explain, in your own words, what standard deviation indicates about a data set.

Solution

There are no values of x for which $|x| = -3$. The absolute value can never be negative. There is **no solution**.

Now work margin exercise 10.**Example 11 Application: Solving Absolute Value Equations**

During the manufacturing of machine parts, certain measurements of the part must stay within a tolerance range or the part will be defective. The quality control manager determines that the maximum amount the length of a screw can vary from its targeted length of 12 millimeters and not be defective is 2 millimeters. If x represents the maximum acceptable difference in length from the target, either positive or negative, then $|x| = 2$. What are the maximum amounts that the screw length can vary from its target?

Solution

To find the maximum the screw length can vary from its target, solve the equation $|x| = 2$ millimeters. This gives the following two values for x : $x = -2$ millimeters and $x = 2$ millimeters.

Thus, the maximum amounts that the screw length can vary are -2 millimeters and 2 millimeters.

Now work margin exercise 11.

11. A quality control manager determines that the maximum amount the width of a latch can vary from its targeted length and not be defective is 3 millimeters. If y represents the maximum acceptable error, either positive or negative, then what are the maximum amounts that the hatch width can vary from its target?

Margin Exercise Answers

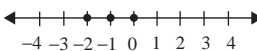
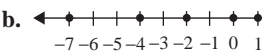
1. a. -10 b. $+8$ 2. a.  b.  3. a. $1, 20$

b. $-6, 1, 20$ c. $-6, -\frac{1}{7}, 1, 20$ d. All numbers in S are real numbers.

4.  5.  6. a. True b. False c. True d. True

e. False 7. a. 4 b. 3.3 c. -7.4 8. True 9. $z = 3, -3$ 10. No solution 11. -3 millimeters and 3 millimeters

3.1 Exercises

Concept Check

Fill-in-the-Blank. Complete each sentence using information found in this section.

- The set of numbers that includes the whole numbers and their opposites is the set of _____.
- A number that can be written as a fraction is a/an _____ number.
- Infinite nonrepeating decimal numbers are _____ numbers.
- A number's distance from 0 on a number line is the number's _____.

5. The _____ of a number is the point that corresponds to the number on a number line.
6. The symbols $<$ and $>$ are known as _____ symbols.

True/False. Determine whether each statement is true or false. If a statement is false, explain how it can be changed so the statement will be true. (**Note:** There may be more than one acceptable change.)

7. On a number line, smaller numbers are always to the left of larger numbers.
8. The absolute value of a negative number is a positive number.
9. All whole numbers are also integers.
10. Zero is a positive number.

Practice

Find the opposite of each integer. See Example 1.

- | | |
|---------|---------|
| 1. -3 | 4. -0 |
| 2. -7 | 5. $+2$ |
| 3. 0 | 6. $+6$ |

Graph each set of real numbers on a real number line. See Examples 2, 4, and 5.

- | | |
|------------------------------------|--|
| 7. $\{1, 2, 5, 6\}$ | 14. $\{-3.4, -2, -0.5, 1, \frac{5}{2}\}$ |
| 8. $\{-3, -2, 0, 1\}$ | 15. $\{-\frac{7}{2}, -1.5, 1, \frac{4}{3}, 2\}$ |
| 9. $\{2, -3, 0, -1\}$ | 16. $\{-4, -\frac{7}{3}, -1, 0.2, \frac{5}{2}\}$ |
| 10. $\{-2, -1, 4, -3\}$ | 17. all whole numbers less than 4 |
| 11. $\{0, -1, \frac{7}{4}, 3, 1\}$ | 18. all negative integers greater than -4 |
| 12. $\{-2, -1, -\frac{1}{3}, 2\}$ | 19. all whole numbers less than 0 |
| 13. $\{-\frac{3}{4}, 0, 2, 3.6\}$ | 20. all natural numbers less than or equal to -1 |

List the numbers in the set $A = \{-7, -\sqrt{6}, -2, -\frac{5}{3}, -1.4, 0, \frac{3}{5}, \sqrt{5}, \sqrt{11}, 4, 5.9, 8\}$ that are described in each exercise. See Example 3.

- | | |
|---------------------|------------------------|
| 21. Natural numbers | 24. Irrational numbers |
| 22. Whole numbers | 25. Rational numbers |
| 23. Integers | 26. Real numbers |

Fill in each blank with the appropriate symbol that will make the statement true: $<$, $>$, or $=$. See Examples 6 through 8.

27. $4 \underline{\hspace{1cm}} 6$

28. $-3 \underline{\hspace{1cm}} 1$

29. $-2 \underline{\hspace{1cm}} -4$

30. $-8 \underline{\hspace{1cm}} 0$

31. $-20 \underline{\hspace{1cm}} -19$

32. $-67 \underline{\hspace{1cm}} -50$

33. $-(-4.3) \underline{\hspace{1cm}} 4.3$

34. $5.6 \underline{\hspace{1cm}} -(-8.7)$

35. $-\frac{3}{4} \underline{\hspace{1cm}} -1$

36. $-2.3 \underline{\hspace{1cm}} -2\frac{3}{10}$

37. $\frac{1}{3} \underline{\hspace{1cm}} \frac{1}{2}$

38. $-\frac{1}{2} \underline{\hspace{1cm}} -\frac{1}{3}$

39. $|-4| \underline{\hspace{1cm}} 4$

40. $|7| \underline{\hspace{1cm}} -7$

41. $|-8| \underline{\hspace{1cm}} -8$

42. $-15 \underline{\hspace{1cm}} |-15|$

Determine whether each statement is true or false. If a statement is false, rewrite it in a form that is a true statement. (There may be more than one way to correct a statement.) See Examples 6 and 8.

43. $0 = -0$

44. $-22 < -16$

45. $-9 > -8.5$

46. $-17 \leq 17$

47. $4.7 \geq 3.5$

48. $|-5| = 5$

49. $-|-7| \geq -|7|$

50. $|-8| \geq 4$

51. $-|-3| < -|4|$

52. $\left|-\frac{5}{2}\right| < 2$

List the possible values for x for each statement. See Examples 9 and 10.

53. $|x| = 5$

54. $|x| = 8$

55. $|x| = 2$

56. $|x| = 0$

57. $|x| = -6$

58. $|x| = -1$

59. $|x| = 23$

60. $|x| = 105$

Choose the response that correctly completes each sentence. Assume that the variables represent integers. In each problem, give two examples that illustrate your reasoning.

61. $|a|$ is (never, sometimes, always) equal to a .

62. $|x|$ is (never, sometimes, always) equal to $-x$.

63. $|y|$ is (never, sometimes, always) equal to a positive integer.

64. $|x|$ is (never, sometimes, always) greater than x .

Applications

Solve. Represent each quantity with a signed integer.

65. The Alvin is a manned deep-ocean research submersible that has explored the wreck of the Titanic. The operating depth of the Alvin is 4500 meters below sea level.
66. The Mariana trench is the deepest known location on the Earth's ocean floor. The deepest known part of the Mariana Trench is approximately 11 kilometers below sea level.
67. Mount Everest is considered to be the highest mountain on Earth. Its peak reaches to a height of approximately 8844 meters.
68. The lowest temperature ever recorded was at the Vostok Station on Antarctica. On July 21, 1983, the temperature was approximately 128 degrees Fahrenheit below zero.
69. Terrence placed a drop of colored water on the center of a white strand of yarn and measured how much the color spread. Before placing the drop, he predicts that the color will spread no more than 3 inches away from the initial drop.
- Write an absolute value inequality using the variable x to represent the predicted spread.
 - Graph the solution set of integers for the absolute value inequality from part a. on the given number line, placing the initial drop at the point 0.

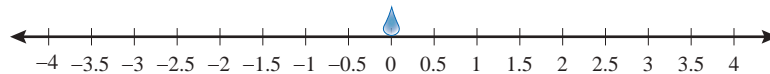

70. A ready-to-assemble bookcase contains wooden boards that have predrilled holes along with the screws and washers needed for assembly. The screws used to assemble the bookcase need to have a length of 38 mm with a tolerance of 2 mm. If the screw is too short, it won't be able to hold the pieces of wood together. If the screw is too long, it might stick out of the other end of the board.
- What is the largest length the screws can have before they are too long?
 - What is the smallest length the screws can have before they are too short?
 - Graph the tolerance of the screw. (Graph only the integers in the tolerance range.)

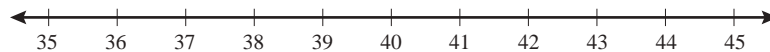

71. A freezer in a biology lab is supposed to be kept at 0°C . A lab assistant places a thermometer in the freezer and marks down the temperature every half hour. She records the following temperatures in degrees Celsius: $\left\{2, -\frac{1}{2}, \frac{1}{2}, 1\frac{1}{2}, -\frac{5}{2}\right\}$.
- Graph the set of temperatures on a number line.

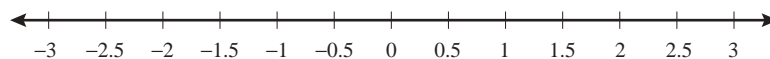

- Which value is the furthest away from 0?

72. During the manufacture of machine parts, certain measurements of the part must stay within a tolerance range or the part will be defective. The quality control manager determines that the maximum amount the length of a screw can vary from its targeted length of 15 millimeters and not be defective is 3 millimeters. If x represents the maximum acceptable difference in length from the target, either positive or negative, then $|x| = 3$.
- Solve the equation $|x| = 3$ to determine the maximum amounts that the screw length can vary from its target length.
 - What do the answers from part a. mean?
 - Determine the maximum and minimum lengths of a screw with the given tolerance range.
73. A carpenter needs to cut a board 1 meter long to create the backboard for a bookshelf. He has determined that the maximum amount the length of the board can vary from its required length and not cause structural issues is 5 mm. If x represents the maximum acceptable difference in length from the target, either positive or negative, then $|x| = 5$.
- Solve the equation $|x| = 5$ to determine the maximum amounts that the board length can vary from its target length.
 - What do the answers from part a. mean?
 - Determine the maximum and minimum lengths of a board with the given tolerance range.
74. Cynthia believes that the ideal daytime temperature for growing tomato plants is 77°F , and the plants will be okay as long as the temperature does not vary more than 7°F from that ideal temperature during the day.
- How low can the daytime temperature be to accommodate the tomato plant growth?
 - How high can the daytime temperature be to accommodate the tomato plant growth?
75. The following table shows the elevation of six California cities. (Sea level is defined to have 0 feet of elevation.)

| City | Elevation (in feet) |
|--------------|---------------------|
| Alameda | 50 |
| Death Valley | -282 |
| El Centro | -39 |
| Fresno | 296 |
| Salton City | -125 |
| Windsor | 118 |

- Which of these cities has an elevation farthest away from sea level?
- Which of these cities has an elevation closest to sea level?

Writing & Thinking

- Give one example each of the use of a positive number, a negative number, and the number zero (outside of a class).
- Explain, in your own words, how an expression such as $-y$ might represent a positive number.
- Compare and contrast absolute value with opposites.

Margin Exercise Answers

1. a. 15 b. -20 c. 5.9 d. $-\frac{11}{15}$ 2. a. 8 b. -7 c. -2.3 d. $\frac{4}{9}$ 3. a. -5 b. -3.6 4. a. -34 b. 7

3.2 Exercises

Concept Check

Fill-in-the-Blank. Complete each sentence using information found in this section.

1. If there is no sign in front of a number, it is understood to be a _____ number.
2. The sum of two positive real numbers is always _____.
3. The sum of two negative real numbers is always _____.
4. To find the sum of numbers with unlike signs, subtract their _____.
5. A statement that two expressions are equal is called a/an _____.

True/False. Determine whether each statement is true or false. If a statement is false, explain how it can be changed so the statement will be true. (**Note:** There may be more than one acceptable change.)

6. The sum of a positive number and a negative number is always positive.
7. When adding numbers with unlike signs, the results uses the sign of the number with the larger absolute value.
8. The sum of two positive numbers can equal zero.

Practice

Add. Reduce any fractions to lowest terms.

- | | |
|------------------|---------------------|
| 1. $4 + 9$ | 11. $-5 + (-3)$ |
| 2. $8 + (-3)$ | 12. $11 + (-2)$ |
| 3. $(-9) + 5$ | 13. $(-2) + (-8)$ |
| 4. $(-7) + (-3)$ | 14. $10 + (-3)$ |
| 5. $(-9) + 9$ | 15. $17 + (-17)$ |
| 6. $2 + (-8)$ | 16. $(-7) + 20$ |
| 7. $11 + (-6)$ | 17. $21 + (-4)$ |
| 8. $(-12) + 3$ | 18. $2.1 + (-4.6)$ |
| 9. $-18 + 5$ | 19. $-1.5 + (-3.1)$ |
| 10. $26 + (-26)$ | 20. $(-15) + (-3)$ |

21. $(-12)+(-17)$
22. $24+(-16)$
23. $-4+(-5)$
24. $-4.3+(-5.8)$
25. $-6.9+(-8.5)$
26. $(-6)+(-8)$
27. $9+(-12)$
28. $-12+9$
29. $(-33)+(-21)$
30. $(-21)+18$
31. $9.7+(-12.2)$
32. $-19.6+4.1$
33. $\frac{3}{14}+\frac{3}{14}$
34. $\frac{1}{10}+\frac{3}{10}$
35. $\frac{3}{4}+\left(-\frac{1}{8}\right)$
36. $\frac{5}{17}+\left(-\frac{15}{34}\right)$
37. $-\frac{5}{2}+\frac{3}{4}$
38. $-\frac{1}{6}+\frac{7}{15}$
39. $-3+4+(-8)$
40. $(-9)+(-6)+5$
41. $3.2+(-1.2)+(-2.5)$
42. $-5.3+1.9+(-0.7)$
43. $102+(-21)+(-5)$
44. $130+(-45)+(-32)$
45. $-210+(-200)+100$
46. $-18+(-15)+(-30)$
47. $35+2+(-5)+(-5)$
48. $-56+(-3)+(-1)+3$
49. $3.7+(-0.6)+1.4+(-2.2)$
50. $-7.5+(-2.4)+3.5+6.1$

Add. Be sure to find the absolute values first.

51. $13+|-5|$
52. $|-2|+(-5)$
53. $|-10|+|-4|$
54. $|-7|+(+7)$
55. $|-18|+|+17|$
56. $|-14|+|-6|$

 Add using a calculator.

57. $47+(-29)+66$
58. $56+(-41)+(-28)$
59. $2932+4751+(-3876)$
60. $(-8154)+2147+(-136)$
61. $(-16,945)+(-27,302)+(-53,467)$
62. $(-12,299)+15,631+(-47,558)$

Applications

Solve.

63. The table shows the reported profit or loss per quarter as reported by a business. Did the business have a total positive or negative profit for the year?

| Quarter | Profit/Loss |
|---------|-------------|
| 1 | \$15,000 |
| 2 | -\$8000 |
| 3 | -\$2000 |
| 4 | \$1000 |

64. For 2024, a business reports a profit of \$45,000 during the first quarter, a loss of \$8000 during the second quarter, a loss of \$2000 during the third quarter, and a profit of \$15,000 during the fourth quarter.
- Write an addition expression to represent the total profit made by the company in 2024. Do not simplify.
 - Simplify the expression from part a.
65. A climatologist takes weekly measurements of the height of a glacier near the North Pole. She keeps track of how much the glacier's height either increased or decreased during the week. Her results are presented in the table.

| Week | Increase | Decrease |
|------|----------|----------|
| 1 | 0.25 cm | |
| 2 | | 0.3 cm |
| 3 | | 0.1 cm |
| 4 | 0.17 cm | |

- Which measurements in the table would have a negative value?
 - Calculate the total change in height of the glacier over the four weeks. (**Hint:** Find the sum.)
 - Did the total height of the glacier increase or decrease by the end of the four weeks?
66. A passenger boards an elevator five floors below the ground floor. In this building, the ground floor is floor 0 and the floor above the ground floor is floor 1. The elevator goes up 8 floors before the passenger exits the elevator. At which floor did the passenger exit the elevator?
67. A submarine dives to a depth of 250 feet below the surface. It rises 75 feet before diving an additional 100 feet. What is the final depth of the submarine?
68. The temperature at 2 a.m. was -17°C . By 2 p.m., the temperature increased a total of 15°C . What was the temperature at 2 p.m.?
69. The tallest hill of a roller coaster is 282 feet above the ground. The hill descends 290 feet before leveling out. What is the lowest point of this hill of the roller coaster?
70. From the noon weather report to the evening weather report, the temperature changed from 72°F to 55°F . This situation can be represented by the equation $72 + t = 55$, where t represents the change in temperature. Determine which of the following values satisfies the equation: -13 , 13 , -17 , 17 .

71. At the end of the first inning of a baseball game, the home team had a score of 3 points. At the end of the ninth inning, the home team had a score of 11 runs. This situation can be represented by the equation $3 + x = 11$, where x represents the change in score. Determine which of the following values satisfies the equation: -8 , 8 , -4 , 4 .
72. Charlotte is a zoologist and part of her job is to keep track of the growth rate of a recently born koala. She writes in her report that the koala weighs 5.6 ounces more than it did when it was born a month ago, and the current weight is 28.4 ounces. This can be translated into a mathematical equation as $w + 5.6 = 28.4$, where w is the weight in ounces of the koala at birth. Determine the birth weight of the koala by substituting each of the following values into the equation to find the solution: 22.7 ounces, 23.2 ounces, 22.8 ounces, 23.8 ounces.
73. Part of Noam's job as an accountant is to keep track of the amount of money in the reserve fund. Last week, the fund started with \$1253.75 and only one transaction was made. This week, the fund started with \$1155.89. This change in value can be written in equation form as $\$1253.75 + t = \1155.89 , where t is the amount of the transaction. Determine the amount of the transaction by substituting each of the following values into the equation to find the solution: $-\$150.14$, $-\$97.86$, $-\$89.86$, $-\$97.14$.
74. Trevor is installing a hardwood floor in a customer's living room. The length of the room is $17\frac{3}{8}$ feet. Since the flooring comes in 12-foot pieces, Trevor needs to determine the length he must cut off of one of the boards to make it fit. The amount he needs to trim off of one of the boards can be represented by the equation $12 + (12 - r) = 17\frac{3}{8}$, where r is the amount to be removed from one of the boards. Determine the amount that needs to be trimmed off of one of the boards by substituting each of the following values into the equation to find the solution: $5\frac{5}{8}$ feet, $5\frac{3}{8}$ feet, $6\frac{5}{8}$ feet, $6\frac{3}{8}$ feet.

Writing & Thinking

75. Describe, in your own words, how the sum of the absolute values of two numbers might be 0. (Is this even possible?)
76. Describe in your own words the conditions under which the sum of two integers will be 0.

Choose the response that correctly completes each statement. In each problem, give two examples that illustrate your reasoning.

-
77. If x and y are real numbers, then $x + y$ is (never, sometimes, always) equal to 0.
78. If x and y are real numbers, then $x + y$ is (never, sometimes, always) negative.
79. If x and y are real numbers, then $x + y$ is (never, sometimes, always) positive.
80. If x is a positive real number and y is a negative real number, then $x + y$ is (never, sometimes, always) equal to 0.
81. If x and y are positive real numbers, then $x + y$ is (never, sometimes, always) equal to 0.
82. If x and y are both negative real numbers, then $x + y$ is (never, sometimes, always) equal to 0.
83. If x is a negative real number, then $-x$ is (never, sometimes, always) negative.
84. If x is a positive real number, then $-x$ is (never, sometimes, always) negative.

Example 6 Application: Calculating Net Change

Robert weighed 230 lb when he started to diet. The first month he lost 7 lb, the second month he gained 2 lb, and the third month he lost 5 lb. What was his weight after 3 months of dieting? What was his net change in weight?

Solution

His weight after 3 months can be calculated as follows.

$$\begin{aligned} 230 + (-7) + (+2) + (-5) \\ &= 223 + (+2) + (-5) \\ &= 225 + (-5) \\ &= 220\text{lb} \end{aligned}$$

His net change in weight was

$$230 - 220 = 10\text{ lb.}$$

Thus, Robert's weight after 3 months of dieting was 220 lb which was a net change of 10 lb.

Now work margin exercise 6.**Margin Exercise Answers**

1. a. -14 b. +9.2 2. a. -11 b. 0 c. 3.8 d. $-\frac{3}{4}$ e. $\frac{13}{10}$ 3. -19°F 4. -11,000 ft 5. 19 sales
6. 221 lb; 15 lb

6. Shawn weighed 236 lb when he started to diet. The first month he lost 8 lb, the second month he gained 3 lb, and the third month he lost 10 lb. What was his weight after 3 months of dieting? What was his net change in weight?

3.3 Exercises

Concept Check

Fill-in-the-Blank. Complete each sentence using information found in this section.

- The _____ is the opposite of a real number.
- On a horizontal number line, to move in the positive direction is to move to the _____.
- On a horizontal number line, to move in the negative direction is to move to the _____.
- To subtract b from a , add the _____ of b to a .
- To find the change in value between two numbers, take the end value and _____ the beginning value.
- The algebraic sum of several numbers is their _____.

True/False. Determine whether each statement is true or false. If a statement is false, explain how it can be changed so the statement will be true. (**Note:** There may be more than one acceptable change.)

- The sum of a number and its additive inverse is the number itself.
- The additive inverse of negative seven is seven.

9. We can think of addition of numbers as accumulating numbers.
 10. The expression “ $15 - 7$ ” can be thought of as “fifteen plus negative seven.”

Practice

Find the additive inverse (opposite) of each real number. See Example 1.

- | | |
|---------|-------------------|
| 1. 11 | 6. -3.4 |
| 2. 17 | 7. 0 |
| 3. -6 | 8. $\frac{9}{16}$ |
| 4. -2 | 9. $-\frac{5}{7}$ |
| 5. 4.7 | 10. -257 |

Subtract. Reduce fractions to lowest terms. See Example 2.

- | | |
|--------------------|-----------------------------------|
| 11. $8 - 3$ | 24. $5.3 - (-1.7)$ |
| 12. $5 - 7$ | 25. $-1.4 - 2.6$ |
| 13. $-4 - 6$ | 26. $-8.5 - 7.1$ |
| 14. $-18 - 17$ | 27. $1.6 - (-8.4)$ |
| 15. $3 - (-4)$ | 28. $1.5 - 2.3$ |
| 16. $5 - (-7)$ | 29. $\frac{2}{5} - \frac{3}{4}$ |
| 17. $-8 - (-11)$ | 30. $\frac{7}{15} - \frac{2}{15}$ |
| 18. $-14 - 2$ | 31. $\frac{5}{16} - \frac{9}{16}$ |
| 19. $0 - (-12)$ | 32. $\frac{5}{6} - \frac{7}{10}$ |
| 20. $-8 - 7$ | 33. $\frac{9}{20} - \frac{3}{8}$ |
| 21. $16 - (-8)$ | 34. $\frac{3}{14} - \frac{5}{6}$ |
| 22. $15 - 23$ | |
| 23. $2.8 - (-3.1)$ | |

Perform the indicated operation to find the net change in value. See Examples 5 and 6.

- | | |
|-----------------------|-------------------------|
| 35. $-6 + (-4) - 5$ | 40. $-8 - 5 - (-3)$ |
| 36. $-2 - 2 + 11$ | 41. $-7 - (-2) + 6$ |
| 37. $6 + (-3) + (-4)$ | 42. $-3 - (-3) + (-6)$ |
| 38. $-3 + (-7) + 2$ | 43. $9.7 - 1.6 - (8.1)$ |
| 39. $-5 - 2 - (-4)$ | 44. $-11.3 + 5.3 - 7.9$ |

Simplify the expression on each side of the blank and then fill in the blank with the proper symbol: $<$, $>$, or $=$.

45. $-6 + (-2)$ _____ $3 + (-8)$

46. $-4 - (-3)$ _____ $-4 + (-3)$

47. $5.1 - 8.2$ _____ $8.2 - 5.1$

48. $7 - (-3)$ _____ $-3 - 7$

49. $\frac{11}{2} + \left(-\frac{3}{4}\right)$ _____ $\frac{11}{2} - \frac{3}{4}$

50. $0 - 6$ _____ $0 - (-6)$

51. $-8 - (-8)$ _____ $-14 - 13$

52. $-\frac{7}{4} - \left(-\frac{3}{8}\right)$ _____ $\frac{1}{2} - \frac{7}{3}$

53. $-151 - 86$ _____ $-107 - 141$

54. $2.5 - 6.2$ _____ $-1.1 - 2.3$

 Use your calculator to simplify the expression on each side of the blank and then fill in the blank with the proper symbol: $<$, $>$, or $=$.

55. $648 - (-396)$ _____ $124 - 163$

56. $-19,824 - 23,417$ _____ $12,793 - (-14,387)$

57. $-43,931 - (-28,677)$ _____ $-(13,665 + 21,425)$

58. $-(24,295 + 13,107)$ _____ $-48,261 - (-16,276)$

Solve.

59. Find the difference between -5 and -6 . (**Hint:** Subtract the numbers in the order given.)

60. Find the difference between 30 and -12 . (**Hint:** Subtract the numbers in the order given.)

61. Subtract -3 from -10 .

62. Subtract -2 from 6 .

63. Subtract 13 from -13 .

64. Subtract 20 from -20 .

65. Find the sum of -12 and 6 . Then subtract -17 .

66. Find the sum of 11 and -13 . Then subtract 25 .

Applications

Solve.

67. At 2 p.m., the temperature was 76°F .
At 8 p.m., the temperature was 58°F .
What was the change in temperature?

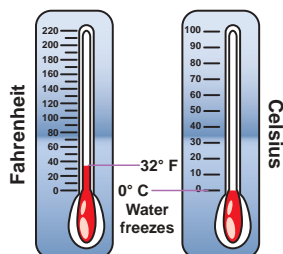

68. According to NASA, the temperature on the Earth's moon during the day is 260°F and during the night it is -280°F . What is the daily temperature change on the moon? ¹

69. On July 1, a certain stock opened at $\$53$ per share. One month later, on August 1, the stock opened at $\$60$ per share. Find the change in price of the stock.

¹ Source: NASA.gov

70. Mr. Meade is having a hard time selling his old car. He just slashed the price from \$3500 to \$2750. By how much did he change the price?

71. If you travel from the top of Mt. Whitney, elevation 14,505 ft, to the floor of Death Valley, elevation 282 ft below sea level, what is the change in elevation?

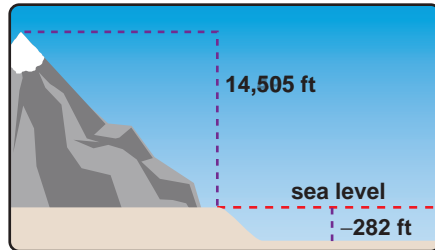

72. A submarine submerged 280 ft below the surface of the sea and fired a rocket that reached an altitude of 30,000 ft. What was the change in altitude of the rocket?

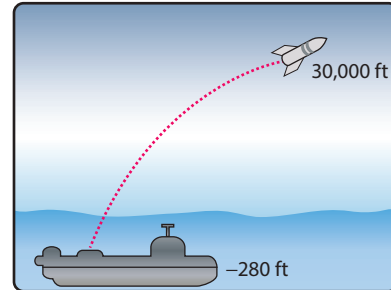

73. The highest temperatures recorded per month from July 2012 through June 2013 in Marquette, MI, are shown. Use the graph to answer the questions. ²

**Highest Recorded Temperatures,
July 2012-June 2013, Marquette, MI**

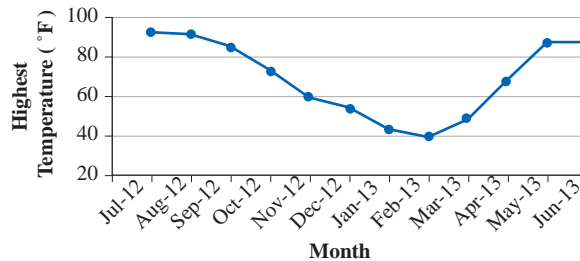

- Was the change in temperature negative or positive from October 2012 to November 2012?
- Was the change in temperature negative or positive from April 2013 to May 2013?
- Between which two months did the smallest change in high temperature occur?
- Between which two months did the largest change take place?

74. James decided to take a road trip from Wilmington, NC, to Los Angeles, CA. The total distance of the trip is 2590 miles. He stops for a break after he has traveled 438 miles. How many more miles must James travel before he reaches Los Angeles?

75. The Kingston Construction Co. made a bid of \$7,043,272 to build a stretch of freeway, but the Beach City Construction Co. made a lower bid of \$6,792,868. How much lower was the Beach City bid?

76. A couple sold their house for \$175,000. They paid the realtor \$9100, and other expenses of the sale came to \$800. If they owed the bank \$126,000 for the mortgage, what were their net proceeds from the sale?

77. If you had \$980 in your checking account and you wrote a check for \$358 and made a deposit of \$225, what would be the balance in the account?

² Source: weather.gov

78. In pricing a four-door car, Pat found she would have to pay a base price of \$30,500 plus \$2135 in taxes and \$1006 for license fees. For a two-door sedan car of the same make, she would pay a base price of \$25,000 plus \$1750 in taxes and \$825 for license fees. Including all expenses, how much cheaper was the two door model?
79. The cost of repairing Sylvia's dishwasher would be \$350 for parts (including tax) plus \$105 for labor. To buy a new dishwasher, she would pay \$670 plus \$40 in sales tax, and a friend of hers would pay her \$90 for her old dishwasher. How much more would Sylvia have to pay to buy a new dishwasher than to have her old one repaired?
80. During a football game, the home team gained 28 yards, gained 9 yards, lost 2 yards, gained 5 yards, gained 1 yard, gained 10 yards, lost 5 yards on a penalty, and lost 11 yards. What was the team's net yardage on this possession of the football?
81. Beginning at a temperature of 10°C , the temperature in a scientific experiment was measured hourly for four hours. It dropped 5°C , dropped 8°C , dropped 6°C , then rose 3°C . What was the final temperature recorded?
82. Harry went on a diet for 5 weeks. During those 5 weeks, Harry lost 5 pounds, gained 3 pounds, lost 2 pounds, lost 4 pounds, and gained 1 pound. What was his total loss (or gain) for the 5 weeks? If he weighed 210 pounds when he started the diet plan, what did he weigh at the end of the 5-week period?
83. In a 5-day week the NASDAQ posted a gain of 38 points, a loss of 65 points, a loss of 32 points, a gain of 10 points, and a gain of 15 points. If the NASDAQ started the week at 2350 points, what was the market at the end of the week?
84. Many personal securities accounts have a cash fund to receive dividends. The investor is free to withdrawal money from that account, as well as make deposits. Unlike regular checking accounts, there is no overdraft penalty when the balance is less than zero dollars; instead, a nominal interest rate is charged until the balance becomes positive. In addition, this type of account will accrue interest on positive balances. At the beginning of an account period the balance is \$3520, and five transactions are made before the next statement is posted as follows: \$300 deposit, \$2500 withdrawal, \$1800 withdrawal, \$253 deposit, and \$450 withdrawal. What is the balance at the close of this accounting period?
85. A family has a rain cistern to collect rainwater runoff from the roof to water their lawn and garden. When it rains, the garden does not need to be watered, and the cistern just collects additional water for future use. When it doesn't rain, the stored water is needed to water the plants. At the beginning of a five-week period, the cistern has 873 gallons of water, and the net intake/outflow was noted at the end of each week. First it rose by 461 gallons, then it dropped by 349 gallons, then it dropped by 217 gallons, followed by a 275 gallon increase, and a 177 gallon increase. How many gallons does the cistern contain after this five week period?
86. John goes to a casino in Las Vegas and plays six games. His wins and losses for each respective game was \$15 gained, \$50 lost, \$20 lost, \$80 gained, \$100 lost, and \$40 lost. What was John's net gain or loss?

87. The population of San Bernardino County, California, in 2003 was 197,126. The population shift for the next five years is shown on the chart below.³

| Year | Population Shift |
|------|------------------|
| 2004 | +2696 |
| 2005 | -554 |
| 2006 | +162 |
| 2007 | -955 |
| 2008 | +105 |

- a. What was the change in population in that five year period?
- b. What is the population in 2008?
88. The manager of a music store is required to keep track of the inventory for each instrument that the store rents out. The store had twenty-five trumpets in stock at the beginning of the school year before twelve trumpets were rented out. Five trumpets were returned by the end of the first semester. Seven additional trumpets were rented at the beginning of the second semester. Eight trumpets were returned at the end of the second semester.
- a. How many trumpets did the store have in stock at the end of the second semester?
- b. What was the change in the trumpet inventory between the beginning of the school year and the end of the second semester?
89. A chemist is determining the water content of different foods in his lab by completely dehydrating food samples (that is, he is removing all of the water). He started an experiment with a fresh white potato that had a mass of 115 g. The mass of the potato after being dehydrated was 24.15 g. This situation can be described by the equation $115 - w = 24.15$, where w is the amount of water mass the potato lost in grams. Determine the water mass of the fresh potato by substituting each of the following values into the equation to find the solution: 90.15 g, -90.15 g, 90.85 g, -90.85 g
90. Grace keeps track of her grade average in Introduction to Anthropology throughout the semester. After the first exam, she had a 93.5%. A project decreased her average grade by 1.5%. The next exam decreased her grade by 4.7%. A term paper increased her grade by 2.3%. The final increased her grade by 3.1%.
- a. What was Grace's grade average at the end of the semester?
- b. What was the change in Grace's grade average during the semester?
91. Beginning with a temperature of 8 °F above zero, the temperature was measured hourly for 4 hours. It rose 3 °F, dropped 7 °F, dropped 2 °F, and rose 1 °F. What was the final temperature recorded?
92. George and his wife went on a diet plan for 5 weeks. During these 5 weeks, George lost 5 pounds, gained 2 pounds, lost 4 pounds, lost 6 pounds, and gained 3 pounds. What was his total loss or gain for these 5 weeks? If he weighed 225 pounds when he started the diet, what did he weigh at the end of the 5-week period?
93. In a 5-day week, the NASDAQ stock market posted a gain of 145 points, a loss of 100 points, a loss of 82 points, a gain of 50 points, and a gain of 25 points. If the NASDAQ started the week at 4200 points, what was the market at the end of the week?

3 Source: www.idcide.com/citydata/ca/san-bernardino.htm

94. In 10 running plays in a football game, the halfback gained 2 yards, gained 12 yards, lost 5 yards, lost 3 yards, gained 22 yards, gained 3 yards, gained 7 yards, lost 2 yards, gained 4 yards, and gained 45 yards. What was his net yardage for the game? This was a good game for him, but not his best.

Writing & Thinking

95. Explain, in your own words, how to find the difference between a positive and a negative number.
96. What is the additive inverse of 0? Why?
97. Under what conditions can the difference between two negative numbers be a positive number?
98. Explain how a subtraction problem is changed to an addition problem. Give an example.

Solution

Using a calculator, the sum of the speeds is 1008 mph.

Dividing by 15 gives the average speed.

$$1008 \div 15 = 67.2 \text{ mph}$$

The average speed was 67.2 mph.

Now work margin exercise 8.**Margin Exercise Answers**

1. a. -28 b. -28 c. -40 d. -35 e. -6.4 f. $-\frac{7}{2}$ 2. a. +24 b. $+\frac{22}{15}$ c. +17.5 d. +48
 3. a. 0 b. 0 4. a. 6 b. -6 c. -6 d. 6 e. undefined f. 0 5. a. 12 b. $-\frac{7}{4}$ c. -2.1 d. 2.9
 6. 4 °F 7. 79 8. 47.7 mph

3.4 Exercises

Concept Check

Fill-in-the-Blank. Complete each sentence using information found in this section.

- The value found by adding numbers and then dividing the sum by the number of items in the set is the _____ (or _____) of the numbers.
- When a positive number and negative number are multiplied, the result is a _____ number.
- If two positive numbers are being multiplied, the product is a _____ number.
- If two negative numbers are being divided, the quotient is a _____ number.
- When zero is divided by a nonzero number, the answer is always ____.
- The quotient of a number divided by zero is _____.

True/False. Determine whether each statement is true or false. If a statement is false, explain how it can be changed so the statement will be true. (**Note:** There may be more than one acceptable change.)

- If a negative number is divided by a positive number, the result will be a negative number.
- The product of zero and a number is zero.
- If two numbers have the same sign, both the product and the quotient of the two numbers will be negative.
- The mean of a set of numbers is always positive.

Practice

Multiply. Reduce fractions to lowest terms. See Examples 1 through 3.

- | | | |
|-----------------|--------------------------|--|
| 1. $4(-3)$ | 13. $10(-7)$ | 24. $(-2.6)(-0.2)$ |
| 2. $6(-5)$ | 14. $(-5)(12)$ | 25. $-\frac{3}{8} \cdot \frac{4}{9}$ |
| 3. $12 \cdot 4$ | 15. $(-2)(-3)(-4)$ | 26. $\frac{4}{5} \cdot \frac{-3}{14}$ |
| 4. $19 \cdot 3$ | 16. $(-6)(-3)(-9)$ | 27. $\frac{-4}{5} \cdot \frac{-9}{2}$ |
| 5. $(-8)(-7)$ | 17. $-8 \cdot 4 \cdot 9$ | 28. $-\frac{3}{4} \cdot -\frac{6}{7}$ |
| 6. $(-11)(-2)$ | 18. $(-3)(2)(-3)$ | 29. $-4 \cdot \frac{3}{5}$ |
| 7. $-3 \cdot 7$ | 19. $(-7)(-16)(0)$ | 30. $-7 \cdot \frac{5}{6}$ |
| 8. $-7 \cdot 5$ | 20. $-9 \cdot 0 \cdot 4$ | 31. $\frac{5}{2} \cdot \frac{-15}{10} \cdot \frac{6}{5}$ |
| 9. $(-14)(-4)$ | 21. $(-2)(4.5)$ | 32. $\frac{-4}{7} \cdot \frac{2}{5} \cdot \frac{-2}{13}$ |
| 10. $(-11)(-6)$ | 22. $(-5)(-3.8)$ | |
| 11. $(-13)(-2)$ | 23. $4.3(-1.7)$ | |
| 12. $(-8)(-9)$ | | |

Divide. Reduce fractions to lowest terms. Round answers with decimals to the nearest tenth. See Examples 4 and 5.

- | | | |
|-----------------------|-----------------------|--|
| 33. $\frac{-8}{-2}$ | 43. $\frac{-34}{2}$ | 53. $\frac{2.99}{-1.3}$ |
| 34. $\frac{-20}{-10}$ | 44. $\frac{-36}{9}$ | 54. $\frac{2.8}{-1.4}$ |
| 35. $\frac{-30}{5}$ | 45. $\frac{-3}{0}$ | 55. $\frac{-2}{15} \div \frac{8}{5}$ |
| 36. $\frac{-51}{3}$ | 46. $\frac{0}{-7}$ | 56. $\frac{-3}{5} \div \frac{-9}{10}$ |
| 37. $\frac{-26}{-13}$ | 47. $\frac{-60}{-12}$ | 57. $\frac{6}{11} \div \frac{4}{3}$ |
| 38. $\frac{-91}{-7}$ | 48. $\frac{-48}{-16}$ | 58. $\frac{-10}{3} \div \frac{-7}{5}$ |
| 39. $\frac{0}{6}$ | 49. $\frac{-4.8}{8}$ | 59. $\frac{-9}{14} \div \frac{54}{35}$ |
| 40. $\frac{16}{0}$ | 50. $\frac{-5.6}{7}$ | 60. $\frac{45}{8} \div \frac{35}{12}$ |
| 41. $\frac{39}{-13}$ | 51. $\frac{-4}{-0.2}$ | |
| 42. $\frac{44}{-4}$ | 52. $\frac{-3}{-8}$ | |

Determine whether each statement is true or false. If a statement is false, rewrite it in a form that is true. (There may be more than one correct new form.)

61. $(-4)(6) \geq 3 \cdot 8$

66. $7 + 8 > (-10) + (-5)$

62. $(-7)(-9) \leq 3 \cdot 21$

67. $-\frac{2}{3} + \frac{1}{2} \leq \frac{1}{2} - \frac{1}{4}$

63. $-\frac{3}{4} \cdot \frac{5}{8} = \frac{15}{16} \left(-\frac{1}{2}\right)$

68. $1.7 + (-3.9) < (-1.4) + (-4.2)$

64. $(-6.0)(9.1) = (6.1)(-9.0)$

69. $(-4)(9) = (-24) + (-12)$

65. $6(-3) > (-14) + (-4)$

70. $14 + 6 \leq (-2)(-10)$

 Use a graphing calculator to find the value of each expression. Round quotients to the nearest hundredth, if necessary. Remember the negative sign $(-)$ is next to (ENTER) . For example, $-14.8 \div (-5)$ would appear as follows.

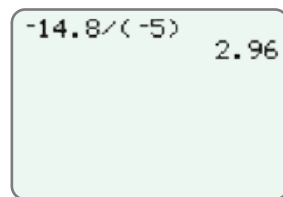

71. $(27)(-24)(-180)$

77. $(-52 - 30 - 40 - 60) \div 4$

72. $(-461)(-45)(-17)$

78. $72 \div (15 - 22)$

73. $(54)(-17)(-24)$

79. $95 \div (-3 - 7)$

74. $(-77,459) \div 29$

80. $-15.3 \div (-5.4)$

75. $(-62,234) \div (-37)$

81. $(-13.4)(-2.5)(-1.63)$

76. $(-35 - 45 - 56) \div 3$

82. $(-2.5)(-3.41)(-10.6)$

Applications

Solve.

83. Find the mean of the following set of integers: $-10, 15, 16, -17, -34,$ and -42 .

84. Find the mean of the following set of integers: $-72, -100, -54, 82,$ and -96 .

85. The Math Club members decided to attend the national meeting of the NCTM (National Council of Teachers of Mathematics) and had a book sale to raise money for the event. Registration fees were \$85 per member and the club had 35 members. How much money did the club need to raise for registration fees?

86. If one regular pack of candy contains 250 calories, how many calories are there in 37 packs of the same candy?

87. A sandwich shop buys 372 loaves of bread for the week. If each loaf of bread has 24 slices, how many slices of bread were purchased?

88. Students at the local community college must pay \$83 for a math textbook. If there are 43 students in the class, find the total amount the class will spend on textbooks.

89. Your company bought 18 new cars, each with blind-spot monitoring and backup cameras, at a price of \$24,600 per car. How much did your company pay for these cars?
90. According to the US Fish and Wildlife Service, migratory birds are imported at a value of about \$19 each. Suppose that about 800,000 live birds are imported each year. What is the total value of these imported birds?
91. A mother has 12 cookies that she will equally divide among 4 children. How many cookies will each child get?
92. Seven students sold a total of 392 raffle tickets. Assuming that each student sold the same number of raffle tickets, how many tickets did each student sell?
93. The Cedarville Baseball Camp has 198 campers. How many 9-member teams can this camp have?
94. Jane Scott tutors students in reading and makes \$25 per student. If she makes \$475 in a week, how many students did she tutor?
95. One pint of Ben and Jerry's Crème Brûlée Ice Cream has 68 grams of fat. If there are 4 servings per pint, how many grams of fat are in each serving? ¹
96. If one person can paint a small house in 48 hours, how long will it take a crew of 8 people to paint the house, assuming that all 8 work at the same speed, and do not interfere with each other?
97. For 2021–2022, the average tuition cost for four years at a public 4-year institution was \$42,960. If tuition did not increase each year, how much would you pay per year for the four years you were in college? ²
98. Smithfield High School paid \$29,022 for six pianos. How much did each piano cost?
99. The area of every NFL football field is 57,600 square feet. If a bag of grass seed covers 50 square feet, how many bags of grass seed will be needed to cover one grass football field? ³
100. US Astronaut Peggy Whitson orbited the Earth 6032 times during her space flights on the International Space Station. If the International Space Station orbits the Earth 16 times a day, how many days was Peggy Whitson in space? ⁴
101. A community has 5978 square feet available for individual gardens that will be evenly distributed among 14 people. How much space will each person get?
102. Thirteen men purchase a boat together. If the cost of the boat is \$33,462, how much will each man contribute if each contributes an equal amount?
103. A large chicken farm produces 65,076 eggs during a typical week. How many dozen eggs does this represent? (**Note:** 1 dozen = 12 eggs)

1 Source: Ben and Jerry's

2 Source: www.collegeboard.com

3 Source: National Football League

4 Source: National Aeronautics and Space Administration

104. 262,800 pounds of pasta is served every year at Mama Melrose's Ristorante Italiano at Disney MGM Studios. How many pounds of pasta are served every day, assuming there are 365 days in each year? ⁵
105. Katelyn is having a birthday party and has invited 11 friends. For lunch, Katelyn's parents bought 3 large pizzas that have 8 slices per pizza. How many slices of pizza will each child get? (Assume only Katelyn and her 11 friends are eating the pizza.)
106. The costs of a one-way flight from Baltimore, MD, to Orlando, FL, for seven different flight times are as follows: \$73, \$171, \$147, \$87, \$89, \$111, \$100. What is the average cost of a flight from Baltimore to Orlando? ⁶
107.  The numbers of fatal motor vehicle accidents in the United States each year from 2005 to 2015 are as follows: 39,252; 38,648; 37,435; 34,172; 30,862; 30,296; 29,867; 31,006; 30,202; 30,056; 32,166. What was the average number of fatal accidents in the United States per year from 2005 to 2015? (Round your answer to the nearest tenth.) ⁷
108. During one day, Sebastian made several transactions with his checking account. He deposited \$150 at the beginning of the day, bought groceries for \$45.50, filled his car with gas for \$39, bought tutoring supplies for \$15, and deposited \$120 at the end of the day.
- Which amounts are credits to Sebastian's account? Be sure to include the sign.
 - Which amounts are debits to his account? Be sure to include the sign.
 - What was the average transaction amount that Sebastian made during the day? (**Hint:** Be sure to use the amounts from parts a. and b.)
109. An auto tire manufacturer recommends using 35 psi of air pressure in their standard tires. A tire has a leak that causes the air pressure of the tire to change at a rate of -2 psi per hour.
- How much will the tire's air pressure change after 4 hours?
 - A tire with a standard air pressure of 35 psi is considered to be flat when it has only 24.5 psi of pressure. What change in air pressure will cause the tire to be considered flat?
 - How long will it take the tire to lose the amount of air pressure determined in part b.?

⁵ Source: www.diningindisney.com

⁶ Source: Expedia.com

⁷ Source: NHTSA

110.  In King Salmon, Alaska, the lowest monthly temperature was recorded for several months as shown in the table. Use the data to answer the following questions. Round your answers to the nearest hundredth.⁸

Lowest Monthly Temperature
in King Salmon, Alaska

| Month | Temperature |
|---------------|-------------|
| October 2012 | 4 °F |
| November 2012 | −4 °F |
| December 2012 | −22 °F |
| January 2013 | −11 °F |
| February 2013 | −14 °F |
| March 2013 | −18 °F |

- What was the average of the low temperatures over these months?
 - The lowest temperature recorded for April 2013 was 1 °F. Will the average low temperature increase or decrease if this data value is now used in calculating the average? Do not calculate the average.
 - Find the average lowest temperature from October 2012 through April 2013. (**Hint:** part b. gives the lowest temperature for April 2013.)
 - How do the average temperatures from parts a. and c. compare?
 - What is the range of the lowest monthly temperatures for the months given in the table?
111. Twenty business executives made the following numbers of telephone calls during one week. Find the mean number of calls (to the nearest tenth) made by these executives.

| | | | | |
|----|----|----|----|----|
| 20 | 16 | 14 | 11 | 51 |
| 40 | 36 | 28 | 52 | 25 |
| 18 | 16 | 42 | 49 | 12 |
| 18 | 22 | 33 | 9 | 19 |

112. The blood calcium level (in milligrams per deciliter) for 20 patients was reported as follows.

| | | | | |
|-----|------|------|-----|-----|
| 8.2 | 10.2 | 9.3 | 8.5 | 7.3 |
| 9.7 | 9.6 | 8.3 | 9.8 | 9.1 |
| 9.4 | 11.1 | 10.0 | 8.5 | 9.9 |
| 8.6 | 10.2 | 9.4 | 9.1 | 9.2 |

Find the mean blood calcium level (to the nearest hundredth) for these patients.

113. Fifteen students scored the following scores on an exam in accounting: 1 scored 67, 4 scored 73, 3 scored 77, 2 scored 80, 3 scored 88, and 2 scored 93. What was the average score for these students?
114. On an exam in history, a class of twenty-one students had the following test scores: 4 scored 65, 3 scored 70, 6 scored 78, 2 scored 82, 1 scored 85, 3 scored 91, and 2 scored 95. What was the mean score (to the nearest tenth) on this test for the class?

The frequency of a number is a count of how many times that number appears. In statistics, data is commonly given in the table form of a frequency distribution as illustrated. To find the mean, multiply each number by its frequency, add these products, and divide the sum by the sum of the frequencies.

115.  The heights of the top 30 NBA scorers for the 2021–2022 season are listed in the frequency table. Find the mean height for these men. ⁹

| | | | | | | | | | | | | | |
|---------------------------|----|----|----|----|----|----|----|----|----|----|----|----|----|
| Height (in inches) | 73 | 74 | 75 | 76 | 77 | 78 | 79 | 80 | 81 | 82 | 83 | 84 | 85 |
| Frequency | 3 | 3 | 1 | 2 | 3 | 2 | 3 | 4 | 1 | 2 | 4 | 1 | 1 |

116. The students in a psychology class were asked the number of books that they had read in the last month. The following frequency distribution indicates the results. Find the mean number of books read (to the nearest tenth) by these students

| | | | | | | |
|------------------------|---|---|---|---|---|---|
| Number of Books | 0 | 1 | 2 | 3 | 4 | 5 |
| Frequency | 3 | 2 | 6 | 4 | 2 | 1 |

117. The following bar graph shows the approximate amounts of time per week spent by people watching broadcast TV or a streaming service for six groups (by age and sex) of people 18 years of age and older. What is the average amount of time per week people over the age of 18 spend watching broadcast TV or a streaming service? (Assume each group has the same number of people.)

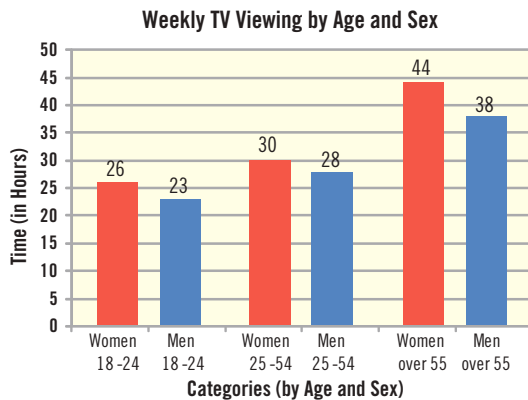

118. The following pictograph shows the number of phone calls received by a 1-hour radio talk show in Seattle during one week. (Not all calls actually get on the air.) What was the mean number of calls per show received that week?



9 Source: NBA

- 119.** The following bar graph shows the area of each of the five Great Lakes. Lake Superior, with an area of about 31,700 square miles, is the world's largest fresh water lake. What is the mean size of these lakes?

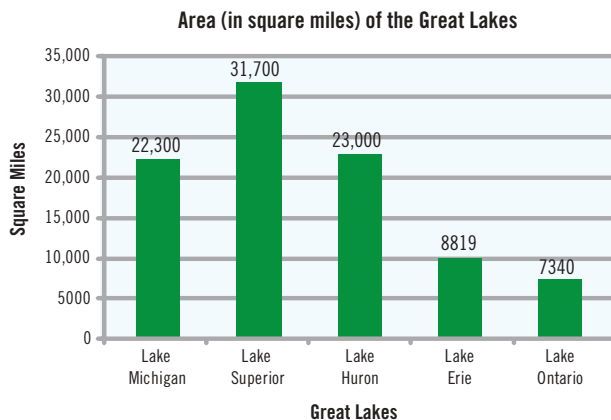

Writing & Thinking

- 120.** If you multiply an odd number of negative numbers together, do you think that the product will be positive or negative? Explain your reasoning.
- 121.** If you multiply an even number of negative numbers together, do you think that the product will be positive or negative? Explain your reasoning.
- 122.** Explain the conditions under which the quotient of two numbers is 0.
- 123.** Explain, in your own words, why division by 0 is not a valid arithmetic operation.

3.5 Exercises

Concept Check

Fill-in-the-Blank. Complete each sentence using information found in this section.

- When following the rules for order of operations, simplify within _____ first.
- Start by simplifying the _____ grouping symbol and working outward.
- When performing multiplication and division, move from _____ to _____.
- When performing addition and subtraction, perform the operations in the order they _____, moving left to right.
- A negative sign in front of a variable means the variable is being multiplied by _____.
- Parentheses, brackets, and braces are known as _____ symbols.

True/False. Determine whether each statement is true or false. If a statement is false, explain how it can be changed so the statement will be true. (**Note:** There may be more than one acceptable change.)

- If there are no grouping symbols, multiplication should always be performed before addition.
- When following the rules for order of operations, powers indicated by exponents should be evaluated last.
- The square root symbol is a grouping symbol.
- A well-known mnemonic device for remembering the rules for order of operations is SADMEP.

Practice

Simplify.

- $24 \div 4 \cdot 6$
 - $24 \cdot 4 \div 6$
- $20 \div 5 \cdot 2$
 - $20 \cdot 5 \div 2$
- $15 \div (-3) \cdot 3 - 10$
- $20 \cdot 2 \div 2^2 + 5(-2)$
- $3^2 \div (-9) \cdot (4 - 2^2) + 5(-2)$
- $4^2 \div (-8)(-2) + 3(2^2 - 5^2)$
- $14 \cdot 3 \div (-2) - 6(4)$

8. $6(13-15)^2 \cdot 8 \div 2^2 + 3(-1)$
9. $-10 + 15 \div (-5) \cdot 3^2 - 10^2$
10. $16 \cdot 3 \div (2^2 - 5)$
11. $2 - 5[(-20) \div (-4) \cdot 2 - 40]$
12. $9 - 6[(-21) \div 7 \cdot 2 - (-8)]$
13. $(7-10)[49 \div (-7) + 20 \cdot 3 - (-10)]$
14. $(9-11)[(-10)^2 \cdot 2 + 6(-5)^2 - 10^2 + 3 \cdot 5]$
15. $8 - 9[(-39) \div (-13) + 7(-2) - (-2)^2]$
16. $6 - 20[(-15) \div 3 \cdot 5 + 6 \cdot 2 \div 3]$
17. $|16 - 20|[32 \div |3 - 5| - 5^2]$
18. $|10 - 30|[4^2 \cdot |5 - 8| \div (-2)^2 + |17 - 18|]$
19. $(-10) + (-2) + |2 - 4|$
20. $|16 - 20| + (-10)^2 + 5^2$
21. $\frac{3}{8} \cdot \frac{4}{5} + \frac{1}{15}$
22. $\frac{1}{4} \cdot \frac{12}{15} + \frac{2}{7}$
23. $\frac{1}{3} \div \frac{1}{2} - \frac{5}{6} \cdot \frac{3}{4}$
24. $\frac{2}{9} \div \frac{14}{3} - \frac{1}{6} \cdot \frac{4}{7}$
25. $\left(\frac{5}{6}\right)^2 \div \frac{5}{12} - \frac{3}{8}$
26. $\left(\frac{2}{5}\right)^2 \cdot \frac{5}{8} + \frac{1}{5} \div \frac{3}{4}$
27. $\frac{7}{6} \cdot 2^2 - \frac{2}{3} \div \frac{1}{2}$
28. $\frac{3}{4} \div 3^2 - 4\left(\frac{1}{2}\right)^2$
29. $\left(-\frac{3}{4}\right) \div \left(-\frac{3}{5}\right) \cdot \frac{7}{8} + \frac{3}{16}$
30. $\left(-\frac{2}{3}\right) \div \frac{7}{12} - \frac{2}{7} + \left(-\frac{1}{2}\right)^2$
31. $\left(-\frac{9}{10}\right) + \frac{5}{8} \cdot \frac{4}{5} \div \frac{6}{10} + \frac{2}{3}$
32. $\frac{5}{8} \div \frac{5}{2} + \left(-\frac{1}{2}\right)^2 \cdot \frac{2}{5}$
33. $-0.7 - 8.5 \div 1.7$
34. $-0.4 - 2.6 \cdot 1.5$
35. $(3.1 + 1.1) \div (5.7 - 6.9)$
36. $(3.2 - 6.5) \cdot 2^2$
37. $-15 \div \left(\frac{1}{4} - \frac{7}{8}\right)$
38. $-12 \div \left(\frac{1}{2} + \frac{1}{10}\right)$
39. $(-5 - 7) \div -4 - 8$
40. $4(-2)^2 - 10 \div 5 + 1$

Solve.

41. Find the average of the five numbers: $-7, 8, -3, 5,$ and $2.$
42. Find the average of the six numbers: $-1, -2, -3, 3, 2,$ and $1.$
43. If the square of $\frac{7}{8}$ is subtracted from the square of $\frac{3}{4}$, what is the difference?
44. Find the quotient if the sum of $\frac{1}{5}$ and $\frac{2}{15}$ is divided by the difference between $\frac{7}{8}$ and $\frac{3}{4}.$

 Use a graphing calculator to evaluate each expression.

45. $3.4 \div 4 + 5 \cdot 8.32$
46. $8.1 \div 5 + 16.3 \cdot 7$
47. $0.75 \div 1.5 + 7 \cdot 3.1^2$
48. $1.05 \div (-3) \cdot 3.7 - 1.1^2$

49. $6.32 \cdot 8.4 \div 16.8 + 3.5^2$

50. $(82.7 + 16.2) \div (14.83 - 19.83)^2$

Applications

Solve.

51. Madeline sells homemade aprons online and needs to determine how to charge for each apron. To create each apron, she spends \$8.50 on supplies and it takes her $1\frac{1}{4}$ hours to cut and sew each one. Madeline wants to charge \$11 per hour of work plus the cost of supplies.
- Write an expression to describe how much each apron will cost.
 - Evaluate the expression to determine the selling cost of each apron.
 - Madeline will sew a name or initials onto the apron for an additional charge of \$1.75 per letter. If Kathy orders an apron and wants her name sewn onto it, how much will the apron cost?
52. The Matthews family, a family of 4, is planning a trip to New York City. During their visit, they want to see the Broadway play *Beetlejuice*. The tickets cost \$102 each. The Matthews purchase the tickets online and the website charges a service fee of \$7.50 per ticket. The website is running a sale where the Matthews can get 10% off of their entire purchase.
- Write an expression to describe how much of a discount the Matthews will receive on their purchase.
 - What is the final purchase price of the tickets?
53. Dennis overdrew his checking account and ended up with a balance of $-\$42$. The bank charged a \$35 overdraft fee and an additional \$5 fee for every day the account was overdrawn. Dennis left his account overdrawn for 3 days.
- Write an expression to show the balance of Dennis's checking account after 3 days.
 - Simplify the expression in part a. to find the balance of Dennis's checking account after 3 days.
54. Camila is a seamstress and is creating bridesmaid dresses. She has 115 yards of satin fabric. For each dress, the skirt requires 3 yards of satin and the bodice requires 1.5 yards of satin. She plans to make 20 dresses.
- Write an expression to show how much fabric Camila will have left over after making the dresses.
 - Simplify the expression in part a. to determine how much fabric Camila will have left over.
 - Camila wants to make shawls from the leftover fabric. Each shawl requires 1.25 yards of satin. Can she make 15 shawls?

55. During harvest season, farmers donate fresh food to a local food kitchen. To make sure the food doesn't spoil, the food kitchen distributes the food between themselves and 5 other food kitchens in the area. One farmer donates $12\frac{1}{2}$ pounds of potatoes, another farmer donates $15\frac{3}{4}$ pounds of potatoes, and a third farmer donates $11\frac{3}{4}$ pounds of potatoes. The food kitchen finds that $1\frac{1}{4}$ pounds of the donated potatoes are rotten.
- Write an expression to show how many pounds of potatoes each food kitchen will receive.
 - Simplify the expression from part a. to determine how many pounds of potatoes each food kitchen will receive.
56. Casey wants to put together some back-to-school gifts for local families in need. She has contacted companies directly and worked out deals to get backpacks for \$10 each, headphones for \$4 each, a pack of crayons for \$0.50 each, and a combo pack consisting of a notebook, a folder, and a pencil for \$1 per combo pack.
- Write an expression to describe how much each gift will cost Casey, assuming each gift consists of one backpack, one pair of headphones, one pack of crayons, and 2 combo packs.
 - How much will Casey spend in total if she is able to give 5 back-to-school gifts?
57. You and three friends are planning a weekend trip. You plan to share a hotel room that is \$225 a night, go on a city tour that costs \$20 per person, and go to a baseball game that is \$15 per person.
- Write an expression to describe the total cost of the trip, assuming you are all staying for two nights.
 - If you split the cost equally, how much will each person pay for the trip, not counting additional expenses?

Writing & Thinking

58. Explain, in your own words, why the following expression cannot be evaluated.

$$(24 - 2^4) + 6(3 - 5) \div (3^2 - 9)$$

59. Consider any number between 0 and 1. If you square this number, will the result be larger or smaller than the original number? Is this always the case? Explain.
60. Consider any number between -1 and 0. If you square this number, will the result be larger or smaller than the original number? Is this always the case? Explain.

2. State the property illustrated and show that the statement is true for the value given for the variable.

a. $x + 21 = 21 + x$
given that $x = -7$

b. $(5 \cdot 4)x = 5(4x)$
given that $x = 2$

c. $11(y + 3) = 11y + 33$
given that $y = -4$

Example 2 Identifying Properties of Addition and Multiplication

For each of the following equations, state the property illustrated, and show that the statement is true for the value given for the variable by substituting the value in the equation and evaluating.

a. $x + 14 = 14 + x$ given that $x = -4$

b. $(3 \cdot 6)x = 3(6x)$ given that $x = 5$

c. $12(y + 3) = 12y + 36$ given that $y = -2$

Solution

a. The commutative property of addition is illustrated.

$$(-4) + 14 = 10 \text{ and } 14 + (-4) = 10$$

b. The associative property of multiplication is illustrated.

$$(3 \cdot 6) \cdot 5 = 18 \cdot 5 = 90 \text{ and } 3 \cdot (6 \cdot 5) = 3 \cdot 30 = 90$$

c. The distributive property is illustrated.

$$12(-2 + 3) = 12(1) = 12 \text{ and } 12(-2) + 36 = -24 + 36 = 12$$

Now work margin exercise 2.

Margin Exercise Answers

1. a. Associative property of multiplication b. Distributive property c. Zero-factor law
d. Associative property of addition e. Commutative property of multiplication
f. Additive identity g. Additive inverse 2. a. Commutative property of addition $(-7) + 21 = 14$ and $21 + (-7) = 14$ b. Associative property of multiplication $(5 \cdot 4) \cdot 2 = 40$ and $5 \cdot (4 \cdot 2) = 40$
c. Distributive property $11(-4 + 3) = -11$ and $11(-4) + 33 = -11$

3.6 Exercises

Concept Check

Fill-in-the-Blank. Complete each sentence using information found in this section.

- The multiplicative inverse of a number is its _____.
- The _____ of all numbers is 1.
- Zero multiplied by a number or variable is an example of the _____ - _____ law.
- The distributive property involves two operations, _____ and _____.
- The additive inverse of a number is the _____ of that number.
- In the term $8x$, the 8 is the _____ of the variable.

True/False. Determine whether each statement is true or false. If a statement is false, explain how it can be changed so the statement will be true. (**Note:** There may be more than one acceptable change.)

7. Changing the order of the numbers in an addition problem is allowed because of the associative property of addition.
8. The equation $(8 \cdot 2) \cdot 5 = 8 \cdot (2 \cdot 5)$ is an example of the associative property of multiplication.
9. The additive identity of all numbers is 1.
10. The commutative property works for division and subtraction.

Practice

Complete the expressions using the given property. Do not simplify.

1. $7 + 3 =$ _____ commutative property of addition
2. $(6 \cdot 9) \cdot 3 =$ _____ associative property of multiplication
3. $19 \cdot 4 =$ _____ commutative property of multiplication
4. $18 + 5 =$ _____ commutative property of addition
5. $6(5 + 8) =$ _____ distributive property
6. $16 + (9 + 11) =$ _____ associative property of addition
7. $2 \cdot (3x) =$ _____ associative property of multiplication
8. $3(x + 5) =$ _____ distributive property
9. $3 + (x + 7) =$ _____ associative property of addition
10. $9(x + 5) =$ _____ distributive property
11. $6 \cdot 0 =$ _____ zero-factor law
12. $6 \cdot 1 =$ _____ multiplicative identity
13. $0 + (x + 7) =$ _____ additive identity
14. $0 \cdot (-13) =$ _____ zero-factor law
15. $2(x - 12) =$ _____ distributive property
16. $(-5) + 5 =$ _____ additive inverse
17. $6.3 + (-6.3) =$ _____ additive inverse
18. $3 \cdot \frac{1}{3} =$ _____ multiplicative inverse

State the name of each property being illustrated. See Example 1.

19. $5 + 16 = 16 + 5$

20. $5 \cdot 16 = 16 \cdot 5$

21. $32 \cdot 1 = 32$

22. $32 + 0 = 32$

23. $5 + (3 + 1) = (5 + 3) + 1$

24. $5 + (3 + 1) = (3 + 1) + 5$

25. $13(y + 2) = (y + 2) \cdot 13$

26. $13(y + 2) = 13y + 26$

27. $6(2 \cdot 9) = (2 \cdot 9) \cdot 6$

28. $6(2 \cdot 9) = (6 \cdot 2) \cdot 9$

29. $5 \cdot \frac{1}{5} = 1$

30. $14 \cdot \frac{1}{14} = 1$

31. $7.1 + (-7.1) = 0$

32. $(-9) + 9 = 0$

33. $1 \cdot 14.2 = 14.2$

34. $(5 \cdot 3) \cdot (-7) = 5(3 \cdot (-7))$

35. $5.68 \cdot 0 = 0 \cdot 5.68 = 0$

36. $0 + 5.68 = 5.68$

37. $2 + (x + 6) = (2 + x) + 6$

38. $2(x + 6) = 2x + 12$

First evaluate each expression using the rules for order of operations and then use the distributive property to evaluate the same expression. The value must be the same.

39. $6(3 + 8)$

40. $7(8 - 5)$

41. $10(2 - 9)$

42. $13(5 + 3)$

For each of the following equations, state the property illustrated, and show that the statement is true for the value of $x = 4$, $y = -2$, or $z = 3$ by substituting the corresponding value in the equation and evaluating. See Example 2.

43. $6 \cdot x = x \cdot 6$

44. $19 + z = z + 19$

45. $8 + (5 + y) = (8 + 5) + y$

46. $(2 \cdot 7) \cdot x = 2 \cdot (7x)$

47. $5(x + 18) = 5x + 90$

48. $(2z + 14) + 3 = 2z + (14 + 3)$

49. $(6 \cdot y) \cdot 9 = 6 \cdot (y \cdot 9)$

50. $11 \cdot x = x \cdot 11$

51. $z + (-34) = -34 + z$

52. $3(y + 15) = 3y + 45$

53. $2(3 + x) = 2(x + 3)$

54. $(y + 2)(y - 4) = (y - 4)(y + 2)$

55. $5 + (x - 15) = (x - 15) + 5$

56. $z + (4 + x) = (4 + x) + z$

57. $(3x) \cdot 5 = 3 \cdot (x \cdot 5)$

58. $(x + y) + z = x + (y + z)$

Applications

Solve.

59. Jessica works part-time at a retail store and makes \$11 an hour. During one week, she worked $6\frac{1}{2}$ hours on Monday and $4\frac{1}{4}$ hours on Thursday.
- Determine the amount of money she earned during the week by evaluating the expression $\$11 \cdot (6\frac{1}{2} + 4\frac{1}{4})$.
 - Rewrite this expression to remove the parentheses using one of the properties talked about in this section.
 - What property did you use in part b. to rewrite the expression?
60. Robin went to the grocery store to buy a few items she needed in order to cook dinner. She bought milk for \$3.99, rolls for \$2.25, a package of steaks for \$12.01, and some marinade for \$1.75. Before getting to the checkout line, Robin remembered that she only had \$20 in her purse. Did she have enough money to buy the food items if the store does not charge sales tax on food?
- Write an expression to find the total of Robin's food purchases. Do not simplify.
 - Robin doesn't have a calculator to determine the total cost of her items. She wants to make sure that she has enough money to buy them. Rearrange the expression from part a. so that she could quickly find the total using mental math.
 - What properties did you use in part b. to rewrite the expression?
 - Did Robin have enough money to purchase all of the items?
61. Jordan didn't balance his checking account during the week and ended up overdrawing his account. He had a starting balance of \$85.04 and wrote checks for two bills for the amounts of \$28.79 and \$50.00. He also used his debit card to purchase lunch for \$12.16. In order to avoid an overdraft fee, Jordan must deposit enough money today to bring his balance back to a minimum of zero.
- Write an expression to find the current balance of Jordan's checking account. Do not simplify.
 - Evaluate the expression from part a. to determine the current balance of Jordan's checking account.
 - Write an equation to show Jordan's current checking account balance plus the amount he must deposit today to bring the balance to zero.
 - What property is illustrated in part c.?

Writing & Thinking

62. a. The distributive property illustrated as $a(b+c) = ab+ac$ is said to "distribute multiplication over addition." Explain, in your own words, the meaning of this phrase.
- b. What would an expression that "distributes addition over multiplication" look like? Explain why this would or would not make sense.

3.7 Exercises

Concept Check

Fill-in-the-Blank. Complete each sentence using information found in this section.

1. If no number is written next to a variable, the coefficient is understood to be the number _____.
2. Any constant, variable, or product or quotient of a constant and/or variable is a/an _____.
3. A single number is a/an _____.
4. In a term, the number being multiplied by the variable is the numerical _____ of that term.
5. To combine like terms, add or subtract the _____ and keep the common variable expression.
6. When substituting, _____ must be used around negative numbers.

True/False. Determine whether each statement is true or false. If a statement is false, explain how it can be changed so the statement will be true. (**Note:** There may be more than one acceptable change.)

7. A variable that does not appear to have an exponent has an exponent of 1.
8. In the term $-9x$, nine is being subtracted from x .
9. In the term " $12a$," 12 is the constant.
10. Like terms have the same coefficients.

Practice

Identify the like terms in each list of terms. See Example 1.

1. $-5, 3, 7x, 8, 9x, 3y$
2. $-2x^2, -13x^3, 5x^2, 14x^2, 10x^3$
3. $5xy, -x^2, -6xy, 3x^2y, 5x^2y, 2x^2$
4. $3ab^2, -ab^2, 8ab, 9a^2b, -10a^2b, ab, 12a^2$
5. $24, 8.3, 1.5xyz, -1.4xyz, -6, xyz, 5xy^2z, 2xyz^2$
6. $-35y, 1.62, -y^2, -y, 3y^2, \frac{1}{2}, 75y, 2.5y^2$

Simplify each expression by combining like terms. See Example 2.

7. $8x + 7x$
8. $3y + 8y$
9. $5x + (-2x)$

- | | |
|-------------------------------|--|
| 10. $7x + (-3x)$ | 26. $-5x - 1 + 8 + 9x$ |
| 11. $6y^2 - y^2$ | 27. $2n^2 - 6n + 1 - 4n^2 + 8n - 4$ |
| 12. $16z^2 - 5z^2$ | 28. $3n^2 + 2n - 5 - n^2 + n - 4$ |
| 13. $3x - 5x + 12x$ | 29. $3 - 5x^2 + 4x^2 + 20x + 42 - 17x$ |
| 14. $2a + 14a - 25a$ | 30. $13x + 12x^2 + 15x - 35 - 41 - 2x^2$ |
| 15. $6c - 13c + 5c$ | 31. $3(n+1) + n$ |
| 16. $40x - 30x - 10x$ | 32. $2(n-4) + n + 1$ |
| 17. $4x + 2 + 3x$ | 33. $5(a-b) + 2a - 3b$ |
| 18. $3x - 1 + x$ | 34. $4a - 3b + 2(a + 2b)$ |
| 19. $5x^2 - 3x^2 + 2x$ | 35. $3(2x + y) + 2(x - y)$ |
| 20. $-2x^2 - x^2 - x$ | 36. $4(x + 5y) + 3(2x - 7y)$ |
| 21. $7x^2 - 4x^2 + 20$ | 37. $y - \frac{4y + 5y}{3}$ |
| 22. $14y^3 - 25 + 8y^3$ | 38. $z - \frac{3z + 5z}{4}$ |
| 23. $2x^2 - 2y + 5x^2 + 6x^2$ | 39. $\frac{2x + 3x}{3} + x$ |
| 24. $4a + 2a - 3b - a$ | 40. $\frac{2y + 4y}{5} - 2y$ |

Evaluate the expression for $x = 2$ and $y = -3$. See Example 3.

- | | |
|--------------|--------------|
| 41. $-x^2$ | 44. $(-y)^2$ |
| 42. $-y^2$ | 45. $-x$ |
| 43. $(-x)^2$ | 46. $-y$ |

Simplify each expression and then evaluate the expression for $x = 4$, $y = 3$, $a = -2$, and $b = -1$. See Examples 4 through 7.

- | | |
|-------------------------------------|---|
| 47. $5y + 4 - 2y$ | 54. $1.3(y + 2) - 2.6(8 - y)$ |
| 48. $7b - 17 - b$ | 55. $\frac{3a + 5a}{-2} + 12a$ |
| 49. $3(y - 1) + 2(y + 2)$ | 56. $8a + \frac{5a + 4a}{9}$ |
| 50. $4(y + 3) + 5(y - 2)$ | 57. $\frac{-4b - 2b}{-3} + \frac{2b + 5b}{7}$ |
| 51. $3.1a^2 - 0.9a^2 + 4a - 5.3a^2$ | 58. $\frac{5b + 3b}{4} + \frac{-4b - b}{-5}$ |
| 52. $8.3x^2 - 5.7x^2 + x^2 + 2$ | |
| 53. $2.4(x + 1) + 1.3(x - 1)$ | |

Simplify each expression and then evaluate the expression for $x = -2$ and $y = -1$. See Examples 4 and 7.

$$59. 2x^2 - 3x^2 + 5x - 8 + 1$$

$$60. 5x^2 - 4x + 2 - x^2 + 3$$

$$61. y^2 + 2y^2 + 2y - 3y$$

$$62. y^2 + y^2 - 8y + 2y - 5$$

$$63. y^3 + 3y^3 + 5y - 4y^2 + 1$$

$$64. 7y^3 + 4y^2 + 6 + y^2 - 12$$

$$65. 2(x^2 - 3x - 5) + 3(x^2 + 5x - 4)$$

$$66. 5(y^2 - 4y + 3) - 2(y^2 - 2y + 10)$$

Simplify each expression and then evaluate the expression for $a = -1$, $b = -2$, and $c = 3$. See Example 5.

$$67. a^2 - a + a^2 - a$$

$$68. a^3 - 2a^3 - 3a + a - 7$$

$$69. 5ab - 7a + 4ab + 2b$$

$$70. 2ab + 4b - 3a + ab - b$$

$$71. 14(a + 7) - 15(b + 6) + 2(c - 3)$$

$$72. 12(a - 3) + 8(b - 2) - 3(c + 4)$$

$$73. 20(a + b + c) - 10(a + b + c)$$

$$74. 16(a - b + c) + 16(-a + b - c)$$

Applications

Solve.

75. An apartment management company owns a property with 100 units. The company has determined that the profit made per month from the property can be calculated using the equation $P = -10x^2 + 1500x - 6000$, where x is the number of units rented per month. How much profit does the company make when 80 units are rented?
76. A ball is thrown upward from an initial height of 96 feet with an initial velocity of 16 feet per second. After t seconds, the height of the ball can be described by the expression $-16t^2 + 16t + 96$. What is the height of the ball after 3 seconds?
77. You have a 5-pound dumbbell that you use for wrist curls and a 10-pound dumbbell that you use for bicep curls. Your little brother likes to brag that if he lifts your 5-pound dumbbell two times, he's actually lifting 10 pounds. Using that logic, you could claim that the amount of weight you lift in a day can be modeled by the expression $5x + 10y$, where x is the number of wrist curls you do and y is the number of bicep curls you do. How much could you claim to have lifted on a day you did 15 wrist curls and 30 bicep curls?
78. Dan has 340 yards of fencing available to enclose a rectangular field. The area of the enclosure using this fencing can be modeled by $A = 170x - x^2$, where x is the width of the field. If the field ends up being 70 yards wide, how much will the area be?

79. A moving company starts the week with 72 bundles of small boxes and 50 bundles of medium boxes. During the week, they use 25 bundles of small boxes and 32 bundles of medium boxes. At the end of the week, they buy 125 bundles of medium boxes. The total number of boxes at the end of the week can be modeled by the expression $72s + 50m - 25s - 32m + 125m$, where s represents the number of boxes in a bundle of small boxes and m represents the number of boxes in a bundle of medium boxes.
- Simplify the expression by combining like terms.
 - How many boxes are in stock at the end of the week if there are 40 boxes in a small bundle of boxes and 30 boxes in a medium bundle of boxes?
80. During a sale, all newly released video games are priced the same and all Blu-ray discs are priced the same. During the first day of the sale, Mitchell buys 4 video games and 6 Blu-ray discs. The next day he buys 2 more video games and returns 2 of the Blu-ray discs. The amount of money Mitchell spends can be modeled by $4v + 6d + 2v - 2d$, where v represents the cost of each video game and d represents the cost of each Blu-ray disc.
- Simplify the expression by combining like terms.
 - How much did Mitchell spend if each video game costs \$35 and each Blu-ray disc costs \$19?

Writing & Thinking

81. Define constant and variable. Explain why those particular words are used.
82. Discuss like and unlike terms and give an example of each.
83. The text recommends simplifying an expression (combining like terms) before evaluating. Do you think this is necessary?
Evaluate the expression $4x^2 - 5(x + 2) + 3x + 10 + 2x$ for $x = 3$:
- by substituting and then evaluating.
 - by first simplifying and then evaluating.
- Which method would you recommend? Why?
84. Explain the difference between -13^2 and $(-13)^2$.

and solving equations in algebra are just that—skills. For sure, without these skills, you would not be able to solve word problems. However, they are not sufficient. That is, you need much more in the way of understanding abstract concepts to be able to solve word problems and to solve problems in your daily life. The good news is that with experience and practice all of this can be learned.

Soon you will be given a chance to solve word problems by translating English phrases into algebraic expressions and sentences into equations. The solutions to the equations are the solutions to the corresponding word problems. In this section, to help in understanding the abstract relationship between word problems and algebraic equations, we are going to reverse the process. You are going to be given an equation and asked to “make up” your own related word problem that might use this equation to find a solution. Consider the following example.

4. Make up a word problem which might use the equation $x + 3x = 19$ in its solution

Note

In Example 4, the translations are not unique. In fact, there are many ways to make up a problem for each equation. However, all word problems should result in the same equation. You should be able to show your word problem to your classmates and have them agree that the related equation will give the solution to the problem.

Example 4 Translating Equations into Word Problems

For each equation, make up your own word problem that might use the equation in its solution. Remember that the variable can be translated into something like “a number” or “some number.”

a. $5x + 10 = -10$

b. $3y + 25 = 2(y + 6)$

Solution

- a. Some number is multiplied by 5 and the product is increased by 10. If the result is equal to -10 , what is the number?
 b. If 25 is added to the product of 3 and a number, the result will be equal to twice the sum of the same number and 6. What is the number?

Now work margin exercise 4.

Margin Exercise Answers

1. a. $7x$ b. $5 + n$ c. $4(y+2)$ d. $2x + 3$ e. $9x - 4$ f. $\frac{3}{n}$ 2. a. $12f$ b. $25 + 0.33x$ 3. Answers will vary. a. the product of ten and a number b. four times a number increased by seven c. seven times the difference between a number and five 4. Answers will vary. For example, a number plus three times that number is equal to nineteen. What is the number?

3.8 Exercises

Concept Check

Fill-in-the-Blank. Complete each sentence using information found in this section.

- A phrase is considered _____ if its meaning is not clear or if it has two or more possible interpretations.
- Phrases such as “a number” or “the number” imply the use of a/an _____.
- Key words such as “decreased by” and “minus” indicate the operation of _____.
- The key words “cube of” and “square of” mean _____ are involved.

5. “Twice” and “three times” indicate the operation of _____.
6. “Divide” and “quotient” specify that _____ should be used.

True/False. Determine whether each statement is true or false. If a statement is false, explain how it can be changed so the statement will be true. (**Note:** There may be more than one acceptable change.)

7. The order in which the values are given is particularly important when working with subtraction and division problems.
8. “More than” and “increased by” are key phrases specifying the operation of subtraction.
9. Division is indicated by the phrase “five less than a number.”
10. Key phrases for parentheses can be used to limit ambiguity in English phrases.

Practice

Write the algebraic expressions described by the English phrases. Choose your own variable. See Example 1.

1. six added to a number
2. seven more than a number
3. four less than a number
4. a number decreased by thirteen
5. the quotient of twice a number and ten
6. the difference between a number and three, all divided by seven
7. four subtracted from the product of six and a number
8. eight minus twice a number
9. the sum of four times a number and twice the same number
10. the sum of nine times a number and the same number
11. fifteen decreased by twice a number
12. twenty decreased by the product of four and a number
13. three times a number, less five times the same number
14. seven times a number, decreased by twice the number
15. nine times the sum of a number and two
16. three times the difference between a number and eight
17. thirteen less than the product of four and the sum of a number and one
18. four more than the product of eight and the difference between a number and six
19. eight more than the product of three and the sum of a number and six
20. six less than twice the difference between a number and seven

- | | |
|--|--|
| <p>21. four less than the product of three and the difference between seven and a number</p> <p>22. nine more than twice the sum of seventeen and a number</p> | <p>23. eighteen less than the quotient of a number and two</p> <p>24. seven increased by the quotient of a number and five</p> |
|--|--|

Translate each pair of English phrases into algebraic expressions. Notice the differences between the algebraic expressions and the corresponding English phrases.

- | | |
|---|---|
| <p>25. a. six less than a number</p> <p style="padding-left: 2em;">b. six less a number</p> <p>26. a. twenty less than a number</p> <p style="padding-left: 2em;">b. twenty less a number</p> | <p>27. a. five less than three times a number</p> <p style="padding-left: 2em;">b. five less three times a number</p> <p>28. a. six less than four times a number</p> <p style="padding-left: 2em;">b. six less four times a number</p> |
|---|---|

Write the algebraic expression described by the English phrases using the given variables. See Example 2.

- | | |
|---|---|
| <p>29. the number of hours in d days</p> <p>30. the cost of x graphing calculators if one calculator costs \$115</p> <p>31. the cost of x gallons of gasoline if the cost of one gallon is \$3.15</p> <p>32. the number of seconds in m minutes</p> <p>33. the number of days in y years (Assume 365 days in a year.)</p> <p>34. the cost of x pounds of candy priced at \$4.95 a pound</p> <p>35. the number of days in t weeks and three days</p> <p>36. the number of minutes in h hours and twenty minutes</p> <p>37. the points scored by a football team on t touchdowns and one field goal (a touchdown is 7 points and a field goal is 3 points)</p> | <p>38. the amount of vacation days an employee has after w weeks if she gets 0.2 vacation days for every week she works</p> <p>39. the cost of renting a car for one day and driving m miles if the rate is \$20 per day plus 15 cents per mile</p> <p>40. the cost of purchasing a fishing rod and reel if the rod costs x dollars and the reel costs \$8 more than twice the cost of the rod</p> <p>41. the perimeter of a rectangle if the width is w centimeters and the length is three centimeters less than twice the width</p> <p>42. the area of a square with side length of c centimeters</p> |
|---|---|

Translate each algebraic expression into an equivalent English phrase. (There may be more than one correct translation.) See Examples 3 and 4.

- | | |
|---|---|
| <p>43. $4x$</p> <p>44. $-9x$</p> <p>45. $x + 5$</p> <p>46. $x - 12$</p> | <p>47. $4x - 7$</p> <p>48. $3x + 5$</p> <p>49. $7(x + 1)$</p> <p>50. $3(x + 2)$</p> |
|---|---|

51. $-2(x-8)$

52. $10(x+4)$

53. $5(2x+3)$

54. $3(4x-5)$

55. $\frac{6}{x-1}$

56. $\frac{9}{x+3}$

57. $6x+x-1$

58. $5x-x+2$

59. $8+2(x-1)$

60. $5-3(x+1)$

Translate each pair of expressions into equivalent English phrases. (There may be more than one correct translation.) Notice the differences between the algebraic expressions and the corresponding English phrases.

61. $3x+7$; $3(x+7)$

63. $7x-3$; $7(x-3)$

62. $4x-1$; $4(x-1)$

64. $5(x+6)$; $5x+6$

Writing & Thinking

65. Explain why translating addition and multiplication problems from English into algebra may be easier than changing subtraction or division problems from English into algebra. (Consider the properties previously studied.)
66. Explain the difference between $5(n+3)$ and $5n+3$ when converting from algebra to English.
67. Make up your own word problem that might use the given equation in its solution. Be creative! Translate the variable into something like “a strange number,” or “the age of a dog,” or “an amount invested.”
- | | |
|-----------------|------------------|
| a. $2x+3=-4$ | d. $n+(n+2)=135$ |
| b. $3x-2=-5$ | e. $2x+3x=x$ |
| c. $n+(n+1)=25$ | f. $x=5x-6x$ |

Example 12 Application: Solving Linear Equations

The original price of a Blu-Ray player was reduced by \$45.50. The sale price was \$165.90. Solve the equation $y - 45.50 = 165.90$ to determine the original price of the Blu-Ray player.

Solution

$$y - 45.50 = 165.90$$

$$y - 45.50 + 45.50 = 165.90 + 45.50$$

Use the addition principle of equality by adding 45.50 to both sides.

$$y = 211.40$$

Simplify.

The original price of the Blu-Ray player was \$211.40.

12. The original price of a wool coat was reduced by \$15.80. The reduced price was \$84.79. Solve the equation $y - 15.80 = 84.79$ to determine the original price of the coat.

Now work margin exercise 12.**Completion Example Answers**

7. $5x - 4x - 1.5 = 6.3 + 4.0$

Write the equation.

$$x - 1.5 = 10.3$$

Combine like terms on both sides of the equation.

$$x - 1.5 + 1.5 = 10.3 + 1.5$$

Add 1.5 (the opposite of -1.5) to both sides of the equation.

$$x = 11.8$$

Simplify.

11. $\frac{4x}{5} = \frac{3}{10}$

Write the equation.

$$\frac{5}{4} \cdot \frac{4}{5} x = \frac{5}{4} \cdot \frac{3}{10}$$

Multiply both sides by $\frac{5}{4}$.

$$1 \cdot x = \frac{1 \cdot \cancel{5}}{4} \cdot \frac{3}{2 \cdot \cancel{5}}$$

Simplify.

$$x = \frac{3}{8}$$

Margin Exercise Answers

1. a. $x = 4$ is not a solution b. $y = 0.5$ is a solution c. $z = 2.2$ is a solution d. $y = -7$ is a solution

2. $x = 17$ 3. $x = -12$ 4. $x = 3.7$ 5. $x = \frac{9}{8}$ 6. $z = -5$ 7. $z = 4.2$ 8. $x = 11$ 9. $x = 4$ 10. $x = 15$

11. $x = \frac{6}{5}$ 12. The original price of the wool coat was \$100.59.

4.1 Exercises

Concept Check

Fill-in-the-Blank. Complete each sentence using information found in this section.

1. A/An _____ is a statement that two algebraic expressions are equal.
2. If an equation contains a variable, any number that gives a true statement when substituted for the variable is a/an _____ of the equation.
3. The _____ principle of _____ involves adding the same algebraic expression to both sides of an equation.

4. The objective of solving linear equations is to get the variable (with a coefficient of +1) on one side of the equation and any _____ on the other side.
5. Multiplying by the reciprocal of the coefficient of the variable is the same as _____ by the coefficient.
6. If both sides of an equation are multiplied by the same nonzero constant, the _____ principle of equality can be used.

True/False. Determine whether each statement is true or false. If a statement is false, explain how it can be changed so the statement will be true. (**Note:** There may be more than one acceptable change.)

7. When an algebraic expression is added to both sides of an equation, the new equation has the same solutions as the original equation.
8. The process of finding the solution set to an equation is called simplifying the equation.
9. A linear equation in x is also called a first-degree equation in x .
10. Equations with the same solutions are said to be equivalent equations.

Practice

Determine whether the given number is a solution to the given equation by substituting and then evaluating. See Example 1.

- | | |
|--|--|
| 1. $x + 4 = 2$ given that $x = -2$ | 6. $-9 - x = -14$ given that $x = 5$ |
| 2. $z + (-12) = 6$ given that $z = 18$ | 7. $-26 + x = -8$ given that $x = -18$ |
| 3. $x - 3 = -7$ given that $x = 4$ | 8. $42 + z = -30$ given that $z = -72$ |
| 4. $x - 2 = -3$ given that $x = 1$ | 9. $ x - -3 = 25$ given that $x = -28$ |
| 5. $-10 + x = -14$ given that $x = -4$ | 10. $ -2 + x = 13$ given that $x = -11$ |

Solve each equation. See Examples 2 through 11.

- | | |
|--------------------|--------------------------------------|
| 11. $x - 6 = 1$ | 20. $18 = z + 1$ |
| 12. $x - 10 = 9$ | 21. $x - 20 = -15$ |
| 13. $y + 7 = 3$ | 22. $x - 10 = -11$ |
| 14. $y + 12 = 5$ | 23. $y + 3.4 = -2.5$ |
| 15. $x + 15 = -4$ | 24. $y + 1.6 = -3.7$ |
| 16. $x + 17 = -10$ | 25. $x + 3.6 = 2.4$ |
| 17. $22 = n - 15$ | 26. $x + 2.7 = 3.8$ |
| 18. $36 = n - 20$ | 27. $x + \frac{1}{20} = \frac{3}{5}$ |
| 19. $6 = z + 12$ | 28. $n - \frac{2}{7} = \frac{3}{14}$ |

29. $5x = 45$

30. $9x = 108$

31. $32 = 4y$

32. $51 = 17y$

33. $\frac{3x}{4} = 15$

34. $\frac{5x}{7} = 65$

35. $\frac{y}{5} = 2$

36. $\frac{x}{3} = -4$

37. $-1 = \frac{x}{8}$

38. $0 = \frac{x}{15}$

39. $7x - 8x = 13 - 25$

40. $10n - 11n = 20 - 14$

41. $3n - 2n + 6 = 14$

42. $7n - 6n + 13 = 22$

43. $1.7y + 1.3y = 6.3$

44. $2.5y + 7.5y = 4.2$

45. $\frac{3}{4}x = \frac{5}{3}$

46. $\frac{5}{6}x = \frac{5}{3}$

47. $7.5x = -99.75$

48. $-14 = 0.7x$

49. $1.5y - 0.5y + 6.7 = -5.3$

50. $2.6y - 1.6y - 5.1 = -2.9$

51. $10x - 9x - \frac{1}{2} = -\frac{9}{10}$

52. $6x - 5x + \frac{3}{4} = -\frac{1}{12}$

53. $1.4x - 0.4x + 2.7 = -1.3$

54. $3.5y - 2.5y - 6.3 = -1.0 - 2.5$

55. $\frac{7x}{4} - \frac{3x}{4} + \frac{7}{8} = \frac{3}{2}$

56. $\frac{5n}{2} - \frac{3n}{2} + \frac{4}{5} = \frac{7}{5} - \frac{1}{10}$

57. $6.2 = -3.5 + 7n - 6n$

58. $-7.2 = 1.3n - 0.3n - 1.0$

59. $1.7x = -5.1 - 1.7$

60. $3.2x = 2.8 - 9.2$

 Use a calculator to help solve the following equations.

61. $y + 32.861 = -17.892$

65. $2.637x = 648.702$

62. $x - 41.625 = 59.354$

66. $-0.3057y = 316.7052$

63. $17.61x - 16.61x + 27.059 = 9.845$

67. $-x = 145.6 + 17.89 - 10.32$

64. $14.83y - 8.65 - 13.83y = 17.437 + 1.0$

68. $-y = 143.5 + 178.462 - 200$

Applications

Solve.

69. The Japanese writing system consists of three sets of characters, two with 81 characters (which all Japanese students must know), and a third, *kanji*, with over 50,000 characters (of which only some are used in everyday writing). If a Japanese student knows 2107 total characters, solve the equation $x + 2(81) = 2107$ to determine the number of *kanji* characters the student knows.

70. A nurse must give a patient 800 milliliters of intravenous solution over 4 hours. This can be represented by the equation $4x = 800$, where x represents the amount of solution the patient receives per hour in milliliters.
- Why was multiplication chosen in the equation?
 - Solve the equation to determine the value of x .
 - What does the answer to part b. mean? Write a complete sentence.
71. John is making a garden in his backyard. He buys enough topsoil to cover 300 square feet. John wants the garden to go along the side of his garage, which is 24 feet in length. To determine how wide the garden needs to be, John uses the equation $24x = 300$, where x is the width of the garden in feet.
- Why was multiplication chosen in this equation?
 - Solve the equation to determine the value of x .
 - What does the answer to part b. mean? Write a complete sentence.
72. A university enrolls both undergraduate and graduate students in all programs of study. There are a total of 28,000 students enrolled. Of this total, 17,500 students are undergraduates. Solve the equation $17,500 + x = 28,000$ to determine how many graduate students are enrolled in the university.
73.  The diameter of the Milky Way is approximately 23,585 times the distance from the sun to the nearest star, Proxima Centauri. Considering that the Milky Way is roughly 100,000 light years across, solve the equation, $23,585x = 100,000$ to find the number of light years from the sun to this star. (Round your answer to the nearest hundredth.)
74. A group of students at Homestate University decide to start a math club. They create a Facebook page for their club, and their goal is get 5000 “likes” for their page. Three months after they launch their club and Facebook page, they have received a total of 3500 likes. Solve the equation $3500 + x = 5000$ to determine how many more likes they need to get to reach their goal.
75. An author is determined to have his first novel published by the publisher of George Orwell’s *1984*, his favorite book. However, his contract with the publisher requires his novel to be at least 75,000 words, and he has only written 63,500 words. Solve the equation, $63,500 + x = 75,000$ to determine how many more words he must write.
76. The best pizza parlor in town slices their large pizzas so that each pizza contains 8 slices. Joe’s fraternity hosts a pizza party for its members and guests, and the fraternity orders large pizzas from the best pizza parlor in town. By the end of the party, 400 slices of pizza had been eaten and all of the pizza boxes were empty. Solve the equation $8x = 400$ to determine how many pizzas were ordered for the party.
77. During rush week at Homestate University, the fraternities and sororities pledge a combined total of 450 freshmen. These 450 freshmen represent $\frac{1}{5}$ of the school’s total enrollment. Solve the equation $\frac{1}{5}x = 450$ to determine the total number of students enrolled at Homestate University.

78. The inventory manager's computer crashed and he did not have a backup of his data. The company manager is requesting an inventory report for the week for a specific item. The inventory manager knows that there are currently 1472 of that item in stock. During the week, a shipment arrived with 1500 of the item. The company also shipped out 975 of the item during the week. This situation can be represented by $x + 1500 - 975 = 1472$, where x is the number of items in the inventory at the beginning of the week.
- Why were the operations of addition and subtraction chosen in this equation?
 - Solve the equation to determine the value of x .
 - What does the answer to part b. mean? Write a complete sentence.
79. Clara has \$4200 saved to use as a down payment on the new car she is buying that costs \$15,750. She will have to get a loan to pay for the rest of the cost. This situation can be modeled by $4200 + x = 15,750$, where x is the amount of the loan in dollars.
- Why was the operation of addition chosen in this equation?
 - Solve the equation to determine the value of x .
 - What does the answer to part b. mean? Write a complete sentence.
80. A sculptor has decided to begin a project to make scale models of famous landmarks out of stone. His first model will be of one of the moai, giant human figures carved from stone on Easter Island. If his model is to be $\frac{1}{12}$ scale, and the original moai weighs 75 tons, solve the equation $12x = 75$ to determine how many tons his completed sculpture will weigh.

Writing & Thinking

81. a. Is the expression $6 + 3 = 9$ an equation? Explain.
- b. Is 4 a solution to the equation $5 + x = 10$? Explain.

4.2 Exercises

Concept Check

Fill-in-the-Blank. Complete each sentence using information found in this section.

1. The first step in solving linear equations that simplify to the form $ax + b = c$ is to combine _____ terms on both sides of the equation.
2. When solving a linear equation that has been simplified to the form $ax + b = c$, use the _____ principle of equality and add the _____ of the constant b to both sides of the equation.
3. Once you have a variable term on one side of the equation and a constant term on the other, use the _____ principle of equality and multiply both sides of the equation by the reciprocal of the coefficient of the variable.
4. When you multiply both sides of the equation by the reciprocal of the coefficient of the variable, the coefficient of the variable will become _____.
5. Check your answer by _____ it in for the variable in the original equation.

True/False. Determine whether each statement is true or false. If a statement is false, explain how it can be changed so the statement will be true. (**Note:** There may be more than one acceptable change.)

6. If an equation of the form $ax + b = c$ uses decimal or fractional coefficients, the addition and multiplication principles of equality cannot be used.
7. The first step in solving $2x + 3 = 9$ is to add 3 to both sides.
8. To solve an equation that has been simplified to $4x = 12$, you need to multiply both sides by $\frac{1}{4}$, or divide both sides by 4.
9. When solving a linear equation with decimal coefficients, one approach is to multiply both sides in such a way to give integer coefficients before solving.

Practice

Solve each equation. See Examples 1 through 7.

- | | |
|-------------------|------------------------|
| 1. $3x + 11 = 2$ | 9. $1 - 3y = 4$ |
| 2. $3x + 10 = -5$ | 10. $5 - 2x = 9$ |
| 3. $5x - 4 = 6$ | 11. $14 + 9t = 5$ |
| 4. $4y - 8 = -12$ | 12. $5 + 2x = -7$ |
| 5. $6x + 10 = 22$ | 13. $-5x + 2.9 = 3.5$ |
| 6. $3n + 7 = 19$ | 14. $3x + 2.7 = -2.7$ |
| 7. $9x - 5 = 13$ | 15. $10 + 3x - 4 = 18$ |
| 8. $2x - 4 = 12$ | 16. $5 + 5x - 6 = 9$ |

17. $15 = 7x + 7 + 8$
18. $14 = 9x + 5 + 8$
19. $5y - 3y + 2 = 2$
20. $6y + 8y - 7 = -7$
21. $x - 4x + 25 = 31$
22. $3y + 9y - 13 = 11$
23. $-20 = 7y - 3y + 4$
24. $-20 = 5y + y + 16$
25. $4n - 10n + 35 = 1 - 2$
26. $-5n - 3n + 2 = 34$
27. $3n - 15 - n = 1$
28. $2n + 12 + n = 0$
29. $5.4x - 0.2x = 0$
30. $0 = 5.1x + 0.3x$
31. $\frac{1}{2}x + 7 = \frac{7}{2}$
32. $\frac{3}{5}x + 4 = \frac{9}{5}$
33. $\frac{1}{2} - \frac{8}{3}x = \frac{5}{6}$
34. $\frac{2}{5} - \frac{1}{2}x = \frac{7}{4}$
35. $\frac{3}{2} = \frac{1}{3}x + \frac{11}{3}$
36. $\frac{11}{8} = \frac{1}{5}x + \frac{4}{5}$
37. $\frac{7}{2} - 5 - \frac{5}{2}x = 9$
38. $\frac{8}{3} + 2 - \frac{7}{3}x = 6$
39. $\frac{5}{8}x - \frac{1}{4}x + \frac{1}{2} = \frac{3}{10}$
40. $\frac{1}{2}x + \frac{3}{4}x - \frac{5}{3} = \frac{5}{6}$
41. $\frac{y}{2} + \frac{1}{5} = 3$
42. $\frac{y}{3} - \frac{2}{3} = 7$
43. $\frac{7}{8} = \frac{3}{4}x - \frac{5}{8}$
44. $\frac{1}{10} = \frac{4}{5}x + \frac{3}{10}$
45. $\frac{y}{7} + \frac{y}{28} + \frac{1}{2} = \frac{3}{4}$
46. $\frac{5y}{6} - \frac{7y}{8} - \frac{1}{12} = \frac{1}{3}$
47. $x + 1.2x + 6.9 = -3.0$
48. $3x - 0.75x - 1.72 = 3.23$
49. $10 = x - 0.5x + 32$
50. $33 = y + 3 - 0.4y$
51. $2.5x + 0.5x - 3.5 = 2.5$
52. $4.7 - 0.5x - 0.3x = -0.1$
53. $6.4 + 1.2x + 0.3x = 0.4$
54. $5.2 - 1.3x - 1.5x = -0.4$
55. $-12.13 = 2.42y + 0.6y - 13.64$
56. $-7.01 = 1.75x + 3.05x - 8.45$
57. $-0.4x + x + 17.2 = 18.1$
58. $y - 0.75y + 13.76 = 14.66$
59. $0 = 17.3x - 15.02x - 0.456$
60. $0 = 20.5x - 16.35x + 0.1245$

 Use a calculator to help solve the following equations.

61. $0.15x + 5.23x - 17.815 = 15.003$
62. $15.97y - 12.34y + 16.95 = 8.601$
63. $13.45x - 20x - 17.36 = -24.696$
64. $26.75y - 30y + 23.28 = 4.4625$

Applications

Solve.

65. The tickets for a concert featuring the new hit band, Flying Sailor, sold out in 2.5 hours. If there were 35,000 tickets sold, solve the equation $35,000 - 2.5x = 0$ to find the number of tickets sold per hour.
66. Katie's nutritionist recommends that she follows a diet of 2000 calories per day. Katie eats 4 times a day, eating the same number of calories at each sitting. However, every morning she stops at the local coffee shop and treats herself to a large flavored coffee that contains 240 calories. Solve the equation $4x + 240 = 2000$ to determine how many calories Katie should eat at each sitting.
67. Salim is a student in a course on the modern British novel. He is given an assignment to read a 350 page novel in 7 days. He reads the first 38 pages of the novel on the day he receives his assignment and decides to finish the novel by reading the same amount of pages of each day until the assignment is due. Solve the equation $6x + 38 = 350$ to determine how many pages Salim should read each day.
68. All snacks (candy, popcorn, and soda) cost \$3.50 each at the local movie theater. Admission tickets cost \$7.50 each. After a long week, Carlos treats himself to a night at the movies. His movie night budget is \$25 and he spends all his movie money. Solve the equation $\$3.50x + \$7.50 = \$25.00$ to determine how many snacks Carlos can buy.
69. The Political Science Club at Homestate University is planning to host an election night party for members and guests. The club plans to serve cookies and estimates it will need a total of 1500 cookies in 6 varieties for the party. The club orders 300 chocolate chip cookies and an equal number of cookies in each of the remaining 5 varieties. Solve the equation $5x + 300 = 1500$ to determine how many cookies of each remaining variety will be ordered.
70. All courses in the Homestate University graduate school are worth 3 credits. To earn a master's degree, a student must earn a total of 36 credits. The student's thesis work counts as 6 credits. Solve the equation $3x + 6 = 36$ to determine how many courses a student must take to earn a master's degree.
71. A rectangular-shaped parking lot is to have a perimeter of 450 yards. If the width must be 90 yards because of a building code, solve the equation $2l + 2(90) = 450$ to determine the length of the parking lot.
72. Jeff, who lives in England, is reading a letter from his pen pal in the United States. His pen pal says that the temperature was 97.7 degrees Fahrenheit that day, making it too hot to play soccer outside. Jeff doesn't know how hot this is, because he is used to temperatures in Celsius. Help Jeff solve the equation, $1.8C + 32 = 97.7$ to determine the temperature in degrees Celsius.
73. The tallest man-made structure in the world is the Burj Khalifa in Dubai, which stands at 2717 feet tall. The tallest tree in the world is a redwood tree in California. If 7 of these trees were stacked on top of each other, they would still be 59.1 feet shorter than the Burj Khalifa. Solve the equation, $7x + 59.1 = 2717$ to determine the height of the tree.

- 74.** A bakery sells cake pops individually and in packages of 4. At the beginning of the day, the bakery had 114 cake pops in stock. They sold 34 individual cake pops and several packages of cake pops. At the end of the day, there were 8 cake pops left. This situation can be modeled by the equation $114 - 34 - 4x = 8$, where x is the number of packages of cake pops sold.
- Explain what each term in the equation $114 - 34 - 4x = 8$ represents in the situation.
 - Solve the equation to determine the value of x .
 - What does the answer to part b. mean? Write a complete sentence.
- 75.** The lowest temperature of the night was reported to be 24°F . The weather report mentioned that the temperature has steadily risen 1.5 degrees per hour since the lowest temperature of the day and it is currently 30°F . This situation can be modeled by the equation $24 + 1.5x = 30$, where x is the time in hours since the lowest temperature was recorded.
- Explain what each term in the equation $24 + 1.5x = 30$ represents in the situation.
 - Solve the equation to determine the value of x .
 - What does the answer to part b. mean? Write a complete sentence.
- 76.** While taking inventory, a nurse records that there are $\frac{3}{5}$ of a box of syringes in one closet, two boxes that are $\frac{1}{8}$ full in another closet, and 24 syringes in the supply cart. He calculates the total to be 194 syringes. The staff member who reorders supplies is new and doesn't know how many syringes are in the boxes that the clinic uses, so she sets up the equation $\frac{3}{5}x + 2\left(\frac{1}{8}x\right) + 24 = 194$, where x is the number of syringes in a box.
- Solve the equation to determine the value of x .
 - What does the answer to part a. mean? Write a complete sentence.

Writing & Thinking

- 77.** Find the error(s) made in solving each equation and give the correct solution.

a. $\frac{1}{3}x + 4 = 9$

$$3 \cdot \frac{1}{3}x + 4 = 3 \cdot 9$$

$$x + 4 = 27$$

$$x + 4 - 4 = 27 - 4$$

$$x = 23$$

b. $5x + 3 = 11$

$$(5x - 3) + (3 - 3) = 11 - 3$$

$$2x + 0 = 8$$

$$\frac{2x}{2} = \frac{8}{2}$$

$$x = 4$$

10. Determine whether the equation $5x + 9 = -13 + 3x$ is a conditional equation, an identity, or a contradiction.

Example 10 Determining Types of Equations

Determine whether the equation $-2(x-7) + x = 14 - x$ is a conditional equation, an identity, or a contradiction.

Solution

$$\begin{array}{ll} -2(x-7) + x = 14 - x & \text{Write the equation.} \\ -2x + 14 + x = 14 - x & \text{Use the distributive property.} \\ 14 - x = 14 - x & \text{Combine like terms.} \\ 14 - x - 14 = 14 - x - 14 & \text{Add } -14 \text{ to both sides.} \\ -x = -x & \text{Simplify.} \\ -x + x = -x + x & \text{Add } x \text{ to both sides.} \\ 0 = 0 & \text{Simplify.} \end{array}$$

The last equation is always true. Therefore, the original equation is an identity, and has an infinite number of solutions. Every real number is a solution.

Now work margin exercise 10.

Completion Example Answers

$$\begin{array}{ll} 7. \quad 4(x+3) = 2(3x-1) + 6 & \text{Write the equation.} \\ 4x + \underline{12} = 6x - \underline{2} + 6 & \text{Use the distributive property.} \\ 4x + 12 = 6x + \underline{4} & \text{Combine like terms.} \\ 4x + 12 - \underline{12} = 6x + 4 - \underline{12} & \text{Subtract } \underline{12} \text{ from both sides.} \\ 4x = 6x - \underline{8} & \text{Simplify.} \\ 4x - \underline{6x} = 6x - 8 - \underline{6x} & \text{Subtract } \underline{6x} \text{ from both sides.} \\ \underline{-2x} = -8 & \text{Simplify.} \\ \underline{-2x} = \underline{-8} & \text{Divide both sides by } \underline{-2}. \\ \underline{-2} \quad \underline{-2} & \\ x = \underline{4} & \text{Simplify.} \end{array}$$

Margin Exercise Answers

1. $x = -6$ 2. $x = -7$ 3. $y = 2$ 4. $x = -5$ 5. $y = -4$ 6. $x = -6$ 7. $x = 2$ 8. contradiction
9. identity 10. conditional

4.3 Exercises

Concept Check

Fill-in-the-Blank. Complete each sentence using information found in this section.

1. A/An _____ is an equation that has an infinite number of solutions.
2. If an equation has a finite number of solutions, it is a/an _____ equation.
3. Every linear equation is a/an _____ equation.

4. If a linear equation simplifies to a statement that is never true, then the original equation is called a/an _____.
5. The solution set of an identity can be written as all _____ numbers or _____.

True/False. Determine whether each statement is true or false. If a statement is false, explain how it can be changed so the statement will be true. (**Note:** There may be more than one acceptable change.)

6. Every linear equation has exactly one solution.
7. If a linear equation simplifies to a statement that is always true, then the original equation is called an identity.
8. If an equation has no solution, it is called an identity.
9. The most general form of a linear equation is $ax + b = cx + d$.

Practice

Solve each equation. See Examples 1 through 7.

- | | |
|------------------------------------|---|
| 1. $3x + 2 = x - 8$ | 20. $x - 0.1x + 0.8 = 0.2x + 0.1$ |
| 2. $5x + 1 = 2x - 5$ | 21. $\frac{2}{3}x + 1 = \frac{1}{3}x - 6$ |
| 3. $4n - 3 = n + 6$ | 22. $\frac{4}{5}n + 2 = \frac{2}{5}n - 4$ |
| 4. $6y + 3 = y - 7$ | 23. $\frac{y}{5} + \frac{3}{4} = \frac{y}{2} + \frac{3}{4}$ |
| 5. $3y + 18 = 7y - 6$ | 24. $\frac{5n}{6} + \frac{1}{9} = \frac{3n}{2} + \frac{1}{9}$ |
| 6. $2y + 5 = 8y + 10$ | 25. $\frac{3}{8}\left(y - \frac{1}{2}\right) = \frac{1}{8}\left(y + \frac{1}{2}\right)$ |
| 7. $3x + 11 = 8x - 4$ | 26. $\frac{1}{2}\left(\frac{x}{2} + 1\right) = \frac{1}{3}\left(\frac{x}{2} - 1\right)$ |
| 8. $9x + 3 = 5x - 9$ | 27. $\frac{2x}{3} + \frac{x}{3} = -\frac{3}{4} + \frac{x}{2}$ |
| 9. $14n = 3n$ | 28. $\frac{3}{4}x + \frac{1}{5}x = \frac{1}{2}x - \frac{3}{10}$ |
| 10. $1.6x = 0.8x$ | 29. $x + \frac{2}{3}x - 2x = \frac{x}{6} - \frac{1}{8}$ |
| 11. $6y - 2.1 = y - 2.1$ | 30. $3x + \frac{1}{2}x - \frac{2}{5}x = \frac{x}{10} + \frac{7}{20}$ |
| 12. $13x + 5 = 2x + 5$ | 31. $3(1 + 9x) = 6(2 - 4x)$ |
| 13. $2(z + 1) = 3z + 3$ | 32. $4(5 - x) = 8(3x + 10)$ |
| 14. $6x - 3 = 3(x + 2)$ | |
| 15. $16y + 23y - 3 = 16y - 2y + 2$ | |
| 16. $5x - 2x + 4 = 3x + x - 1$ | |
| 17. $0.25 + 3x + 6.5 = 0.75x$ | |
| 18. $0.9y + 3 = 0.4y + 1.5$ | |
| 19. $6.5 + 1.2x = 0.5 - 0.3x$ | |

33. $3(4x-1) = 4(2x-3) + 8$
34. $7(2x-1) = 5(x+6) - 13$
35. $5 - 3(2x+1) = 4(x-5) + 6$
36. $-2(y+5) - 4 = 6(y-2) + 2$
37. $8 + 4(2x-3) = 5 - (x+3)$
38. $8(3x+5) - 9 = 9(x-2) + 14$
39. $4.7 - 0.3x = 0.5x - 0.1$
40. $5.8 - 0.1x = 0.2x - 0.2$
41. $0.2(x+3) = 0.1(x-5)$
42. $0.4(x+3) = 0.3(x-6)$
43. $\frac{1}{2}(4-8x) = \frac{1}{3}(4x+7) - 3$
44. $3 + \frac{1}{4}(x-4) = \frac{2}{5}(2+3x)$
45. $0.6x - 22.9 = 1.5x - 18.4$
46. $0.1y + 3.8 = 5.72 - 0.3y$
47. $0.12n + 0.25n - 5.895 = 4.3n$
48. $0.15n + 32n - 21.0005 = 10.5n$
49. $0.7(x+14.1) = 0.3(x+32.9)$
50. $0.8(x-6.21) = 0.2(x-24.84)$

Determine whether each equation is a conditional equation, an identity, or a contradiction. See Examples 8 through 10.

51. $2(3x-1) + 5 = 3$
52. $-2x + 13 = -2(x-7)$
53. $5x + 13 = -2(x-7) + 3$
54. $3x + 9 = -3(x-3) + 6x$
55. $7(x-1) = -3(3-x) + 4x$
56. $3(x-2) + 4x = 6(x-1) + x$
57. $5(x+1) = 3(x+1) + 2(x+1)$
58. $8x - 20 + x = -3(5-2x) + 3(x-4)$
59. $2x + 3x = 5.2(3-x)$
60. $5.2x + 3.4x = 0.2(x-0.42)$

 Use a calculator to help solve each equation.

61. $0.17x - 23.0138 = 1.35x + 36.234$
62. $48.512 - 1.63x = 2.58x + 87.63553$
63. $0.32(x+14.1) = 2.47x + 2.21795$
64. $1.6(9.3+2x) = 0.2(3x+133.94)$

Applications

Solve.

65. Caitlyn and Steve are planning their wedding reception and must decide between two catering halls. The first site, A Wedding Space, rents for \$800 for one day and charges \$50 per person for dinner. The second venue, A Wedding Place, costs \$1000 to rent for one day and charges \$40 per person for the same dinner. Solve the equation $800 + 50x = 1000 + 40x$ to determine how many guests they can invite so that the cost they pay will be the same at both wedding catering halls.
66. The value of a new car depreciates at a rate of about \$250 per month. Suppose a car originally costs \$30,000. The car was bought with a \$1000 down payment and a loan with 0% financing for 60 months with payments of \$200 a month. Solve the equation $30,000 - 250t = 29,000 - 200t$ to determine how many months it will take for the value of the vehicle to equal the amount owed on the loan?

67.  Heidrick has won a chance to “Eat the Elite” at the Zombie Dash 7-mile race. He will receive a 2.25-mile head start. The elite runners run at a pace of 12.6 miles per hour and Heidrick runs at a pace of 6 miles per hour. Solve the equation $12.6t = 6t + 2.25$ to determine how many hours it will take the elite runners catch up to Heidrick? Enter your answer in hours rounded to the nearest hundredth.
68. A company has two packaging options for shipping quantities of a certain inventory item. Option A uses 20 boxes and there are 5 items unpacked. Option B requires more filler and uses 23 boxes, where each box holds 2 fewer items than Option A and there are only 3 items unpacked. This situation can be represented by $20x + 5 = 23(x - 2) + 3$, where x is the number of items that can fit in the box used for Option A.
- What does $20x + 5$ represent in the equation?
 - What does $x - 2$ represent?
 - Solve the equation for x .
 - Check the solution.
 - What does the answer from part c. mean? Write a complete sentence.
69. Two advertisement flyers have the same area. The first flyer has a length of 12 inches and a width of x inches. The second flyer has a length of 4 inches and a width that is 10 inches more than x . This situation can be represented by $12x = 4(10 + x)$, where x is the width of the first flyer.
- What does $12x$ represent in the equation?
 - What does $10 + x$ represent?
 - Solve the equation for x .
 - Check the solution.
 - What does the answer from part c. mean? Write a complete sentence.
70. The manager of a café wants to list a price for the weekly featured combo that includes tax. He wants to sell a medium house-blend coffee with a pastry for a total of \$5.45. He doesn't know which pastry to sell with the coffee to avoid losing money on the combo. The medium coffee costs \$2.75 and the tax is 9%. He uses the equation $1.09(2.75 + x) = 5.45$ to determine the price of the pastry, which is represented by the variable x .
- What does the sum $2.75 + x$ represent?
 - Solve the equation for x .
 - Which of the following pastries would you choose to be a part of the combo? Explain why you made your choice.

cherry pie for \$2.50, coffee cake for \$2.25, bagel for \$2.00
71. A farmer is putting a shed on his property. He has two designs. One uses wood and would cost \$2 per square foot plus an extra \$8400 in materials. The other design is metal and would cost \$4 per square foot plus an additional \$8800. Both sheds are the same size, and the wood shed costs $\frac{3}{4}$ what the metal shed costs. Solve the equation $2x + 8400 = \frac{3}{4}(4x + 8800)$ to determine how many square feet the shed will be.

72. Two rival shoe companies want to rent the same building for their office and shipping space. Schulster's Shoes would use 1000 square feet for offices, 600 for shipping, and another 6 square feet for every packaged box of shoes. Shoes, Shoes, Shoes! would use 750 square feet for offices, 400 for shipping, and 9 square feet per packaged box of shoes. If only one company may occupy the building and the maximum amount of inventory kept by both companies is the same, solve the equation, $1000 + 600 + 6x = 750 + 400 + 9x$ to determine the maximum number of boxes of shoes each company plans to have.
73. An ice cream shop is having a special "Ice Cream Sunday" event in which they are giving away giant mixed sundaes of 3 scoops of vanilla ice cream and 2 scoops of chocolate. If they have 24 gallons of chocolate and 36 gallons of vanilla to start with, solve the equation, $36 - \frac{1}{20}(3x) = 24 - \frac{1}{20}(2x)$ to determine how many sundaes they will have made when they run out of ice cream. (For this problem, we assume a gallon equals 20 scoops.)
74. A guitarist and a drummer are getting ready for a gig. The length of the gig will depend on how much material they have prepared. For every hour of the show, the guitarist must practice for 5 days and the drummer for 3 days. Since the guitarist already knows some of the songs, he saves 3 days of practice time. The drummer hurts his hand and loses 3 days of practice. If they plan to start and finish practicing at the same time, solve the equation, $5x - 3 = 3x + 3$ to determine how long the show will be.

Writing & Thinking

75. Answer each question.
- Simplify the expression $3(x+5) + 2(x-7)$.
 - Solve the equation $3(x+5) + 2(x-7) = 31$.
 - How are the methods you used to answer parts a. and b. similar? How are they different?
76. Write an equation to represent each situation, using x to represent Ryan's current age. Determine whether each equation is a conditional equation, an identity, or a contradiction, and explain why that makes sense for the situation represented.
- In 6 years, Ryan will be 20 years old.
 - In 6 years, Ryan will be 8 years older than he is now.
 - In 6 years, Ryan will be 3 years older than he will be 3 years from now.

9. Given $4x + 8y + 12z = 16$, solve for x .

Completion Example 9 Solving for Different Variables

Given $3x - y = 15$, solve for y in terms of x .

Solution

Supply the reasons for each step in the following solution.

$$\begin{array}{l}
 3x - y = 15 \\
 3x - y - 3x = 15 - 3x \quad \underline{\hspace{2cm}} \\
 -y = 15 - 3x \\
 -1(-y) = -1(15 - 3x) \quad \underline{\hspace{2cm}} \\
 y = -15 + 3x \quad \underline{\hspace{2cm}} \\
 \text{or} \quad y = 3x - 15
 \end{array}$$

Now work margin exercise 9.

Completion Example Answers

$$\begin{array}{l}
 9. \quad 3x - y = 15 \\
 3x - y - 3x = 15 - 3x \quad \text{Subtract } 3x \text{ from both sides.} \\
 -y = 15 - 3x \\
 -1(-y) = -1(15 - 3x) \quad \text{Multiply both sides by } -1 \text{ (or divide both sides by } -1\text{).} \\
 y = -15 + 3x \quad \text{Simplify using the distributive property.} \\
 \text{or} \quad y = 3x - 15
 \end{array}$$

Margin Exercise Answers

1. \$2020 2. $F = 122^\circ\text{F}$ 3. 1,012,500 lb 4. 30° 5. $I = \frac{P}{V}$ 6. $t = \frac{I}{Pr}$ 7. $x = \frac{5}{2}y - 3$
 8. a. $y = \frac{400 - 25z}{16}$ or $y = -\frac{25}{16}z + 25$ b. $z = \frac{400 - 16y}{25}$ or $z = -\frac{16}{25}y + 16$ 9. $x = 4 - 2y - 3z$

4.4 Exercises

Concept Check

Fill-in-the-Blank. Complete each sentence using information found in this section.

- Formulas are general rules or principles stated _____.
- The _____ earned by investing money is equal to the product of the principle times the rate of interest times the time in one year or part of a year.
- The distance traveled equals the product of the rate of speed and the _____.
- The _____ of a rectangle is equal to twice the length plus twice the width.
- If you know values for all but one variable in a formula, you can _____ those values and find the value of the unknown variable by solving the equation.
- If you want to use a formula in another form, treat the variables just as you would _____ in solving linear equations.

True/False. Determine whether each statement is true or false. If a statement is false, explain how it can be changed so the statement will be true. (**Note:** There may be more than one acceptable change.)

7. When using formulas, typically it does not matter if capital or lower case letters are used: $A = a$, $C = c$, etc.
8. If the perimeter and length are known, $P = 2l + 2w$ can be used to find the width of a rectangle.
9. Rate of interest is stated as an annual rate in percent form.

Applications

Refer to Example 1 for information concerning simple interest and the related formula $I = Prt$. (**Note:** Use 365 days in a year and 12 months in each year.)

Simple Interest

1. You want to borrow \$4000 at 12% for only 146 days. How much interest would you pay?
2. For how many days must you leave \$1000 in a savings account at 5.5% to earn \$11.00 in interest?
3. What principal would you need to invest to earn \$450 in simple interest in 6 months if the interest rate was 9%?
4. After one month, Gustav received \$25 in simple interest on his savings account of \$12,000. What was the interest rate?
5. A savings account of \$3500 is left for 9 months and draws simple interest at a rate of 7%.
 - a. How much interest is earned?
 - b. What is the balance in the account at the end of the 9 months?
6. Tim just deposited \$2562.50 to pay off a 3 month loan of \$2500.
 - a. How much of what he deposited was interest on the loan?
 - b. What rate of interest was he charged?

In the following application problems, read the descriptions carefully and then substitute the values given in the problem for the corresponding variables in the formulas. Evaluate the resulting expression for the unknown variable. See Examples 1 through 4.

Velocity

If an object is shot upward with an initial velocity v_0 in feet per second, the velocity v in feet per second is given by the formula $v = v_0 - 32t$, where t is time in seconds. (v_0 is read “v sub zero.” The $_0$ is called a subscript.)

7. An object projected upward with an initial velocity of 106 feet per second has a velocity of 42 feet per second. How many seconds have passed?
8. Find the initial velocity of an object if the velocity after 4 seconds is 48 feet per second.

Medicine

In nursing, one procedure for determining the dosage for a child is

$$\text{child's dosage} = \frac{\text{age of child in years}}{\text{age of child} + 12} \cdot \text{adult dosage.}$$

9. If the adult dosage of a drug is 20 milliliters, how much should a 3-year-old child receive?
10. If the adult dosage of a drug is 340 milligrams, how much should a 5-year-old child receive?

Investments

The total amount of money in an account with P dollars invested in it is given by the formula $A = P + Prt$, where r is the rate expressed as a decimal and t is time (one year or part of a year).

11. If \$1000 is invested at 6% interest, find the total amount in the account after 6 months.
12. How long will it take an investment of \$600, at an annual rate of 5%, to be worth \$615?

Construction

The number N of rafters in a roof or studs in a wall can be found by the formula $N = \frac{L}{d} + 1$, where L is the length of the roof or wall and d is the center-to-center distance from one rafter or stud to the next. Note that L and d must be in the same units.

13. How many rafters will be needed to build a roof 26 ft long if they are placed 2 ft apart center-to-center?
14. A wall has studs placed 16 in. apart center-to-center. If the wall is 20 ft long, how many studs are in the wall?

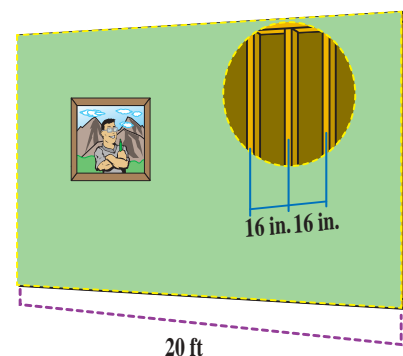
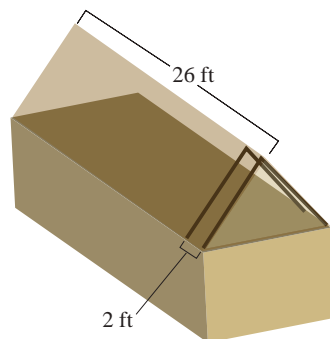

15. How long is a wall if it requires 22 studs placed 16 in. apart center-to-center?
16. What should the center-to-center distance be if you are building a 33 ft long roof using 12 rafters?

Cost

The total cost C of producing x items can be found by the formula $C = ax + k$, where a is the cost per item and k is the fixed costs (rent, utilities, and so on).

17. Find the total cost of producing 30 items if each costs \$15 and the fixed costs are \$580.
18. The total cost to produce 80 dolls is \$1097.50. If each doll costs \$9.50 to produce, find the fixed costs.
19. It costs a company \$3.60 to produce a calculator. Last week the total costs were \$1308. If the fixed costs are \$480 weekly, how many calculators were produced last week?
20. Each week a carpentry shop builds 60 end tables for a total cost of \$5340. If the fixed costs for a week are \$750, what is the cost to produce each end table?

Profit

The profit P is given by the formula $P = R - C$, where R is the revenue and C is the cost.

21. Find the revenue (income) of a company that shows a profit of \$3.2 million and costs of \$1.8 million.
22. Find the revenue of a company that shows a profit of \$3.2 million and costs of \$5.7 million.

Depreciation

Many items decrease in value as time passes. This decrease in value is called depreciation. One type of depreciation is called linear depreciation. The value V of an item after t years is given by $V = C - Crt$, where C is the original cost and r is the rate of depreciation expressed as a decimal.

23. If you buy a car for \$6000 and it depreciates linearly at a rate of 10% per year, what will be its value after 6 years?
24. A contractor buys a 4-year-old piece of heavy equipment valued at \$20,000. If the original cost of this equipment was \$25,000, find the rate of depreciation.

Distance, Rate, Time

The distance traveled d is given by the formula $d = rt$, where r is the rate of speed and t is the time it takes.

25. How long will a truck driver take to travel 350 miles if he averages 50 mph?
26. What is the average rate of speed of a biker who bikes 21.92 miles in 68.5 minutes?
27. What is Jonathan's average rate of speed if he hikes 10.4 miles in 6.4 hours?
28. How long will it take a train traveling at 40 mph to go 140 miles?

Solve each formula for the indicated variable. See Examples 5 through 9.

-
- | | |
|---|--|
| 29. $P = a + b + c$; solve for b . | 48. $v = -gt + v_0$; solve for t . |
| 30. $P = 3s$; solve for s . | 49. $A = \frac{1}{2}bh$; solve for b . |
| 31. $F = ma$; solve for m . | 50. $R = \frac{E}{I}$; solve for I . |
| 32. $C = \pi d$; solve for d . | 51. $V = \pi r^2 h$; solve for h . |
| 33. $A = lw$; solve for w . | 52. $A = \frac{R}{2L}$; solve for L . |
| 34. $P = R - C$; solve for C . | 53. $K = \frac{mv^2}{2g}$; solve for g . |
| 35. $R = np$; solve for n . | 54. $x + 4y = 4$; solve for y . |
| 36. $v = k + gt$; solve for k . | 55. $2x + 3y = 6$; solve for y . |
| 37. $I = A - P$; solve for P . | 56. $3x - y = 14$; solve for y . |
| 38. $L = 2\pi rh$; solve for h . | 57. $5x + 2y = 11$; solve for x . |
| 39. $A = \frac{m+n}{2}$; solve for m . | 58. $-2x + 2y = 5$; solve for x . |
| 40. $P = a + 2b$; solve for a . | 59. $A = \frac{1}{2}h(b+c)$; solve for b . |
| 41. $I = Prt$; solve for t . | 60. $A = P(1+rt)$; solve for r . |
| 42. $R = \frac{E}{I}$; solve for E . | 61. $R = \frac{3(x-12)}{8}$; solve for x . |
| 43. $P = a + 2b$; solve for b . | 62. $-2x - 5 = -3(x+y)$; solve for x . |
| 44. $c^2 = a^2 + b^2$; solve for b^2 . | 63. $3y - 2 = x + 4y + 10$; solve for y . |
| 45. $\alpha + \beta + \gamma = 180^\circ$; solve for β . | 64. $V = \frac{1}{3}\pi r^2 h$; solve for h . |
| 46. $y = mx + b$; solve for x . | |
| 47. $V = lwh$; solve for h . | |

Determine a formula for each of the following situations.

-
65. Each ticket for a concert costs $\$t$ per person and parking costs $\$9.00$. What is the total cost per car C if there are n people in a car?
66. A-to-Z Truck Rentals charges $\$25$ per day plus $\$0.75$ per mile for a 10-foot rental truck. What would you pay per day for renting the truck from A-to-Z if you were to drive the truck x miles in one day?
67. Top-of-the-Line computer company knows that the cost (labor and materials) of producing a computer is $\$325$ per computer per week and the fixed overhead costs (lighting, rent, etc.) are $\$5400$ per week. What are the company's weekly costs of producing n computers per week?
68. If the Top-of-the-Line computer company (see Exercise 67) sells its computers for $\$683$ each, what is its profit per week if it sells the same number n that it produces? (Remember that profit is equal to revenue minus costs, or $P = R - C$.)

Solve.

- 69.** Samantha uses a credit promotion at a home improvement store where she doesn't have to pay any interest on her purchase as long as she pays off the entire balance within 6 months. She purchases \$8000 in merchandise. If she fails to pay off the balance within 6 months, then she will be charged \$600 in interest. Samantha lost the paper work and wants to determine the interest rate on her purchase.
- Which formula from Table 1 fits this situation?
 - Match the variables in the formula from part a. to the information provided.
 - The formula from part a. needs to be solved for which variable?
 - What is the interest rate on her purchase? (Remember to convert to a percent.)
- 70.** In a physics lab, a ball is rolled down an incline that has a machine at the bottom that calculates the force of impact. The ball has a mass of 1.5 kilograms. After several trials, the average force of impact is calculated to be $12.75 \text{ kg} \cdot \text{m/s}^2$. The researchers need to determine the average acceleration of the ball at the moment it struck the machine.
- Which formula from Table 1 fits this situation?
 - Match the variables in the formula from part a. to the information provided.
 - The formula from part a. needs to be solved for which variable?
 - What was the average acceleration of the ball in m/s^2 ?
- 71.** Charles is experimenting with a new sail design for his sailboat and needs to keep the total area of the triangular sail to 150 square feet. The base of the sail must be exactly 3 times the height of the sail.
- What geometric formula for area should be used?
 - Write an expression for the base of the formula using the variable h for height.
 - Substitute the expression from part b. into the area formula for the base.
 - Solve this formula for the height squared.
 - What would you have to do to both sides of the equation in part d. to solve the formula for the height?
 - Substitute 150 for the area of the sail in the formula from part d. and solve for the height of the sail.
 - What is the length of the base of the sail?

Standard Normal (z-scores)

It's often hard to compare values on different scales, but the z-score can help. Suppose Connie scored a 63 on her math exam (where the class average was 60 with a standard deviation of 5) and Mike scored a 78 on his history exam (where the class average was 75 with a standard deviation of 10). Who scored relatively better? By converting both test scores to z-scores, it's easier to compare the values.

$$z_{\text{Connie}} = \frac{63 - 60}{5} = 0.6$$

$$z_{\text{Mike}} = \frac{78 - 75}{10} = 0.3$$

Since Connie's z-score is larger than Mike's, Connie did relatively better on her math exam than Mike did on his history exam.

Writing & Thinking

72. The formula $z = \frac{x - \bar{x}}{s}$ is used extensively in statistics. In this formula, x represents one value in a set of data, \bar{x} represents the average (or mean) of those numbers in the set, and s represents a value called the standard deviation of the numbers. (The standard deviation is a positive number and is a measure of how “spread out” the numbers are.) The values for z are called z-scores, and they measure the number of standard deviation units a number x is from the average \bar{x} .
- a. If $\bar{x} = 70$, what will be the z-score for $x = 70$? Does this z-score depend on the value of s ? Explain.

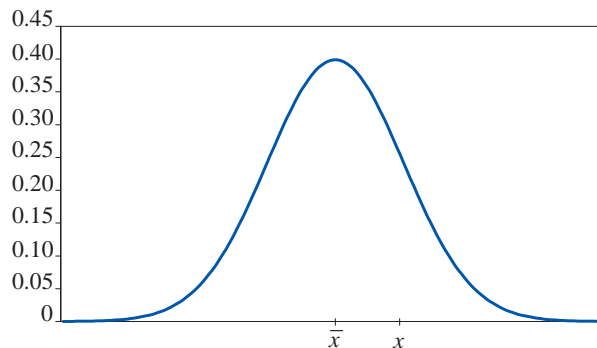

- b. For what values of x will the corresponding z-scores be negative?
- c. Calculate your z-score on each of the last two test scores in this class. (Your instructor will give you the average and standard deviation for each test.) What do these scores tell you about your performance on the two exams?
73. Suppose that, for a particular set of exam scores, $\bar{x} = 72$ and $s = 6$. Find the z-score that corresponds to each of the following scores.
- | | |
|-------|-------|
| a. 78 | c. 81 |
| b. 66 | d. 0 |

4.5 Exercises

Concept Check

Fill-in-the-Blank. Complete each sentence using information found in this section.

1. Integers are _____ if each is 1 more than the previous integer.
2. Three consecutive integers can be represented as n , _____, and _____.
3. Three consecutive even integers can be represented as n , _____, and _____.
4. The whole numbers and their opposites form the set of _____.
5. Even integers are integers that are divisible by ____.
6. Odd integers are integers that are not _____.

True/False. Determine whether each statement is true or false. If a statement is false, explain how it can be changed so the statement will be true. (**Note:** There may be more than one acceptable change.)

7. If an odd integer is divided by 2, the remainder will be 1.
8. To find 3 consecutive odd integers, you could use n , $n + 1$, and $n + 3$.
9. Odd integers are integers that are divisible by 1.
10. Even integers are consecutive if each is 2 more than the previous even integer.

Practice

For each statement, define a variable to represent the unknown quantity. (Be sure that your variable definition includes what quantity is being measured and the units used to measure it.) Then, write an expression, equation, or inequality to represent it.

1. Three-fifths of the savings account balance
2. The radius of the circle increased by 6 centimeters
3. Four times the length of a side of the square is 20 feet.
4. Fifteen percent of your annual salary is 3000 dollars.

Read each problem carefully, translate the various phrases into algebraic expressions, set up an equation, and solve the equation. See Examples 1 through 5.

5. Five less than a number is equal to 13 decreased by the number. Find the number.
6. Three less than twice a number is equal to the number. What is the number?
7. Thirty-six is 4 more than twice a certain number. Find the number.
8. Fifteen decreased by twice a number is 27. Find the number.
9. Seven times a certain number is equal to the sum of twice the number and 35. What is the number?

10. The difference between twice a number and 3 is equal to 6 decreased by the number. Find the number.
11. Fourteen more than 3 times a number is equal to 6 decreased by the number. Find the number.
12. Two added to the quotient of a number and 7 is equal to -3 . What is the number?
13. The quotient of twice a number and 5 is equal to the number increased by 6. What is the number?
14. Three times the sum of a number and 4 is equal to -9 . Find the number.
15. Four times the difference between a number and 5 is equal to the number increased by 4. What is the number?
16. When 17 is added to 6 times a number, the result is equal to 1 plus twice the number. What is the number?
17. If the sum of twice a number and 5 is divided by 11, the result is equal to the difference between 4 and the number. Find the number.
18. If the difference between a number and 21 is divided by 2, the result is 4 times the number. What is the number?
19. Twice a number increased by 3 times the number is equal to 4 times the sum of the number and 3. Find the number.
20. Twice the difference between a number and 10 is equal to 6 times the number plus 16. What is the number?
21. The sum of two consecutive odd integers is 60. What are the integers?
22. The sum of two consecutive even integers is 78. What are the integers?
23. Find three consecutive integers whose sum is 69.
24. Find three consecutive integers whose sum is 93.
25. The sum of four consecutive integers is 74. What are the integers?
26. Find four consecutive integers whose sum is 90.
27. 171 minus the first of three consecutive integers is equal to the sum of the second and third. What are the integers?
28. If the first of three consecutive integers is subtracted from 120, the result is the sum of the second and third. What are the integers?
29. Four consecutive integers are such that if 3 times the first is subtracted from 208, the result is 50 less than the sum of the other three. What are the integers?
30. Find two consecutive integers such that twice the first plus three times the second equals 83.
31. Find three consecutive even integers such that the first plus twice the second is 54 less than four times the third.
32. Find three consecutive odd integers such that 4 times the first is 44 more than the sum of the second and third.
33. Find three consecutive even integers such that if the first is subtracted from the sum of the second and third, the result is 66.
34. Find three consecutive even integers such that their sum is 168 more than the second.
35. Find three consecutive odd integers such that the sum of twice the first and three times the second is 7 more than twice the third.
36. Find three consecutive even integers such that the sum of three times the first and twice the third is twenty less than six times the second.

Applications

Solve.

-
37. An art show charges \$12.50 for admission and sells 4-inch by 6-inch postcards of works by the featured artists for \$2.75 each. Brooke attends the art show and spends a total of \$37.25 on admission and postcards. The situation can be modeled by $\$37.25 = \$12.50 + \$2.75p$.
- The unknown value is represented by the variable p in the equation. What is the unknown value in this situation?
 - Solve the equation for the variable.
 - What does the answer to part b. mean? Write a complete sentence.
38. Robin is in charge of purchasing desserts for a dinner party that her nonprofit organization is throwing. She decides to buy a cake and several specialty cupcakes from Barbara's Bombtastic Bakery. She needs to buy one 8-inch round cake, which costs \$19.50. She has \$45 to spend and will spend the leftover amount on cupcakes, which are \$8.50 for a box of 4. How many boxes of cupcakes can Robin purchase?
- What is the unknown value in this problem? Let the variable c represent this unknown value.
 - Write an equation to represent this situation.
 - Solve the equation for the variable.
 - What does the answer to part c. mean? Write a complete sentence.
39. For his Superbowl party, John bought 3 large pizzas: a pepperoni, a sausage and mushroom, and a Hawaiian pizza with ham and pineapple. Each pizza was cut into the same number of slices. After the party was over, there was $\frac{1}{4}$ of the pepperoni pizza left, $\frac{1}{2}$ of the sausage and mushroom pizza left, and $\frac{3}{8}$ of the Hawaiian pizza left. There were a total of 9 pieces of pizza leftover. How many slices was each pizza cut into?
- What is the unknown value in this problem? Let the variable p represent this unknown value.
 - Write an equation to represent this situation.
 - Solve the equation for the variable.
 - What does the answer to part c. mean? Write a complete sentence.
40. A mathematics student bought a calculator and a textbook for a course in statistics. If the textbook costs \$67.51 more than the calculator, and the total cost for both was \$329.49, what was the cost of each item?
41. The total cost of a computer flash drive and an all-in-one printer was \$96.94, including tax. If the cost of the flash drive was \$58.96 less than the printer, what was the cost of each item?
42. A real estate agent says that the current value of a 25-year old home is \$90,000 more than twice its value when it was new. If the current value is \$310,000, what was the value of the home when it was new?

43. On average, the number of electric guitars sold in Texas each year is 91,399, which is seven times the average number of guitars sold each year in Wyoming. How many electric guitars, on average, are sold each year in Wyoming?
44. A classic car is now selling for \$1500 more than three times its original price. If the selling price is now \$12,000, what was the car's original price?
45. On August 24, the Fernandez family received 19 pieces of mail, consisting of magazines, bills, letters, and ads. If they received the same number of magazines as letters, three more bills than letters, and five more ads than bills, how many magazines did they receive?
46. A pet boarding facility cared for a total of 542 dogs and cats in a given year. If the facility cared for 56 more dogs than cats, how many cats did the facility care for that year?

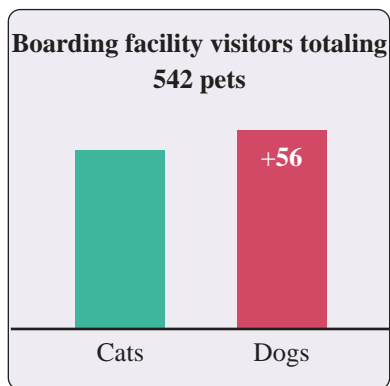

47. Lucinda bought two buckets of golf balls for the driving range. She gave the pro-shop clerk a 50-dollar bill and received \$10.50 in change. What was the cost of one bucket of golf balls? (Tax was included.)



48. A guitar manufacturer spent \$158 million on the production of acoustic and electric guitars last year. If the amount the company spent producing acoustic guitars was \$68 million more than it spent on producing electric guitars, how much did the company spend producing electric guitars?
49. The cost to rent a ballroom at a convention center for one day is \$800 for the first 2 hours. Every additional hour that the ballroom is in use costs an additional \$50 per hour, which is used to cover security fees. If you owe \$1450 for a one-day rental of the ballroom, how many hours did you use the ballroom?
50. The cost to rent a party room at an arcade is a fixed price per hour plus \$15 per child. If a 3-hour room rental with 20 children costs \$330, what is the fixed price per hour for the room rental?
51. A-to-Z Truck Rentals charges \$19.99 per day plus 65¢ per mile driven to rent a pick-up truck. For a one day trip, Louis paid a rental fee of \$127.24. How many miles did he drive?

52. A 29-foot board is cut into three pieces at a sawmill. The second piece is 2 feet longer than the first and the third piece is 4 feet longer than the second. What are the lengths of the three pieces?

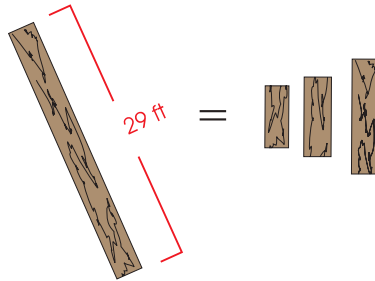

53. The three sides of a triangle are n , $4n - 4$, $2n + 7$ (as shown in the figure). If the perimeter of the triangle is 59 cm, what is the length of each side? (**Reminder:** The perimeter of a triangle is the sum of the lengths of the sides.)

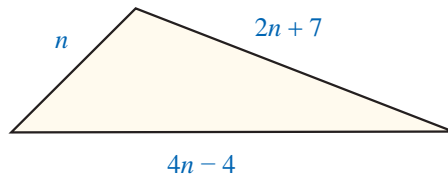

54. Joe Johnson decided to buy a lot and build a house on the lot. He knew that the cost of constructing the house was going to be \$50,000 less than the cost of the lot. He told a friend that the total cost was going to be \$500,000. As a test to see if his friend remembered the algebra they had together in school, he challenged his friend to calculate what he paid for the lot and what he was going to pay for the house. What was the cost of the lot and the cost of the house?

55. The three sides of a triangle are x , $3x - 1$, and $2x + 5$ (as shown in the figure). If the perimeter of the triangle is 64 inches, what is the length of each side?

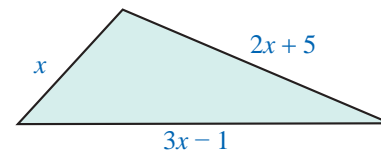

Write a word problem which leads to each equation. Be sure to include a description of the situation and a question which would be answered by solving the equation. Make up your own word problem that might use the given equation in its solution. Be creative! Then solve the equation and check to see that the answer is reasonable.

56. $5x - x = 8$

60. $3(n+1) = n + 53$

57. $2x + 3 = 9$

61. $2(n+2) - 6 = n + 4 - n$

58. $n + (n+1) = 33$

59. $n + (n+4) = 3(n+2)$

Writing & Thinking

62. a. How would you represent four consecutive odd integers?
 b. How would you represent four consecutive even integers?
 c. Are these representations the same? Explain.

Margin Exercise Answers

1. 2 hours 2. First part took $\frac{4}{3}$ or $1\frac{1}{3}$ hours; Second part took $\frac{8}{3}$ or $2\frac{2}{3}$ hours. 3. \$2300 in the low-risk stock; \$12,700 in the high-risk stock. 4. 53 5. 38,000 students 6. \$2300

4.6 Exercises

Concept Check

Fill-in-the-Blank. Complete each sentence using information found in this section.

- To calculate distance, find the product of the _____ and _____.
- In the formula $Pr = I$, I represents _____, P represents _____, and r represents _____.
- In a simple interest problem, if r is 0.12, this represents an interest rate of _____.
- Given cost x , a discount of _____% can be represented as $0.25x$.
- In the formula, $Pr = I$, the time period is _____ year(s).
- When solving distance-rate-time problems, a/an _____ or _____ showing the known and unknown values is helpful.

True/False. Determine whether each statement is true or false. If a statement is false, explain how it can be changed so the statement will be true. (**Note:** There may be more than one acceptable change.)

- When using the formula $I = Pr$, the value of r should be written as a percent.
- In the distance-rate-time formula $d = r \cdot t$, the value t stands for the time spent traveling.
- Profit can be determined by subtracting the cost from the selling price.
- The concept of average can be used to find unknown numbers.

Applications

Solve.

- Dana finds the perfect dress for the Freshman Dance on sale at Belk. If she paid \$95.96 for the dress on sale (before tax) and the dress was marked 20% off, find the original price of the dress.
 - Is the 20% marked off the price she paid, or the original price?
 - How do you represent the original price; the amount of the discount?
 - Set up an equation and solve for the original price of the dress.

2. Tommy inherits \$5000 from his grandmother. He decides to invest some of the money in a CD paying a 4% return and the rest in a money market account (MMA) paying a 3% return. How much did he invest in each if the total amount of return was \$187.50?
 - a. How do you represent the money invested in the CD? The money invested in the MMA?
 - b. How do you represent the total amount of return from the CD; from the MMA?
 - c. Set up an equation by equating the values of the total amount of the return.
 - d. Solve the equation and answer the question.
3. Mary Kate is preparing the Chemistry lab for an experiment that calls for a solution containing 20% ethyl alcohol. However, she only has 10% solution and 25% solution.
 - a. How much alcohol is there in 20 liters of 10% alcohol solution?
 - b. Write an algebraic expression for the amount of alcohol contained in x liters of the 25% solution.
 - c. Write an algebraic expression for the total amount of solution created when x liters of the 25% solution is added to 20 liters of the 10% solution.
 - d. Take 20% of the amount in part c. and set it equal to the total from parts a. and b. to equate the amount of alcohol in the mixed solution to a 20% solution.
 - e. Solve the equation found in part d. to determine how much 25% solution Mary Kate used to make a 20% solution.
4. The local grocery store offers two varieties of salami at the deli counter. The price per pound of the second, more expensive, salami is \$3 more than twice the price per pound of the first variety. If Johannes buys 2 pounds of each type of salami, and his total price is \$29.94, find the price per pound for each variety of salami.
 - a. How do you represent the price of the first variety of salami; the second variety?
 - b. How do you represent the amount spent on the first variety; the second variety?
 - c. Set up an equation and find the price per pound of the first variety.
 - d. What is the price per pound of the second variety? Verify the two prices are correct.
5. Brian has a collection of dimes and quarters in his pocket. He has twice as many dimes as quarters, and the total value of the coins is \$2.70. How many of each type of coin does he have?
 - a. Solve this problem by defining a variable, writing an equation, and solving that equation.
 - b. Explain how you can check your answer without using your equation from part a.

6. Two bicyclists, Chantelle and Taylor, start from opposite ends of a 19-mile-long bike path. Taylor rides her bike 6 mph faster than Chantelle, and the cyclists meet in 30 minutes. How fast was each of them riding? Draw a picture to represent the described problem.
 - a. Use a table to organize the information given in the problem.
 - b. Write an equation based on your diagram and/or table.
 - c. Solve the equation and relate your answer to the original problem.
7. What is Nathan's average rate of speed if he hikes 12.6 miles in 7.5 hours?
8. What is Amy's average rate of speed if she bikes 39.6 miles in 2.2 hours?
9. Jamie plans to take the scenic route from Los Angeles to San Francisco. Her GPS tells her it is a 420-mile trip. If she figures her average speed will be 48 mph, how long will the trip take her?
10. Scott's average speed on his drive from Memphis, TN, is 60 mph. If the total trip is 285 miles, how long should he expect the drive to take?
11. Jane rides her bike to Lake Junaluska. Going to the lake, her average speed is 12 mph. On the return trip, her average speed is 10 mph. If the round trip takes a total of 5.5 hours, how long does the return trip take?
12. Two planes which are 2475 miles apart fly toward each other. Their speeds differ by 75 mph. If they pass each other in 3 hours, what is the speed of each?



13. Marcus drives from Chicago to Detroit in 6 hours. On the return trip, his speed is increased by 10 mph and the trip takes 5 hours. Find his rate on the return trip. How far apart are the towns?
14. Tim and Barb have 8 hours to spend on a mountain hike. They can walk up the trail at an average rate of 2 mph and can walk down at an average rate of 3 mph. How long should they plan to hike uphill before turning around?
15. The Reeds are moving across Texas. Mr. Reed leaves $3\frac{1}{2}$ hours before Mrs. Reed. If his average speed is 40 mph and her average speed is 60 mph, how long will Mrs. Reed have to drive before she overtakes Mr. Reed?
16. After traveling for 40 minutes, Mr. Koole had to slow to $\frac{2}{3}$ his original speed for the rest of the trip due to heavy traffic. The total trip of 84 miles took 2 hours. Find his original speed.
17. A train leaves Cincinnati at 2:00 p.m. A second train leaves the same station in the same direction at 4:00 p.m. The second train travels 24 mph faster than the first. If the second train overtakes the first at 7:00 p.m., what is the speed of each of the two trains?
18. Maria runs through the countryside at a rate of 10 mph. She returns along the same route at 6 mph. If the total trip took 1 hour 36 minutes, how far did she run in total?

19.  The distance from Atlanta, Georgia, to Washington, DC, is 620 miles. Driving in the middle of the night, it takes about 9 hours to get to Washington. Due to higher traffic volume, it takes 2 more hours to travel there during the day. What is the average rate of the driver during the day and during the night? (Round to the nearest whole number.)
20. Mr. Kent drove to a conference. The first half of the trip took 3 hours due to traffic. Traffic let up for the second half of the trip, and he was able to increase his speed by 20 mph to make sure he got there on time. Find his rates of speed if he traveled 2 hours at the second rate.
21. Jayden walked to his friend's house at a rate of 4 mph to borrow his friend's bicycle. Coming back home, he rode the bicycle at an average rate of 12 mph. The total time for the round trip was 1 hour 30 minutes. How far away does Jayden's friend live?
22. Once a week, Felicia walks/runs for a total of 6 miles. Felicia spends twice as much time walking as she does running. If she walks at a rate of 4 mph and runs three times faster than she walks, what is the time for each part?
23. Achilles is racing a tortoise and gives him a 2-hour head start. The tortoise runs at a pace of 10 miles per hour and Achilles runs at a pace of 25 miles per hour. How long will it take Achilles to catch up to the tortoise?

- a. Fill out the $d = r \cdot t$ table. Let the variable t represent the amount of time that the tortoise has traveled.

| Rate (mph) | · | Time (min) | = | Distance (miles) |
|------------|---|------------|---|------------------|
| Tortoise | | | | |
| Achilles | | | | |

- b. When Achilles catches up to the tortoise, they will have traveled the same distance. Set up a linear equation using the information in the table.
- c. Solve the equation from part b. for the variable.
- d. How long will it take Achilles to catch up to the tortoise?
- e. If the race is 35 miles long, will Achilles pass the tortoise before crossing the finish line? Show work to support your answer.
24. Amanda invests \$25,000, part at 5% and the rest at 6%. The annual return on the 5% investment exceeds the annual return on the 6% investment by \$40. How much did she invest at each rate?
25. Mr. Hill invests \$10,000, part at 5.5% and part at 6%. The annual interest from the 5.5% investment exceeds the annual interest from the 6% investment by \$251. How much did he invest at each rate?
26. The annual interest earned on a \$6000 investment was \$120 less than the interest earned on \$10,000 invested at 1% less interest per year. What was the rate of interest on each amount?
27. Two investments totaling \$16,000 produce an annual income of \$1140. One investment yields 6% a year, while the other yields 8% per year. How much is invested at each rate?

- 28. The annual interest on a \$4000 investment exceeds the interest earned on a \$3000 investment by \$80. The \$4000 is invested at a 0.5% higher rate of interest than the \$3000. What is the interest rate of each investment?
- 29. D’Andra makes two investments that total \$12,000. One investment yields 8% per year and the other 10% per year. The total interest for one year is \$1090. Find the amount invested at each rate.
- 30. A company is planning to invest \$42,000 into two simple interest accounts. The annual interest rate on one of the accounts is 4.5% while the rate on the other is 6%. How much should the company invest in each account so that the two accounts will produce an equal annual interest income?
- 31. Savannah invests \$3600 per year into her retirement account, a portion of which is a contribution match from her employer. Savannah invests the employer match in a high-risk fund that averages a return of 8% and invests the rest in a low-risk account that averages a return of 4%. She wants to earn a total of \$198 in interest for the year. How much should be invested in each fund?

- a. Fill out the $I = P \cdot r$ table. Let the variable P represent the amount of money invested in the high-risk fund.

| Principal (\$) | · | Rate | = | Interest (\$) |
|----------------|---|------|---|---------------|
| High-Risk Fund | | | | |
| Low-Risk Fund | | | | |

- b. Write an equation to represent the total interest earned for the year by using the information in the table.
 - c. Solve the equation from part b. for the variable.
 - d. How much should be invested in each fund?
 - e. Verify that investing the amounts from part d. at the given rates yields \$198 total interest in Savannah’s retirement account.
- 32. A particular style of shoe costs a shoe store \$81 per pair. What should the selling price of the shoes be so a 10% discount results in a 25% profit?
 - 33. Sebastian would like both of his investments, a total of \$12,000, to bring him the same annual interest income. One of his investments is at 5.5% annual interest rate and the other at 7%. Find the amount of money that Sebastian should invest in each account.
 - 34. A car dealer paid \$3800 for a used car. For his upcoming Labor Day sale, he wants to offer a 10% discount off the posted selling price, but would still like to make a 35% profit. What price should he advertise for that car?
 - 35. Gabriella got some money from her grandparents as a graduation present. She decided to invest all of it. Part of the money was invested at a 2.5% interest rate, and the rest at a 4% interest rate. She invested \$200 more in the 4% account than the 2.5% account. If her annual interest income was \$47, how much did she invest at each rate?
 - 36. Jordan is earning 1.5% interest from money invested in a savings account and 4% interest on a mutual bond fund. If the total of his investments is \$18,000 and the annual interest from the savings account is less than the annual interest from the bond by \$60, how much has Jordan invested at each rate?

37. A small company invested \$20,500 such that a part of the money is in an account with a 4% interest rate and the rest at a 5% rate. The annual interest from the 5% account is \$35 more than the interest earned from the 4% account. Find the amount of money the company invested at each rate.
38. During the month of January, a department store would like to have a sale of 40% off of women's knee-high boots. The store purchased the boots for \$33 per pair. How much should the selling price be, if the manager of the store wants to make a 10% profit per pair?
39. Carla plans on buying a new pair of sandals for the summer. They are on sale for 20% off of the original price. What was the original price of the sandals, if she pays \$34.83, with 7.5% sales tax?
40. Last year, an individual invested some money at a 5% interest rate and \$2200 less than that amount at a 6% interest rate. If his interest income was \$880, how much did he invest at each rate?
41. A store purchased a certain style of leather jacket at \$70 per jacket. If the store wants to sell the jackets at a 20% discount and still make a profit of 30%, what should be the marked selling price for each jacket?
42. After receiving a 10% off coupon in the mail, Mark decided that it was time to buy new headphones. Using the coupon and paying 8% sales tax, the final price came to \$213.84. What was the listed price of the headphones?
43. Robin's Refurbished Wrecks purchased a used car for \$2850. For the upcoming Labor Day sale, the car dealership would like to offer a 5% discount off the posted selling price of the car, but would still like to make a 40% profit. What price should the car dealership advertise for the car?
- Use the purchase price of the car to determine how much a 40% profit will be.
 - Use the variable x to represent the actual selling price of the car. Write an expression to represent the selling price of the car after the 5% discount.
 - Write an equation that represents the situation by using the answers from parts a. and b. along with the equation $\text{selling price} - \text{cost} = \text{profit}$.
 - Solve the equation from part c.
 - What does the answer from part d. mean? Write a complete sentence.
44. Marissa has five exam scores of 75, 82, 90, 85, and 77 in her chemistry class. What score does she need on the final exam to have an average grade of 80 (and thus earn a grade of B)? (All exams have a maximum of 100 points.)
45. Gerald had scores of 80, 92, 89, and 95 on four exams in his algebra class. What score will he need on his fifth exam to have an overall average grade of 90? (All exams have a maximum of 100 points.)
46. While riding her bike to the park and back home five times, Stacey timed herself at 60 min, 62 min, 55 min (the wind was helping), 58 min, and 63 min. She had set a goal of having an average time of 60 minutes for her rides. How many minutes will she need on her sixth ride to attain her goal?



TV Watching Trend

In recent years, there has been a decline in the watching of network television. With the expansion of alternative programming options such as Netflix and Amazon Prime Video, more people are switching away from the traditional networks. This can also be seen in the nominations (and winners) of the television awards. Lately, the list of award nominees barely includes any of the traditional networks' shows or actors. The graph shows the decline in television viewing among millennials from 2014 through 2018.

Source: www.usatoday.com/story/life/tv/2018/11/12/cord-cutting-and-streaming-younger-viewers-cut-into-traditional-tv-viewing/1924404002/

47. For every 4-week period, Lauren wants to make an average of 6 phone calls per week. The first week she made 9 phone calls; the second week she made 6 phone calls, and the third week 5 phone calls. How many phone calls does Lauren need to make in the fourth week to make sure she stays on track with her goal?
48. While growing up, Jason was allowed to watch TV an average of 3 hours a day over a one-week period. One particular week he watched 1 hour, 2 hours, 1 hour, 3 hours, 3 hours, and 5 hours. How many hours could Jason watch the seventh and last day of the week and still obey his parents?
49. A college student realized that he was spending too much money on video games. For the remaining 5 months of the year, his goal is to spend an average of \$50 a month towards his hobby. How much can he spend in December, taking into consideration that the other 4 months he spent \$70, \$25, \$105, \$30, respectively?
50. Wade has scores of 59, 68, 76, 84, and 69 on the first five tests in his social studies class. He knows that the final exam counts as two tests. What score will he need on the final to have an average of 70? (All tests and exams have a maximum of 100 points.)
51. A statistics student has grades of 86, 91, 95, and 76 on four hour-long exams. What score must he receive on the final exam to have an average grade of 90 if
 - a. the final is equivalent to a single hour-long exam (100 points maximum)?
 - b. the final is equivalent to two hour-long exams (200 points maximum)?
52.  Consider the monthly temperatures over a year for a city in New Zealand.
 - a. Find the average temperature for the year. (Round to the nearest tenth.)
 - b. Find the minimum average monthly temperature for the year.
 - c. Find the difference in average monthly temperature between the months of June and December.

Monthly Temperatures

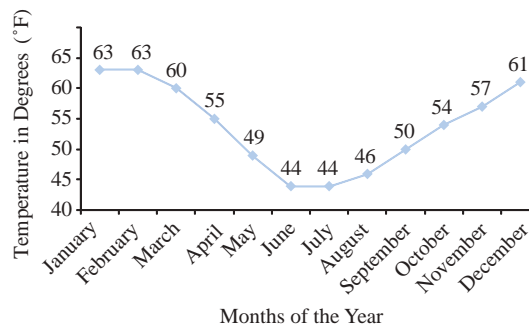

53.  Consider the averages of monthly rainfall over a year for Visakhapatnam, India. ¹
- Find the average rainfall for the year. (Round to the nearest tenth.)
 - Find the maximum average monthly rainfall for the year.
 - Find the difference in average monthly rainfall between the months of October and December.

Average Monthly Rainfall in Visakhapatnam, India

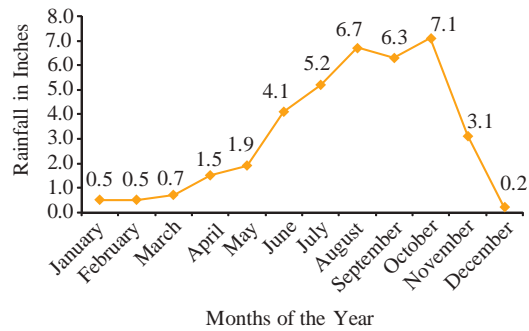

54.  Consider the yearly profits of the world's largest companies in 2020. ²
- Find the average profits of the companies in the year 2020. (Round to the nearest tenth of a billion.)
 - Find the yearly profits of SoftBank Group in the year 2020.
 - What was the difference in profits between ICBC and Berkshire Hathaway?

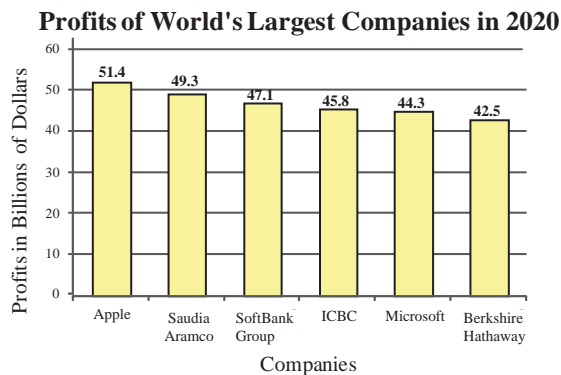

¹ Source: www.weather.com

² Source: "Leading companies in the world in 2020, by net income," Statista, August 2021, www.statista.com/statistics/269857/most-profitable-companies-worldwide/.

55. Consider the number of passengers at the following airports. ³
- Find the average number of passengers.
 - Find the difference in passengers between Atlanta, GA, and Tokyo.
 - What was the total number of passengers to go through London?

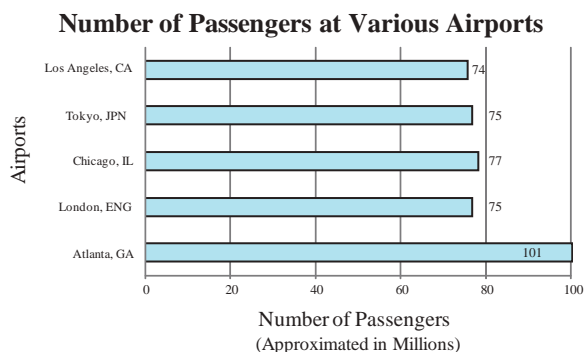

56. Kevin consulted a dietician who told him to consume an average of 2100 calories per day based on his age, current weight, activity level, and weight goals. Kevin kept track of his calorie intake for several days. He consumed 2050 calories on Monday, 2200 calories on Tuesday, 2300 calories on Wednesday, and 2400 calories on Thursday. How many calories would he need to consume on Friday to have an average calorie intake of 2100 for the five days?
- Set up an equation to solve for the amount of calories Kevin would need to consume on Friday. Use the variable x to represent the number of calories needed.
 - Solve the equation from part a. for the variable.
 - Some sources recommend that active men consume more than 1500 calories per day to avoid triggering “starvation mode” in the body. Can Kevin stay above this calorie amount and meet his recommended average for the 5 days?
 - Do you think this is a smart way for Kevin to adjust his average calorie intake? If not, what are some alternatives?

Writing & Thinking

Each of the following problems is given with an incorrect answer. Explain how you can tell that the answer is incorrect without needing to solve the problem or do any algebra; then, solve the problem correctly.

57. The perimeter of an isosceles triangle is 16 cm. Since the triangle is isosceles, two sides have the same length; the third side is 2 cm shorter than one of the two equal sides. Find the length of one of the two equal sides. **Incorrect answer: 9 cm**
58. Leela found a used textbook, which was marked down 50% from the price of the new textbook. If the used textbook cost \$60, how much did the new textbook cost? **Incorrect answer: \$90**
59. Kareem can paddle his kayak at 6 mph in still water. He decides to go kayaking on the local river. He paddles downriver (with the current) for 2 hours; then he turns around and paddles upriver (against the current) for 2.5 hours, returning to his starting point. How fast is the current in the river? **Incorrect answer: 27 mph**

Solution

- a. First find the profit.

$$\begin{array}{r} \$72 \quad \text{Selling price} \\ -\$45 \quad \text{Cost} \\ \hline \$27 \quad \text{Profit} \end{array}$$

The profit is \$27 per calculator.

For parts b. and c., use a ratio and then change the fraction to a percent to find each percent of profit.

- b. For percent of profit based on cost, remember that cost is in the denominator.

$$\frac{\text{Profit}}{\text{Cost}} = \frac{\$27}{\$45} = \frac{3}{5} = 60\%$$

The percent of profit based on cost is 60%.

- c. For percent of profit based on selling price, remember that selling price is in the denominator.

$$\frac{\text{Profit}}{\text{Selling Price}} = \frac{\$27}{\$72} = \frac{3}{8} = 37.5\%$$

The percent of profit based on selling price is 37.5%.

Note

Percent of profit **based on cost** is normally higher than percent of profit **based on selling price** because the selling price is usually larger than the cost. The business community reports whichever percent serves its purpose better. Your responsibility as an investor or consumer is to know which percent is reported and what it means to you.

Now work margin exercise 8.**Margin Exercise Answers**

1. a. 130 b. 352.4 c. 35% 2. a. \$13 b. \$39 3. \$150 4. \$41.73 5. \$2682 6. 4% 7. 3%
8. a. \$60 b. 120% c. $\approx 54.55\%$

4.7 Exercises

Concept Check

Fill-in-the-Blank. Complete each sentence using information found in this section.

- The final step in solving word problems is to _____ over the result to see if the result is reasonable.
- The amount of reduction in the original selling price is called a/an _____. The reduced price is the _____ price.
- Sales tax is a percentage of the _____ price. This tax is added to the buyer's cost.
- The fee paid to an agent or salesperson for a service is called a/an _____.
- If the value of an item increases, the increase in value can be called _____.
- Percent of profit can be based on either _____ or _____ price.

True/False. Determine whether each statement is true or false. If a statement is false, explain how it can be changed so the statement will be true. (**Note:** There may be more than one acceptable change.)

-
7. If an item is selling for a 35% discount, the customer will pay 65% of the original price.
 8. If you must pay 7% sales tax on a purchase, the total cost you will pay is 170% of the total before tax.
 9. A car was purchased in 1965 for \$3800. It sold for \$1200 in 2011. This is an example of depreciation.
 10. Profit is determined by subtracting selling price from the cost.

Practice

Change each value to a percent.

-
- | | |
|------------------|---------------------|
| 1. 0.91 | 6. $\frac{87}{100}$ |
| 2. 0.625 | 7. $1\frac{1}{2}$ |
| 3. 1.37 | 8. $\frac{2}{3}$ |
| 4. 0.0075 | |
| 5. $\frac{3}{8}$ | |

Change each percent to a decimal number.

-
- | | |
|-----------|-----------|
| 9. 69% | 13. 0.5% |
| 10. 7.5% | 14. 235% |
| 11. 11.3% | 15. 82% |
| 12. 162% | 16. 31.4% |

Change each percent to a reduced fraction.

-
- | | |
|---------|----------|
| 17. 35% | 19. 130% |
| 18. 72% | 20. 40% |

Use the equation $R \cdot B = A$ to find each unknown quantity. Round percents to the nearest tenth of a percent. All other answers should be rounded to the nearest hundredth, if necessary. See Example 1.

-
- | | |
|---------------------------------|-------------------------------|
| 21. 10% of 70 is what number? | 24. 17 is 20% of what number? |
| 22. What percent of 32 is 30.4? | 25. ____% of 34 is 17. |
| 23. Find 15.2% of 75. | 26. 12% of ____ is 15. |

Applications

Solve.







27. A television which normally sells for \$300 is priced at a 10% discount.
 - a. Find the amount of the discount.
 - b. Find the sale price.
28. A new briefcase was priced at \$275. Suppose that it were marked down 30%.
 - a. What would be the amount of the discount?
 - b. What would be the new price?
29. A store owner received a 3% discount from the manufacturer when she bought \$15,500 worth of dresses.
 - a. What was the amount of the discount?
 - b. What did she pay for the dresses?
30. In order to get more subscribers, a book club offered three books for a total price of \$7.02. The total selling price was originally \$17.55 for all three books.
 - a. What was the amount of the discount?
 - b. Based on the original selling price, what was the rate of the discount on these three books?
31. Sheets are marked \$22.50 and pillowcases \$7.50. What is the sale price of each item if each item is discounted 25% off the marked price?
32. Towels were on sale at a discount of 30%. If the sale price was \$3.01, what was the original price?
33. Headphones were on sale for \$49.00. What was the original price if the sale price represents a discount of 20%?
34.  An auto supply store received a shipment of auto parts and a bill for \$845.30. Some of the parts were not as ordered, and they were returned immediately. The value of the parts returned was \$175.50. The terms of the billing provided the store with a 2% discount if it paid with cash (for the parts it kept) within two weeks. What did the store pay for the parts it kept if it paid cash within two weeks?
35. In the roofing business, shingles are sold by the “square,” which is enough material to cover a 10 ft by 10 ft square (or 100 square feet). A roofing supplier has a closeout on shingles at a 30% discount.
 - a. If the original price was \$230 per square, what is the sale price per square?
 - b. How much would a roofer pay for 34 squares?
36. An auto dealer paid \$8730 for a large order of special parts. This was not the original price. The amount paid reflects a 3% discount off the original price because the dealer paid cash. What was the original price of the parts?
37. If the sales tax rate is 6.5%, what is the tax on an \$800 purchase?



Why Do Bostonians Shop in New Hampshire?

Sales taxes are not the same everywhere. Different states have different sales tax rates. Within a state, different localities may have different rates. In California, for example, the 2019 minimum sales tax rate is 7.25%, but within Los Angeles County, the rate is at least 9.5% and as high as 10.5% in the city of Santa Fe Springs. At the other extreme, five states in the United States don't have sales tax: Alaska, Delaware, Montana, New Hampshire, and Oregon. And that's why people from Boston go shopping in New Hampshire.

38. The sales tax in a certain state is figured at 6%.
- How much tax is there on a purchase of \$30.20?
 - What is the total amount paid for the purchase?
39. Suppose sales tax is figured at 6%.
- How much tax would be paid on the purchase of three textbooks priced at \$55.00, \$25.50, and \$43.95?
 - What would be the total cost of all three books?
40. If sales tax is figured at 7.25%, how much tax will be added to the total purchase price of three textbooks priced at \$25.00, \$35.00, and \$52.00?
41. The property taxes on a house were \$1050. What was the tax rate if the house was valued at \$70,000?
42. The discount on a computer was \$150. This was a 20% discount.
- What was the original selling price of the computer?
 - What was the sale price?
 - What was the total amount paid for the computer if a 6% sales tax was added to the sale price?
43. The discount on men's suits was \$50, and they were on sale for \$200.
- What was the original selling price?
 - What was the rate of discount?
 - What was the total amount paid for the suit if an 8% sales tax was added to the sale price?
44.  Taylor is enrolled in a calculus course. She has the choice of buying the text in hardback form for \$60.00 or in paperback form for \$46.50. Tax is figured at 5% of the selling price. The bookstore buys back hardback books for 40% of the selling price and paperback books for 30% of the selling price.
- Which book is the more economical buy for Taylor if she sells her book back to the bookstore at the end of the semester?
 - How much does she save?
45. A realtor works on 6% commission. What is his commission on a house he sold for \$195,000?
46. A realtor selling commercial property works on a 4% commission. What is her commission on a building she sold for \$875,000?
47. A car saleswoman earns a commission of 7% on each car she sells. How much did she earn on the sale of a car for \$12,500?
48. A realtor works on 6% commission. What is his commission on a house he sold for \$125,000?
49. If a salesman works on a 10% commission (no monthly salary), how much merchandise will he have to sell to earn \$2800 in one month?







50. A realtor works on a 5% commission. How much would she need to sell a house for in order to earn \$24,250 in commission?
51. A sales clerk receives a monthly salary of \$500 plus a commission of 6% on all sales over \$3500. What did the clerk earn the month she sold \$8000 in merchandise?
52. A sales clerk receives a monthly salary of \$1295 plus a commission of 7% on all sales over \$2500. What did the clerk earn the month she sold \$16,000 in merchandise?
53. A shoe saleswoman works on a fixed salary of \$1440 per month plus an 8% commission. How much did she make during the month in which she sold \$13,500 worth of shoes and accessories?
54.  Suppose you sell your home for \$180,000 and you owe the bank \$60,000 on the mortgage. You pay a real estate agent a commission of 6% of the selling price, and other fees and taxes totaling \$1200. How much money do you make from the sale?
55.  Suppose you sell your three-bedroom home for \$180,000 and you owe the balance of the mortgage of \$55,000 to the bank. You pay a real estate agent a fee of 6% of the selling price and other fees and taxes that total \$1500. How much money do you make from the sale?
56.  Scott is buying a beach house off the coast of South Carolina for \$260,000. The bank will loan him \$225,000. If he must also pay a 4% commission to the real estate agent and \$3800 in taxes and other fees, how much cash does he need?
57.  A computer programmer was told that he would be given a bonus of 5% of any money his programs could save the company. How much would he have to save the company to earn a bonus of \$500?
58. Central Valley Community College had 48 teams compete at their 3rd annual corn hole tournament. The following year they had 54 teams compete. What was the percent increase in competing teams?
59. Due to the increasing cost of breakfast cereals, more and more people are buying private-label brands rather than national brands. In a recent year, the sale of private-label cereals rose from 170 million boxes to 180 million boxes. What was the percent increase in sales (to the nearest tenth of a percent)?
60.  The decade from 1960 to 1970 saw the largest 10-year increase in the number of male elementary and high school teachers in our nation's history. There was an increase from 402,000 to 691,000. What was the percent increase from 1960 to 1970 (to the nearest one percent)?
61.  The average attendance to a Yankees game in 2009 was 45,364 fans. In 2010 the average attendance grew to 46,491 fans. Find the percent increase in attendance. Round your answer to the nearest thousandth.
62.  In 1966, the student enrollment at California Polytechnic State University in San Luis Obispo, CA, was 7740. In 1977, the university had 15,502 students. Since that time the enrollment growth has slowed. What was the percent increase of student enrollment during that eleven year period? Round your answer to the nearest tenth of a percent.¹



The 28/36 Rule

Nobody wants to lend money to someone who cannot pay it back. Banks use multiple measures to decide whether a borrower would qualify for a mortgage. The most important factor is how much you earn; the more money you make, the more banks are willing to lend to you. According to Investopedia, a general rule of thumb is that banks want their borrowers to spend no more than 28% of gross income on housing expenses (mortgage, insurance, condo fees) and no more than 36% on all debts (mortgage, car loans, student loans).

¹ Source: lib.calpoly.edu/universityarchives/history/timeline

63.  Frisco, Texas, had the largest population growth among large cities in 2022. In 2021, the population of Frisco was 208,262. The percent increase between 2021 and 2022 was 3.2%. What was the population of Frisco in 2022 (to the nearest whole number)?
64.  The population of the world was 7.9 billion in 2022 with an expected percent increase of 1% per year. At this rate of increase, what was the expected population of the world for the year 2024? Round your answer to the nearest tenth of a billion. (**Hint:** First find the expected population for 2023. Then use this answer to find the expected population for 2024.)²
65.  In April 2022, Best Buy sold a 12.9" iPad Pro for the reduced price of \$1599.99. The original price was \$1799.99.
- How much was the price reduced in terms of dollars?
 - Find the percent decrease or reduction. Round your answer to the nearest hundredth of a percent.
66.  The 2010 population of Wheeling, WV, was 43,002 while the 2015 population dropped to 42,573. What was the percent decrease of population in that five year period? Round your answer to the nearest tenth of a percent.³
67.  The circulation of the Washington Post newspaper was approximately 633,100 in 2009, and it dropped to 395,234 in 2015. What was the percent decrease in circulation? Round your answer to the nearest percent.⁴
68.  The Dow Jones Industrial Index had a peak of 13,930 in October of 2007, but dropped to a minimum of 7,063 in February 2009. Fortunately this dip was short lived, and the market started increasing again. What was the percent decrease in the stock market drop according to the Dow Jones Industrial Index during this sixteen month interval? Round your answer to the nearest tenth of a percent.⁵
69. A company manufactures and sells plastic boxes that cost \$21 each to produce, and that sell for \$28 each.
- How much profit does the company make on each box?
 - What is the percent of profit based on cost?
 - What is the percent of profit based on selling price?
70. Men's suits were on sale for \$300. Each one cost the store owner \$250.
- What was the profit for the store?
 - What as the store's percent profit based on cost?
 - What was the store's percent profit based on selling price?
71. The cost of a 65" smart TV to a store owner was \$450, and she sold the TV for \$630.
- What was her profit?
 - What was her percent of profit based on cost?
 - What as her percent of profit based on selling price?

2 Source: Worldometer, www.worldometers.info/world-population

3 Source: www.city-data.com/zips/26003.html

4 Source: <https://capitolcommunicator.com/washington-post-circulation-drops-37-percent-since-2009-states-dcrtv/>

5 Source: <https://stockcharts.com/freecharts/historical/marketindexes.html>

72. A set of golf clubs cost a golf pro \$400, and she sold them in the pro shop for \$550.
- What was her profit?
 - What was her percent of profit based on cost?
 - What was her percent of profit based on selling price?
73. An art gallery sells paintings by a local artist for \$2500 each. The gallery owner has agreed to pay the artist \$2000 for each painting of a certain size.
- What is the profit on each painting?
 - What is the percent of profit based on cost?
 - What is the percent of profit based on selling price?
74. The cost of an 85" smart TV to a store owner was \$3300 and he sold the TV for \$4500.
- What was his profit?
 - What was his percent of profit based on cost?
 - What was his percent of profit based on selling price?
75. The Golf Pro Shop had a set of 10 golf clubs that were marked on sale for \$860. This was a discount of 20% off the original selling price.
- What was the original selling price?
 - If the clubs cost the Golf Pro Shop \$602, what was its profit?
 - What was the shop's percent of profit based on the original selling price?
 - What was the percent of profit based on the sale price?
76. A car dealer bought a 10-year-old car for \$2500. He marked up the price so that he would make a profit of 25% based on his cost.
- What was the selling price?
 - If the customer paid 8% of the selling price in taxes and fees, what was the customer's total cost for the car?

Another common use of percent is to calculate the tip on a bill. Tips are most commonly left in restaurants, but also apply to any service-based industry. Solve each problem, using the guidelines outlined in the problem to find the tip.

-
77. You invited your friend to lunch at the local coffeehouse, and the bill totaled \$12.60. Your friend offered to leave the tip. What amount did he leave if he tipped 15% on the total bill?
78. Mrs. Chung had two large pizzas delivered to her home for \$26.00. If she tipped the delivery person 18%, what total amount did she pay the driver?
79. On a recent business trip, Ken and Joe had breakfast at the restaurant next to the motel where they were staying. Ken's breakfast bill was \$6.95 and Joe's was \$8.75. How much should each man have left as a tip if each tipped 20%?
80. The bill for a family dining at a restaurant was \$38.40. What would a 15% tip be? What total amount should they leave on the table if they want to go before the waiter comes to pick up the money?

81. Juan took his date out for dinner before the senior prom. The total bill, including tax, was \$48.00. How much did he tip the waitress if he left 18% (after tax)? What were his total expenses for the meal?
82. Walt decided to treat himself to lunch, and the bill was \$11.75, including tax. What amount did he leave as a 15% tip (after tax)? What was the total amount he paid for lunch?
83. A lawyer took four clients to dinner. The total bill for dinner and drinks was \$150.00 plus a 6% sales tax. What amount did she leave as a tip if she calculated the tip after tax at 20%?
84. A math teacher took two of her colleagues to dinner, and the bill was \$65.00 plus a 6% sales tax.
- What amount did she leave as a 20% tip (before tax)?
 - What was the total amount, including tip, she paid for the dinner?
85. Ann paid for lunch at the local pizza parlor for three of her study partners because they were celebrating having passed a statistics exam. The bill was \$18.00 plus tax at 5%.
- What amount did she leave as a 20% tip (before tax)?
 - What was the total amount of her bill, including tip and taxes?
86. On Monday night, Alondra and Parker decided to stay home, watch a football game, and have Chinese food delivered. If the bill was \$23.00 plus tax at 7.5% and they tipped the driver 15% of the bill (before tax), what total amount did they pay?
87. The coach invited the basketball team to his home after the last game of the season and had six large pizzas delivered. If the bill was \$90.00 plus tax at 6% and he gave the driver an 18% tip (before tax), what total amount did he pay?

Writing & Thinking

88. List the four basic steps for solving word problems. Of the four basic steps for solving word problems, which step do you think is the most important and why?
89. Determine how to calculate sales tax when eating out and relate this process to either a proportion and/or using the amount/base/rate equation. Give an example.
90. A man weighed 200 pounds. He lost 20 pounds in 3 months. Then he gained back 20 pounds 2 months later.
- What percent of his weight did he lose in the first 3 months?
 - What percent of his weight did he gain back?
 - The loss and gain are the same, but the two percentages are different. Explain why.
91. Explain the process to determine how to find percent of profit based on
- cost.
 - selling price.

Collaborative Learning

With the class separated into teams of two to four students, each team is to analyze the following problem and decide how to answer the related questions. Then each team leader is to present the team's answers and related ideas to the class for general discussion.

- 92.** Jerry works in a bookstore and gets a salary of \$500 per month plus a commission of 3% on whatever he sells. Wilma works in the same store, but she decided to work on a straight 8% commission.
- At what amount of sales will Jerry and Wilma make the same amount of money?
 - Up to that point, who will be making more?
 - After that point, who would be making more? Explain briefly. (If you were offered a job at this bookstore, which method of payment would you choose?)

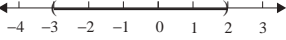
13.  14. The maximum final dosage that can be administered must be less than 400 milligrams. 15. Ashley can buy at most 8 rose centerpieces.

4.8 Exercises

Concept Check

Fill-in-the-Blank. Complete each sentence using information found in this section.

- If a and b are real numbers where $a < b$, the set of all real numbers between a and b is called a/an _____ of real numbers.
- In a/an _____ interval, neither endpoint is included.
- In a/an _____ interval, both end points are included.
- Linear inequalities are inequalities that relate two _____.
- If A and B are algebraic expressions and C is a real number, then the _____ principle for solving linear inequalities states that $A < B$ and $A + C < B + C$ are equivalent.
- If A and B are algebraic expressions and C is a real number, then the _____ principle for solving linear inequalities states that $A < B$ and $AC < BC$ are equivalent.

True/False. Determine whether each statement is true or false. If a statement is false, explain how it can be changed so the statement will be true. (**Note:** There may be more than one acceptable change.)

- If only one endpoint is included in an interval, it is called a half-open interval.
- When both sides of a linear inequality are multiplied by a negative constant, the sense of the inequality should stay the same.
- To check the solution set of a linear inequality, every solution in the solution set must be checked in the original inequality.
- The infinity symbol ∞ does not represent a specific number.

Practice





Graph each interval on a real number line. See Example 1.

- | | |
|-------------------|--------------------|
| 1. $(-1, \infty)$ | 5. $[-5, -1]$ |
| 2. $[-2, 4)$ | 6. $(3, 8)$ |
| 3. $(-\infty, 5]$ | 7. $[-7, -4)$ |
| 4. $[0, 3]$ | 8. $(-\infty, -6]$ |

Graph each interval on a real number line and tell what type of interval it is. See Examples 2 through 4.

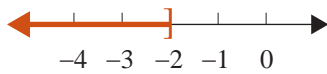
- | | |
|-------------------------|-------------------------|
| 9. $x \leq -3$ | 14. $-1.5 \leq x < 3.2$ |
| 10. $x \geq -0.5$ | 15. $-2 \leq x \leq 0$ |
| 11. $x > 4$ | 16. $-1 \leq x \leq 1$ |
| 12. $x < -\frac{1}{10}$ | 17. $4 > x \geq 2$ |
| 13. $0 < x \leq 2.5$ | 18. $0 > x \geq -5$ |

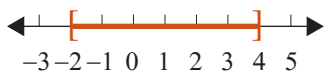
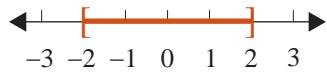
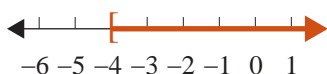
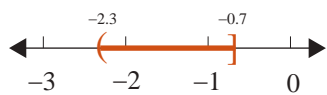
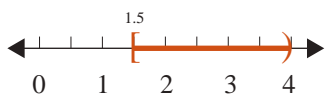
Represent each of the following graphs **a.** using algebraic notation and **b.** using interval notation and state what kind of interval it is.

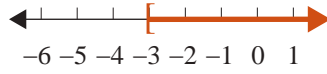
- | | |
|---|---|
| 19.  | 24.  |
| 20.  | 25.  |
| 21.  | 26.  |
| 22.  | 27.  |
| 23.  | 28.  |

Solve each inequality and graph the solution set. Write each solution set using interval notation.

- | | |
|---------------------|-------------------------|
| 29. $x + 1 > 5$ | 41. $10 > -5x$ |
| 30. $x - 3 < 2$ | 42. $12 < 8x$ |
| 31. $3 + x \leq 7$ | 43. $14 \geq 2x$ |
| 32. $5 + x \geq 11$ | 44. $9 \leq -3x$ |
| 33. $3 < 4 + x$ | 45. $2x + 3 < 5$ |
| 34. $9 > 6 + x$ | 46. $4x - 7 \geq 9$ |
| 35. $4 \geq x - 3$ | 47. $14 - 5x < 4$ |
| 36. $12 \leq x + 8$ | 48. $23 < 7x - 5$ |
| 37. $4x > 16$ | 49. $6x - 15 > 1$ |
| 38. $3x < 27$ | 50. $9 - 2x < 8$ |
| 39. $5x \leq 15$ | 51. $5.6 + 3x \geq 4.4$ |
| 40. $-2x \geq 6$ | 52. $12x - 8.3 < 6.1$ |

53. $1.5x + 9.6 < 12.6$
54. $0.8x - 2.1 \geq 1.1$
55. $2 + 3x \geq x + 8$
56. $x - 6 \leq 4 - x$
57. $3x - 1 \leq 11 - 3x$
58. $5x + 6 \geq 2x - 2$
59. $4 - 2x < 5 + x$
60. $4 + x > 1 - x$
61. $x - 6 > 3x + 5$
62. $4 + 7x \leq 4x - 8$
63. $\frac{x}{2} - 1 \leq \frac{5x}{2} - 3$
64. $\frac{x}{4} + 1 \leq 5 - \frac{x}{4}$
65. $\frac{x}{3} - 2 > 1 - \frac{x}{3}$
66. $\frac{5x}{3} + 2 > \frac{x}{3} - 1$
67. $6x + 5.91 < 1.11 - 2x$
68. $4.3x + 21.5 \geq 1.7x + 0.7$
69. $6.2x - 5.9 > 4.8x + 3.2$
70. $0.9x - 11.3 < 3.1 - 0.7x$
71. $4(6 - x) < -2(3x + 1)$
72. $-3(2x - 5) \leq 3(x - 1)$
73. $-(3x + 8) \geq 2(3x + 1)$
74. $6(3x + 1) < 5(1 - 2x)$
75. $11x + 8 - 5x \geq 2x - (4 - x)$
76. $1 - (2x + 8) < (9 + x) - 4x$
77. $5 - 3(4 - x) + x \leq -2(3 - 2x) - x$
78. $x - 2(x + 3) \geq 7 - (4 - x) + 11$
79. $\frac{2(x-1)}{3} < \frac{3(x+1)}{4}$
80. $\frac{3(x-2)}{2} \geq \frac{4(x-1)}{3}$
81. $\frac{x-2}{4} > \frac{x+2}{2} + 6$
82. $\frac{x+4}{9} \leq \frac{x}{3} - 2$
83. $\frac{2x+7}{4} \leq \frac{x+1}{3} - 1$
84. $\frac{4x}{7} - 3 > \frac{x-6}{2} - 4$
85. $-4 < x + 5 < 6$
86. $2 \leq -x + 2 \leq 6$
87. $3 \geq 4x - 3 \geq -1$
88. $13 > 3x + 4 > -2$
89. $1 \leq \frac{2}{3}x - 1 \leq 9$
90. $-2 \leq \frac{1}{2}x - 5 \leq -1$
91. $14 > -2x - 6 > 4$
92. $-11 \geq -3x + 2 > -20$
93. $-1.5 < 2x + 4.1 < 3.5$
94. $0.9 < 3x + 2.4 < 6.9$

Represent each of the following statements as an inequality involving a variable x , and graph its solution set on a number line.

95. You must be at least 58 inches in height to ride this roller coaster.
96. There are fewer than 12 days left before final exams.
97. Gifts worth \$5 or less do not need to be declared.
98. Arsenic levels over 10 parts per billion may be dangerous.

Applications

Solve.

- 99.** A statistics student has grades of 82, 95, 93, and 78 on four hour-long exams. He must average 90 or higher to receive an A for the course. What scores can he receive on the final exam and earn an A if:
- The final is equivalent to a single hour-long exam (100 points maximum)?
 - The final is equivalent to two hourly exams (200 points maximum)?
- 100.** To receive a grade of B in a chemistry class, Melissa must average 80 or more but less than 90. If her five hour-long exam scores were 75, 82, 90, 85, and 77, what score does she need on the final exam (100 points maximum) to earn a grade of B?
- 101.** A car salesman makes \$1000 each week that he works and makes approximately \$250 commission for each car he sells. If a car salesman wants to make at least \$3500 in one week, how many cars does he need to sell?
- 102.** Allison is ordering boxes of 24 tea bags from a website. The website is having a promotion where each box of tea comes with 2 free sample packs, and each sample pack contains 3 tea bags. If Allison has an empty container that holds 150 tea bags, what is the largest number of boxes of tea Allison can order and not overfill the container?
- 103.** WildLily Florist is creating arrangements for a wedding this weekend. The large arrangements use 8 flowers and the small arrangements use 5 flowers.
- Let x represent the number of large arrangements. Write an algebraic expression for the number of small arrangements, if there are 15 tables that need an arrangement.
 - Write an algebraic expression representing the total number of flowers used in the 15 arrangements.
 - If the bride has paid for 100 flowers, use an inequality to determine the maximum number of the 15 arrangements that can be large.
- 104.** John's algebra test consists of 19 questions, 13 equations and 6 word problems. Each equation is worth 4 points, and each word problem is worth 8 points. Assume there is no partial credit on this test.
- Let w be the number of word problems John gets correct. Write an expression for the number of points John will get from the word problem part of his test.
 - Assuming John gets every equation correct, write an inequality that will help determine the fewest number of word problems he can get correct and still make an 80 on the test. What is the fewest number he can get correct?
 - Let x be the number of equations John gets correct. Write an expression for the number of points John will get from the equation part of his test.
 - Assuming John gets every word problem correct, write an inequality that will help determine the fewest number of equations he can get correct and still get an 80 on the test. What is the fewest number of equations he can get correct?

105. Dr. Smyth has an attendance clause in his course syllabus that a student loses 5 points on his or her final grade average for every unexcused absence the student has after his or her first three unexcused absences. If Kara must have a 70 to pass the course, determine the largest number of unexcused absences Kara can have and still have any chance to pass the course.
106. Tracy needs to purchase 25 pastries for the PTA Teachers' Breakfast. Bear Claws cost \$1.75 each and Apple Turnovers cost \$2.15 each. If Tracy's budget is \$50, find the maximum number of Apple Turnovers that Tracy can purchase.
107. The maximum occupancy for a concert in Thompson-Boling Arena is 24,000 people. However, for every 15 tickets sold, there must be one worker present (security, food service, admissions, etc.). Determine the maximum number of tickets that can be sold.
108.  Phineas wants to build a nuclear-powered submarine to take his friends on a tour of the Arctic Circle. At least twice as much titanium must be used in the construction of the shell of the sub as the amount of stainless steel used in its construction. The cost of titanium is \$500 per pound and the cost of steel is \$300 per pound. If Phineas has only \$1,000,000 to spend on metal for the sub, determine the greatest number of pounds of metal (both together) that can be used to construct his submarine. (Round your answer to the nearest pound.)
109. Nicole has just moved to Orlando and discovered that Florida residents can purchase 4-day tickets to Disney World for \$55 per day. Annual passes (with certain restrictions) for Florida residents are \$390. Nicole is trying to decide if she thinks she will go to the park enough times to make it worth buying an annual pass. Use the formula $55x \leq 390$, where x is the number of days spent visiting at Disney World, to determine how many times she would have to go in order for the annual pass to be the better deal.
110. Fernando has already consumed 270 grams of carbohydrates and is on a diet that restricts his carbohydrate consumption to no more than 300 grams of carbohydrates per day. A serving of 6 crackers has 21 grams of carbohydrates. Solve the inequality $\frac{21}{6}c + 270 \leq 300$ to determine how many crackers (c) Fernando can eat without going over his goal. Write your answer as a whole number.
111. Jeph is in charge of buying office supplies for the nonprofit organization he works for. He has \$400 to spend. He needs to buy a printer that costs \$150, a box of printer paper for \$60, and some ink cartridges for \$12.50 each. What is the maximum number of ink cartridges that Jeph can buy? (**Note:** Tax is not included in the sales price.)
- Set up the linear inequality. Use the variable c to represent the number of ink cartridges.
 - Solve the equation from part a. for the variable.
 - What does the answer from part b. mean? Write a complete sentence.

- 112.** Sarah is participating in National Novel Writers Month where she has to write a rough draft of a novel with at least 50,000 words during the month of November. At the end of the day on November 20th, she has a total of 32,500 words. What is the minimum number of words that Sarah needs to write each day for the rest of the month to make the goal of 50,000 words?
- Set up the linear inequality. Use the variable w to represent the number of words per day.
 - Solve the equation from part a. for the variable.
 - What does the answer from part b. mean? Write a complete sentence.
- 113.** Andrew needs to earn at least a B in each class to keep his scholarship. The grade in his economics class is based on five exams that are equally weighted. On the first four exams, Andrew received the following scores: 92, 74, 80, 72. Andrew needs an average of at least 80 to earn a B for the class. What range of scores does he need on the fifth exam to keep his scholarship?
- Set up the linear inequality. Use the variable E to represent the fifth exam score.
 - Solve the equation from part a. for the variable.
 - What does the answer from part b. mean? Write a complete sentence.

Writing & Thinking

- 114.** **a.** Write a list of three situations where inequalities might be used in daily life.
- b.** Illustrate these situations with algebraic inequalities and appropriate numbers.

5.1 Exercises

Concept Check

Fill-in-the-Blank. Complete each sentence using information found in this section.

- The Cartesian coordinate system has a vertical and a horizontal line that separate a plane into four _____.
- In an ordered pair, x represents the _____ (first/second) coordinate and y represents the _____ (first/second) coordinate.
- If an ordered pair has two negative coordinates, the graph of the corresponding point is in Quadrant _____.
- If an ordered pair satisfies an equation, it is a/an _____ of the equation.
- The point of intersection of the x -axis and y -axis is called the _____.
- Linear equations have a/an _____ number of solutions.

True/False. Determine whether each statement is true or false. If a statement is false, explain how it can be changed so the statement will be true. (**Note:** There may be more than one acceptable change.)

- The graph of every ordered pair that has a positive x -coordinate and a negative y -coordinate can be found in Quadrant IV.
- To find the y -value that corresponds with $x = 2$, substitute 2 for x into the given equation and solve for y .
- If $(-7, 3)$ is a solution of $y = 3x + 24$, then $(-7, 3)$ satisfies $y = 3x + 24$.
- If point $A = (0, 4)$, then point A lies on the x -axis.

Practice

For each graph, list the set of ordered pairs corresponding to the points on the graph.

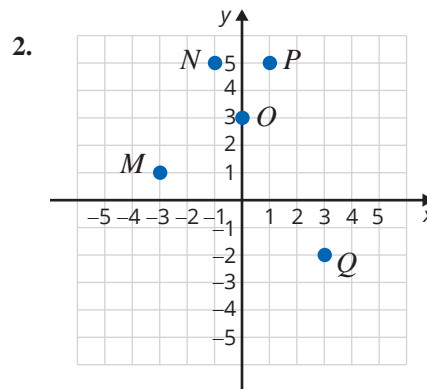
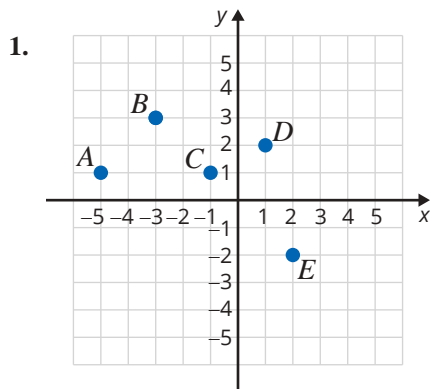

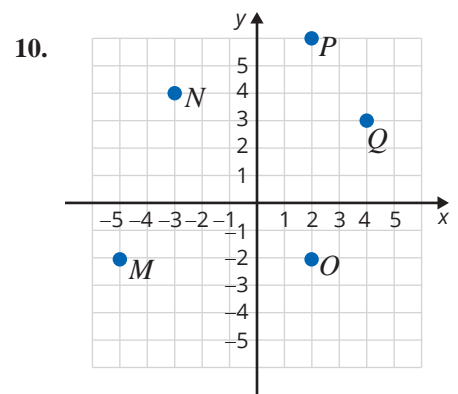
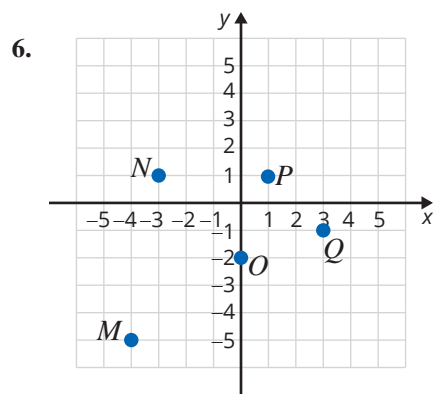
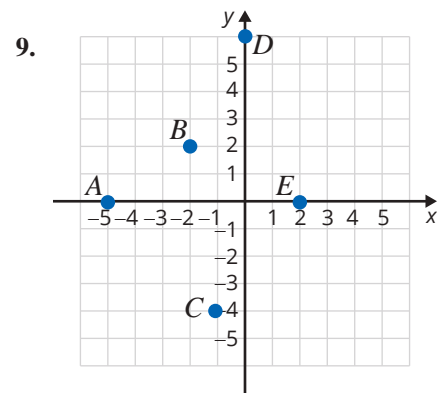
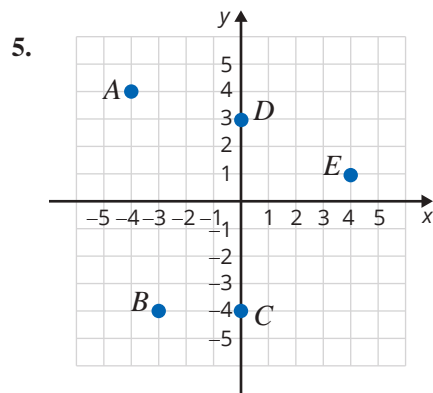
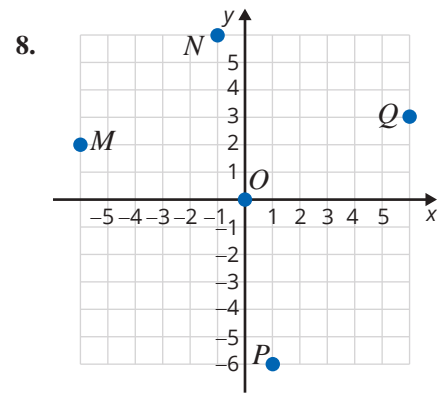
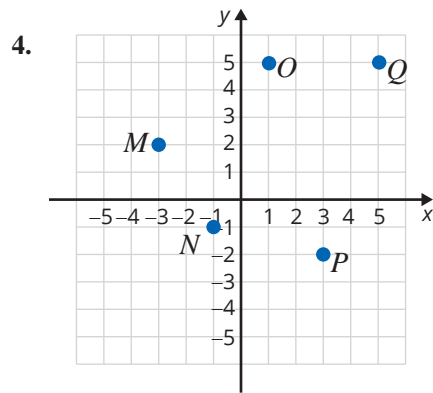
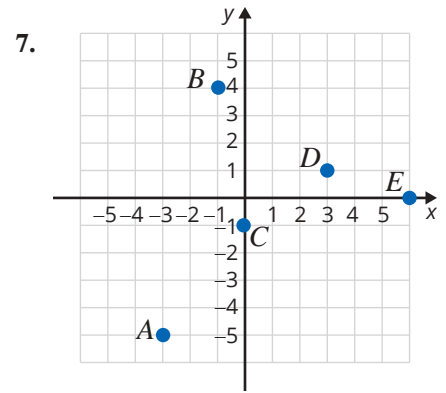
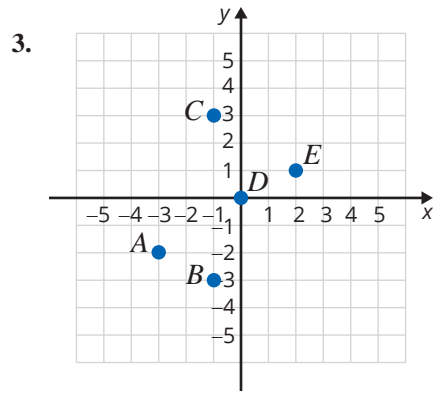

Plot each set of ordered pairs and label the points. See Examples 1 and 2.

11. $\{A(4, -1), B(3, 2), C(0, 5), D(1, -1), E(1, 4)\}$
12. $\{A(-1, -1), B(-3, -2), C(1, 3), D(0, 0), E(2, 5)\}$
13. $\{A(1, 2), B(0, 2), C(-1, 2), D(2, 2), E(-3, 2)\}$
14. $\{A(-1, 4), B(0, -3), C(2, -1), D(4, 1), E(-1, -1)\}$
15. $\{A(1, 0), B(3, 0), C(-2, 1), D(-1, 1), E(0, 0)\}$
16. $\{A(-1, -1), B(0, 1), C(1, 3), D(2, 5), E(3, 10)\}$
17. $\{A(4, 1), B(0, -3), C(1, -2), D(2, -1), E(-4, 2)\}$
18. $\{A(0, 1), B(1, 0), C(2, -1), D(3, -2), E(4, -3)\}$
19. $\{A(1, 4), B(-1, -2), C(0, 1), D(2, 7), E(-2, -5)\}$
20. $\{A(0, 0), B(-1, 3), C(3, -2), D(0, 4), E(-7, 0)\}$
21. $\left\{A(1, -3), B\left(-4, \frac{3}{4}\right), C\left(2, -2\frac{1}{2}\right), D\left(\frac{1}{2}, 4\right)\right\}$
22. $\left\{A\left(\frac{3}{4}, \frac{1}{2}\right), B\left(2, -\frac{5}{4}\right), C\left(\frac{1}{3}, -2\right), D\left(-\frac{5}{3}, 2\right)\right\}$
23. $\{A(1.6, -2), B(3, 2.5), C(-1, 1.5), D(0, -2.3)\}$
24. $\{A(-2, 2), B(-3, 1.6), C(3, 0.5), D(1.4, 0)\}$

Determine the missing coordinate in each of the ordered pairs so that the point will satisfy the equation given. See Example 3.

- | | |
|------------------------------|-----------------------------|
| 25. $x - y = 4$ | 27. $x + 2y = 6$ |
| a. $(0, \underline{\quad})$ | a. $(0, \underline{\quad})$ |
| b. $(2, \underline{\quad})$ | b. $(2, \underline{\quad})$ |
| c. $(\underline{\quad}, 0)$ | c. $(\underline{\quad}, 0)$ |
| d. $(\underline{\quad}, -3)$ | d. $(\underline{\quad}, 4)$ |
| 26. $x + y = 7$ | 28. $3x + y = 9$ |
| a. $(0, \underline{\quad})$ | a. $(0, \underline{\quad})$ |
| b. $(-1, \underline{\quad})$ | b. $(4, \underline{\quad})$ |
| c. $(\underline{\quad}, 0)$ | c. $(\underline{\quad}, 0)$ |
| d. $(\underline{\quad}, 3)$ | d. $(\underline{\quad}, 3)$ |

29. $4x - y = 8$

- a. $(0, \underline{\quad})$
- b. $(1, \underline{\quad})$
- c. $(\underline{\quad}, 0)$
- d. $(\underline{\quad}, 4)$

30. $x - 2y = 2$

- a. $(0, \underline{\quad})$
- b. $(4, \underline{\quad})$
- c. $(\underline{\quad}, 0)$
- d. $(\underline{\quad}, 3)$

31. $2x + 3y = 6$

- a. $(0, \underline{\quad})$
- b. $(-1, \underline{\quad})$
- c. $(\underline{\quad}, 0)$
- d. $(\underline{\quad}, -2)$

32. $5x + 3y = 15$

- a. $(0, \underline{\quad})$
- b. $(2, \underline{\quad})$
- c. $(\underline{\quad}, 0)$
- d. $(\underline{\quad}, 4)$

33. $3x - 4y = 7$

- a. $(0, \underline{\quad})$
- b. $(1, \underline{\quad})$
- c. $(\underline{\quad}, 0)$
- d. $(\underline{\quad}, \frac{1}{2})$

34. $2x + 5y = 6$

- a. $(0, \underline{\quad})$
- b. $(\frac{1}{2}, \underline{\quad})$
- c. $(\underline{\quad}, 0)$
- d. $(\underline{\quad}, 2)$

Complete the tables so that each ordered pair will satisfy the given equation. Plot the resulting sets of ordered pairs. See Example 4.

35. $y = 3x$

| x | y |
|-----|-----|
| 0 | |
| | -3 |
| -2 | |
| | 6 |

37. $y = 2x - 3$

| x | y |
|-----|-----|
| 0 | |
| | -1 |
| -2 | |
| | 3 |

36. $y = -2x$

| x | y |
|-----|-----|
| 0 | |
| | 4 |
| 3 | |
| | -2 |

38. $y = 3x + 5$

| x | y |
|-----|-----|
| 0 | |
| | -4 |
| -2 | |
| | 2 |

39. $y = 9 - 3x$

| x | y |
|-----|-----|
| 0 | |
| | 0 |
| 1 | |
| | -3 |

40. $y = 6 - 2x$

| x | y |
|-----|-----|
| 0 | |
| | 0 |
| -2 | |
| | -2 |

41. $y = \frac{3}{4}x + 2$

| x | y |
|-----|---------------|
| 0 | |
| | 5 |
| -4 | |
| | $\frac{5}{4}$ |

42. $y = \frac{3}{2}x - 1$

| x | y |
|-----|----------------|
| 0 | |
| | 2 |
| -2 | |
| | $-\frac{5}{2}$ |

43. $3x - 5y = 9$

| x | y |
|-----|-----|
| 0 | |
| | 0 |
| -2 | |
| | -1 |

44. $4x + 3y = 6$

| x | y |
|-----|-----|
| 0 | |
| | 0 |
| 3 | |
| | -1 |

45. $5x - 2y = 10$

| x | y |
|-----|-----|
| 0 | |
| | 0 |
| -1 | |
| | 5 |

46. $3x - 2y = 12$

| x | y |
|-----|-----|
| | 0 |
| 0 | |
| | -3 |
| 6 | |

47. $2x + 3.2y = 6.4$

| x | y |
|-----|------|
| 0 | |
| 3.2 | |
| | 0.8 |
| | -0.2 |

48. $3x + y = -2.4$

| x | y |
|-----|-----|
| | 0 |
| 0 | |
| | 0.6 |
| 1.6 | |

Determine which, if any, of the ordered pairs satisfy the given equation. See Example 5.

49. $y = 2x - 4$

- a. (1, 1)
- b. (2, 0)
- c. (1, -2)
- d. (3, 2)

50. $y = -4x + 5$

- a. $(\frac{3}{4}, 2)$
- b. (4, 0)
- c. (1, 1)
- d. (0, 3)

51. $x + 2y = -1$

- a. (1, -1)
- b. (1, 0)
- c. (2, 1)
- d. (3, -2)

52. $2x - 3y = 7$

- a. (1, 3)
- b. $(\frac{1}{2}, -2)$
- c. $(\frac{7}{2}, 0)$
- d. (2, 1)

53. $2x + 5y = 8$

- a. (4, 0)
- b. (2, 1)
- c. (1, 1.2)
- d. (1.5, 1)

54. $3x + 4y = 10$

- a. (-2, 3)
- b. (0, 2.5)
- c. (4, -2)
- d. (1.2, 1.6)

The graph of a line is shown. List any three points on each line. (There is more than one correct answer.) See Example 6.

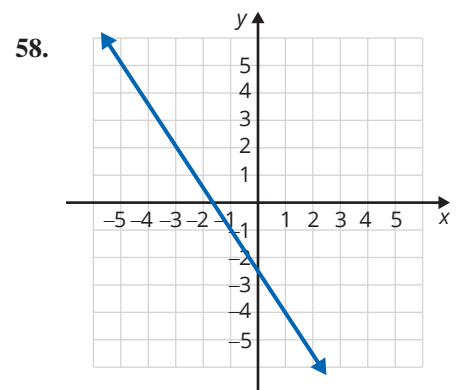
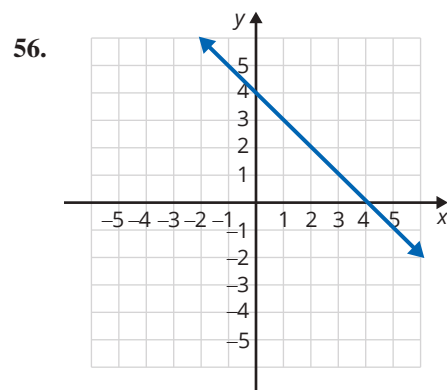
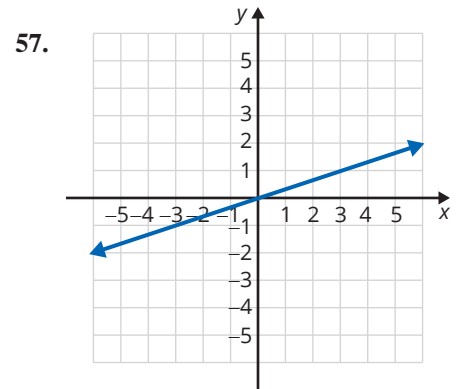
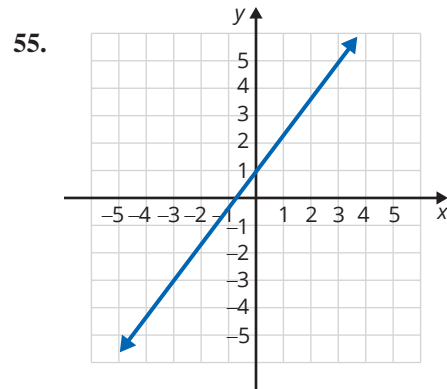

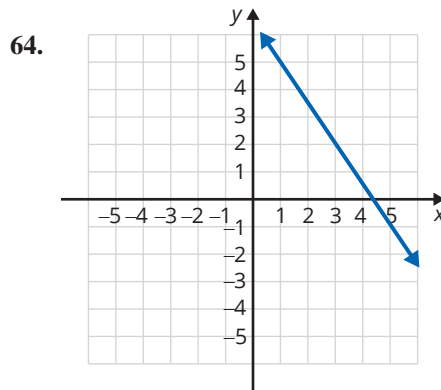
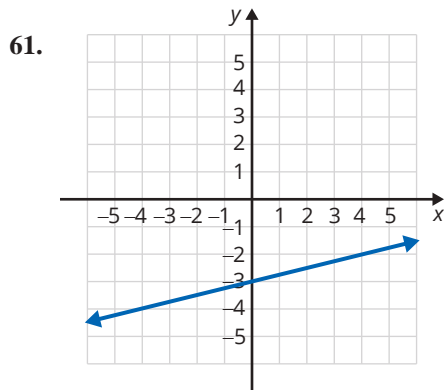
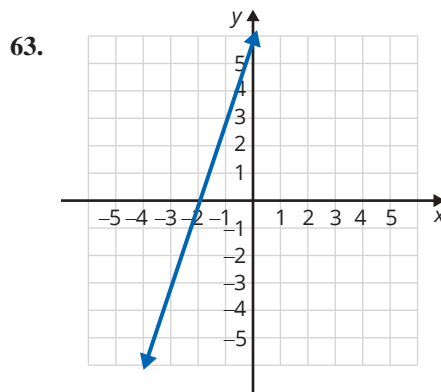
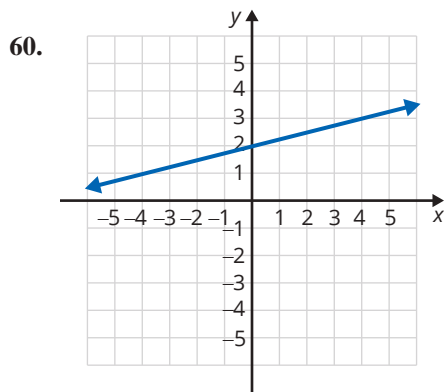
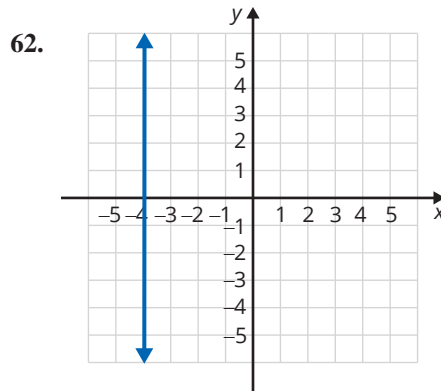
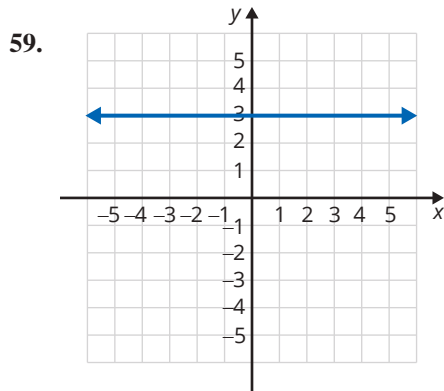

Applications

Solve.

65. At one point in 2017, the exchange rate from US dollars to Euros was $E = 0.85D$ where E is Euros and D is dollars.
- Make a table of ordered pairs for the values of D and E if D has the values \$100, \$200, \$300, \$400, and \$500.
 - Plot the points corresponding to the ordered pairs.
66. Consider the equation $F = \frac{9}{5}C + 32$, where C is temperature in degrees Celsius and F is the corresponding temperature in degrees Fahrenheit.
- Make a table of ordered pairs for the values of C and F if C has the values -20° , -10° , -5° , 0° , 5° , 10° , and 15° .
 - Plot the points corresponding to the ordered pairs.

67.  Consider the equation $d = 16t^2$, where d is the distance an object falls in feet and t is the time in seconds that the object falls.
- Make a table of ordered pairs for the values of t and d with the values of 1, 2, 3.5, 4, 4.5, and 5 seconds for t .
 - Plot the points corresponding to the ordered pairs.
 - These points do not lie on a straight line. What feature of the equation might indicate to you that the graph is not a straight line?
68. Consider the equation $V = 9h$, where V is the volume (in cubic centimeters) of a box with a variable height h in centimeters and a fixed base of area 9 cm^2 .
- Make a table of ordered pairs for the values of h and V with h as the values 2 cm, 3 cm, 5 cm, 8 cm, 9 cm, and 10 cm.
 - Plot the points corresponding to the ordered pairs.
69. A business owner records the number of customers per hour to determine peak shopping times after noon. Graph the points corresponding to the ordered pairs.

| Hour of the Day | 1 p.m. | 2 p.m. | 3 p.m. | 4 p.m. | 5 p.m. | 6 p.m. | 7 p.m. | 8 p.m. |
|---------------------|--------|--------|--------|--------|--------|--------|--------|--------|
| Number of Customers | 500 | 450 | 200 | 650 | 900 | 700 | 550 | 300 |

70. One way to describe locations on a map is to lay a grid on top of the map and define locations with an ordered pair. A map with an overlaid grid is called a **grid reference**. Typically the origin of the coordinate system is placed at the bottom left corner of the map and vertical and horizontal lines are extended from each reference point on the axes.
- A city planning committee is using a map with a grid system to plot the locations in a portion of the city where the highest frequency of traffic accidents occurs. The map is shown here with the highest accident points indicated with a star. A proposal is made to replace stop signs with electric traffic signals at every intersection that has a high frequency of accidents.

- Will a traffic signal be placed at any of the following points? If so, which points?
 $(2, 1)$, $(4, 4)$, $(0, 5)$
- Which points not listed in part a. will have traffic signals?

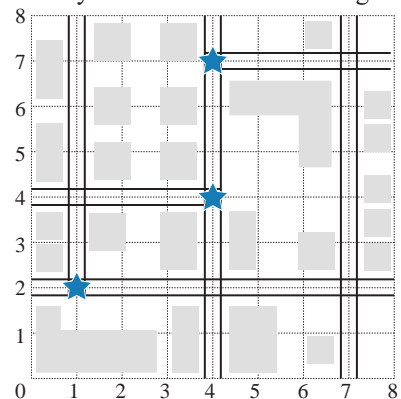

71. The equation $t = \frac{d}{r}$ can be used to determine how long it will take you to travel a certain distance while traveling at a specified rate, or speed. Suppose you have to travel a distance of 150 miles. (**Hint:** Rate is in miles per hour, time is in hours, and distance is in miles.)

- a. Complete the table of values.

| r (mph) | t (hours) |
|-----------|-------------|
| 25 | |
| 50 | |
| 60 | |

- b. Graph the ordered pairs from the table. Try using a scale of 10 for each increment on the r -axis.
- c. What happens to the value of time as the rate increases?

- d. Complete the table of values. You may want to solve the given equation, $t = \frac{d}{r}$, for r first. Remember that $d = 150$ miles.

| r (mph) | t (hours) |
|-----------|-------------|
| | 5 |
| | 2.5 |
| | 1 |
| | 0.5 |
| | 0.1 |

- e. As the value of t gets smaller (and closer to zero), how does the rate change?

72. Suppose you deposit \$1000 into an account that earns simple interest at a rate of 4%. Use the simple interest formula $I = Prt$ to solve the following problems.

- a. Fill in the given table to determine the amount of interest earned if you keep the deposit in the account for 3 months, 6 months, 1 year, 2 years, and 3 years.

| t (years) | I (\$) |
|---------------|----------|
| $\frac{1}{4}$ | |
| $\frac{1}{2}$ | |
| 1 | |
| 2 | |
| 3 | |

- b. Plot the ordered pairs from the table in part a. on the coordinate plane and draw a line through the points.
- c. Since graphs are models of situations, they can be used to predict values. Use the graph to predict the amount of interest that will be earned after 9 months. (Remember to convert the time to years.)
- d. Use the graph to predict the amount of interest that will be earned after one and a half years.

Writing & Thinking

In statistics, data is sometimes given in the form of ordered pairs where each ordered pair represents two pieces of information about one person. For example, ordered pairs might represent the height and weight of a person or the person's number of years of education and that person's annual income. The ordered pairs are plotted on a graph and the graph is called a **scatter diagram (or scatter plot)**. Such scatter diagrams are used to see if there is any pattern to the data and, if there is, then the diagram is used to predict the value for one of the variables if the value of the other is known. For example, if you know that a person's height is 5 ft 6 in., then his or her weight might be predicted from information indicated in a scatter diagram that has several points of known information about height and weight.

73. a. The following table of values indicates the number of push-ups and the number of sit-ups that ten students did in a physical education class. Plot these points in a scatter diagram.

| Person | #1 | #2 | #3 | #4 | #5 | #6 | #7 | #8 | #9 | #10 |
|----------------|----|----|----|----|----|----|----|----|----|-----|
| x (push-ups) | 20 | 15 | 25 | 23 | 35 | 30 | 42 | 40 | 25 | 35 |
| y (sit-ups) | 25 | 20 | 20 | 30 | 32 | 36 | 40 | 45 | 18 | 40 |

- b. Does there seem to be a pattern in the relationship between push-ups and sit-ups? What is this pattern?
- c. Using the scatter diagram in part a., predict the number of sit-ups that a student might be able to do if he or she has just done each of the following numbers of push-ups: 22, 32, 35, and 45. (**Note:** In each case, there is no one correct answer. The answers are only estimates based on the diagram.)
74. Ask ten friends or fellow students what their heights and shoe sizes are. (You may want to ask all men or all women since the scales for men's and women's shoe sizes are different.) Organize the data in table form and then plot the corresponding scatter diagram. Knowing your own height, does the pattern indicated in the scatter diagram seem to predict your shoe size?
75. Ask ten friends or fellow students what their heights and ages are. Organize the data in table form and then plot the corresponding scatter diagram. Knowing your own height, does the pattern indicated in the scatter diagram seem to predict your age? Do you think that all scatter diagrams can be used to predict information related to the two variables graphed? Explain.

5.2 Exercises

Concept Check

Fill-in-the-Blank. Complete each sentence using information found in this section.

1. If 0 is substituted for x in a linear equation and the resulting equation is solved for y , the result will be the ___-intercept.
2. If 0 is substituted for y in a linear equation and the resulting equation is solved for x , the result will be the ___-intercept.
3. The solution set for linear equations is a/an _____ set of ordered pairs.
4. The standard form of a linear equation is _____.
5. The graph of every linear equation is a/an _____.
6. The graph of a line is determined by ___ points.

True/False. Determine whether each statement is true or false. If a statement is false, explain how it can be changed so the statement will be true. (**Note:** There may be more than one acceptable change.)

7. The y -intercept is the point where a line crosses the y -axis.
8. The terms ordered pair and point are used interchangeably.
9. A horizontal line does not have a y -intercept.
10. All x -intercepts correspond to an ordered pair of the form $(0, y)$.

Practice

Use your knowledge of y -intercepts and x -intercepts to match each of the following equations with its graph.

1. $4x + 3y = 12$

2. $4x - 3y = 12$

3. $x + 2y = 8$

4. $-x + 2y = 8$

5. $x + 4y = 0$

6. $5x - y = 10$

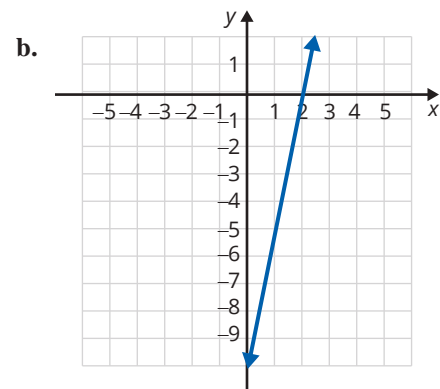
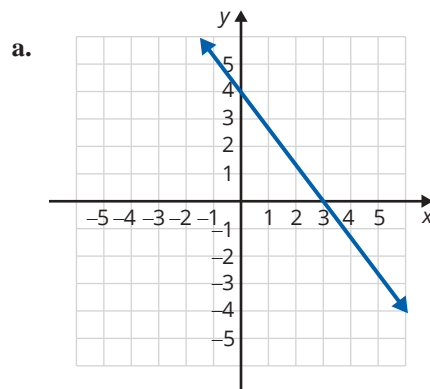

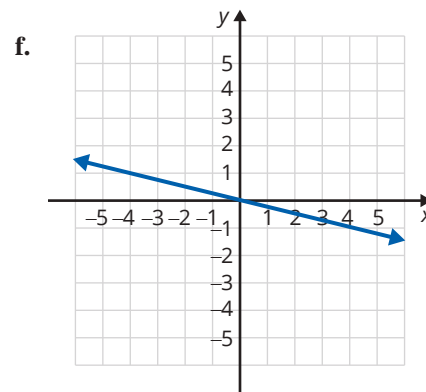
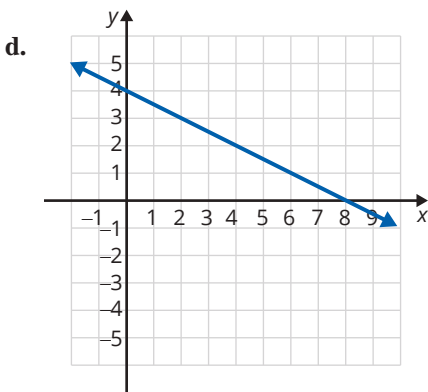
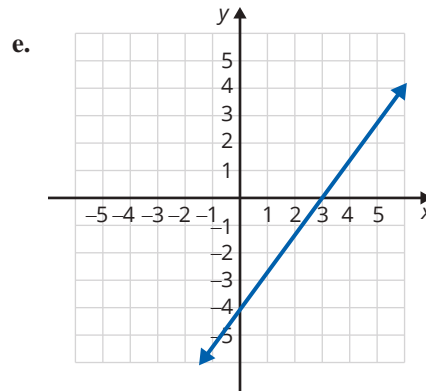
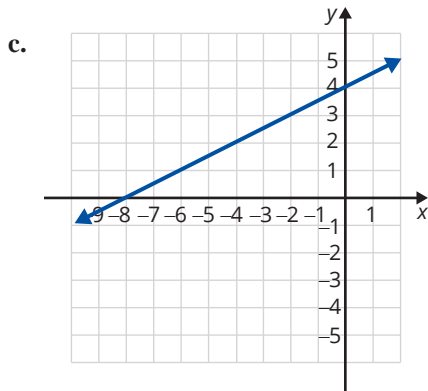

Graph each linear equation by locating at least two ordered pairs that satisfy the given equation. See Examples 1 through 3.

- | | | |
|--------------------|--------------------|-----------------------------|
| 7. $x + y = 3$ | 19. $y + 1 = 0$ | 30. $5x - 3y = -1$ |
| 8. $x + y = 4$ | 20. $y = 4x + 4$ | 31. $5x - 2y = 7$ |
| 9. $y = x$ | 21. $y = x + 2$ | 32. $y - 3 = 1$ |
| 10. $2y = x$ | 22. $x - 4 = -1$ | 33. $3x + 4y = 7$ |
| 11. $2x + y = 0$ | 23. $3y = 2x - 4$ | 34. $\frac{2}{3}x - y = 4$ |
| 12. $x = 1$ | 24. $y = -3$ | 35. $x + \frac{3}{4}y = 6$ |
| 13. $3x + 2y = 0$ | 25. $4x = 3y + 8$ | 36. $2x + \frac{1}{2}y = 3$ |
| 14. $2x + 3y = 7$ | 26. $3x + 5y = 6$ | 37. $y + 2 = 3$ |
| 15. $x + 2 = 0$ | 27. $2x + 7y = -4$ | 38. $\frac{2}{5}x - 3y = 5$ |
| 16. $4x + 3y = 11$ | 28. $2x + 3y = 1$ | 39. $5x = y + 2$ |
| 17. $3x - 4y = 12$ | 29. $x + 5 = 6$ | 40. $4x = 3y - 5$ |
| 18. $2x - 5y = 10$ | | |

Graph each linear equation by locating the x -intercept and the y -intercept. See Examples 4 through 6.

41. $x + y = 6$

42. $x + y = 4$

43. $x - 2y = 8$

44. $x - 3y = 6$

45. $4x + y = 8$

46. $x + 3y = 9$

47. $x - 4y = -6$

48. $x - 6y = 3$

49. $y = 4x - 10$

50. $y = 2x - 9$

51. $3x - 2y = 6$

52. $5x + 2y = 10$

53. $2x + 3y = 12$

54. $3x + 7y = -21$

55. $3x - 7y = -21$

56. $3x + 2y = 15$

57. $5x + 3y = 7$

58. $2x + 3y = 5$

59. $y = \frac{1}{2}x - 4$

60. $y = -\frac{1}{3}x + 3$

61. $\frac{2}{3}x - 3y = 4$

62. $\frac{1}{2}x + 2y = 3$

63. $\frac{1}{2}x - \frac{3}{4}y = 6$

64. $\frac{2}{3}x + \frac{4}{3}y = 8$

Applications

Solve.

65. The amount of potassium in a clear bottle of a popular sports drink declines over time when exposed to the UV lights found in most grocery stores. The amount of potassium in a container of this sports drink is given by the equation $y = -30x + 360$, where y represents the mg of potassium remaining after x days on the shelf. Find both the x -intercept and y -intercept, and interpret the meaning of each in the context of this problem.
66. Mr. Adler has found that the grade each student gets in his Introductory Algebra course directly correlates with the amount of time spent doing homework and is represented by the equation $y = 7x + 30$, where y represents the numerical score the student receives on an exam (out of 100 points) after spending x hours per week doing homework. Find the y -intercept and interpret its meaning in this context.
67. Barbara's Bombtastic Bakery is donating cookies to a charity bake sale. The bakery decides to donate chocolate chip cookies and peanut butter cookies by the dozen, and they want to donate a total of 30 dozen cookies. To determine the possible combinations, the bakery uses the equation $C + P = 30$, where C is the number of dozens of chocolate chip cookies and P is the number of dozens of peanut butter cookies.
- Find the intercepts of the given equation.
 - Graph the equation using the intercepts.
 - Are there any solutions to the equation that do not make sense in the context of the problem? Explain why.
 - If Barbara's Bombtastic Bakery decides to donate 16 dozen peanut butter cookies, how many dozen chocolate chip cookies will be donated?

68. Ibuprofen can be given to a child to treat a fever. For a fever lower than 102.5°F , the recommended dosage is 2.2 milligrams per pound of body weight. This can be modeled by the equation $D = 2.2w$, where D is the dosage of ibuprofen in milligrams and w is the weight of the child in pounds.
- Create a table to determine several coordinate pairs that satisfy the equation.
 - Graph the equation using the coordinate pairs from part a.
 - Are there any solutions from the graph that do not make sense in the context of the problem? Explain why.
 - How much ibuprofen should be given to a child that weighs 45 pounds?
69. Mason purchased a card game for \$20. The 5-card expansion packs cost \$1 per pack. Mason wants to keep track of how much money he spends on the game, so he creates the equation $C = 20 + 1n$, where C is the total cost in dollars and n is the number of expansion packs purchased.
- Create a table to determine several coordinate pairs that satisfy the equation.
 - Graph the equation using the coordinate pairs from part a.
 - Are there any solutions from the graph that do not make sense in the context of the problem? Explain why.
 - If Mason buys 37 expansion packs, what will the total cost be?

Writing & Thinking

70. Explain, in your own words, why it is sufficient to find the x -intercept and y -intercept to graph a line (assuming that they are not the same point).
71. Explain, in your own words, how you can determine if an ordered pair is a solution to an equation.

E Finding Equations of Lines Given the Slope and the y-Intercept

7. Find the equation of the line through the point $(0, -3)$ with a slope of $\frac{2}{3}$.

Example 7 Finding Equations Given the Slope and the y-Intercept

Find the equation of the line through the point $(0, -2)$ with slope $\frac{1}{2}$.

Solution

Because the x -coordinate is 0, we know that the point $(0, -2)$ is the y -intercept. So $b = -2$. The slope is $\frac{1}{2}$. So $m = \frac{1}{2}$. Substituting in slope-intercept form, $y = mx + b$, gives the result $y = \frac{1}{2}x - 2$.

Now work margin exercise 7.

Margin Exercise Answers

1. slope = 3

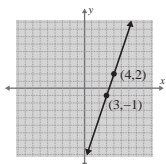

2. slope = $-\frac{3}{4}$

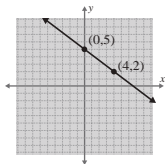

3. $y = -2$; slope is 0
4. $x = 2$; slope is undefined

5. $m = 2$; y -intercept = $(0, 6)$

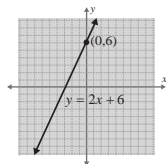

6. $m = -\frac{3}{2}$; y -intercept = $(0, -5)$

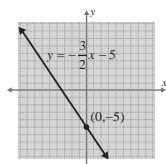

7. $y = \frac{2}{3}x - 3$

5.3 Exercises

Concept Check

Fill-in-the-Blank. Complete each sentence using information found in this section.

- The slope of a line is the ratio of rise to _____.
- Another name for slope is the rate of _____.
- A line that rises (increases) from left to right has a/an _____ slope.
- The slope of every vertical line is _____.
- The slope of every horizontal line is _____.
- In the equation $y = mx + b$, m represents the _____ and $(0, b)$ represents the _____.

True/False. Determine whether each statement is true or false. If a statement is false, explain how it can be changed so the statement will be true. (**Note:** There may be more than one acceptable change.)

7. If the y -intercept and the slope of a line are given, there is enough information to write the equation of the line.
8. When using the slope formula, the slope of a line changes if the order of the points is reversed.
9. A line that falls (decreases) from left to right has a negative slope.
10. The line that represents the equation $y = 2x + 4$ has a y -intercept of $(0, 4)$.

Practice

Find the slope of the line determined by each pair of points. See Examples 1 and 2.

1. $(2, 4); (1, -1)$
2. $(1, -2); (1, 4)$
3. $(-6, 3); (1, 2)$
4. $(-3, 7); (4, -1)$
5. $(-5, 8); (3, 8)$
6. $(-2, 3); (-2, -1)$
7. $(5, 1); (3, 0)$
8. $(0, 0); (-2, -3)$
9. $\left(\frac{3}{4}, \frac{3}{2}\right); (1, 2)$
10. $\left(4, \frac{1}{2}\right); (-1, 2)$
11. $\left(\frac{3}{2}, \frac{4}{5}\right); \left(-2, \frac{1}{10}\right)$
12. $\left(\frac{7}{2}, \frac{3}{4}\right); \left(\frac{1}{2}, -3\right)$

Determine whether each equation represents a horizontal line or vertical line and give its slope. Graph the line. See Examples 3 and 4.

13. $y = 5$
14. $y = -2$
15. $x = -3$
16. $x = 1.7$
17. $3y = -18$
18. $4x = 2.4$
19. $-3x + 21 = 0$
20. $2y + 5 = 0$

Write each equation in slope-intercept form. Find the slope and y -intercept, and then use them to draw the graph. See Examples 5 and 6.

21. $y = 2x - 1$
22. $y = 3x - 4$
23. $y = 5 - 4x$
24. $y = 4 - x$
25. $y = \frac{2}{3}x - 3$
26. $y = \frac{2}{5}x + 2$
27. $x + y = 5$
28. $x - 2y = 6$
29. $x + 5y = 10$
30. $4x + y = 0$
31. $4x + y + 3 = 0$
32. $2x + 7y + 7 = 0$
33. $2y - 8 = 0$

- | | | |
|------------------|--------------------|-----------------------|
| 34. $3y - 9 = 0$ | 39. $5x - 6y = 18$ | 44. $7x + 2y = 4$ |
| 35. $2x = 3y$ | 40. $3x + 6 = 6y$ | 45. $6y = -6 + 3x$ |
| 36. $4x = y$ | 41. $5 - 3x = 4y$ | 46. $4x = 3y - 7$ |
| 37. $3x + 9 = 0$ | 42. $5x = 11 - 2y$ | 47. $5x - 2y + 5 = 0$ |
| 38. $4x + 7 = 0$ | 43. $6x + 4y = -8$ | 48. $6x + 5y = -15$ |

In reference to the equation $y = mx + b$, sketch the graphs of three lines for each of the two characteristics listed below.

- | | |
|-------------------------|-------------------------|
| 49. $m > 0$ and $b > 0$ | 51. $m > 0$ and $b < 0$ |
| 50. $m < 0$ and $b > 0$ | 52. $m < 0$ and $b < 0$ |

Find an equation in slope-intercept form for the line passing through the given point with the given slope. See Example 7.

- | | | |
|--------------------------------|----------------------|---------------------------------|
| 53. $(0, 3); m = -\frac{1}{2}$ | 57. $(0, -5); m = 4$ | 61. $(0, -3); m = -\frac{5}{6}$ |
| 54. $(0, 2); m = \frac{1}{3}$ | 58. $(0, 9); m = -1$ | 62. $(0, -1); m = -\frac{3}{2}$ |
| 55. $(0, -3); m = \frac{2}{5}$ | 59. $(0, -4); m = 1$ | |
| 56. $(0, -6); m = \frac{4}{3}$ | 60. $(0, 6); m = -5$ | |

The graph of a line is shown with two points labeled. Find **a.** the slope, **b.** the y-intercept (if there is one), and **c.** the equation of the line in slope-intercept form.

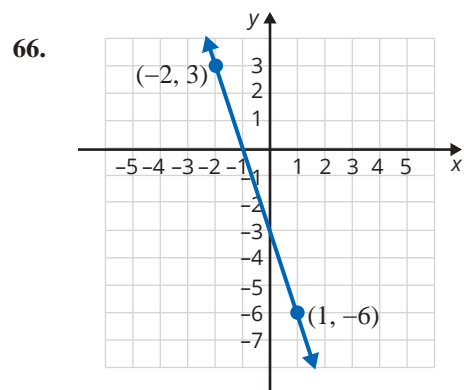
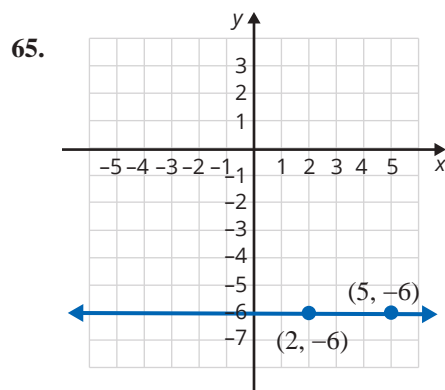
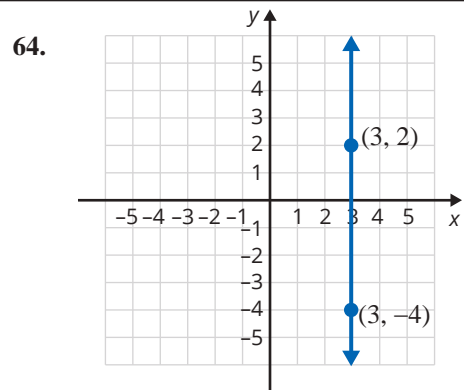
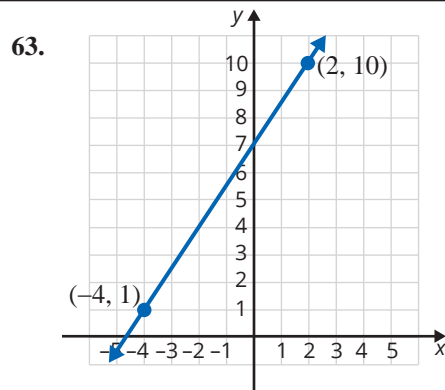

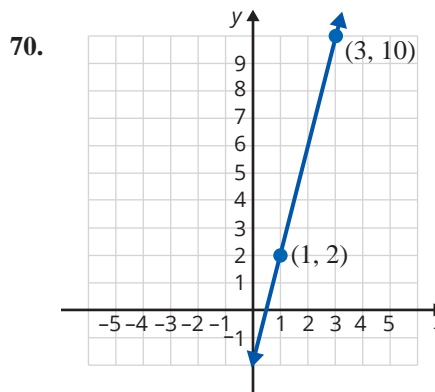
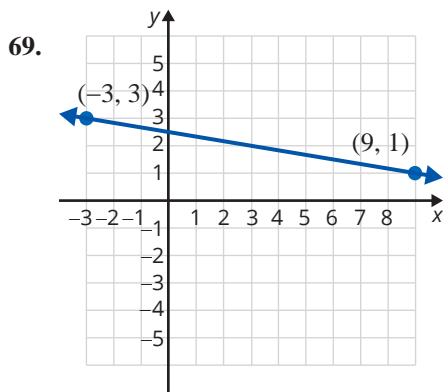
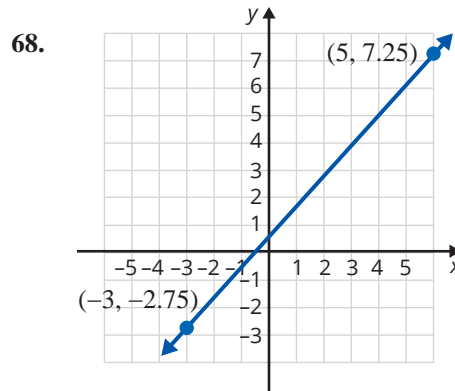
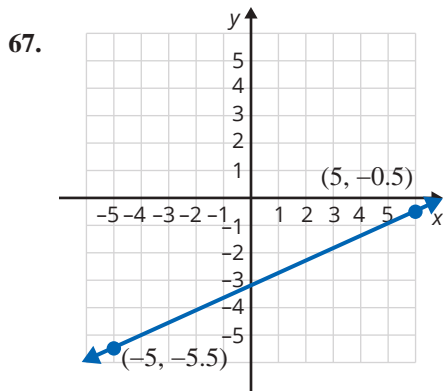

Points are said to be **collinear** if they lie on a straight line. If points are collinear, then the slope of the line through any two of them must be the same (because the line is the same line). Use this idea to determine whether the three points in each of the sets are collinear.

71. $\{(-1, 3), (0, 1), (5, -9)\}$

72. $\{(-2, -4), (0, 2), (3, 11)\}$

73. $\{(-2, 0), (0, 30), (1.5, 5.25)\}$

74. $\{(-1, -7), (1, 1), (2.5, 7)\}$

75. $\left\{\left(\frac{2}{3}, \frac{1}{2}\right), \left(0, \frac{5}{6}\right), \left(-\frac{3}{4}, \frac{29}{24}\right)\right\}$

76. $\left\{\left(\frac{3}{2}, -\frac{1}{3}\right), \left(0, \frac{1}{6}\right), \left(-\frac{1}{2}, \frac{3}{4}\right)\right\}$

Applications

Solve.

77. Find the slope of the ski slope.

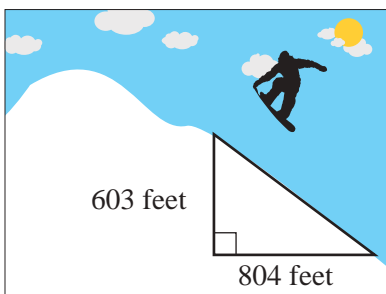

78. Find the slope of the road.

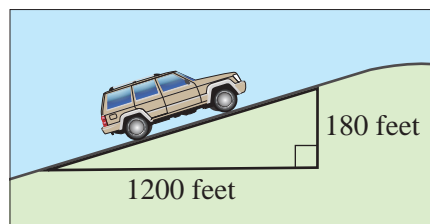

79. Find the slope of the roof of the skyscraper.

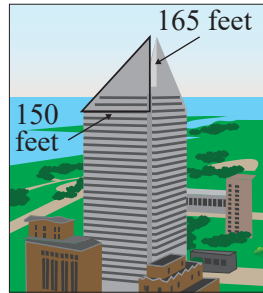

80. Find the slope of the larger sail on the sailboat.



81. A car travels from Charleston to Greenville. Its distance related to time traveled is given on the following graph. Find the average speed of the car in miles per hour from Columbia to Greenville.

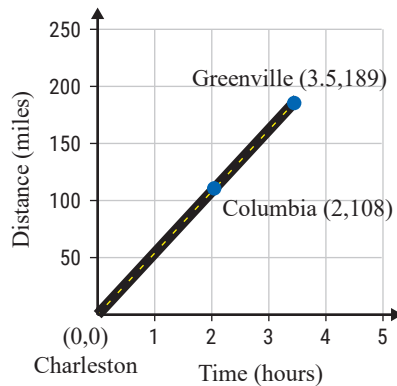

82. The attendance at Smithville's Spring Festival has been increasing steadily as shown in the graph. Find the average increase in attendees per year. How many people do you predict will attend the festival in 2026?

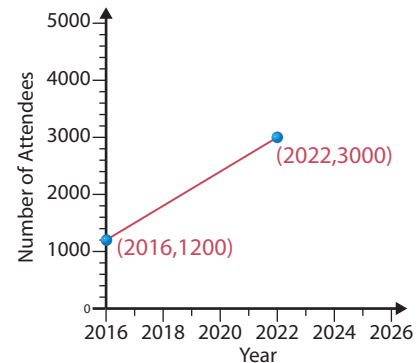

83. John bought his new car for \$35,000 in the year 2022. He knows that the value of his car has depreciated linearly. If the value of the car in 2025 was \$23,000, what was the annual rate of depreciation of his car? Show this information on a graph. (When graphing, use years as the x -coordinates and the corresponding values of the car as the y -coordinates.)
84. The number of people in the United States with cell phones was about 198 million in 2011 and about 232 million in 2016. If the growth in the usage of cell phones was linear, what was the approximate rate of growth per year from 2011 to 2016. Show this information on a graph. (When graphing, use years as the x -coordinates and the corresponding numbers of users as the y -coordinates.)¹

¹ Source: www.statista.com/statistics/231612/number-of-cell-phone-users-usa/

85. The Millennium Force roller coaster at Cedar Point in Sandusky, Ohio, has been voted the Best Steel Coaster by Golden Ticket eleven times since 2001. The Millennium Force is known for its steep slope on the first hill and speeds up to 93 miles per hour. The descent from the first hill starts at 310 feet above the ground and ends 10 feet above the ground. The descent runs approximately 53 feet. Find the slope of this hill to the nearest hundredth. (**Hint:** The slope is running downhill. Consider how that affects the slope.)

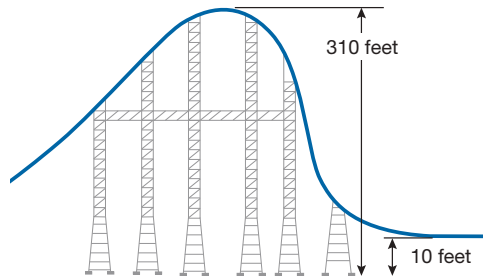

86.  The grade, or slope, of a road is commonly given as a percentage. The grade can be determined by multiplying the slope by 100. Calculate the slope of each road or track and then determine its grade. Round each percent to the nearest hundredth if necessary.
- A road increases in height 5 feet for every 120 feet of run.
 - The railway line with the steepest grade that does not run on a track system is the Lisbon tramway network in Portugal which has a section that increases 5 feet in height for every 37 feet of run.
 - A road on the Route des Crêtes (Route of the Ridges) in France has an elevation that increases in height 450 feet over 1500 feet.
87. Jared sells paintings at an open-air market. He starts his work day with \$30 and sells each painting for \$15. Jared wants to create a linear equation to model this situation where y is the amount of money Jared has at the end of the work day and x is the number of paintings sold.
- The slope, or rate of change, is the increase in the amount of money Jared makes when he sells a painting. Determine the value of the slope and list the units for both variables.
 - The y -coordinate of the y -intercept of this equation is the amount of money Jared has before he sells any paintings. What is the y -intercept?
 - Write a linear equation in slope-intercept form to model this situation using the answers from parts a. and b.
 - Graph the equation from part c.
 - Are there any solutions to the equation which do not make sense in the context of the problem? Explain why.
 - Use the graph to determine the amount of money Jared will have after selling 4 paintings.

88. The given table shows the estimated number of internet users from 2018 through 2022. The number of users for each year is shown in millions.
- Plot these points on a graph.
 - Connect the points with line segments.
 - Find the slope of each line segment.
 - Interpret each slope as a rate of change.

| Year | Internet users (in millions) |
|------|------------------------------|
| 2018 | 293 |
| 2019 | 312 |
| 2020 | 288 |
| 2021 | 299 |
| 2022 | 299 |

Source: www.statista.com/statistics/276445/number-of-internet-users-in-the-united-states

89. The following table shows the urban growth from 1850 to 2000 in New York, NY.

| Year | Population |
|------|------------|
| 1850 | 515,547 |
| 1900 | 3,437,202 |
| 1950 | 7,891,957 |
| 2000 | 8,008,278 |

Source: U.S. Census Bureau

- Plot these points on a graph.
- Connect the points with line segments.
- Find the slope of each line segment.
- Interpret each slope as a rate of change.

90. The following graph shows the number of female active duty military personnel over a span from 1945 to 2016. The number of women listed includes both officers and enlisted personnel from the Army, the Navy, the Marine Corps, and the Air Force.

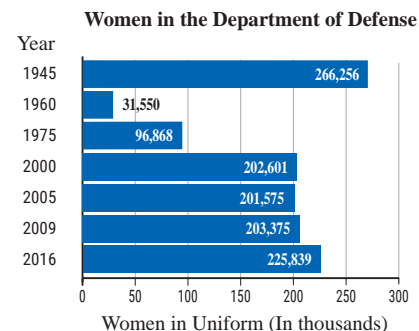

Source: U.S. Dept. of Defense

- Plot these points on a graph.
- Connect the points with line segments.
- Find the slope of each line segment.
- Interpret each slope as a rate of change.

91. The following graph shows the rates of marriage per 1000 people in the US over a span from 1940 to 2020.

- Plot these points on a graph.
- Connect the points with line segments.
- Find the slope of each line segment.
- Interpret each slope as a rate of change.

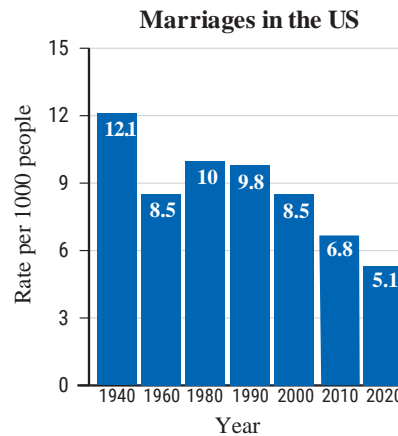

Source: U.S. National Center for Health Statistics

Writing & Thinking

- Explain in your own words why the slope of a horizontal line must be 0.
 - Explain in your own words why the slope of a vertical line must be undefined.
- Describe the graph of the line $y = 0$.
 - Describe the graph of the line $x = 0$.
- In the formula $y = mx + b$, explain the meaning of m and the meaning of b .
- The slope of a road is called a **grade**. A steep grade is cause for truck drivers to have slow speed limits in mountains. What do you think that a “grade of 12%” means? Draw a picture of a right triangle that would indicate a grade of 12%.

Collaborative Learning

- The class should be divided into teams of 2 or 3 students. Each team will need access to a digital camera, a printer, and a ruler.
 - Take pictures of 8 things with a defined slope. (**Suggestions:** A roof, a stair railing, a beach umbrella, a crooked tree, etc. Be creative!)
 - Print each picture.
 - Use a ruler to draw a coordinate system on top of each picture. You will probably want to use increments of in. or cm, depending on the size of your picture.
 - Identify the line in each picture whose slope you are calculating and then use the coordinate systems you created to identify the coordinates of two points on each line.
 - Use the points you just found to calculate the slope of the line in each picture.
 - Share your findings with the class.

5.4 Exercises

Concept Check

Fill-in-the-Blank. Complete each sentence using information found in this section.

- Perpendicular lines have slopes that are _____ of each other.
- The point-slope form for an equation is _____.
- Parallel lines have the _____ slope.
- Lines represented by the equation $Ax + By = C$ are in _____ form.
- In the equation $y - y_1 = m(x - x_1)$, m represents the _____.
- _____ lines are of the form $x = a$.

True/False. Determine whether each statement is true or false. If a statement is false, explain how it can be changed so the statement will be true. (**Note:** There may be more than one acceptable change.)

- Given two perpendicular lines (neither of which have slope 0), we know that one has a positive slope and the other has a negative slope.
- If Line 2 is parallel to Line 3, then the slope of Line 2 equals the slope of Line 3.
- A line perpendicular to a horizontal line has a slope that is undefined.
- All pairs of lines are either parallel or perpendicular.

Practice

Find **a.** the slope, **b.** a point on the line, and **c.** the graph of the line for the following equations in point-slope form.

- | | | |
|---------------------------------|--------------------|----------------------------------|
| 1. $y - 1 = 2(x - 3)$ | 3. $y + 2 = -5(x)$ | 5. $y - 3 = -\frac{1}{4}(x + 2)$ |
| 2. $y - 4 = \frac{1}{2}(x - 1)$ | 4. $y = -(x + 8)$ | 6. $y + 6 = \frac{1}{3}(x - 7)$ |

Find an equation in standard form for the line passing through the given point with the given slope. Graph the line. See Examples 1 and 2.

- | | | |
|----------------------|-------------------------------------|---|
| 7. $(-2, 1); m = -2$ | 11. $(-3, 6); m = \frac{1}{2}$ | 14. $(-1, -1); m = -\frac{1}{4}$ |
| 8. $(3, 4); m = 3$ | 12. $(-3, -1);$ m is undefined | 15. $\left(-2, \frac{1}{3}\right); m = \frac{2}{3}$ |
| 9. $(5, -2); m = 0$ | 13. $(7, 10); m = \frac{3}{5}$ | 16. $\left(\frac{5}{2}, \frac{1}{2}\right); m = -\frac{4}{3}$ |
| 10. $(0, 0); m = -3$ | | |

Find an equation in slope-intercept form for the line passing through the two given points. See Example 3.

- | | |
|---|---|
| 17. $(-5, 2); (3, 6)$ | 22. $\left(\frac{5}{2}, 0\right); \left(2, -\frac{1}{3}\right)$ |
| 18. $(-3, 4); (2, 1)$ | 23. $(2, -5); (4, -5)$ |
| 19. $(-5, 1); (2, 0)$ | 24. $(0, 4); \left(1, \frac{1}{2}\right)$ |
| 20. $(-4, -4); (3, 1)$ | 25. $(-2, 6); (3, 1)$ |
| 21. $(0, 2); \left(1, \frac{3}{4}\right)$ | 26. $(8, 2); (0, 0)$ |

Find an equation in standard form for each line shown. See Example 4.

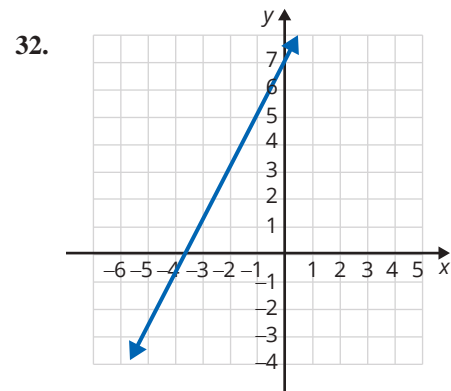
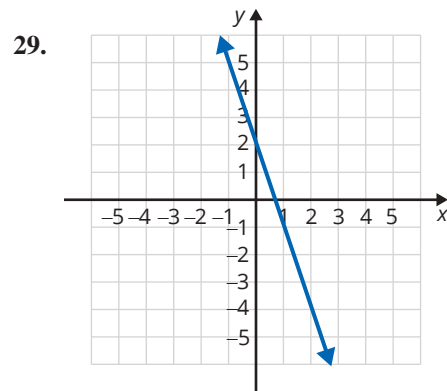
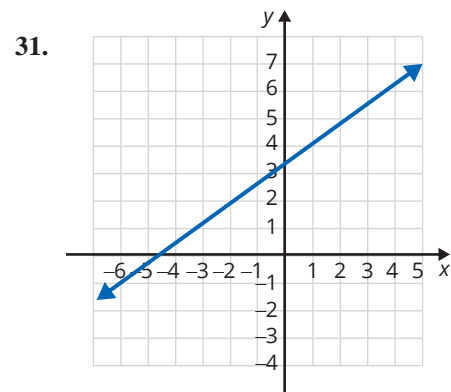
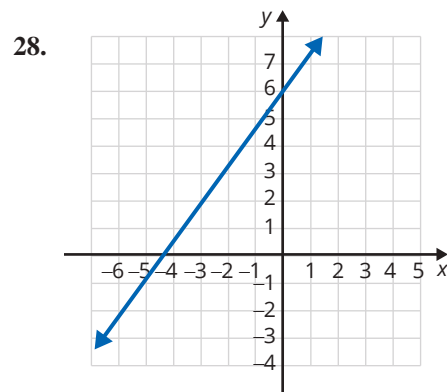
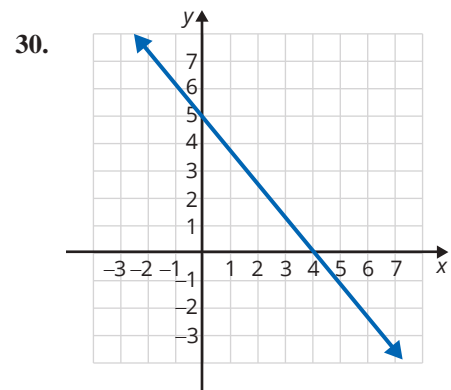
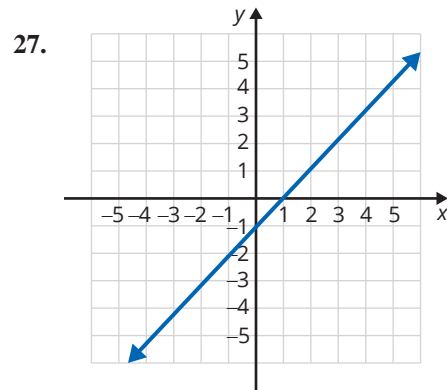

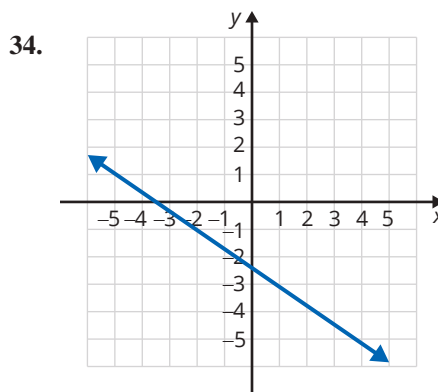
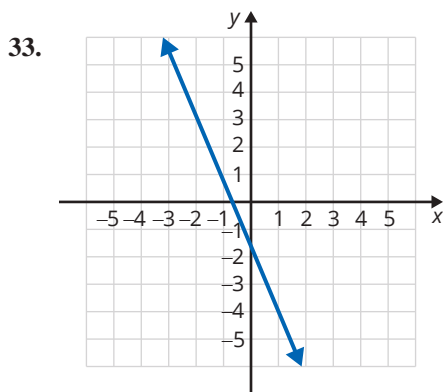

Find an equation in slope-intercept form that satisfies each set of conditions. See Examples 5 and 6.

35. Find an equation for the horizontal line through the point $(-2, 6)$.
36. Find an equation for the vertical line through the point $(-1, -4)$.
37. Write an equation for the line parallel to the x -axis and containing the point $(2, 7)$.
38. Find an equation for the line parallel to the y -axis and containing the point $(2, -4)$.
39. Find an equation for the line perpendicular to $x = 4$ and that passes through $(-1, 7)$.
40. Find an equation for the line parallel to the line $-6y = 1$ and containing the point $(-3, 2)$.
41. Write an equation for the line parallel to the line $2x - y = 4$ and containing the origin. Graph both lines.
42. Find an equation for the line parallel to $7x - 3y = 1$ and containing the point $(1, 0)$. Graph both lines.
43. Write an equation for the line parallel to $5x = 7 + y$ and through the point $(-1, -3)$. Graph both lines.
44. Write an equation for the line that contains the point $(2, 2)$ and is perpendicular to the line $4x + 3y = 4$. Graph both lines.
45. Find an equation for the line that passes through the point $(4, -1)$ and is perpendicular to the line $5x - 3y + 4 = 0$. Graph both lines.
46. Write an equation for the line that is perpendicular to $8 - 3x - 2y = 0$ and passes through the point $(-4, -2)$.
47. Write an equation for the line through the origin that is perpendicular to $3x - y = 4$.
48. Find an equation for the line that is perpendicular to $2x + y = 5$ and that passes through $(6, -1)$.
49. Write an equation for the line that is perpendicular to $2x - y = 7$ and has the same y -intercept as $x - 3y = 6$.
50. Find an equation for the line with the same y -intercept as $5x + 4y = 12$ and that is perpendicular to $3x - 2y = 4$.
51. Show that the points $A(-2, 4)$, $B(0, 0)$, $C(6, 3)$, and $D(4, 7)$ are the vertices of a rectangle. (Plot the points and show that opposite sides are parallel and that adjacent sides are perpendicular.)
52. Show that the points $A(0, -1)$, $B(3, -4)$, $C(6, 3)$, and $D(9, 0)$ are the vertices of a parallelogram. (Plot the points and show that opposite sides are parallel.)

Determine whether each pair of lines is **a.** parallel, **b.** perpendicular, or **c.** neither. Graph both lines. (**Hint:** Write the equations in slope-intercept form and then compare slopes.)

$$53. \begin{cases} y = -2x + 3 \\ y = -2x - 1 \end{cases}$$

$$54. \begin{cases} y = 3x + 2 \\ y = -\frac{1}{3}x + 6 \end{cases}$$

$$55. \begin{cases} 4x + y = 4 \\ x - 4y = 8 \end{cases}$$

$$56. \begin{cases} 2x + 3y = 5 \\ 3x + 2y = 10 \end{cases}$$

$$57. \begin{cases} 2x + 2y = 9 \\ 2x - y = 6 \end{cases}$$

$$58. \begin{cases} 3x - 4y = 16 \\ 4x + 3y = 15 \end{cases}$$

Applications

Solve.

59. The cost for an airline to fly from Raleigh, NC, to Nashville, TN, is \$5000. The airline charges \$100 for the one-way ticket from Raleigh to Nashville.
- Find an equation for the profit P made by the airline on this one-way flight if they sell t tickets.
 - Use the equation found in part a. to determine the number of tickets that must be sold for the airline to “break even;” that is, for the profit to be equal to 0?
60. A scrapbooking club offers a monthly sticker subscription that is \$9.95 for any selection of 100 stickers, then charges \$0.10 for each additional sticker over 100.
- Write an equation for the total bill, b , in a month in which you order s stickers (where s is at least 100).
 - Jenny’s bill last month was \$27.85. How many stickers did she order?
61. Betsy earns 10 hours of paid time off (PTO) per month and the accumulated hours rollover each month. Two months into the current year, she has accumulated a total of 80 hours of PTO. Let y be the number of PTO hours accumulated and x be the number of months.
- Graph the line that represents her projected PTO accumulation for the current calendar year if she does not use any PTO. (Graph should specify that x -axis is months and y -axis is hours of PTO.)
 - Write the equation in point-slope form that represents Betsy’s projected PTO accumulation.
62. The price p of a college textbook increases as the number of pages n increases. In fact, the price increases \$20 for every 100 pages that are added to the textbook.
- Assuming there are no “fixed” costs, find an equation for the price of a textbook in terms of the number of pages.
 - Use the equation found in part a. to approximate the price of a 560-page textbook.
63. A taxi charges a fare of \$5.00 plus \$0.25 per eighth of a mile for a ride.
- Find an equation for the fare f in terms of the number of miles m .
 - Use the equation found in part a. to determine the cost for a 15-mile ride.

64. Natalie invested some money in a simple interest savings fund. After 2 years, she earned \$120 in interest. After 5 years, she earned \$300 in interest.
- Write two ordered pairs from the information given where x represents the time in years and y represents the amount of interest earned.
 - Find the slope of the line which contains the two ordered pairs from part a.
 - Write the point-slope equation that models the situation.
 - Rewrite this equation in $y = mx + b$ form.
65. An archaeology crew finds the foundation of a house during a dig. The corners of the foundations are plotted on their grid map at the following points: $(1, 7)$, $(3, 2)$, $(9, 4)$, and $(7, 9)$.
- Plot the points on the coordinate plane.
 - Find the slope of each side of the foundation.
 - Are any of the sides parallel? If so, which sides?
 - Are any of the sides perpendicular to each other? If so, which sides?
 - Is the foundation in the form of a geometric shape? If so, which shape?

Writing & Thinking

66. Ramps for persons with disabilities are now built into most buildings and walkways. (If ramps are not present in a building, then there must be elevators.) What do you think that the slope of a ramp should be in order to be considered accessible? Look in your library or contact your local building permit office to find the recommended slope for such ramps.

Note

The standard window shows 96 pixels across the window and 64 pixels up and down the window. This gives a ratio of 3 to 2 and can give a slightly distorted view of the actual graph because the vertical pixels are squeezed into a smaller space. For Example 9c, the graphs of all three functions are in the standard window. Experiment by changing the window to a square window, say -9 to 9 for x and -6 to 6 for y . Then graph the functions and notice the slight differences (and better representation) in the appearances on the display.

- b. Since the graph of this function has two x -intercepts, we have shown the graph twice. Each graph shows the coordinates of a distinct x -intercept.

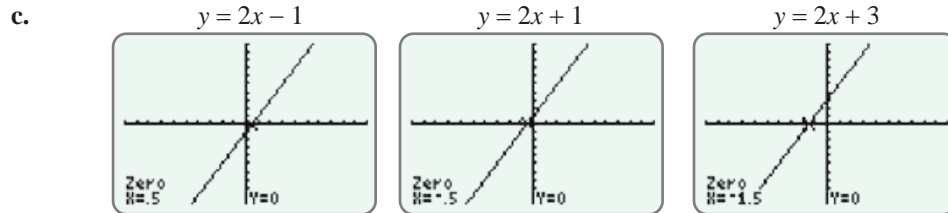
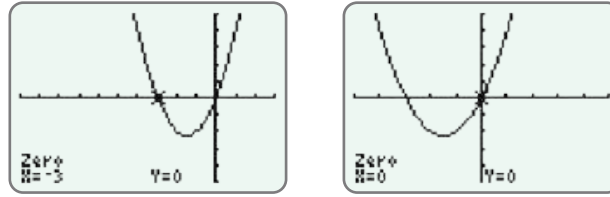

Now work margin exercise 9.

Margin Exercise Answers

1. a. $D = \{4, 7, 3\}$; b. $D = \{-2, -4, 0\}$; 2. a. $D = [-5, 6]$; b. $D = (-\infty, 3]$
 $R = \{5, 3, 6\}$ $R = \{3, -3, 0\}$ $R = [-5, 5]$ $R = (-\infty, \infty)$
3. a. not a function b. function 4. a. not a function; $D = \{-7, -3, 0, 2, 4, 5\}$
 $R = \{-2, 0, 2, 3, 6\}$
- b. function; $D = (-\infty, \infty)$ c. not a function; $D = [-5, 7]$ 5. $D = (-\infty, -3) \cup (-3, \infty)$
 $R = [-2, \infty)$ $R = [-1, 5]$ or $x \neq -3$
6. a. $g(3) = 7$ b. $g(-2) = -8$ c. $g(0) = -2$ 7. a. $f(1) = 4$ b. $f(0) = 5$ c. $f(-3) = -16$ 8. a. $f(4) = -5$
b. $f(-4) = -2$ c. $f(-2) = -1$

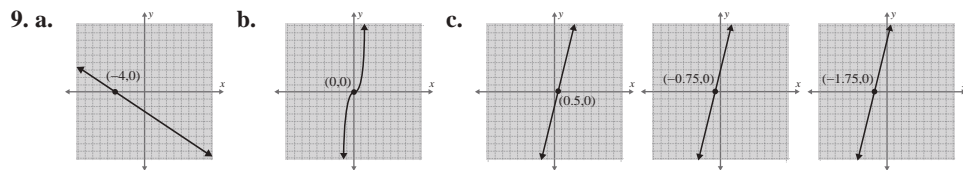

5.5 Exercises

Concept Check

Fill-in-the-Blank. Complete each sentence using information found in this section.

- The equation $y = mx + b$ represents a linear function and $f(x) = mx + b$ is the same equation written in _____ notation.
- The _____ line test can be used to determine if a relation is a function.
- The set of all first coordinates in a relation is the _____, D .
- The set of all second coordinates in a relation is the _____, R .

5. In the graph of a relation, the x -axis is called the _____ axis.
6. In the graph of a relation, the y -axis is called the _____ axis.

True/False. Determine whether each statement is true or false. If a statement is false, explain how it can be changed so the statement will be true. (**Note:** There may be more than one acceptable change.)

7. If the domain of a linear function is not explicitly stated, the implied domain is the set of all values of x that produce real values for y .
8. A relation is a function in which each domain element has exactly one corresponding range element.
9. In a function, the range elements can have more than one corresponding domain element.
10. If $s = \{(1, -6), (3, 5), (4, 0), (1, 2)\}$, then s is a function.

Practice

List the sets of ordered pairs that correspond to the points. State the domain and range and indicate which of the relations are also functions. See Examples 1 through 3.

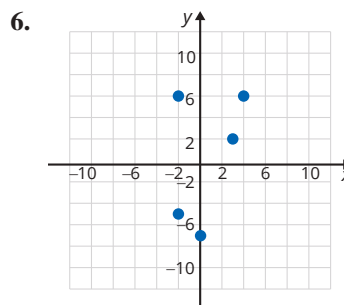
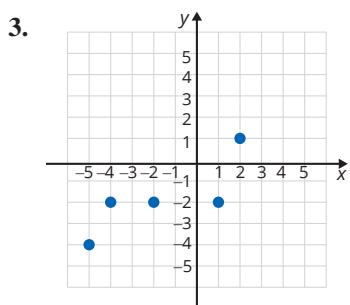
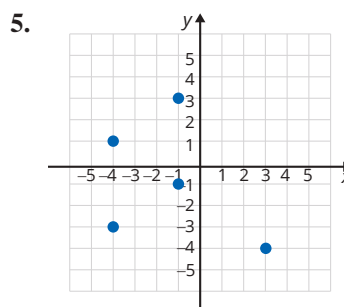
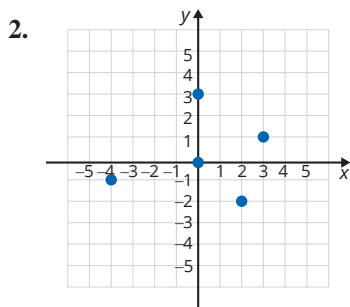
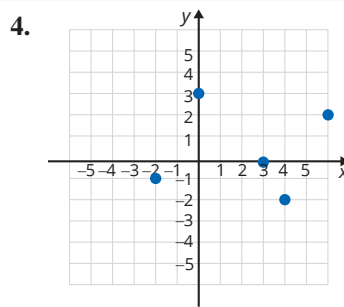
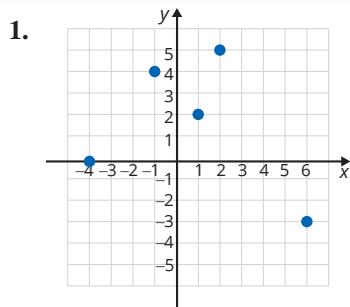

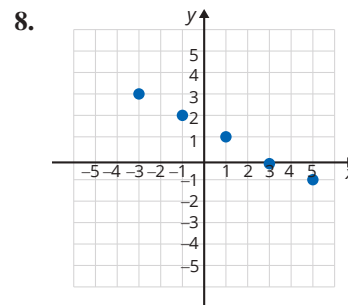
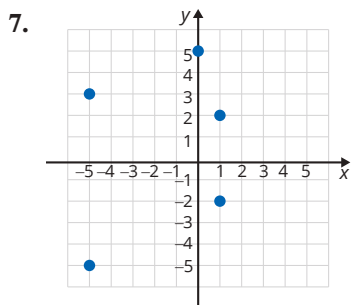

Graph the relations. State the domain and range and indicate which of the relations are functions. See Examples 1 through 3.

9. $f = \{(0, 0), (1, 6), (4, -2), (-3, 5), (2, -1)\}$

10. $h = \{(1, -5), (2, -3), (-1, -3), (0, 2), (4, 3)\}$

11. $g = \{(-4, 4), (-3, 4), (1, 4), (2, 4), (3, 4)\}$

12. $f = \{(-3, -3), (0, 1), (-2, 1), (3, 1), (5, 1)\}$

13. $s = \{(0, 2), (-1, 1), (2, 4), (3, 5), (-3, 5)\}$

14. $t = \{(-1, -4), (0, -3), (2, -1), (4, 1), (1, 1)\}$

15. $f = \{(-1, 4), (-1, 2), (-1, 0), (-1, 6), (-1, -2)\}$

16. $g = \{(0, 0), (-2, -5), (2, 0), (4, -6), (5, 2)\}$

Use the vertical line test to determine whether or not each graph represents a function. State the domain and range using interval notation. See Example 4.

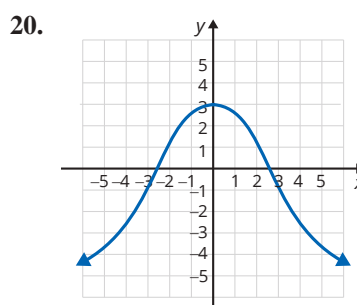
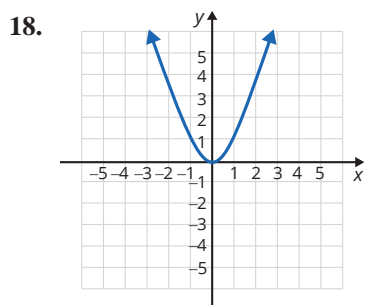
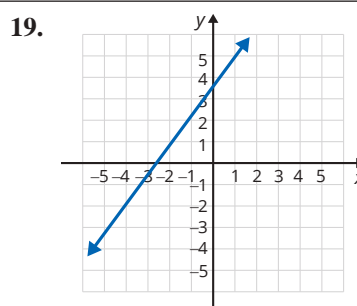
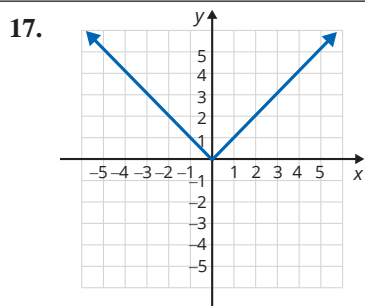

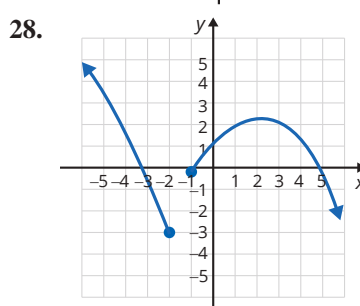
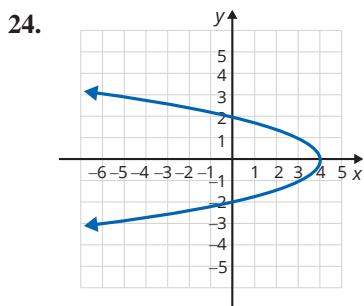
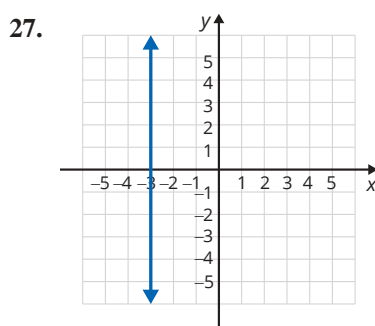
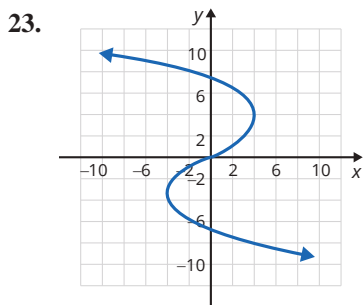
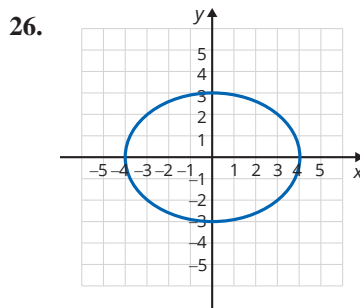
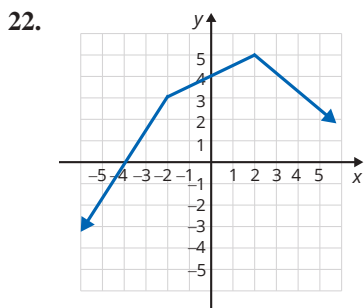
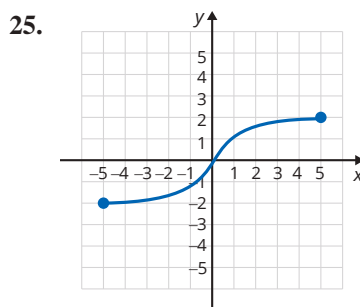
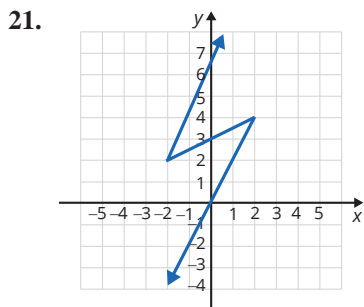

Express the function as a set of ordered pairs for the given equation and given domain. (**Hint:** Substitute each domain element for x and find the corresponding y -coordinate.)

29. $y = 3x + 1; D = \left\{-9, -\frac{1}{3}, 0, \frac{4}{3}, 2\right\}$

31. $y = 1 - 3x^2; D = \{-2, -1, 0, 1, 2\}$

30. $y = -\frac{3}{4}x + 2; D = \{-4, -2, 0, 3, 4\}$

32. $y = x^3 - 4x; D = \left\{-1, 0, \frac{1}{2}, 1, 2\right\}$

State the domains of the functions. See Example 5.

33. $y = -5x + 10$

35. $g(x) = \frac{8}{x}$

34. $2x + y = 14$

36. $h(x) = \frac{7}{3x}$

37. $y = \frac{13x^2 - 5x + 8}{x - 3}$

38. $f(x) = \frac{35}{x - 6}$

Find the values of the functions as indicated. See Examples 6 and 7.

39. $f(x) = 3x - 10$

a. $f(2)$

b. $f(-2)$

c. $f(0)$

40. $g(x) = -4x + 7$

a. $g(-3)$

b. $g(6)$

c. $g(0)$

41. $G(x) = x^2 + 5x + 6$

a. $G(-2)$

b. $G(1)$

c. $G(5)$

42. $F(x) = 6x^2 - 10$

a. $F(0)$

b. $F(-4)$

c. $F(4)$

43. $h(x) = x^3 - 8x$

a. $h(-3)$

b. $h(0)$

c. $h(3)$

44. $P(x) = x^2 + 4x + 4$

a. $P(-2)$

b. $P(10)$

c. $P(-5)$

Using the graph of $f(x)$, find each value. See Example 8.

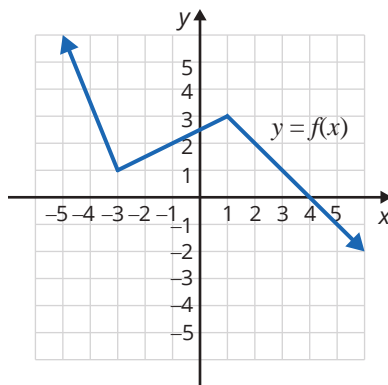

45. $f(1)$

47. $f(4)$

46. $f(-3)$

48. $f(-1)$

 Use a graphing calculator to graph the functions. Use the CALC features to find x-intercepts, if any. (The value of y will be 0 at those points.) For absolute value functions, select the MATH menu, then the NUM menu, and then abs (. Remember to press) after entering the absolute value. See Example 9.

49. $y = 6$

52. $y = -2x + 3$

50. $y = 4x$

53. $y = x^2 - 4x$

51. $y = x + 5$

54. $y = 1 + 2x - x^2$

55. $y = -|3x|$

56. $y = |x+2|$

57. $y = |x^2 - 3x|$

58. $y = 2x^3 - 5x^2 + 1$

59. $y = -x^3 + 3x - 1$

60. $y = x^4 - 10x^2 + 9$

 Use the CALC features of the calculator to find the coordinates of any points of intersection of the graphs. (**Hint:** The intersect item on the CALC menu will help in finding the point (or points) of intersection of two functions, if there is one.) In the Y = menu use both Y1 = and Y2 = to be able to graph both functions at the same time.

61. $y = 3x + 2$
 $y = 4 - x$

63. $y = 2x - 1$
 $y = x^2$

62. $y = 2 - x$
 $y = x$

64. $y = x + 3$
 $y = -x^2 + x + 7$

The calculator display shows an incorrect graph for the corresponding equation. Explain how you know, by just looking at the graph, that a mistake has been made.

65. $y = 2x + 5$

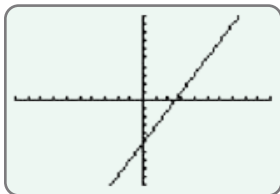

68. $y = -4x$

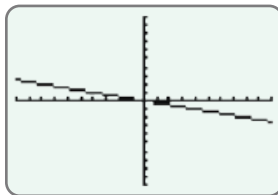

66. $y = -3x + 4$

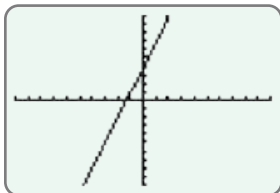

69. $y = -\frac{1}{3}x$

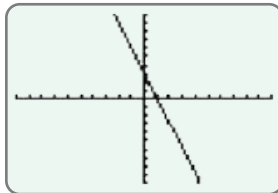

67. $y = \frac{2}{3}x - 2$

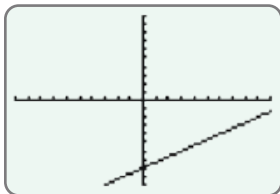

Applications

Solve.

- 70.** A nurse hangs a 1000-milliliter IV bag that is set to drip at 120 milliliters per hour. Create a model of this situation to represent the amount of IV solution left in the bag after x hours.
- The y -intercept is the amount of IV solution in the bag initially (time = 0). What is the y -intercept?
 - The slope is equal to the rate that the IV solution is dispensed per hour. What is the slope? (**Hint:** Consider whether the amount of IV solution in the bag is increasing or decreasing and how this would affect the slope.)
 - Write an equation in slope-intercept form to model this situation.
 - Write the equation from part c. using function notation.
 - State the domain and range of the function.
 - State any additional restrictions that should be made on the domain for it to make sense in the context of this problem.
 - How much IV solution is left in the bag after 5 hours?
- 71.** Ariella is a full-time sales associate at a clothing store. She earns a weekly salary of \$250 and earns 15% commission on all of her sales. Create a model of this situation to represent the amount of money Ariella makes after x dollars in sales.
- What is the y -intercept and what does the y -coordinate of the y -intercept represent?
 - What is the slope and what does this value represent?
 - Write an equation in slope-intercept form to model this situation using the answers from parts a. and b.
 - Write the equation from part c. using function notation.
 - State the domain and range of the function.
 - State any additional restrictions that should be made on the domain for it to make sense in the context of this problem.
 - How much will Ariella make if she sells \$5000 worth of merchandise?

Writing & Thinking

- 72.**  Enter a variety of functions in your calculator, investigate your findings, and report these to your class. Certainly, interesting discussions will follow!

5.6 Exercises

Concept Check

Fill-in-the-Blank. Complete each sentence using information found in this section.

- To determine which half-plane is a solution of a linear inequality (and therefore should be shaded), _____ any point clearly on one side of the boundary line.
- If a point is tested on one side of the boundary line and it _____ the inequality, shade that side of the boundary line. The shaded region is the solution set.
- If a boundary line is not included in the solution set, the solution is a/an _____ half-plane.
- A straight line that separates two half-planes is called a/an _____ line.
- If a boundary line is part of the solution set, the graph of the solution set is a/an _____ half-plane.
- The boundary line should be _____ if the inequality is $<$ or $>$.

True/False. Determine whether each statement is true or false. If a statement is false, explain how it can be changed so the statement will be true. (**Note:** There may be more than one acceptable change.)

- A solid boundary line indicates that the points on that line are included in the solution.
- If the solution set is an open half-plane, then the boundary line is included in the solution.
- The boundary line is solid when the inequality uses a $<$ or $>$ symbol.
- The slope of an inequality is used to determine whether the boundary line is included in the solution.

Practice

Graph the solution set of each of the linear inequalities. See Examples 1 through 4.

- | | | | |
|-------------------|---------------------|--------------------|-------------------------------|
| 1. $x + y \leq 7$ | 9. $x - 2y > 8$ | 17. $x + 4 \geq 0$ | 25. $x + 3y < 7$ |
| 2. $x - y > -2$ | 10. $x + 3y \leq 3$ | 18. $x - 5 \leq 0$ | 26. $3x + 4y > 11$ |
| 3. $x - y > 4$ | 11. $4x + y \geq 2$ | 19. $y \geq -2$ | 27. $\frac{1}{2}x - y > 1$ |
| 4. $x + y \leq 6$ | 12. $5x - y < 4$ | 20. $y + 3 < 0$ | 28. $\frac{1}{3}x + y \geq 3$ |
| 5. $y < 4x$ | 13. $y \leq 5 - 3x$ | 21. $4x < -3y + 9$ | 29. $\frac{2}{3}x + y \geq 4$ |
| 6. $y < -2x$ | 14. $y \geq 8 - 2x$ | 22. $3x < 2y - 4$ | 30. $2x - \frac{4}{3}y > 8$ |
| 7. $y \geq -3x$ | 15. $2y - x \leq 0$ | 23. $3y > 4x + 6$ | |
| 8. $y > x$ | 16. $x + y > 0$ | 24. $5x < 2y - 6$ | |

 Use a graphing calculator to graph each of the linear inequalities. See Examples 5 and 6.

- | | | |
|------------------------|---------------------|-----------------------|
| 31. $y > \frac{1}{2}x$ | 35. $y \geq -3$ | 39. $3x + 2y \geq 12$ |
| 32. $2x \geq -6y$ | 36. $y \leq -4$ | 40. $3x - 4y > 15$ |
| 33. $x - y \leq 5$ | 37. $2x + y \leq 6$ | |
| 34. $x + 2y > 8$ | 38. $x - 3y \geq 9$ | |

Applications

Solve.

41. The grade for a 1-credit-hour survey class is based on an exam and a project, which are worth a maximum of 50 points each. The sum of the two scores must be at least 75 points for a student to earn a passing grade.
- Let the amount of points earned on the exam be represented by the variable x and the amount of points earned on the project be represented by the variable y . Create a linear inequality to describe the solution set for a passing grade.
 - Graph the linear inequality from part a.
 - A student earns 45 points on their final exam and 22 points on their project. Plot this point on the graph. Did this student earn a passing grade?
 - Are there any points in the solution set that do not make sense for this situation?
42. A fail-safe is installed on a device with two electrical inputs. If the sum of the inputs is greater than 250 kilowatts, the fail-safe will activate and cause the machine to switch off.
- Let one electrical input be represented by the variable x and the other be represented by the variable y . Create a linear inequality to describe the values that will activate the fail-safe.
 - Graph the linear inequality.
 - The device has electrical inputs of 95 kilowatts and 145 kilowatts. Plot this point on the graph. Will the fail-safe activate and switch off the device? Explain why.
43.  Janessa has been trying to live a healthier life, so she bought a wrist fitness tracker. At the end of the first week, she connected it to the computer to download the data. The line, given by $m = \frac{3}{10}d + 2$, best represents her first week's data, where m represents miles walked in a day and d represents the day number (for example, on day 1, $d = 1$). The given graph is meant to represent the best fit line for the data taken once a day at the same time each day.
- Fill out the following table using $m = \frac{3}{10}d + 2$, where the input is the day number.

| | | | | | | | |
|-------------|---|---|---|---|---|---|---|
| Domain, d | 1 | 2 | 3 | 4 | 5 | 6 | 7 |
| Range, m | | | | | | | |

- Assuming the best fit line continues, how many miles would you expect Janessa to walk by the end of the second week (day 14)? Round your answer to the nearest tenth.

Writing & Thinking

44. Explain in your own words how to test to determine which side of the graph of an inequality should be shaded.
45. Describe the difference between a closed and an open half-plane.

Margin Exercise Answers

1. $6 - 12 = -6$ True statement; $18 + 8 = 26$ True statement 2. $2 = -6 + 8$ True statement; $2 = 9 - 8$

False statement 3.

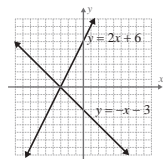

$(-3, 0)$

4.

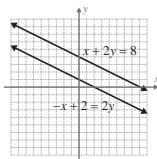

No solution

5.

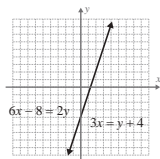

$(x, 3x - 4)$

6.

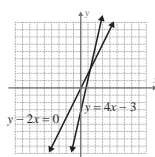

$(\frac{3}{2}, 3)$

7.

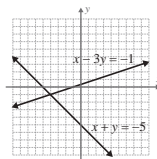

$(-4, -1)$

6.1 Exercises

Concept Check

Fill-in-the-Blank. Complete each sentence using information found in this section.

1. A system of equations is also called a set of _____ equations.
2. When solving a system of two linear equations, the goal is to find ordered pairs that satisfy _____ equations.
3. To solve a system of linear equations by graphing, you should graph both equations on the _____ set of axes.
4. A dependent system has _____ solution(s).
5. A consistent system has exactly ____ solution(s).
6. An inconsistent system has ____ solution(s).

True/False. Determine whether each statement is true or false. If a statement is false, explain how it can be changed so the statement will be true. (**Note:** There may be more than one acceptable change.)

7. To check a solution, substitute it into one of the equations. If the solution satisfies one equation it will satisfy all of the equations.
8. A system of equations with graphs that are parallel lines has exactly one solution.
9. A system of equations with graphs that intersect at one point has exactly one solution.
10. A system of equations with graphs that are the same line has infinitely many solutions.

Practice

Determine which of the given points, if any, lie on both of the lines in the systems of equations by substituting each point into both equations. See Examples 1 and 2.

$$1. \begin{cases} x - y = 6 \\ 2x + y = 0 \end{cases}$$

- a. (1, -2)
- b. (4, -2)
- c. (2, -4)
- d. (-1, 2)

$$2. \begin{cases} x + 3y = 5 \\ 3y = 4 - x \end{cases}$$

- a. (2, 1)
- b. (2, -2)
- c. (-1, 2)
- d. (4, 0)

$$3. \begin{cases} 2x + 4y - 6 = 0 \\ 3x + 6y - 9 = 0 \end{cases}$$

- a. (1, 1)
- b. (2, 0)
- c. $\left(0, \frac{3}{2}\right)$
- d. (-1, 3)

$$4. \begin{cases} 5x - 2y - 5 = 0 \\ 5x = -3y \end{cases}$$

- a. (1, 0)
- b. $\left(\frac{3}{5}, -1\right)$
- c. (0, 0)
- d. (1, 4)

The graphs of the lines represented by each system of equations are given. Determine the solution of the system by looking at the graph. Check your solution by substituting into both equations. See Example 3.

$$5. \begin{cases} x + 2y = 4 \\ x - y = -2 \end{cases}$$

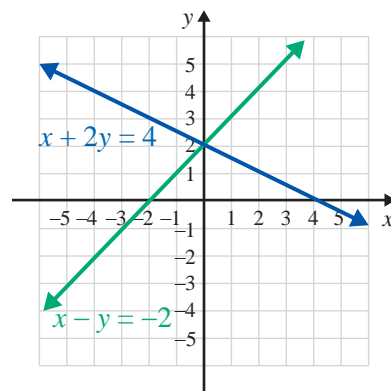

$$6. \begin{cases} x + 2y = 1 \\ 2x + y = -1 \end{cases}$$

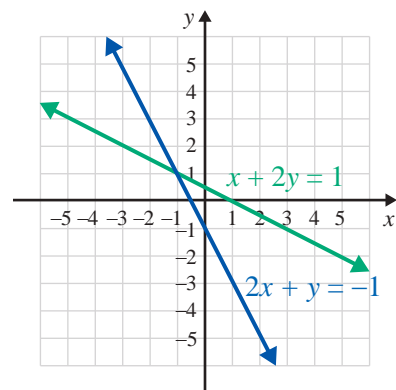

$$7. \begin{cases} 2x - y = 6 \\ 3x + y = 14 \end{cases}$$

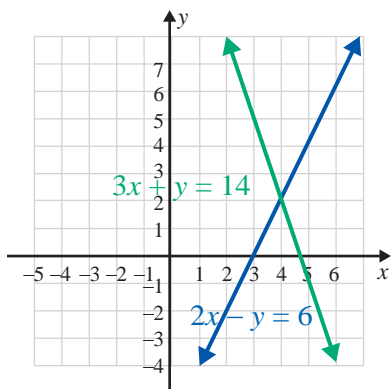

$$8. \begin{cases} x - y = 4 \\ 3x - y = 6 \end{cases}$$

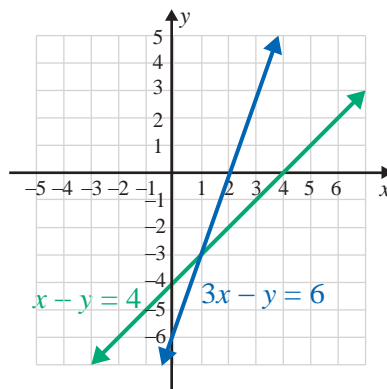

Show that each system of equations is inconsistent by determining the slope of each line and the y-intercept. (That is, show that the lines are parallel and do not intersect.) See Example 4.

$$9. \begin{cases} 2x + y = 3 \\ 4x + 2y = 5 \end{cases}$$

$$11. \begin{cases} y = \frac{1}{2}x + 3 \\ x - 2y = 1 \end{cases}$$

$$10. \begin{cases} 3x - 5y = 1 \\ 6x - 10y = 4 \end{cases}$$

$$12. \begin{cases} 3x - y = 8 \\ x - \frac{1}{3}y = 2 \end{cases}$$

Solve each system of equations by graphing. Then, state whether the system is consistent or inconsistent and whether the equations are dependent or independent. See Examples 3 through 6.

$$13. \begin{cases} y = x + 1 \\ y + x = -5 \end{cases}$$

$$17. \begin{cases} x + y - 5 = 0 \\ x = 5 - y \end{cases}$$

$$14. \begin{cases} y = 2x + 5 \\ 4x - 2y = 7 \end{cases}$$

$$18. \begin{cases} y = 4x - 3 \\ x = 2y - 8 \end{cases}$$

$$15. \begin{cases} 2x - y = 4 \\ 3x + y = 6 \end{cases}$$

$$19. \begin{cases} 3x - y = 6 \\ y = 3x \end{cases}$$

$$16. \begin{cases} 2x + 3y = 6 \\ 4x + 6y = 12 \end{cases}$$

$$20. \begin{cases} y = 2x \\ 2x + y = 4 \end{cases}$$

Solve each system of equations by graphing. See Examples 3 through 6.

$$21. \begin{cases} x - y = 5 \\ x = -3 \end{cases}$$

$$25. \begin{cases} 5x - 4y = 5 \\ 8y = 10x - 10 \end{cases}$$

$$22. \begin{cases} x - 2y = 4 \\ x = 4 \end{cases}$$

$$26. \begin{cases} 2x + y = 0 \\ 4x + 2y = -8 \end{cases}$$

$$23. \begin{cases} x + 2y = 8 \\ 3x - 2y = 0 \end{cases}$$

$$27. \begin{cases} 4x + 3y + 7 = 0 \\ 5x - 2y + 3 = 0 \end{cases}$$

$$24. \begin{cases} x + y = 8 \\ 5y = 2x + 5 \end{cases}$$

$$28. \begin{cases} 4x - 2y = 10 \\ -6x + 3y = -15 \end{cases}$$

29.
$$\begin{cases} x = 5 \\ y = -1 \end{cases}$$

30.
$$\begin{cases} y = 7 \\ x = 8 \end{cases}$$

31.
$$\begin{cases} \frac{1}{2}x + 2y = 7 \\ 2x = 4 - 8y \end{cases}$$

32.
$$\begin{cases} 4x + y = 6 \\ 2x + \frac{1}{2}y = 3 \end{cases}$$

33.
$$\begin{cases} 7x - 2y = 1 \\ y = 3 \end{cases}$$

34.
$$\begin{cases} x = 1.5 \\ x - 3y = 9 \end{cases}$$

35.
$$\begin{cases} y = \frac{1}{2}x + 2 \\ x - 2y + 4 = 0 \end{cases}$$

36.
$$\begin{cases} 2x - 5y = 6 \\ y = \frac{2}{5}x + 1 \end{cases}$$

37.
$$\begin{cases} 2x + 3y = 5 \\ 3x - 2y = 1 \end{cases}$$

38.
$$\begin{cases} \frac{2}{3}x + y = 2 \\ x - 4y = 3 \end{cases}$$

39.
$$\begin{cases} x - y = 4 \\ 2y = 2x - 4 \end{cases}$$

40.
$$\begin{cases} x + y = 4 \\ 2x - 3y = 3 \end{cases}$$

41.
$$\begin{cases} \frac{1}{2}x + \frac{1}{3}y = \frac{1}{6} \\ \frac{1}{4}x + \frac{1}{4}y = 0 \end{cases}$$

42.
$$\begin{cases} \frac{1}{4}x - y = \frac{13}{4} \\ \frac{1}{3}x + \frac{1}{6}y = -\frac{1}{6} \end{cases}$$

 Use a graphing calculator's intersect function to solve each system of equations. If necessary, round values to the nearest ten-thousandth. (Remember to solve each equation for y and then enter them as Y1 and Y2 in the $\boxed{Y=}$ menu.) See Example 7.

43.
$$\begin{cases} x + 2y = 9 \\ x - 2y = -7 \end{cases}$$

47.
$$\begin{cases} y = -3 \\ 2x + y = 0 \end{cases}$$

44.
$$\begin{cases} x - 3y = 0 \\ 2x + y = 7 \end{cases}$$

48.
$$\begin{cases} 2x - 3y = 1.25 \\ x + 2y = 5 \end{cases}$$

45.
$$\begin{cases} y = 2 \\ 2x - 3y = -3 \end{cases}$$

49.
$$\begin{cases} x + y = 3.5 \\ -2x + 5y = 7.7 \end{cases}$$

46.
$$\begin{cases} 2x - 3y = 0 \\ 3x + 3y = \frac{5}{2} \end{cases}$$

50.
$$\begin{cases} 4x + y = -0.5 \\ x + 2y = -8 \end{cases}$$

Applications

Each of the following applications has been modeled using a system of equations. Solve the system graphically.

51. The sum of two numbers is 25 and their difference is 15. What are the two numbers? Let x be one number and y be the other number.

The corresponding modeling system is
$$\begin{cases} x + y = 25 \\ x - y = 15 \end{cases}$$

52. The perimeter of a rectangle is 50 m and the length is 5 m longer than the width. Find the dimensions of the rectangle.

Let x be the length and y be the width.

The corresponding modeling system is
$$\begin{cases} 2x + 2y = 50 \\ x - y = 5 \end{cases}$$

53. OSHA recommends that swimming pool owners clean their pool decks with a solvent composed of a 12% chlorine solution and a 3% chlorine solution. Fifteen gallons of the solvent consists of 6% chlorine. How much of each of the mixing solutions were used?

Let x be the number of gallons of the 12% solution and y be the number of gallons of the 3% solution.

The corresponding modeling system is
$$\begin{cases} x + y = 15 \\ 0.12x + 0.03y = 0.06(15) \end{cases}$$

54. A student bought a calculator and a textbook for a course in algebra. He told his friend that the total cost was \$170 (without tax) and that the calculator cost \$20 more than twice the cost of the textbook. What was the cost of each item?

Let x be the cost of the calculator and y be the cost of the textbook.

The corresponding modeling system is
$$\begin{cases} x + y = 170 \\ x = 2y + 20 \end{cases}$$

55.  Felix is trying to decide between two job offers. Company A is offering \$15 per hour with a \$500 signing bonus and Company B is offering \$18 per hour with a \$100 signing bonus. Graph the system of linear equations to estimate how many hours he must work to make Company B the best financial choice. Round up to the nearest hour.

The corresponding modeling system is
$$\begin{cases} y = 15x + 500 \\ y = 18x + 100 \end{cases}$$

56. Silas is comparing two credit card offers. Credit Card A has no annual fee and offers 1.5% cash back on purchases. Credit Card B has a \$95 annual fee and offers 6% back on purchases. Let x be the amount spent and y be the amount of cash back, minus annual fees.

The corresponding modeling system is
$$\begin{cases} y = 0.015x \\ y = 0.06x - 95 \end{cases}$$

Find the ordered pair that represents the amount Silas needs to spend to earn the same amount of cash back minus his annual fees, and the amount of cash back he earns after spending that amount.

57. Mackenzie plans to join a gym and wants to decide between the two gyms that are close to her home, Fit4Life and Workout Nation. At Fit4Life, she would pay a \$20 per month membership fee and \$10 per class. At Workout Nation, she would pay a \$45 per month membership fee and \$5 per class. Mackenzie wants to determine how many classes she would have to take per month for both gyms to have the same cost.
- Write two equations to represent the situation. Use the variable y to represent the total cost per month and the variable x to represent the number of classes.
 - Graph the two equations on the same coordinate plane.
 - Find the point of intersection.
 - What does the point of intersection mean? Write a complete sentence.
 - If Mackenzie plans to take 10 classes per month, which gym would be the better deal?

- 58.** You are planning a vacation and would like to spend your money wisely. You decide to fly to your destination and then rent a car when you get there. Discount Car Rentals charges \$10 per day for the economy class car and \$0.10 per mile. Cars For Hire charges \$15 per day and \$0.05 per mile. You need to determine which car rental service offers the best deal.
- Write two equations to represent the situation. Use the variable y to represent the total cost per day and the variable x to represent the number of miles driven per day.
 - Graph the two equations on the same coordinate plane.
 - Find the point of intersection.
 - What does the point of intersection mean? Write a complete sentence.
 - You expect to drive at most 75 miles per day. Which car rental company should you rent the car from?

Writing & Thinking

- 59.** Explain, in your own words, why the answer to a consistent system of linear equations can be written as an ordered pair.

Completion Example Answers

6. $x = 3 - y; 3 - y;$

$$2(3 - y) - y = 12$$

$$6 - 2y - y = 12$$

$$6 - 3y = 12$$

$$-3y = 6$$

$$y = -2$$

$$x = 3 - (-2) = 5$$

The solution to the system is $(5, -2)$.**Margin Exercise Answers**

1. $(3, -5)$ 2. $(10, 1)$ 3. No solution 4. $(x, 1 + 2x)$ or $\left(\frac{y-1}{2}, y\right)$ 5. $(-3, 9)$ 6. $(-1, 3)$

6.2 Exercises

Concept Check

Fill-in-the-Blank. Complete each sentence using information found in this section.

- The first step when solving a system of equations using the method of substitution is to solve for one of the _____ in one of the equations.
- The second step is to substitute the resulting expression into the _____ expression.
- If the equation formed after substitution is never true, then the system has _____ solution(s).
- If the equation formed after substitution is always true, then the system has a/an _____ number of solutions.
- After solving the equation formed after substitution, the value of the variable is substituted into one of the original expressions to find the value of the other variable. This is known as _____.
- The solution should be checked in _____ equations.

True/False. Determine whether each statement is true or false. If a statement is false, explain how it can be changed so the statement will be true. (**Note:** There may be more than one acceptable change.)

- The method of substitution reduces the problem from one of solving two equations in two variables to solving one equation in one variable.
- The method of substitution is most often used when one of the equations is impossible to graph.
- The method of substitution is more accurate than the graphing method.
- When using the method of substitution, you should always solve the first equation for x .

Practice

Use the method of substitution to solve each system. See Examples 1 through 6.

1.
$$\begin{cases} x + y = 6 \\ y = 2x \end{cases}$$
2.
$$\begin{cases} 5x + 2y = 21 \\ x = y \end{cases}$$
3.
$$\begin{cases} 3x - 7 = y \\ 2y = 6x - 14 \end{cases}$$
4.
$$\begin{cases} y = 3x + 4 \\ 2y = 3x + 5 \end{cases}$$
5.
$$\begin{cases} x = 3y \\ 3y - 2x = 6 \end{cases}$$
6.
$$\begin{cases} 4x = y \\ 4x - y = 7 \end{cases}$$
7.
$$\begin{cases} x - 5y + 1 = 0 \\ x = 7 - 3y \end{cases}$$
8.
$$\begin{cases} 2x + 5y = 15 \\ x = y - 3 \end{cases}$$
9.
$$\begin{cases} 7x + y = 9 \\ y = 4 - 7x \end{cases}$$
10.
$$\begin{cases} 3y + 5x = 5 \\ y = 3 - 2x \end{cases}$$
11.
$$\begin{cases} 3x - y = 7 \\ x + y = 5 \end{cases}$$
12.
$$\begin{cases} 4x - 2y = 5 \\ y = 2x + 3 \end{cases}$$
13.
$$\begin{cases} 3x + 5y = -13 \\ y = 3 - 2x \end{cases}$$
14.
$$\begin{cases} 15x + 5y = 20 \\ y = -3x + 4 \end{cases}$$
15.
$$\begin{cases} x - y = 5 \\ 2x + 3y = 0 \end{cases}$$
16.
$$\begin{cases} 4x = 8 \\ 3x + y = 8 \end{cases}$$
17.
$$\begin{cases} 2y = 5 \\ 3x - 4y = -4 \end{cases}$$
18.
$$\begin{cases} x + y = 8 \\ 3x + 2y = 8 \end{cases}$$
19.
$$\begin{cases} y = 2x - 5 \\ 2x + y = -3 \end{cases}$$
20.
$$\begin{cases} 2x + 3y = 5 \\ x - 6y = 0 \end{cases}$$
21.
$$\begin{cases} x + 5y = 1 \\ x - 3y = 5 \end{cases}$$
22.
$$\begin{cases} 3x + 8y = -2 \\ x + 2y = -1 \end{cases}$$
23.
$$\begin{cases} 9x + 3y = 6 \\ 3x = 2 - y \end{cases}$$
24.
$$\begin{cases} 5x + 2y = -10 \\ 10x = -3 - 4y \end{cases}$$
25.
$$\begin{cases} x - 2y = -4 \\ 3x + y = -5 \end{cases}$$
26.
$$\begin{cases} x + 4y = 3 \\ 3x - 4y = 7 \end{cases}$$
27.
$$\begin{cases} 3x - y = -1 \\ 7x - 4y = 0 \end{cases}$$
28.
$$\begin{cases} x + 5y = -1 \\ 2x + 7y = 1 \end{cases}$$
29.
$$\begin{cases} x + 3y = 5 \\ 3x + 2y = 7 \end{cases}$$
30.
$$\begin{cases} 3x - 4y - 39 = 0 \\ 2x - y - 13 = 0 \end{cases}$$
31.
$$\begin{cases} \frac{1}{4}x - \frac{3}{2}y = -5 \\ -x + 6y = 20 \end{cases}$$
32.
$$\begin{cases} -\frac{4}{3}x + 2y = 7 \\ \frac{8}{3}x - 4y = -5 \end{cases}$$
33.
$$\begin{cases} 6x - y = 15 \\ 0.2x + 0.5y = 2.1 \end{cases}$$
34.
$$\begin{cases} x + 2y = 3 \\ 0.4x + y = 0.6 \end{cases}$$
35.
$$\begin{cases} 0.2x - 0.1y = 0 \\ y = x + 10 \end{cases}$$
36.
$$\begin{cases} 0.1x - 0.2y = 1.4 \\ 3x + y = 14 \end{cases}$$
37.
$$\begin{cases} 3x - 2y = 5 \\ y = 1.5x + 2 \end{cases}$$
38.
$$\begin{cases} x = 2y - 7.5 \\ 2x + 4y = -15 \end{cases}$$
39.
$$\begin{cases} \frac{1}{2}x + \frac{1}{3}y = 4 \\ 3x + 2y = 24 \end{cases}$$
40.
$$\begin{cases} \frac{1}{3}x + \frac{1}{7}y = 2 \\ 7x + 3y = 42 \end{cases}$$
41.
$$\begin{cases} \frac{x}{3} + \frac{y}{5} = 1 \\ x + 6y = 12 \end{cases}$$
42.
$$\begin{cases} \frac{x}{5} + \frac{y}{4} - 3 = 0 \\ \frac{x}{10} - \frac{y}{2} + 1 = 0 \end{cases}$$

Applications

Each of the following applications has been modeled using a system of equations. Use the method of substitution to solve each system. (**Note:** Some of these exercises were also given in Section 6.1. Check to see that you arrived at the same answers by both methods.)

43. The sum of two numbers is 25 and their difference is 15. What are the two numbers?

Let x be one number
and y be the other number.

The corresponding modeling system is
$$\begin{cases} x + y = 25 \\ x - y = 15 \end{cases}$$

44. The perimeter of a rectangle is 50 meters and the length is 5 meters longer than the width. Find the dimensions of the rectangle.

Let x be the length and y be the width.

The corresponding modeling system is
$$\begin{cases} 2x + 2y = 50 \\ x - y = 5 \end{cases}$$

45. OSHA recommends that swimming pool owners clean their pool decks with a solvent composed of a 12% chlorine solution and a 3% chlorine solution. Fifteen gallons of the solvent consists of 6% chlorine. How much of each of the mixing solutions were used?

Let x be the number of gallons of the 12% solution
and y be the number of gallons of the 3% solution.

The corresponding modeling system is

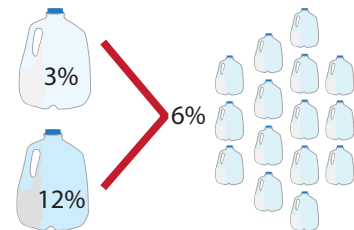
$$\begin{cases} x + y = 15 \\ 0.12x + 0.03y = 0.06(15) \end{cases}$$

46. A student bought a calculator and a textbook for a course in algebra. He told his friend that the total cost was \$170 (without tax) and that the calculator cost \$20 more than twice the cost of the textbook. What was the cost of each item?

Let x be the cost of the calculator
and y be the cost of the textbook.

The corresponding modeling system is

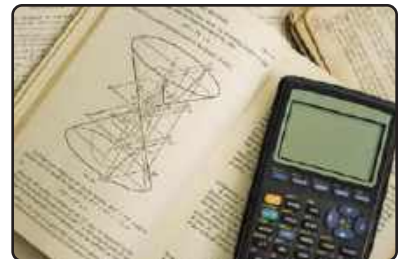
$$\begin{cases} x + y = 170 \\ x = 2y + 20 \end{cases}$$

47. A fitness center manager is trying to decide whether to charge an enrollment fee of \$25 with a monthly rate of \$50 or an enrollment fee of \$100 with a monthly rate of \$25. After how many months would it be more profitable for the manager to choose the lower enrollment fee and the higher monthly rate? Round up to the nearest month.

The corresponding modeling system is
$$\begin{cases} y = 50x + 25 \\ y = 25x + 100 \end{cases}$$

48. Connor is retiling the backsplash of his kitchen counter. He plans on using square tiles that measure 2 inches by 2 inches and rectangular tiles that measure 2 inches by 4 inches. The backsplash measures 6 inches by 60 inches. He wants to use an equal number of rectangular tiles and square tiles. How many of each tile will he need to buy?

- a. Find the area of each size tile and the area of the backsplash.

Completion Example Answers

5. $6x + 10y = -6$ Substitute $x = -1$; $3(-1) + 5y = -3$ The solution is $(-1, 0)$.

$$\begin{array}{r} 35x - 10y = -35 \\ \hline 41x = -41 \\ x = -1 \end{array} \qquad \begin{array}{r} -3 + 5y = -3 \\ 5y = 0 \\ y = 0 \end{array}$$

Margin Exercise Answers

1. $(-2, 5)$ 2. $(x, -2x + 5)$ or $\left(\frac{-1}{2}y + \frac{5}{2}, y\right)$ 3. No solution 4. $(5, 0.6)$ 5. $(2, -3)$
 6. $y = \frac{5}{2}x - 12$

6.3 Exercises

Concept Check

Fill-in-the-Blank. Complete each sentence using information found in this section.

- When using the method of addition, the objective is to _____ one of the variables so that a new equation is found with just one variable.
- The first step of the method of addition is to write one equation under the other so that the _____ are aligned vertically.
- To make it easier to align terms, the equations should be written in _____ form.
- Multiply the terms of one equation by a constant so that two like terms have _____ coefficients. You may need to multiply both equations by different constants.
- Next, add the two equations by _____ like terms and solve the resulting equation for the other variable.
- The addition method is particularly efficient if the _____ for one of the variables are opposites.

True/False. Determine whether each statement is true or false. If a statement is false, explain how it can be changed so the statement will be true. (**Note:** There may be more than one acceptable change.)

- When using the method of addition, the solution only needs to be checked in one of the original equations.
- It's possible for a system of equations to have no solutions.
- Both the addition method and the substitution method gives approximate solutions.
- The graphing method is helpful in "seeing" the geometric relationship between the lines and finding approximate solutions.

Practice

Use the method of addition to solve each system. See Examples 1 through 5.

$$1. \begin{cases} 8x - y = 29 \\ 2x + y = 11 \end{cases}$$

$$2. \begin{cases} x + 3y = 9 \\ x - 7y = -1 \end{cases}$$

$$3. \begin{cases} 3x + 2y = 0 \\ 5x - 2y = 8 \end{cases}$$

$$4. \begin{cases} 12x - 3y = 21 \\ 4x - y = 7 \end{cases}$$

$$5. \begin{cases} 2x + 2y = 5 \\ x + y = 3 \end{cases}$$

$$6. \begin{cases} 2x - y = 7 \\ x + y = 2 \end{cases}$$

$$7. \begin{cases} 3x + 3y = 9 \\ x + y = 3 \end{cases}$$

$$8. \begin{cases} 9x + 2y = -42 \\ 5x - 6y = -2 \end{cases}$$

$$9. \begin{cases} \frac{1}{2}x + y = -4 \\ 3x - 4y = 6 \end{cases}$$

$$10. \begin{cases} x + y = 1 \\ x - \frac{1}{3}y = \frac{11}{3} \end{cases}$$

$$11. \begin{cases} x + y = 12 \\ 0.05x + 0.25y = 1.6 \end{cases}$$

$$12. \begin{cases} x + 0.1y = 8 \\ 0.1x + 0.01y = 0.64 \end{cases}$$

Solve each system of linear equations. See Examples 1 through 5.

$$13. \begin{cases} x = 11 + 2y \\ 2x - 3y = 17 \end{cases}$$

$$14. \begin{cases} 6x - 3y = 6 \\ y = 2x - 2 \end{cases}$$

$$15. \begin{cases} x - 2y = 4 \\ y = \frac{1}{2}x - 2 \end{cases}$$

$$16. \begin{cases} 2x + y = 3 \\ 4x + 2y = 7 \end{cases}$$

$$17. \begin{cases} x = 3y + 4 \\ y = 6 - 2x \end{cases}$$

$$18. \begin{cases} y = 2x + 14 \\ x = 14 - 3y \end{cases}$$

$$19. \begin{cases} 7x - y = 16 \\ 2y = 2 - 3x \end{cases}$$

$$20. \begin{cases} 3x + y = -10 \\ 2y - 1 = x \end{cases}$$

$$21. \begin{cases} 4x - 2y = 8 \\ 2x - y = 4 \end{cases}$$

$$22. \begin{cases} x + y = 6 \\ 2x + y = 16 \end{cases}$$

$$23. \begin{cases} 3x + 2y = 4 \\ x + 5y = -3 \end{cases}$$

$$24. \begin{cases} x + 2y = 0 \\ 2x = 4y \end{cases}$$

$$25. \begin{cases} 4x + 3y = 2 \\ 3x + 2y = 3 \end{cases}$$

$$26. \begin{cases} x - 3y = 4 \\ 3x - 9y = 10 \end{cases}$$

$$27. \begin{cases} 5x - 2y = 17 \\ 2x - 3y = 9 \end{cases}$$

$$28. \begin{cases} \frac{1}{2}x + 2y = 9 \\ 2x - 3y = 14 \end{cases}$$

$$29. \begin{cases} 3x + 2y = 14 \\ 7x + 3y = 26 \end{cases}$$

$$30. \begin{cases} 4x + 3y = 28 \\ 5x + 2y = 35 \end{cases}$$

$$31. \begin{cases} 2x + 7y = 2 \\ 5x + 3y = -24 \end{cases}$$

$$32. \begin{cases} 7x - 6y = -1 \\ 5x + 2y = 37 \end{cases}$$

$$33. \begin{cases} 10x + 4y = 7 \\ 5x + 2y = 15 \end{cases}$$

$$34. \begin{cases} 6x - 5y = -40 \\ 8x - 7y = -54 \end{cases}$$

$$35. \begin{cases} 0.5x - 0.3y = 7 \\ 0.3x - 0.4y = 2 \end{cases}$$

$$36. \begin{cases} 0.6x + 0.5y = 5.9 \\ 0.8x + 0.4y = 6 \end{cases}$$

$$37. \begin{cases} 2.5x + 1.8y = 7 \\ 3.5x - 2.7y = 4 \end{cases}$$

$$38. \begin{cases} 0.75x - 0.5y = 2 \\ 1.5x - 0.75y = 7.5 \end{cases}$$

$$39. \begin{cases} \frac{2}{3}x - \frac{1}{2}y = \frac{2}{3} \\ \frac{8}{3}x - 2y = \frac{17}{6} \end{cases}$$

$$40. \begin{cases} \frac{3}{4}x + \frac{1}{4}y = \frac{3}{8} \\ \frac{3}{2}x + \frac{1}{2}y = \frac{3}{4} \end{cases}$$

$$41. \begin{cases} \frac{1}{6}x - \frac{1}{12}y = -\frac{13}{6} \\ \frac{1}{5}x + \frac{1}{4}y = 2 \end{cases}$$

$$42. \begin{cases} \frac{5}{3}x - \frac{2}{3}y = -\frac{29}{30} \\ 2x + 5y = 0 \end{cases}$$

Write an equation for the line determined by the two given points by using the formula $y = mx + b$ to set up a system of equations with m and b as the unknowns. See Example 6.

$$43. (2, 3), (1, -2)$$

$$46. (5, 3), (5, -4)$$

$$44. (0, 6), (-3, -3)$$

$$47. (1, 2), (-3, 0)$$

$$45. (1, -3), (5, -3)$$

$$48. (-4, 2), (5, -1)$$

Applications

Each of the following applications has been modeled using a system of equations. Use the method of substitution or the method of addition to solve each system.

49.  For two months, Martin used the same snow removal company to help clear his property. The company has a fixed reservation rate per month, plus an hourly rate for the amount of time that is spent clearing snow. Martin received two bills from the snow removal company. The first bill was \$150 for 4 hours of snow removal and the second bill was \$200 for 6 hours of snow removal. Find the equation of the line that represents the snow removal company's fixed reservation rate and charge per hour. Round to the nearest cent if necessary.

50.  For two months, Milan used the same landscaping maintenance company. The company has a fixed reservation rate per month, plus an hourly rate for the amount of time that is spent on landscaping work. Milan received two bills from the landscaping company. The first bill was \$109.50 for 3.5 hours of landscaping work and the second bill was \$147.75 for 5.75 hours of landscaping work. Find the equation of the line that represents the landscaping company's fixed reservation rate and charge per hour. Round to the nearest cent if necessary.

51. Georgia had \$10,000 to invest, and she put the money into two accounts. One of the accounts will pay 6% interest and the other will pay 10%. How much did she put in each account if the interest from the 10% account exceeded the interest from the 6% account by \$40?

Let x be the amount in the 10% account and y be the amount in the 6% account.

The system that models the problem is
$$\begin{cases} x + y = 10,000 \\ 0.10x - 0.06y = 40 \end{cases}$$

52. A minor league baseball team has a game attendance of 4500 people. Tickets cost \$5 for children and \$8 for adults. The total revenue made at this game was \$26,100. How many adults and how many children attended the game?

Let x be the number of adults and y be the number of children.

The system that models the problem is
$$\begin{cases} x + y = 4500 \\ 8x + 5y = 26,100 \end{cases}$$

53. How many liters each of a 30% acid solution and a 40% acid solution must be used to produce 100 liters of a 36% acid solution?

Let x be the amount of 30% solution and y be the amount of 40% solution.

The system that models the problem is
$$\begin{cases} x + y = 100 \\ 0.30x + 0.40y = 0.36(100) \end{cases}$$

54. Two cars leave Denver at the same time traveling in opposite directions. One travels at an average speed of 55 mph and the other at 65 mph. In how many hours will they be 420 miles apart?

Let x be the time of travel for first car and y be the time of travel for second car.

The system that models the problem is
$$\begin{cases} x = y \\ 55x + 65y = 420 \end{cases}$$



55. You are deciding between two credit cards with similar rewards programs. The City credit card will give you 3500 points as a sign-up bonus and 1.5 points for every dollar you spend. The International credit card gives you 1000 points as a sign-up bonus and gives you 2 points for every dollar you spend. How much would you have to spend to earn the same amount of rewards on each credit card?
- Write two equations to represent the situation. Use the variable x to represent the number of dollars spent and the variable y to represent the total number of points earned.
 - Solve the system of equations by addition.
 - What does the solution mean? Write a complete sentence.
 - If you only plan to purchase \$4000 in merchandise, which credit card will give you the most points?

56. Barbara's Bombtastic Bakery uses chocolate chips in one type of cookie and in one type of muffin. The cookie recipe calls for 5 cups of chocolate chips and the muffin recipe calls for 2 cups of chocolate chips. The cookie recipe makes 30 large cookies and the muffin recipe makes 18 giant muffins. The bakery currently has 50 cups of chocolate chips and only has room in the display case for a combination of 360 cookies and muffins. The manager wants to determine how many of each item to bake to use all of the chocolate chips.
- Write two equations to represent the situation. Use the variable x to represent the number of batches of chocolate chip cookies and the variable y to represent the number of batches of muffins.
 - Solve the system of equations by addition.
 - What does the solution mean? Write a complete sentence.
 - If the manager makes the amount of chocolate chip cookies and muffins described in part c., will the bakery be able to fulfill an order for 150 chocolate chip cookies and 160 chocolate chip muffins?

Writing & Thinking

57. Explain, in your own words, why the answer to a system with infinite solutions is written as an ordered pair with variables.

The system of linear equations is as follows.

$$\begin{cases} 3x + 2y = 10.30 & \text{Three hot dogs and two orders of french fries cost \$10.30.} \\ 4x + 4y = 15.60 & \text{Four hot dogs and four orders of french fries cost \$15.60.} \end{cases}$$

Both equations are in standard form. Use the addition method to solve the system.

$$\begin{array}{r} \left\{ \begin{array}{l} [-2] (3x + 2y = 10.30) \longrightarrow -6x - 4y = -20.60 \\ (4x + 4y = 15.60) \longrightarrow 4x + 4y = 15.60 \end{array} \right. \\ \hline \begin{array}{r} -2x \quad = -5.00 \\ x \quad = 2.50 \end{array} \quad \text{Cost of one hot dog} \end{array}$$

Back substitute $x = 2.50$ into one of the original equations.

$$\begin{aligned} 3(2.50) + 2y &= 10.30 \\ 7.50 + 2y &= 10.30 \\ 2y &= 2.80 \\ y &= 1.40 \quad \text{Cost of one order of fries} \end{aligned}$$

One hot dog costs \$2.50 and one order of french fries costs \$1.40.

Now work margin exercise 6.

Margin Exercise Answers

- The wind speed was 0.5 miles per hour and Bob was running 4.5 miles per hour.
- 12:00 p.m. 3. 93 and 57 4. 12 dimes and 4 nickels 5. Enrique is 13 and Maria is 4.
- A soda costs \$1.25 and a water bottle costs \$0.80

6.4 Exercises

Practice

Solve each problem by setting up a system of two equations in two unknowns and solve. See Examples 1 through 6.

- The sum of two numbers is 56. Their difference is 10. Find the numbers.
- The sum of two numbers is 40. The sum of twice the larger and 4 times the smaller is 108. Find the numbers.
- The sum of two numbers is 36. Three times the smaller plus twice the larger is 87. Find the two numbers.
- The sum of two integers is 102, and the larger number is 10 more than three times the smaller. Find the two integers.
- The difference between two integers is 13, and their sum is 87. What are the two integers?
- The difference between two numbers is 17. Four times the smaller is equal to 7 more than the larger. What are the numbers?

Applications

Solve

7. Two angles are supplementary if the sum of their measures is 180° . Find two supplementary angles such that the smaller is 30° more than one half of the larger.

8. Two angles are complementary if the sum of their measures is 90° . Find two complementary angles such that one is 15° less than six times the other.

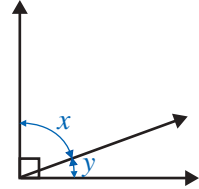

9. The sum of the measures of the three angles of a triangle is 180° . In an isosceles triangle, two of the angles have the same measure. What are the measures of the angles of an isosceles triangle in which one angle measures 15° more than each of the other two equal angles?

10. The sum of the measures of the three angles of a triangle is 180° . In an isosceles triangle, two of the angles have the same measure. What are the measures of the angles of an isosceles triangle in which each of the two equal angles measures 15° more than the third angle?

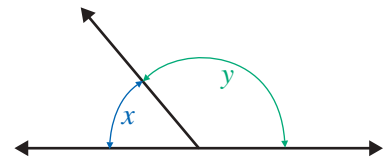

11. Liam makes a 4-mile motorboat trip downstream in 20 minutes ($\frac{1}{3}$ hr). The return trip takes 30 minutes ($\frac{1}{2}$ hr). Find the rate of the boat in still water and the rate of the current.

12. Mr. McKelvey finds that he can travel 1188 miles in 6 hours when flying with the wind. However, when flying against the wind, he travels only $\frac{2}{3}$ of the distance in the same amount of time. Find the speed of the plane in still air and the wind speed.

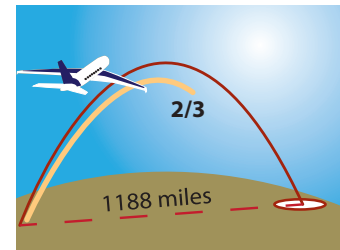

13. Usain Bolt, the world-record holder in the 100 meter dash, ran 100 meters in 9.69 seconds with no wind. He later ran the same distance in 9.58 seconds with the wind. What was his speed and what was the wind speed?
14. Jessica drove her speedboat upriver this morning. It took her 1 hour going upriver and 54 minutes going down river. If she traveled 36 miles each way, what would have been the rate of the boat in still water and what was the rate of the current (in miles per hour)?
15. Dominic went on a 190-mile business trip. He averaged 52 mph for the first part of the trip and 56 mph for the second part. If the total trip took $3\frac{1}{2}$ hours, how long did he travel at each rate?
16. Marian drove to a resort 335 miles from her home. She averaged 60 mph for the first part of her trip and 55 mph for the second part. If her total driving time was $5\frac{3}{4}$ hours, how long did she travel at each rate?

17. Marcos lives 364 miles away from his cousin Cana. They start driving at the same time and travel toward each other. Cana's speed is 11 mph faster than Marcos' speed. If they meet in 4 hrs, find their speeds.
18. Naomi and Linda live 324 miles apart. They start at the same time and travel toward each other. Naomi's speed is 8 mph greater than Linda's. If they meet in 3 hours, find their speeds.
19. Steve travels 4 times as fast as Tim. Starting at the same point, but traveling in opposite directions, they are 105 miles apart after 3 hours. Find their rates of travel.
20. Bella travels 5 mph less than twice as fast as June. Starting at the same point and traveling in the same direction, they are 80 miles apart after 4 hours. Find their speeds.
21. Two trains leave Dallas at the same time. One train travels east and the other travels west. The speed of the westbound train is 5 mph greater than the speed of the eastbound train. After 6 hours, they are 510 miles apart. Find the rate of each train. Assume the trains travel in a straight line in opposite directions.
22. A boat left Dana Point Marina at 11:00 a.m. traveling at 10 knots (nautical miles per hour). Two hours later, a Coast Guard boat left the same marina traveling at 14 knots trying to catch the first boat. If both boats traveled the same course, at what time did the Coast Guard captain anticipate overtaking the first boat?
23. A jogger runs into the countryside at a rate of 10 mph. He returns along the same route at 6 mph. If the total trip took 1 hour 36 minutes, how far did he jog?
24. A cyclist traveled to her destination at an average rate of 15 mph. By traveling 3 mph faster, she took 30 minutes less to return. What distance did she travel each way?
25. Sonja has some nickels and dimes. If she has 30 coins worth a total of \$2.00, how many of each type of coin does she have?
26. Conner has a total of 27 coins consisting of quarters and dimes. The total value of the coins is \$5.40. How many of each type of coin does he have?
27. A bag contains pennies and nickels only. If there are 182 coins in all and their value is \$3.90, how many pennies and how many nickels are in the bag?
28. Your friend challenges you to figure out how many dimes and quarters are in a cash register. He tells you that there are 65 coins and that their value is \$11.90. How many dimes and how many quarters are in the register?
29. The entry fee for a county carnival was \$3.50 for adults and \$2.50 for children. If the income for one day was \$9950 and the attendance was 3500 people, how many adults and how many children attended the carnival that day?
30. The width of a rectangle is $\frac{3}{4}$ of its length. If the perimeter of the rectangle is 140 feet, what are the dimensions of the rectangle?

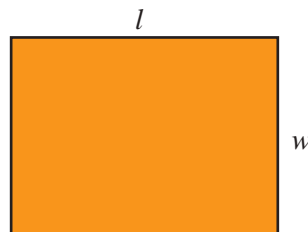

31. The length of a rectangle is 10 meters more than one half of the width. If the perimeter is 44 meters, what are the length and width?
32. A farmer has 260 meters of fencing to build a rectangular corral. He wants the length to be 3 times as long as the width. What dimensions should he make his corral?
33. At present, the length of a rectangular soccer field is 55 yards longer than the width. The city wants to rearrange the area containing the soccer field into two square playing fields. A math teacher on the council told them that if the width of the current field were to be increased by 5 yards and the length cut in half, the resulting field would be a square. What are the dimensions of the field currently?

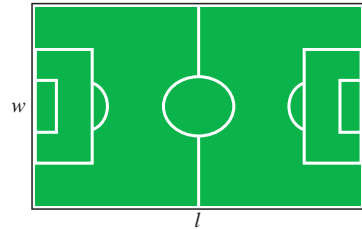

34. Consider a square and a regular hexagon (a six-sided figure with sides of equal length). One side of the square is 5 feet longer than a side of the hexagon, and the two figures have the same perimeter. What are the lengths of the sides of each figure?

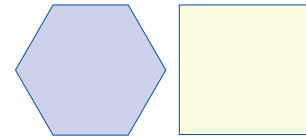

35. The length of a rectangle is 1 meter less than twice the width. If each side is increased by 4 meters, the perimeter will be 116 meters. Find the length and the width of the original rectangle.
36. Ava is 8 years older than her brother Curt. Four years from now, Ava will be twice as old as Curt. How old is each at the present time?
37. When they got married, Elvis Presley was 11 years older than his wife Priscilla. One year later, Priscilla was two-thirds of Elvis' age. How old was each of them when they got married?
38. A Christmas charity party sold tickets for \$45.00 for adults and \$25.00 for children. The total number of tickets sold was 320 and the total for the ticket sales was \$13,000. How many adult and how many children's tickets were sold?
39. Joan went to a book sale on campus and bought paperback books for \$0.25 each and hardback books for \$1.75 each. If she bought a total of 15 books for \$11.25, how many of each type of book did she buy?
40. Morton took some backup batteries and aluminum cans to the recycling center. Their total weight was 180 pounds. He received 1.5¢ per pound for the batteries and 30¢ per pound for the cans. The total received was \$14.10. How many pounds of each did Morton have?
41. Admission to a high-school baseball game is \$2.00 for general admission and \$3.50 for reserved seats. The receipts for the season were \$36,250 for 12,500 paid admissions. How many of each ticket, general and reserved, were sold?
42. Seventy children and 160 adults attended a play. The total receipts were \$620. One adult ticket and 2 children's tickets cost \$7. Find the price of each type of ticket.

43. Last summer, Ernie sold surfboards. One style sold for \$625 and the other sold for \$550. He sold a total of 47 surfboards. How many of each style did he sell if the sales from each style were equal?



44. The Candy Shack sells a particular candy in two different size packages. One size sells for \$1.25 and the other sells for \$1.75. If the store received \$65.50 for 42 packages of candy, how many of each size were sold?
45. The pro shop at the Divots Country Club ordered two brands of golf balls. Titleless balls cost \$1.80 each and the Done Lob balls cost \$1.50 each. The total cost of Titleless balls exceeded the total cost of the Done Lob balls by \$108. If equal numbers of each brand were ordered, how many dozen of each brand were ordered?
46. Sellit Realty Company gets a 6% fee for selling improved properties and 10% for selling unimproved land. Last week, the total sales were \$220,000 and their total fees were \$16,400. What were the sales from each of the two types of properties?
47. A men's clothing store sells two styles of sports jackets, one selling for \$95 and one selling for \$120. Last month, the store sold 40 jackets, with receipts totaling \$4250. How many of each style did the store sell?
48. Frank bought 2 shirts and 1 pair of dress pants for a total of \$55. If he had bought 1 shirt and 2 pairs of dress pants, he would have paid \$68. What was the price of each shirt and each pair of dress pants?
49. At McDonalds, 3 Big Macs and 5 orders of medium French fries cost \$21.53. Six Big Macs and 2 orders of medium French fries cost \$28.34. What is the price of a Big Mac? What is the price of one order of medium French fries?
50. A bakery sells burnt and broken cookies for a discounted price. Burnt cookies are \$0.49 and broken cookies are \$0.70. If Spencer spends \$49.70 to buy 80 cookies for a game night with his friends, how many of each type of cookie did Spencer buy?
51. A small manufacturer produces two kinds of radios, model X and model Y . Model X takes 4 hours to produce and costs \$8 each to make. Model Y takes 3 hours to produce and costs \$7 each to make. If the manufacturer decides to allot a total of 58 hours and \$126 each week, how many of each model will be produced?
52. A furniture shop makes dining room chairs. Employees can build two styles of chairs. Style I takes 1 day and the materials cost \$60. Style II takes $1\frac{1}{2}$ days but the materials only costs \$30. If, during the last two months, they spent 36 days and \$1200 building chairs, how many chairs of each style did they build?



53. A petting zoo charges \$5 for children and \$10 for adults. On Tuesday, the petting zoo made \$1400 from ticket sales and sold a total of 200 tickets. How many adults and how many children visited the petting zoo on Tuesday?
- Write two equations to describe the situation. Use the variable c to represent the number of children and the variable a to represent the number of adults.
 - Solve the system of linear equations.
 - Use the solution from part b. to write a complete sentence to answer the question from the problem.
54. A boat tour travels 4 miles downstream in 20 minutes and the return trip upstream takes 30 minutes. Find the rate of the boat and the rate of the current.
- Change each time from minutes to hours. Write each time value as a fraction.
 - Use a table to set up a system of linear equations. Use the variable b to represent the rate of the boat and the variable c to represent the rate of the current.
 - Solve the system of linear equations.
 - Use the solution from part c. to write a complete sentence to answer the question from the problem.

Writing & Thinking

55. A two digit number can be written as ab , where a and b are the digits. We do not mean that the digits are multiplied, but the value of the number is $10a + b$. For example, the two digit number 34 has a value of $10 \cdot 3 + 4$. Set up and solve a system of equations for the following problem.
- The sum of the digits of a two digit number is 13. If the digits are reversed, then the value of the number is increased by 45. What is the number?

Back substitute $y = 30$ into one of the original equations.

$$x + (30) = 100$$

$$x = 70 \quad \text{Amount of 20\%}$$

70 gallons of the 20% solution should be added to 30 gallons of the 30% solution. This will produce 100 gallons of a 23% solution.

Now work margin exercise 4.

Margin Exercise Answers

1. Fergus has invested \$5000 at 9% and \$5800 at 12%.
2. He should invest \$2500 at 9% and \$6500 at 5%.
3. 50 ounces of the 18% solution and 100 ounces of the 12% solution.
4. 96 gallons of the 22% solution and 24 gallons of the 17% solution.

6.5 Exercises

Concept Check

Fill-in-the-Blank. Complete each sentence using information found in this section.

1. The formula used to calculate interest depends on the frequency of _____ and the type of _____.
2. In the interest formula $I = Prt$, P stands for the _____.
3. In the interest formula $I = Prt$, I stands for the interest _____ or _____.
4. In the interest formula $I = Prt$, r stands for the _____ of interest.
5. In the interest formula $I = Prt$, t stands for the _____ in years.
6. When solving a mixture problem, the basic plan is to write a/an _____ that deals with only one part of the mixture.

True/False. Determine whether each statement is true or false. If a statement is false, explain how it can be changed so that the statement will be true. (**Note:** There may be more than one acceptable change.)

7. When interest is calculated on an annual basis, we have $t = 0$ and the formula becomes $I = Pr$.
8. Problems involving mixture occur in the sciences such as physics and chemistry.
9. In an interest problem, time can be given in parts of a year.
10. When two or more items are mixed, the final mixture should satisfy certain conditions of percentage of concentration.

Applications

Solve each problem by setting up a system of two equations in two unknowns and solving the system. See Examples 1 through 4.

1. Carmen invested \$9000. She invested part in a 6% passbook account and the rest in a 10% certificate account. If her annual interest was \$680, how much did she invest at each rate?

2. Mr. Brown has \$12,000 invested. Part is invested at 6% and the remainder at 8%. If the annual interest from the 6% investment is \$230 more than the annual interest from the 8% investment, how much is invested at each rate?
3. Ten thousand dollars is invested, part at 5.5% and part at 6%. The annual interest from the 5.5% investment is \$251 more than the annual interest from the 6% investment. How much is invested at each rate?
4. On two investments totaling \$9500, Darius lost 3% on one and earned 6% on the other. If his net annual receipts were \$282, how much was each investment?
5. Merideth has money in two savings accounts. One rate is 8% and the other is 10%. If she has \$200 more in the 10% account, how much is invested at 8% if the total annual interest is \$101?
6. Money is invested at two rates. One rate is 9% and the other is 13%. If there is \$700 more invested at 9%, find the amount invested at each rate if the total annual interest is \$239.
7. Ethan has half of his investments in stock paying an 11% dividend and the other half in a debentured stock paying 13% interest. If his total annual interest is \$840, how much does he have invested?
8. Betty invested some of her money at 12% interest. She invested \$300 more than twice that amount at 10%. How much is invested at each rate if her interest income is \$318 annually?
9. A company invested some money in a development yielding 24% and \$9000 less in a development yielding 18%. If the first investment produces \$2820 more per year than the second, how much is invested in each development?
10. Victoria invests a certain amount of money at 7% annual interest and three times that amount at 8%. If her annual interest income is \$232.50, how much does she have invested at each rate?
11. Jamal has a certain amount of money invested at 5% annual interest and \$500 more than twice that amount invested in bonds yielding 7%. His total annual income from interest is \$187. How much does he have invested at each rate?
12. A total of \$6000 is invested, part at 8% and the remainder at 12%. How much is invested at each rate if the annual interest is \$620?
13. Ms. Merriman has invested \$12,000. Part is invested at 9% and the remainder at 11%. If the interest from the 9% investment is \$380 more than the interest from the 11% investment, how much is invested at each rate?
14. Eight thousand dollars is invested, part at 15% and the remainder at 12%. If the annual interest income from the 15% investment is \$66 more than the annual interest income from the 12% investment, how much is invested at each rate?
15. Morgan inherited \$124,000 from her uncle. She invested a portion in bonds and the remainder in a long-term certificate account. The amount invested in bonds was \$24,000 less than 3 times the amount invested in certificates. How much was invested in bonds and how much in certificates?

16. Sang has invested \$48,000, part at 6% and the rest in a higher risk investment at 10%. How much did she invest at each rate to receive \$4000 in interest after one year?
17. A metallurgist has one alloy containing 20% copper and another containing 70% copper. How many pounds of each alloy must he use to make 50 pounds of a third alloy containing 50% copper?
18. A manufacturer has received an order for 24 tons of a 60% copper alloy. His stock contains only alloys of 80% copper and 50% copper. How much of each will he need to melt together to fill the order?
19. A tobacco shop wants 50 ounces of tobacco that is 24% rare Turkish blend. How much each of a 30% Turkish blend and a 20% Turkish blend will be needed?
20. How many liters each of a 40% acid solution and a 55% acid solution must be used to produce 60 liters of a 45% acid solution?
21. A dairy farmer wants to mix a 35% protein supplement and a standard 15% protein supplement to make 1800 pounds of a high-grade 20% protein supplement. How many pounds of each should he use?
22. To meet the government's specifications, a certain alloy must be 65% aluminum. How many pounds each of a 70% aluminum alloy and a 54% aluminum alloy will be needed to produce 640 pounds of the 65% aluminum alloy?
23. A butcher shop has ground beef that is 40% fat and extra lean ground beef that is only 15% fat. How many pounds of each will be needed to obtain 50 pounds of lean ground beef that is 25% fat?
24. George decides to mix grades of gasoline in his truck. He puts in 8 gallons of regular and 12 gallons of premium for a total cost of \$55.80. If premium gasoline costs \$0.15 more per gallon than regular, what was the price of each grade of gasoline?
25. How many grams of pure acid (100% acid) and how many grams of a 40% solution should be mixed together to get a total of 30 grams of a 60% solution?
26. Dark chocolate made with 100% cacao by weight is mixed with dark chocolate that is 60% cacao. How much of each (100% cacao and 60% cacao) should be used to get a mixture of 50 pounds of chocolate that is 70% cacao by weight?
27. Pure salt is to be added to a 4% salt solution. How many ounces of salt and how many ounces of the 4% solution should be mixed together to get 60 ounces of a 20% salt solution?
28. How many liters each of a 12% iodine solution and a 30% iodine solution must be used to produce a total mixture of 90 liters of a 22% iodine solution?
29. A candymaker is making truffles using a mixture of a melted dark chocolate that is 72% cocoa and milk chocolate that is 42% cocoa. If she wants 6 pounds of melted chocolate that is 52% cocoa, how much of each type of chocolate does she need?
30. A dairy supplier needs 360 gallons of milk containing 4% butterfat. How many gallons each of milk containing 5% butterfat and milk containing 2% butterfat must be used to obtain the desired 360 gallons?

31.  Care guidelines recommend that new body piercings are cleaned with a 1% salt solution for the first few weeks with the new piercing. You have a 0.5% solution and a 5% solution, and you need to make 8 ounces of the 1% solution. How much of the 0.5% and 5% solutions will you need? (Round your answers to the nearest hundredth.)
32. A pharmacist has two solutions of alcohol. One is 25% alcohol. The other is 45% alcohol. He wants to mix these two solutions to get 36 ounces that is 30% alcohol. How many ounces of each of these two solutions should he mix together?
33. Sanjay has \$5000 to invest, and he has an option to split the amount between two simple interest accounts. Account A is expected to earn 4% interest and Account B is expected to earn 9% interest. If he has a goal to make \$350 in interest after one year, how much should he invest in each account?
- Use a table to set up a system of linear equations to describe the situation. Use the variable x to represent the amount invested in Account A and the variable y to represent the amount invested in Account B.
 - Solve the system of linear equations from part a.
 - Write a complete sentence to answer the question from the problem.
 - Is it possible for Sanjay to earn more than \$350 in interest? If yes, explain how.
34. You have 3% hydrogen peroxide and 12% hydrogen peroxide. You need 20 ounces of 6% hydrogen peroxide. How many ounces of each grade of hydrogen peroxide do you need to mix together to obtain the required amount of 6% hydrogen peroxide?
- Set up a system of linear equations to describe the situation. Use the variable x to represent the amount of 3% solution and the variable y to represent the amount of 12% solution.
 - Solve the system of linear equations.
 - Write a complete sentence to answer the question from the problem.
35. King Nut Company sells freshly roasted nuts. A one-pound bag of broken fancy cashews costs \$5. A one-pound bag of almonds costs \$7.50. The manager wants to sell a mixture of the nuts that will cost \$6.50 for a one-pound bag. How much of each type of nut should he combine to make a one-pound bag of mixed nuts?
- Write two equations to describe the situation. Use the variable x to represent the amount of cashews and the variable y to represent the amount of almonds.
 - Solve the system of linear equations.
 - Write a complete sentence to answer the question from the problem.

Writing & Thinking

36. Your friend has \$20,000 to invest and decided to invest part at 4% interest and the rest at 10% interest. Why might you advise him (or her) to invest all of it
- at 4%?
 - at 10%?

4. Use a TI-84 Plus graphing calculator to graph the following system of linear inequalities.

$$\begin{cases} y - 2x \geq -5 \\ y + 4x < 7 \end{cases}$$

Example 4 Graphing Systems of Linear Inequalities

Use a graphing calculator to graph the system of linear inequalities: $\begin{cases} 2x + y < 4 \\ 2x - y \leq 0 \end{cases}$

Solution

Step 1: First, solve each inequality for y : $\begin{cases} y < -2x + 4 \\ y \geq 2x \end{cases}$

Note: Solving $2x - y \leq 0$ for y can be written as $2x \leq y$ and then as $y \geq 2x$.

Step 2: Press the $\boxed{Y=}$ key and enter both functions and the corresponding symbols as they appear here. Remember, to shade your graphs, position the cursor over the slash next to Y_1 (or Y_2) and press $\boxed{\text{ENTER}}$ repeatedly until the desired graphing symbol is displayed.

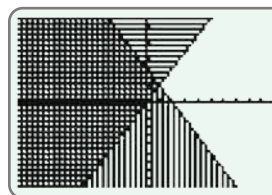
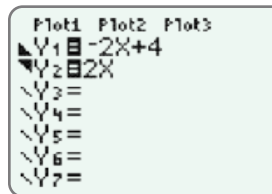

Step 3: Press $\boxed{\text{GRAPH}}$. The graph should appear as shown. The solution is the cross-hatched region and the points on the line $2x - y = 0$, where $x < 1$.

Now work margin exercise 4.

Margin Exercise Answers

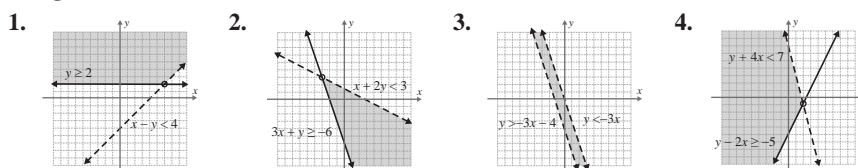

6.6 Exercises

Concept Check

Fill-in-the-Blank. Complete each sentence using information found in this section.

- To check the graph of a system of linear inequalities, a/an _____ - _____ should be chosen to determine whether or not it satisfies both inequalities.
- When graphing an inequality such as $y > mx + b$, the line $y = mx + b$ is called the _____ line.
- If a boundary line is included in the solution, the half-plane is _____.
- When a boundary line is not included in the solution, the half-plane is _____.
- If the boundary lines are parallel, there are _____ possible types of solutions.
- The solution set of a system of two linear inequalities consists of the points in the _____ of the two half-planes and portions of the boundary lines.

True/False. Determine whether each statement is true or false. If a statement is false, explain how it can be changed so the statement will be true. (**Note:** There may be more than one acceptable change.)

7. When boundary lines are parallel, the system of linear inequalities has no solution.
8. If two half-planes overlap, that region is the union of the graphs.
9. Half-planes are the graphs of linear inequalities.
10. If the graphs of two linear inequalities have no intersection, then the system has no solution.

Practice

Solve the systems of two linear inequalities graphically. See Example 1 through 3.

$$1. \begin{cases} y > 2 \\ x \geq -3 \end{cases}$$

$$9. \begin{cases} x - y \geq 0 \\ 3x - 2y \geq 4 \end{cases}$$

$$17. \begin{cases} x + y \geq 0 \\ x - 2y \geq 6 \end{cases}$$

$$2. \begin{cases} 2x + 5 < 0 \\ y \geq 2 \end{cases}$$

$$10. \begin{cases} y \geq x - 2 \\ x + y \geq -2 \end{cases}$$

$$18. \begin{cases} y \geq 2x + 3 \\ y \leq x - 2 \end{cases}$$

$$3. \begin{cases} x < 3 \\ y > -x + 2 \end{cases}$$

$$11. \begin{cases} 3x + y \leq 10 \\ 5x - y \geq 6 \end{cases}$$

$$19. \begin{cases} x + 3y \leq 9 \\ x - y \geq 5 \end{cases}$$

$$4. \begin{cases} y \leq -5 \\ y \geq x - 5 \end{cases}$$

$$12. \begin{cases} y > 3x + 1 \\ -3x + y < -1 \end{cases}$$

$$20. \begin{cases} x - y \geq -2 \\ x + 2y < -1 \end{cases}$$

$$5. \begin{cases} x \leq 3 \\ 2x + y > 7 \end{cases}$$

$$13. \begin{cases} 3x + 4y \geq -7 \\ y < 2x + 1 \end{cases}$$

$$21. \begin{cases} y \leq x + 3 \\ x - y \leq -5 \end{cases}$$

$$6. \begin{cases} 2x - y > 4 \\ y < -1 \end{cases}$$

$$14. \begin{cases} 2x - 3y \geq 0 \\ 8x - 3y < 36 \end{cases}$$

$$22. \begin{cases} y \geq 2x - 5 \\ 3x + 2y > -3 \end{cases}$$

$$7. \begin{cases} x - 3y \leq 3 \\ x < 5 \end{cases}$$

$$15. \begin{cases} x + y < 4 \\ 2x - 3y < 3 \end{cases}$$

$$23. \begin{cases} y \leq -2x \\ y > -2x - 6 \end{cases}$$

$$8. \begin{cases} 3x - 2y \geq 8 \\ y \geq 0 \end{cases}$$

$$16. \begin{cases} 2x + 3y < 12 \\ 3x + 2y > 13 \end{cases}$$

$$24. \begin{cases} y > x - 4 \\ y < x + 2 \end{cases}$$

 Use a graphing calculator to solve the systems of linear inequalities. See Example 4.

$$25. \begin{cases} y \geq 0 \\ 3x - 5y \leq 10 \end{cases}$$

$$29. \begin{cases} 3x - 4y \geq -6 \\ 3x + 2y \leq 12 \end{cases}$$

$$33. \begin{cases} y \leq x \\ y < 2x + 1 \end{cases}$$

$$26. \begin{cases} y \leq 0 \\ 3x + y \leq 11 \end{cases}$$

$$30. \begin{cases} 3y \leq 2x + 2 \\ x + 2y \leq 11 \end{cases}$$

$$34. \begin{cases} x - y \geq -2 \\ 4x - y < 16 \end{cases}$$

$$27. \begin{cases} 4x - 3y \geq 6 \\ 3x - y \leq 3 \end{cases}$$

$$31. \begin{cases} x + y \leq 8 \\ 3x - 2y \geq -6 \end{cases}$$

$$28. \begin{cases} 3x + 2y \leq 15 \\ 2x + 5y \geq 10 \end{cases}$$

$$32. \begin{cases} x + y \leq 7 \\ 2x - y \leq 8 \end{cases}$$

Applications

Solve.

35. Barbara's Bombtastic Bakery sells cookie bouquets where the price depends on the arrangement. Each completed bouquet arrangement needs to weigh less than 5 pounds for shipping purposes. The small cookies weigh 0.1 pounds and the large cookies weigh 0.3 pounds. The flower pot and Styrofoam weigh 1.2 pounds. The cost of each arrangement needs to be less than \$30. The small cookies cost \$1 each and the large cookies cost \$2 each. (The cost of the flower pot and foam are included in the cookie prices.)
- Write two linear inequalities to describe the situation. Use the variable x to represent the number of small cookies and the variable y to represent the number of large cookies in a bouquet.
 - Graph the two linear inequalities on the same coordinate plane.
 - Describe the solution set for the situation.
 - Do any of the values in the solution set not make sense in the context of the problem? Explain why or why not.
36. Robin is planning a charity ball to raise money for her favorite charity. There are two different ticket options. The VIP option includes dinner, dancing, and cocktails for \$150 per ticket. The regular option includes dancing and cocktails for \$75 per ticket. Robin wants to make at least \$14,000 in ticket sales. The ballroom that is being used for the charity event has a maximum capacity of 150 people.
- Write two linear inequalities to describe the situation. Let the variable x represent the number of VIP tickets sold and let the variable y represent the number of regular tickets sold.
 - Graph the two linear inequalities on the same coordinate plane.
 - Describe the solution set for the situation.
 - Can Robin reach her sales goal if she only sells tickets for the regular option? Explain why or why not.

Writing & Thinking

37. Graph the inequalities and explain how you can tell that there is no solution.

$$\begin{cases} y \leq 2x - 5 \\ y \geq 2x + 3 \end{cases}$$

7.1 Exercises

Concept Check

Fill-in-the-Blank. Complete each sentence using information found in this section.

- The quotient rule for exponents says that when dividing two powers with the same base, keep the base and _____ the exponents.
- The product rule for exponents says that when multiplying two powers with the same base, keep the base and _____ the exponents.
- An expression is considered simplified if each base appears only once and each base has only _____ exponents.
- The expression 0^0 is _____.
- For all real values of a , $a^1 = \underline{\hspace{1cm}}$.
- For all real values of a , $a^0 = \underline{\hspace{1cm}}$.

True/False. Determine whether each statement is true or false. If a statement is false, explain how it can be changed so the statement will be true. (**Note:** There may be more than one acceptable change.)

- If a constant does not have an exponent written, it is assumed that the exponent is 0.
- If a is a nonzero real number and n is an integer, then $a^{-n} = -a^n$.
- Since the product rule is stated for integer exponents, the rule is also valid for 0 and negative exponents.
- When using the quotient rule, you should subtract the smaller exponent from the larger exponent.

Practice

Simplify each expression. The final form of the expressions with variables should contain only positive exponents. Assume that all variables represent nonzero numbers. See Examples 1 through 7.

- | | | |
|--------------------|---------------------|---------------------|
| 1. $3^2 \cdot 3$ | 10. $(-4)^3 (-4)^0$ | 17. $-3(5^{-2})$ |
| 2. $7^2 \cdot 7^3$ | 11. $3(2^3)$ | 18. $-5(2^{-2})$ |
| 3. $8^3 \cdot 8^0$ | 12. $6(3^2)$ | 19. $x^2 \cdot x^3$ |
| 4. $5^0 \cdot 5^2$ | 13. $-4(5^3)$ | 20. $x^3 \cdot x$ |
| 5. 3^{-1} | 14. $-2(3^3)$ | 21. $y^2 \cdot y^0$ |
| 6. 4^{-2} | 15. $3(2^{-3})$ | 22. $y^3 \cdot y^8$ |
| 7. 5^{-2} | 16. $4(3^{-2})$ | 23. x^{-3} |
| 8. 6^{-3} | | 24. y^{-2} |
| 9. $(-2)^4 (-2)^0$ | | |

- | | | |
|--------------------------|----------------------------------|--|
| 25. $2x^{-1}$ | 46. $\frac{x^{-3}}{x}$ | 66. $\frac{-10x^5}{2x}$ |
| 26. $5y^{-4}$ | 47. $\frac{x^4}{x^{-2}}$ | 67. $\frac{-8y^4}{4y^2}$ |
| 27. $-8y^{-2}$ | 48. $\frac{x^5}{x^{-1}}$ | 68. $\frac{12x^6}{-3x^3}$ |
| 28. $-10x^{-3}$ | 49. $\frac{x^{-3}}{x^{-5}}$ | 69. $\frac{x^{-1} \cdot x^2}{x^3}$ |
| 29. $5x^6y^{-4}$ | 50. $\frac{x^{-4}}{x^{-1}}$ | 70. $\frac{x \cdot x^3}{x^{-3}}$ |
| 30. x^0y^{-2} | 51. $\frac{y^{-2}}{y^{-4}}$ | 71. $\frac{10^4 \cdot 10^{-3}}{10^{-2}}$ |
| 31. $3x^0 + y^0$ | 52. $\frac{y^3}{y^{-3}}$ | 72. $\frac{10 \cdot 10^{-1}}{10^2}$ |
| 32. $5y^0 - 3x^0$ | 53. $3x^3 \cdot x^0$ | 73. $(9x^2)^0$ |
| 33. $\frac{7^3}{7}$ | 54. $3y \cdot y^4$ | 74. $(-2x^{-3}y^5)^0$ |
| 34. $\frac{9^5}{9^2}$ | 55. $x^3 \cdot x^2 \cdot x^{-1}$ | 75. $(9x^2y^3)(-2x^3y^4)$ |
| 35. $\frac{10^3}{10^4}$ | 56. $x^{-3} \cdot x^0 \cdot x^2$ | 76. $(-3xy)(-5x^2y^{-3})$ |
| 36. $\frac{10}{10^5}$ | 57. $(4x^3)(9x^0)$ | 77. $\frac{-8x^2y^4}{4x^3y^2}$ |
| 37. $\frac{2^3}{2^6}$ | 58. $(5x^2)(3x^4)$ | 78. $\frac{-8x^{-2}y^4}{4x^2y^{-2}}$ |
| 38. $\frac{5^7}{5^4}$ | 59. $(-2x^2)(7x^3)$ | 79. $(3a^2b^4)(4ab^5c)$ |
| 39. $\frac{x^4}{x^2}$ | 60. $(3y^3)(-6y^2)$ | 80. $(-6a^3b^4)(4a^{-2}b^8)$ |
| 40. $\frac{x^6}{x^3}$ | 61. $(-4x^5)(3x)$ | 81. $\frac{36a^5b^0c}{-9a^{-5}b^{-3}}$ |
| 41. $\frac{x^3}{x}$ | 62. $(6y^4)(5y^5)$ | 82. $\frac{7x^2y^{-2}}{28x^0yz^{-2}}$ |
| 42. $\frac{y^7}{y^2}$ | 63. $\frac{8y^3}{2y^2}$ | 83. $\frac{25y^6 \cdot 3y^{-2}}{15xy^4}$ |
| 43. $\frac{x^7}{x^3}$ | 64. $\frac{12x^4}{3x}$ | 84. $\frac{12a^{-2} \cdot 18a^4}{36a^2b^{-5}}$ |
| 44. $\frac{x^8}{x^3}$ | 65. $\frac{9y^5}{3y^3}$ | |
| 45. $\frac{x^{-2}}{x^2}$ | | |

 Use a graphing calculator to evaluate each expression. Round quotients to the nearest ten-thousandth, if necessary. See Example 8.

- | | | |
|-----------------|------------------|-------------------------|
| 85. $(2.16)^0$ | 87. $(1.6)^{-2}$ | 89. $(6.4)^4(2.3)^2$ |
| 86. $(-5.06)^2$ | 88. $(2.5)^{-4}$ | 90. $(-14.8)^2(21.3)^2$ |

Applications

Solve.

91. Rylee wants to move all her files to a new hard drive that has 2^{12} GB of storage on it. She wants to designate the same amount of storage for each of 2^4 projects. How much storage should be assigned to each project? Write your answer as a power of two.
92. Trey is studying patterns in bacteria. For a positive test result in his experiment, bacteria must grow in population at a minimum rate of 3^2 in 24 hours. If the initial population of the bacteria is 3^5 and his final measurement after 24 hours is 3^8 , should he mark the test as positive or negative?
93. A molecule being studied under a powerful microscope is cubic in shape. What is the volume of the molecule if the length of one side is 10^{-8} cm?
94. A hurricane caused flooding in a home at the rate of 2^3 ft³ per hour. If that home has a storage closet that is 2^1 feet wide, 2^3 feet long, and 2^4 feet high, how long will it take the storage closet to fill with water? Write your answer as a power of 2.
95. A conference center needs an array of gift bags set up for a meeting. There will be 2^5 gift bags per row and 2^4 rows of gift bags. The delivery truck can hold 2^9 gift bags per load. How many deliveries will the truck need to make in order to supply the gift bags needed?
96. A local children's convention receives donations of 2^8 bags of candy for use as gifts for attendees. The convention has 2^7 children attending. How many bags of candy will each child receive?
97. Molly buys land that is 3^4 yards wide and 3^5 yards long. What is the area of the land? Write your answer as a power of 3.
98. Samuel wants to buy grass seed to plant in his yard. His lawn is 2^6 feet wide and 27 feet long. Each bag of grass seed will cover 2^{10} square feet. How many bags of seed should he purchase? Write your answer as a power of 2.

99. Barbara's Bombtastic Bakery makes *petit four glaces*, which are small bite-sized cakes. Each cake is in the shape of a cube that has a side length of $2x$, where x is a positive length which varies depending on the cake flavor.

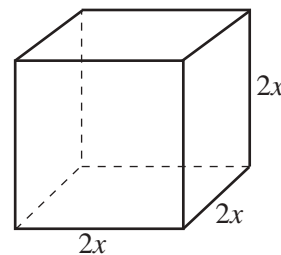

- a. Write an expression using exponents to find the volume of the *petit four glaces*. Do not simplify.
- b. Which exponential rule will you need to use to simplify the expression from part a.?
- c. Simplify the expression from part a.
- d. If $x = 2$ cm, determine the volume of the *petit four glaces* using the expression from part c.

- 100.** A strain of the influenza virus is spreading throughout a community and the number of confirmed cases of the flu doubles every day. On day 0 (the initial day) of the outbreak, 1 person has the virus. On day 1 of the outbreak, $1 \cdot 2 = 2$ people will have the virus. On day 2 of the outbreak, $1 \cdot 2 \cdot 2 = 1 \cdot 2^2 = 4$ people will have the virus.
- Write an exponential expression to describe how many people will have influenza virus on day 5. Write as a power of 2 and simplify.
 - Write an exponential expression to describe how many people would have the virus on day n if 3 people had the virus on day 0 of the outbreak. Write the expression in exponential form and simplify.
 - Use the expression from part b. to determine the number of people that will have the virus on day 5 of the outbreak if 3 people had the virus on day 0?
- 101.** A standard hard drive has 2^{38} bytes of data. 1 gigabyte is equivalent to 230 bytes.
- Write an exponential expression to determine how many gigabytes are equivalent to 2^{38} bytes?
 - Simplify the expression from part a. to determine how many gigabytes are in 2^{38} bytes.
 - What rule of exponents did you use to simplify part b.?

A complete summary of the rules for exponents includes the following eight rules.

Summary of the Rules for Exponents

The following rules are true for any nonzero real numbers a and b and integers m and n .

1. The exponent 1: $a = a^1$
2. The exponent 0: $a^0 = 1$
3. The product rule: $a^m \cdot a^n = a^{m+n}$
4. The quotient rule: $\frac{a^m}{a^n} = a^{m-n}$
5. Negative exponents: $a^{-n} = \frac{1}{a^n}$.
6. Power rule: $(a^m)^n = a^{mn}$.
7. Power of a product: $(ab)^n = a^n b^n$.
8. Power of a quotient: $\left(\frac{a}{b}\right)^n = \frac{a^n}{b^n}$.

PROPERTIES

Margin Exercise Answers

1. a. x^{15} b. $\frac{1}{x^{12}}$ c. $\frac{1}{y^{15}}$ d. $\frac{1}{3^6}$ or $\frac{1}{9^3}$ or $\frac{1}{729}$ 2. a. $16x^2$ b. $x^7 y^7$ c. $81a^2 b^2$ d. $\frac{1}{a^3 b^3}$
 e. $\frac{x^6}{y^8}$ 3. a. $\frac{x^7}{y^7}$ b. $\frac{25}{36}$ c. $\frac{27}{a^3}$ d. $\frac{x^3}{216}$ 4. a. $\frac{-27x^3}{y^9}$ b. $\frac{16b^2}{a^2}$ 5. $\frac{y^{15}}{x^{30}}$ 6. $\frac{64}{225x^{18}y^2}$

7.2 Exercises

Concept Check

Fill-in-the-Blank. Complete each sentence using information found in this section.

1. Moving any term from the numerator to the denominator, or vice versa, changes the sign of the corresponding _____.
2. A power of a quotient (in fraction form) is found by raising both the _____ and the _____ to that power.
3. To find the value of a power raised to a power, _____ the exponents and _____ the base.
4. A power of a product can be found by _____ each factor to that power.
5. In an expression such as $-x^2$, we know that -1 is understood to be the _____ of x^2 .

True/False. Determine whether each statement is true or false. If a statement is false, explain how it can be changed so the statement will be true. (**Note:** There may be more than one acceptable change.)

6. Taking the reciprocal of a fraction changes the sign of any exponent in the fraction.
7. For an exponent to refer to -7 as the base, -7 must be in parentheses.
8. When simplifying an expression with exponents, the rules for exponents must be used in a specific order or the answer will vary.
9. The expression -8^2 simplifies to -64 .

Practice

Use the rules for exponents to simplify each of the expressions. Assume that all variables represent nonzero real numbers. See Examples 1 through 6.

- | | | |
|---------------------|--------------------------------------|---|
| 1. -3^4 | 20. $(-3x^4)^2$ | 35. $\left(\frac{6m^3}{n^5}\right)^0$ |
| 2. -5^2 | 21. $4(-3x^2)^3$ | 36. $\left(\frac{3x^2}{y^3}\right)^2$ |
| 3. -2^4 | 22. $7(2y^{-2})^4$ | 37. $\left(\frac{-2x^2}{y^{-2}}\right)^2$ |
| 4. -20^2 | 23. $5(x^2y^{-1})$ | 38. $\left(\frac{2x}{y^5}\right)^{-2}$ |
| 5. $(-10)^6$ | 24. $-3(7xy^2)^0$ | 39. $\left(\frac{x}{y}\right)^{-2}$ |
| 6. $(-4)^6$ | 25. $-2(3x^5y^{-2})^{-3}$ | 40. $\left(\frac{2a}{b}\right)^{-1}$ |
| 7. $(a^3)^2$ | 26. $-4(5x^{-3}y)^{-1}$ | 41. $\left(\frac{3x}{y^{-2}}\right)^{-1}$ |
| 8. $(b^2)^{-4}$ | 27. $\left(\frac{a}{b}\right)^4$ | 42. $\left(\frac{4a^2}{b^{-3}}\right)^{-3}$ |
| 9. $(x^{-5})^2$ | 28. $\left(\frac{x}{2}\right)^3$ | 43. $\left(\frac{-3}{xy^2}\right)^{-3}$ |
| 10. $(x^{-2})^{-3}$ | 29. $\left(\frac{2}{3}\right)^2$ | 44. $\left(\frac{5xy^3}{y}\right)^2$ |
| 11. $(2^4)^{-2}$ | 30. $\left(\frac{a}{4}\right)^3$ | 45. $\left(\frac{m^2n^3}{mn}\right)^2$ |
| 12. $(2^{-3})^{-2}$ | 31. $\left(\frac{x}{y}\right)^6$ | |
| 13. $(3y)^2$ | 32. $\left(\frac{2}{5}\right)^2$ | |
| 14. $(ab)^4$ | 33. $\left(\frac{3x}{y}\right)^3$ | |
| 15. $(-4xy)^2$ | 34. $\left(\frac{-4x}{y^2}\right)^2$ | |
| 16. $(3x^{-2})^2$ | | |
| 17. $(xy)^{-6}$ | | |
| 18. $(a^3b^{-2})^3$ | | |
| 19. $(6x^3)^2$ | | |

46. $\left(\frac{2ab^3}{b^2}\right)^4$

47. $\left(\frac{-7^2x^2y}{y^3}\right)^{-1}$

48. $\left(\frac{2ab^4}{b^2}\right)^{-3}$

49. $\left(\frac{5x^3y}{y^2}\right)^2$

50. $\left(\frac{2x^2y}{y^3}\right)^{-4}$

51. $\left(\frac{x^3y^{-1}}{y^2}\right)^2$

52. $\left(\frac{2a^2b^{-1}}{b^2}\right)^3$

53. $\left(\frac{6y^5}{x^2y^{-2}}\right)^2$

54. $\left(\frac{3x^4}{x^{-2}y^{-4}}\right)^3$

55. $\frac{(7x^{-2}y)^2}{(xy^{-1})^2}$

56. $\frac{(-5x^3y^4)^2}{(3x^{-3}y)^2}$

57. $\frac{(3x^2y^{-1})^{-2}}{(6x^{-1}y)^{-3}}$

58. $\frac{(2x^{-3})^{-3}}{(5y^{-2})^{-2}}$

59. $\frac{(4x^{-2})(6x^5)}{(9y)(2y^{-1})}$

60. $\frac{(5x^2)(3x^{-1})^2}{(25y^3)(6y^{-2})}$

61. $\left(\frac{3xy^3}{4x^2y^{-3}}\right)^{-1}\left(\frac{2x^3y^{-1}}{9x^{-3}y^{-1}}\right)^2$

62. $\left(\frac{5a^4b^{-2}}{6a^{-4}b^3}\right)^{-2}\left(\frac{5a^3b^4}{2^{-2}a^{-2}b^{-2}}\right)^3$

63. $\left(\frac{6x^{-4}yz^{-2}}{4^{-1}x^{-4}y^3z^{-2}}\right)^{-1}\left(\frac{2^{-2}xyz^{-3}}{12x^2y^2z^{-1}}\right)^{-2}$

64. $\left(\frac{3^{-5}a^5b^3c^{-1}}{3^{-2}abc}\right)^{-2}\left(\frac{7^{-1}a^{-4}bc^2}{7^{-2}a^{-3}bc^{-2}}\right)^{-2}$

 Use a graphing calculator to evaluate each expression. Round quotients to the nearest ten-thousandth, if necessary.

65. $(2.1^2)^2$

66. $(1.4^{-2})^5$

67. $(3.8x)^4$

68. $(5.2x^2)^3$

69. $\left(\frac{8.1}{1.7}\right)^2$

70. $\left(\frac{2.3}{4.5}\right)^3$

5. If light travels 3×10^8 meters per second, how many meters does light travel in one day?

Example 5 Application: Scientific Notation and Calculators

A light-year is the distance light travels in one year. Use a graphing calculator to find the length of a light-year in scientific notation if light travels 186,000 miles per second.

Solution

60 seconds = 1 minute
60 minutes = 1 hour
24 hours = 1 day
365 days = 1 year

Multiplication gives the following display on your calculator.

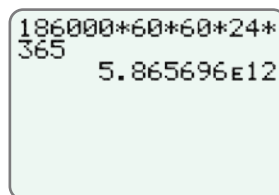

Thus, a light-year is 5.865696×10^{12} , or 5,865,696,000,000 miles (5 trillion, 865 billion, 696 million miles).

Now work margin exercise 5.

Margin Exercise Answers

1. a. 6.39×10^7 b. 2.45×10^{-6} 2. a. 1.8×10^{-5} b. 1.2×10^8 3. 4.816×10^{24} particles
4. a. $7E4$ b. $6E12$ 5. $2.592E13$ meters

7.3 Exercises

Concept Check

Fill-in-the-Blank. Complete each sentence using information found in this section.

- In scientific notation, decimal numbers are written as a product of a number greater than or equal to _____ and less than _____, and an integer power of 10.
- In scientific notation, there is/are _____ digit(s) to the left of the decimal point.
- The exponent of a number written in scientific notation tells how many places the _____ is to be moved and in what direction.

True/False. Determine whether each statement is true or false. If a statement is false, explain how it can be changed so the statement will be true. (**Note:** There may be more than one acceptable change.)

- The exponent in the number 1.4×10^4 indicates that the decimal point should be moved 4 places to the right.
- The exponent in the number 2.5×10^{-3} indicates that the decimal point should be moved 3 places to the right.
- The number 3.53×10^5 is less than 8.72×10^{-4} .
- The number 4000 written in scientific notation is 0.4×10^4 .

Practice

Write the following numbers in scientific notation. See Example 1.

- | | |
|----------------|---------------------|
| 1. 86,000 | 7. 0.0000000002368 |
| 2. 927,000 | 8. 1,030,000,000 |
| 3. 0.0362 | 9. 0.0000009 |
| 4. 0.0061 | 10. 0.0000000571 |
| 5. 18,300,000 | 11. 0.0000000000328 |
| 6. 376,000,000 | 12. 845,300,000 |

Write the following numbers in decimal form.

- | | |
|----------------------------|----------------------------|
| 13. 4.2×10^{-2} | 19. 3.067×10^{10} |
| 14. 8.35×10^{-3} | 20. 9.374×10^7 |
| 15. 7.56×10^6 | 21. 7.205×10^9 |
| 16. 1.002×10^{-7} | 22. 4×10^{11} |
| 17. 6.132×10^{-5} | 23. 6.91×10^{-6} |
| 18. 8.515×10^8 | 24. 7.408×10^{-9} |

First write each of the numbers in scientific notation. Then perform the indicated operations and leave your answer in scientific notation. See Example 2.

- | | |
|---|---|
| 25. $300 \cdot 0.00015$ | 36. $\frac{0.02 \cdot 3900}{0.013}$ |
| 26. $0.000024 \cdot 40,000$ | 37. $\frac{0.0084 \cdot 0.003}{0.21 \cdot 60}$ |
| 27. $0.0003 \cdot 0.0000025$ | 38. $\frac{0.005 \cdot 650 \cdot 3.3}{0.0011 \cdot 2500}$ |
| 28. $0.00005 \cdot 0.00013$ | 39. $\frac{5.4 \cdot 0.003 \cdot 50}{15 \cdot 0.0027 \cdot 200}$ |
| 29. $23,400,000,000 \cdot 5,500,000,000$ | 40. $\frac{0.00000000039 \cdot 15,000,000,000}{8,000,000 \cdot 0.0000000013}$ |
| 30. $7,800,000,000 \cdot 0.00000081$ | 41. $\frac{(1.4 \times 10^{-2})(922)}{(3.5 \times 10^3)(2.0 \times 10^6)}$ |
| 31. $\frac{3900}{0.003}$ | 42. $\frac{(4300)(3.0 \times 10^2)}{(1.5 \times 10^{-3})(860 \times 10^{-2})}$ |
| 32. $\frac{4800}{12,000}$ | 43. $\frac{(25)(3.75 \times 10^{-5})}{(0.4 \times 10^{11})(75 \times 10^{-7})}$ |
| 33. $\frac{125}{50,000}$ | |
| 34. $\frac{0.0046}{230}$ | |
| 35. $\frac{0.0000000000013}{0.000000026}$ | |

64. The world population is approximately 7.5×10^9 people. Write this number in decimal form.
65. The mass of the earth is about 5,980,000,000,000,000,000,000,000 grams. Write this number in scientific notation.
66. One year is approximately 31,500,000 seconds. Express this time in scientific notation.
67. One light-year is approximately 9.46×10^{15} meters. The distance to a certain star is 4.3 light-years. How many meters is this?
68. Light travels approximately 3×10^{10} centimeters per second. How many centimeters would this be per minute? Per hour? Express your answers in scientific notation.
69. The mass of an atom of gold is approximately 3.27×10^{-22} grams. What would be the mass of 2000 atoms of gold? Express your answer in scientific notation.
70. An ounce of gold contains 5×10^{22} atoms. All the gold ever taken out of the earth is estimated to be 3.0×10^{31} atoms. How many ounces of gold is this?
71. There are 8.64×10^4 seconds in a day. How many seconds are in 30 days? Express this time in scientific notation.
72. A scientist measured that his sample weighed 0.0000023 grams. He wrote the value as 2.3×10^6 g on a report. Did he write the value correctly in scientific notation? If not, what should it be?
73. A scientist calculated that her experiment consumed 520,000 joules (J) of energy. She wrote the value as 52×10^4 J on a report of the experiment. Did she write the value correctly in scientific notation? If not, what should it be?
74. A molecule of table salt weighs approximately 9.704×10^{-23} grams. What would be the weight of 4,000,000 molecules of table salt?
- Write 4,000,000 in scientific notation.
 - Write an expression to find the weight of 4,000,000 molecules of table salt.
 - Simplify the expression from part b.
 - What does the answer from part c. mean? Write a complete sentence.

6. Rewrite the polynomial expression $f(x) = 8x - 27$ by substituting for x as indicated by the function notation $f(3a - 1)$.

Example 6 Evaluating Polynomials

Rewrite the polynomial expression $f(x) = 6x + 13$ by substituting for x as indicated by the function notation $f(2a + 1)$.

Solution

Substitute $2a + 1$ for x throughout the polynomial.

$$\begin{aligned} f(2a + 1) &= 6(2a + 1) + 13 \\ &= 12a + 6 + 13 \\ &= 12a + 19 \end{aligned}$$

Now work margin exercise 6.

Completion Example Answers

2. $-2x^2 + 4x + 6$; second-degree polynomial 5. $5(3)^2 + 6(3) - 10 = 45 + 18 - 10 = 53$

Margin Exercise Answers

1. a. $9x^2$; second-degree monomial b. $9x^2 - 5x$; second-degree binomial c. $4y^3 - \frac{8}{3}y^2 + 8$; third-degree trinomial d. $4x^2 - 8$; second-degree binomial e. not a polynomial
2. $13x^3 - 2x^2 + 4$; third-degree trinomial 3. 23 4. -6 5. 68 6. $24a - 35$

7.4 Exercises

Concept Check

Fill-in-the-Blank. Complete each sentence using information found in this section.

- If the terms in a polynomial are written so that the exponents on the variable decrease in order from left to right, it is said that the expression is in _____ order.
- A monomial or an indicated sum or difference of monomials is known as a/an _____.
- In a polynomial, the coefficient of the term of the largest degree is called the _____ coefficient.
- Monomials may not have fractional or _____ exponents.
- A polynomial with two terms is called a/an _____.
- A trinomial is a polynomial with ____ terms.

True/False. Determine whether each statement is true or false. If a statement is false, explain how it can be changed so the statement will be true. (**Note:** There may be more than one acceptable change.)

- A nonzero constant is a monomial with no degree.
- A polynomial with four terms is a quadrimomial.
- A monomial is a polynomial with one term.
- A polynomial must have at least two terms.

Practice

Identify each expression as a monomial, binomial, trinomial, or not a polynomial.

- | | |
|---------------------|---------------------------------------|
| 1. $3x^4$ | 6. $17x^{\frac{2}{3}} + 5x^2$ |
| 2. $5y^2 - 2y + 1$ | 7. $6a^3 + 5a^2 - a^{-3}$ |
| 3. $8x^3 - 7$ | 8. $-3y^4 + 2y^2 - 9$ |
| 4. $-2x^{-2}$ | 9. $\frac{1}{2}x^3 - \frac{2}{5}x$ |
| 5. $14a^7 - 2a - 6$ | 10. $\frac{5}{8}x^5 + \frac{2}{3}x^4$ |

Simplify the polynomials. Write the polynomials in descending order and state the degree and type of each polynomial. Then, state the leading coefficient. See Examples 1 and 2.

- | | |
|---|--|
| 11. $y + 3y$ | 21. $4y - 8y^2 + 2y^3 + 8y^2$ |
| 12. $4x^2 - x + x^2$ | 22. $2x + 9 - x + 1 - 2x$ |
| 13. $x^3 + 3x^2 - 2x$ | 23. $5y^2 + 3 - 2y^2 + 1 - 3y^2$ |
| 14. $3x^2 - 8x + 8x$ | 24. $13x^2 - 6x - 9x^2 - 4x$ |
| 15. $x^4 - 4x^2 + 2x^2 - x^4$ | 25. $7x^3 + 3x^2 - 2x + x - 5x^3 + 1$ |
| 16. $2 - 6y + 5y - 2$ | 26. $-3y^5 + 7y - 2y^3 - 5 + 4y^2 + y^2$ |
| 17. $-x^3 + 6x + x^3 - 6x$ | 27. $x^4 + 3x^4 - 2x + 5x - 10 - x^2 + x$ |
| 18. $11x^2 - 3x + 2 - 7x^2$ | 28. $a^3 + 2a^2 - 6a + 3a^3 + 2a^2 + 7a + 3$ |
| 19. $6a^5 + 2a^2 - 7a^3 - 3a^2$ | 29. $2x + 4x^2 + 6x + 9x^3$ |
| 20. $2x^2 - 3x^2 + 2 - 4x^2 - 2 + 5x^2$ | 30. $15y - y^3 + 2y^2 - 10y^2 + 2y - 16$ |

Find the values of the functions as indicated. See Examples 3 through 5.

- | | |
|---|-----------------------------------|
| 31. Given $f(x) = 3x - 10$, find | 32. Given $g(x) = -4x + 7$, find |
| a. $f(2)$ | a. $g(-3)$ |
| b. $f(-2)$ | b. $g(6)$ |
| c. $f(0)$ | c. $g(0)$ |
| 33. Given $p(x) = x^2 + 14x - 3$, find $p(-1)$. | |
| 34. Given $h(x) = -5x^2 - 8x + 7$, find $h(-3)$. | |
| 35. Given $f(x) = 3x^3 - 9x^2 - 10x - 11$, find $f(3)$. | |
| 36. Given $f(y) = y^3 - 5y^2 + 6y + 2$, find $f(2)$. | |
| 37. Given $p(y) = -4y^3 + 5y^2 + 12y - 1$, find $p(-10)$. | |

38. Given $h(a) = a^3 + 4a^2 + a + 2$, find $h(-5)$.
39. Given $p(a) = 2a^4 + 3a^2 - 8a$, find $p(-1)$.
40. Given $g(x) = 8x^4 + 2x^3 - 6x^2 - 7$, find $g(-2)$.
41. Given $g(x) = x^5 - x^3 + x - 2$, find $g(-2)$.
42. Given $p(x) = 3x^6 - 2x^5 + x^4 - x^3 - 3x^2 + 2x - 1$, find $p(1)$.

A polynomial function is given. Rewrite the polynomial function by substituting for the variable as indicated in the given function notation.

43. Given $p(x) = 3x^4 + 5x^3 - 8x^2 - 9x$, find $p(a)$.
44. Given $p(x) = 6x^5 + 5x^2 - 10x + 3$, find $p(c)$.
45. Given $f(x) = 3x + 5$, find $f(a + 2)$.
46. Given $f(x) = -4x + 6$, find $f(a - 2)$.
47. Given $g(x) = 5x - 10$, find $g(2a + 7)$.
48. Given $g(x) = -4x - 8$, find $g(3a + 1)$.

Applications

Solve.

49. A car on an amusement park ride starts with an initial velocity (or initial speed) of 5 feet per second and accelerates at a rate of 15 feet per second squared. The speed of the car during the ride can be modeled by the polynomial $p(x) = 15x + 5$, where x is the time, in seconds, since the car started moving.
- Identify the degree of the polynomial.
 - Determine how fast the car is moving after 0 seconds.
 - Determine how fast the car is moving after 3 seconds.
 - Determine how fast the car is moving after 6 seconds.
50. A ball is thrown from the top of a building towards the ground with an initial velocity (or initial speed) of 12 feet per second. The force of gravity causes the ball to accelerate at a rate of 32 feet per second squared. The distance of the ball from the top of the building can be modeled by the polynomial $p(x) = 12x + 32x^2$ where x is the time, in seconds, since the ball was thrown.
- Identify the degree of the polynomial.
 - Determine how far the ball is from the top of the building at 1 second.
 - Determine how far the ball is from the top of the building at 2 seconds.
 - Determine how far the ball is from the top of the building at 3 seconds.



51. Chelsea is competing in a double-elimination softball tournament, which means that a team is eliminated once they lose two games. If the winning team goes undefeated, the total number of games played will be $G(t) = 2t - 1$, where t is the number of teams participating in the tournament.
- Identify the degree of the polynomial.
 - Determine how many games will be played if 5 teams are participating.
 - Determine how many games will be played if 6 teams are participating.
 - Determine how many games will be played if 15 teams are participating.
52. Max runs a no-kill dog shelter. To help manage finances for the upcoming year, Max uses data from the previous years to construct a mathematical model that can predict the number of dogs the shelter will have during each month of the upcoming year. The model he constructs is $D(x) = x^2 - 12x + 80$, where x is the number of the month of the year (this means that January = 1, February = 2, etc.).
- Identify the degree of the polynomial.
 - How many animals are predicted to be in the shelter in January?
 - How many animals are predicted to be in the shelter in July?
 - How many animals are predicted to be in the shelter in December?
53. The value of a car starts to depreciate the moment you drive it off of the car dealership's lot. After two years, the approximate value of a car that originally costs \$25,000 is calculated by $V = \$25,000x^2$, where x is the average percent that the car retains its value per year. Cars that are well taken care of and driven sparingly will retain more value than cars that are poorly maintained and driven frequently.
- Suppose that a car that is well maintained and rarely driven will retain an average of 90% of its value each year. What will be the approximate value of the car after 2 years?
 - Suppose that a car that is not well maintained will retain an average of 80% of its value each year. What will be the approximate value of the car after 2 years?
54. Forensic scientists can use a simple formula to approximate the time of death. This formula is based on the average body temperature of humans being 37°C and the fact that a deceased body will lose an average of 1.5°C per hour until the body temperature matches the temperature of the surrounding environment. The formula is $f(t) = 37 - 1.5t$, where t is the time in hours since death.
- What is the approximate body temperature of a person that died 4 hours ago?
 - What is the approximate body temperature of a person that died 14 hours ago?
 - If the temperature of the environment in which the body was found was 20°C , would it be reasonable for the body temperature to be the temperature from part b.? Explain why or why not.

55. A sled going down a hill has an initial speed of 5 feet per second and a constant acceleration of 1 foot per second squared. The distance of the sled in feet from the top of the hill can be modeled by the polynomial $d(t) = 5t + \frac{1}{2}t^2$, where t is the time in seconds after the sled leaves the top of the hill.
- Determine the distance the sled is from the top of the hill after 2 seconds.
 - Determine the distance the sled is from the top of the hill after 4 seconds.
 - Determine the distance the sled is from the top of the hill after 8 seconds.
 - Does the distance that the sled travels double when the time doubles? Explain why or why not.
56. Camilla is creating square baby quilts. She determines that the sale price of each quilt should be $p(x) = \$1.80x^2 + 4(\$0.50)x + \$15$, where x is the side length of each square blanket in feet, \$1.80 is the cost per square foot of material, \$0.50 is the cost per foot of border material, and \$15 is the amount of profit Camilla wants to make on each blanket.
- How much will a blanket that has a side length of 3 feet cost?
 - How much will a blanket that has a side length of 4 feet cost?
57. The value of an automobile depreciates linearly over time. A new 2018 Mercedes E300 sells for \$52,950 and its value, V , after t years is given by the equation $V = 52,950 - 3500t$. Find the value of the 2018 Mercedes in 2020 (e.g. after 2 years), and then in 2026.
58. PDQ Tennis Shoe Co. follows a profit model of $P = 3x^2 - 15x + 2$, where P is the profit in hundreds of dollars after selling x hundred pairs of tennis shoes. Find each of the profits for PDQ after selling 100 pairs, 500 pairs, and 1000 pairs of tennis shoes. What does a negative value for profit represent?
59.  The number of protozoa in a biology laboratory experiment is given by the polynomial function $p(t) = 0.04t^4 + 0.3t^3 + 2t^2$, where p is the number of protozoa after t hours. Determine the number of protozoa after 4 hours. What is the number of protozoa after 2 days? (Round both values to the nearest whole number.)
60. The percent p of material retained by a student x days after hearing a lecture is given by the polynomial function $p(x) = 100 - 5x^2$. What percent of the material is still remembered by a student 4 days after hearing the lecture?

Writing & Thinking

61. Tony was classifying expressions for a homework assignment. He said that $7y^2 + 12y - 3$ was a polynomial. Was he correct or not? Justify your answer.
62. Jeanne thought that $10a - 9 + 6a^2$ was in descending order. Explain Jeanne's error and what the correct descending order should be.

First-degree polynomials are also called linear polynomials, second-degree polynomials are called quadratic polynomials, and third-degree polynomials are called cubic polynomials. The related functions are called linear functions, quadratic functions, and cubic functions, respectively.

63.  Use a graphing calculator to graph the following linear functions. (See Section 5.5 to review graphing functions on a graphing calculator.)
- $p(x) = 2x + 3$
 - $p(x) = -3x + 1$
 - $p(x) = \frac{1}{2}x$
64.  Use a graphing calculator to graph the following quadratic functions.
- $p(x) = x^2$
 - $p(x) = x^2 + 6x + 9$
 - $p(x) = -x^2 + 2$
65.  Use a graphing calculator to graph the following cubic functions.
- $p(x) = x^3$
 - $p(x) = x^3 - 4x$
 - $p(x) = x^3 + 2x^2 - 5$
66. Make up a few of your own linear, quadratic, and cubic functions and graph these functions with your calculator. Using the results from Exercises 63, 64, and 65, and your own functions, describe in your own words:
- the general shape of the graphs of linear functions.
 - the general shape of the graphs of quadratic functions.
 - the general shape of the graphs of cubic functions.

7.5 Exercises

Concept Check

Fill-in-the-Blank. Complete each sentence using information found in this section.

- To find the difference between two polynomials, first change the _____ of each term in the second polynomial.
- If there are multiple grouping symbols within an algebraic expression, begin working on the _____ pair of symbols first.
- To add two or more polynomials, combine _____ terms.
- A negative sign written in front of a polynomial in parentheses indicates the _____ of the entire polynomial.
- To simplify algebraic expressions, apply the rules for order of operations just as if the _____ were numbers and proceed to combine like terms.
- Like terms have the same _____ raised to the same _____.

True/False. Determine whether each statement is true or false. If a statement is false, explain how it can be changed so the statement will be true. (**Note:** There may be more than one acceptable change.)

- When subtracting one polynomial from another polynomial, only the first term of the polynomial is subtracted.
- To simplify polynomials that are being added and subtracted, combine like terms.
- The terms $6a^2$ and $7a^2$ are not like terms because they don't have the same coefficient.
- Absolute value bars and radical signs are not considered grouping symbols.

Practice

Find the indicated sums. See Examples 1 through 3.

- $(2x^2 + 5x - 1) + (x^2 + 2x + 3)$
- $(x^2 + 3x - 8) + (3x^2 - 2x + 4)$
- $(x^2 + 7x - 7) + (x^2 + 4x)$
- $(x^2 + 2x - 3) + (x^2 + 5)$
- $(-4x^2 + 2x - 1) + (3x^2 - x + 2) + (x - 8)$
- $(8x^2 + 5x + 2) + (-3x^2 + 9x - 4) + (2x^2 + 6)$
- $(x^2 + 2x - 1) + (3x^2 - x + 2) + (2x^3 - 4x - 8)$
- $(x^3 + 2x - 9) + (x^2 - 5x + 2) + (x^3 - 4x^2 + 1)$
- $(2x^2 - x - 1) + (x^2 + x + 1)$
- $(3x^2 + 5x - 4) + (2x^2 + x - 6)$
- $(-2x^2 - 3x + 9) + (3x^2 - 2x + 8)$
- $(x^2 + 6x - 7) + (3x^2 + x - 1)$

$$13. \quad \begin{array}{r} x^2 + 4x - 4 \\ -2x^2 + 3x + 1 \\ \hline \end{array}$$

$$14. \quad \begin{array}{r} 2x^2 + 4x - 3 \\ 3x^2 - 9x + 2 \\ \hline \end{array}$$

$$15. \quad \begin{array}{r} x^3 + 3x^2 + x \\ -2x^3 - x^2 + 2x - 4 \\ \hline \end{array}$$

$$16. \quad \begin{array}{r} 4x^3 + 5x^2 + 11 \\ 2x^3 - 2x^2 - 3x - 6 \\ \hline \end{array}$$

$$17. \quad \begin{array}{r} 7x^3 + 5x^2 + x - 6 \\ -3x^2 + 4x + 11 \\ -3x^3 - 2x^2 - 5x + 2 \\ \hline \end{array}$$

$$18. \quad \begin{array}{r} x^3 + 5x^2 + 7x - 3 \\ 4x^2 + 3x - 9 \\ 4x^3 + 2x^2 - 2 \\ \hline \end{array}$$

$$19. \quad \begin{array}{r} x^3 + 3x^2 - 4 \\ 7x^2 + 2x + 1 \\ x^3 + x^2 - 6x \\ \hline \end{array}$$

$$20. \quad \begin{array}{r} x^3 + 2x^2 - 5 \\ -2x^3 + x - 9 \\ x^3 - 2x^2 + 14 \\ \hline \end{array}$$

Find the indicated differences. See Examples 4 through 6.

$$21. \quad (2x^2 + 4x + 8) - (x^2 + 3x + 2)$$

$$24. \quad (6x^2 + 11x + 2) - (4x^2 - 2x - 7)$$

$$22. \quad (3x^2 + 7x - 6) - (x^2 + 2x + 5)$$

$$25. \quad (2x^2 - x - 10) - (-x^2 + 3x - 2)$$

$$23. \quad (x^2 - 9x + 2) - (4x^2 - 3x + 4)$$

$$26. \quad (7x^2 + 4x - 9) - (-2x^2 + x - 9)$$

$$27. \quad (x^4 + 8x^3 - 2x^2 - 5) - (2x^4 + 10x^3 - 2x^2 + 11)$$

$$28. \quad (x^3 + 4x^2 - 3x - 7) - (3x^3 + x^2 + 2x + 1)$$

$$29. \quad (-3x^4 + 2x^3 - 7x^2 + 6x + 12) - (x^4 + 9x^3 + 4x^2 + x - 1)$$

$$30. \quad (2x^5 + 3x^3 - 2x^2 + x - 5) - (3x^5 - 2x^3 + 5x^2 + 6x - 1)$$

$$31. \quad (9x^2 - 5) - (13x^2 - 6x - 6)$$

$$32. \quad (8x^2 + 9) - (4x^2 - 3x - 2)$$

$$33. \quad (3x^4 - 2x^3 - 8x - 1) - (5x^3 - 3x^2 - 3x - 10)$$

$$34. \quad (x^5 + 6x^3 - 3x^2 - 5) - (2x^5 + 8x^3 + 5x + 17)$$

$$35. \quad \begin{array}{r} 14x^2 - 6x + 9 \\ -(8x^2 + x - 9) \\ \hline \end{array}$$

$$38. \quad \begin{array}{r} 11x^2 + 5x - 13 \\ -(-3x^2 + 5x + 2) \\ \hline \end{array}$$

$$36. \quad \begin{array}{r} 9x^2 - 3x + 2 \\ -(4x^2 - 5x - 1) \\ \hline \end{array}$$

$$39. \quad \begin{array}{r} x^3 + 6x^2 - 3 \\ -(-x^3 + 2x^2 - 3x + 7) \\ \hline \end{array}$$

$$37. \quad \begin{array}{r} 5x^4 + 8x^2 + 11 \\ -(-3x^4 + 2x^2 - 4) \\ \hline \end{array}$$

$$40. \quad \begin{array}{r} 3x^3 + 9x - 17 \\ -(x^3 + 5x^2 - 2x - 6) \\ \hline \end{array}$$

Simplify each of the following expressions. See Examples 7 and 8.

41. $5x + 2(x - 3) - (3x + 7)$

42. $-4(x - 6) - (8x + 2) - 3x$

43. $11 + [3x - 2(1 + 5x)]$

44. $2 + [9x - 4(3x + 2)]$

45. $8x - [2x + 4(x - 3) - 5]$

46. $17 - [-3x + 6(2x - 3) + 9]$

47. $3x^3 - [5 - 7(x^2 + 2) - 6x^2]$

48. $10x^3 - [8 - 5(3 - 2x^2) - 7x^2]$

49. $(2x^2 + 4) - [-8 + 2(7 - 3x^2) + x]$

50. $-[6x^2 - 3(4 + 2x) + 9] - (x^2 + 5)$

51. $2[3x + (x - 8) - (2x + 5)] - (x - 7)$

52. $3[x + (10 - 3x) - (8 - 3x)] + (2x - 1)$

53. $(x^2 - 1) + 2[4 + (3 - x)]$

54. $(4 - x^2) + 3[(2x - 3) - 5]$

55. $-(x - 5) + [6x - 2(4 - x)]$

56. $2(2x + 1) - [5x - (2x + 3)]$

Complete the following word problems.

57. Find the sum of $4x^2 - 3x$ and $6x + 5$.

58. Subtract $2x^2 - 4x$ from $7x^3 + 5x$.

59. Subtract $3(x + 1)$ from $5(2x - 3)$.

60. Find the sum of $10x - 2(3x + 5)$ and $3(x - 4) + 16$.

61. Subtract $3x^2 - 4x + 2$ from the sum of $4x^2 + x - 1$ and $6x - 5$.

62. Subtract $-2x^2 + 6x + 12$ from the sum of $2x^2 + 3x - 1$ and $x^2 - 13x + 2$.

63. Add $5x^3 - 8x + 1$ to the difference between $2x^3 + 14x - 3$ and $x^2 + 6x + 5$.

64. Add $2x^3 + 4x^2 + 1$ to the difference between $-x^2 + 10x - 3$ and $x^3 + 2x^2 + 4x$.

Applications

Solve.

65. A manufacturer estimates that it costs $2x^3 + 4x^2 - 35$ dollars to create the amount of items it would take to fill a box which has a side length of x feet. The warehouse manager determines it will cost $1.50x^3 + 5$ dollars to store each box for one month.
- Add the two polynomials to determine the manufacturing and storage costs for each box of items for one month.
 - The warehouse manager knows that each box will be stored for an average of 3 months. Determine the cost to produce a box of items and store it for 3 months.
 - If the box has a side length of 4 feet, use the expression from part b. to determine how much will it cost to create and store a box of items for 3 months.

66. Carson has two loans, a loan for his car and a home equity loan that he used for home improvements. The car loan is for \$15,000 and Carson plans to make monthly payments of \$500 per month. The home improvement loan is for \$9000 and Carson plans to make monthly payments of \$300.
- Write an algebraic expression to describe the value of the car loan after x months.
 - Write an algebraic expression to describe the value of the home equity loan after x months.
 - Add together the two algebraic expressions to determine the remaining loan amount to be paid after x months for both loans combined.
 - How much will Carson still owe on both loans after 10 months?
67. A company estimates that the revenue from selling x items is $58x$ dollars and the cost of producing x items is $31x + 40$ dollars.
- The company's profit is defined as revenue minus cost. Find the expression that models the profit of producing and selling x items.
 - What is the profit from producing and selling 12 items?
68. Keri's gym membership costs \$30 a month plus \$6 for every class she takes. To cut back on her spending, she is thinking of switching to a gym that costs \$20 a month plus \$4 for every class she takes.
- Write an algebraic expression that describes how much Keri is currently paying per month if she takes x classes.
 - Write an algebraic expression that describes how much Keri would pay per month at the new gym if she took x classes.
 - Write an algebraic expression that describes Keri's savings per month if she switches gyms.
 - How much would Keri save the first month if she switches gyms and takes 10 classes?

Writing & Thinking

69. Explain, in your own words, how to subtract one polynomial from another.
70. Give two examples that show how the sum of two binomials might not be a binomial.

Completion Example 11 Using the FOIL Method

Use the FOIL method to multiply the binomials: $(x+11)(3x-2)$

Solution

$$\begin{aligned}(x+11)(3x-2) &= x \cdot \underline{\hspace{2cm}} + x \cdot (\underline{\hspace{2cm}}) + 11 \cdot \underline{\hspace{2cm}} + 11 \cdot (\underline{\hspace{2cm}}) \\ &= \underline{\hspace{2cm}}x^2 + \underline{\hspace{2cm}}x - \underline{\hspace{2cm}}\end{aligned}$$

11. Use the FOIL method to multiply the binomials:

$$(2x-8)(5x-9)$$

Now work margin exercise 11.**Completion Example Answers**

2. $3x^2 \cdot x^2 + 3x^2 \cdot 12x + 3x^2(-5) = 3x^4 + 36x^3 - 15x^2$

4. $3x \cdot (5x+4) + 8 \cdot (5x+4) = 3x \cdot 5x + 3x \cdot 4 + 8 \cdot 5x + 8 \cdot 4$
 $= 15x^2 + 12x + 40x + 32 = 15x^2 + 52x + 32$

11. $x \cdot 3x + x \cdot (-2) + 11 \cdot 3x + 11 \cdot (-2) = 3x^2 + 31x - 22$

Margin Exercise Answers

1. $-18x^3 + 6x^2 + 18x$ 2. $30x^7 - 15x^5 + 60x^3$ 3. $12x^2 + 3x - 9$ 4. $7x^2 - 23x - 20$
 5. $12x^3 + 28x^2 + 2x - 2$ 6. $x^4 - 16x^2 + 16x - 4$ 7. $12x^3 + 27x^2 + 6x$ 8. $x^3 - 5x^2 - 12x + 36$
 9. $3x^2 + 25x + 28$ 10. $8x^2 - 18x + 10$ 11. $10x^2 - 58x + 72$

7.6 Exercises

Concept Check

Fill-in-the-Blank. Complete each sentence using information found in this section.

- The _____ property is used to find the product of a monomial with a polynomial.
- When multiplying two polynomials, the distributive property is applied by multiplying each ____ of one polynomial by each ____ of the other.
- In the case of the product of two binomials, a mnemonic device called the ____ method is useful.
- The FOIL method stands for First, _____, Inside, _____.
- When multiplying polynomials, the last step is to combine ____ terms, if possible.

True/False. Determine whether each statement is true or false. If a statement is false, explain how it can be changed so the statement will be true. (**Note:** There may be more than one acceptable change.)

- The distributive property can only be used to multiply a monomial and a polynomial.
- The product of $(a+b)$ and $(c+d)$ is $ac+bd$.
- The FOIL method is a way to remember one specific order that the distributive property can be applied.

Practice

Multiply and simplify, if necessary.

1. $-3x^2(2x^3 + 5x)$
2. $5x^2(-4x^2 + 6)$
3. $4x^5(x^2 - 3x + 1)$
4. $9x^3(2x^3 - x^2 + 5x)$
5. $-1(y^5 - 8y + 2)$
6. $-7(2y^4 + 3y^2 + 1)$
7. $-4x^3(x^5 - 2x^4 + 3x)$
8. $-2x^4(x^3 - x^2 + 2x)$
9. $5x^3(5x^2 - x + 2)$
10. $-2x^2(x^3 + 5x - 4)$
11. $a^2(a^5 + 2a^4 - 5a + 1)$
12. $7t^3(-t^3 + 5t^2 + 2t + 1)$
13. $(x + 4)(x - 3)$
14. $(x + 7)(x - 5)$
15. $(a + 6)(a - 8)$
16. $(x + 2)(x - 4)$
17. $(x - 2)(x - 1)$
18. $(x - 7)(x - 8)$
19. $3(t + 4)(t - 5)$
20. $-4(x + 6)(x - 7)$
21. $x(x + 3)(x + 8)$
22. $t(t - 4)(t - 7)$
23. $(2x + 1)(x - 4)$
24. $(3x - 1)(x + 4)$
25. $(6x - 1)(x + 3)$
26. $(8x + 15)(x + 1)$
27. $(2x + 3)(2x - 3)$
28. $(3t + 5)(3t - 5)$
29. $(4x + 1)(4x + 1)$
30. $(5x - 2)(5x - 2)$
31. $(y + 3)(y^2 - y + 4)$
32. $(2x + 1)(x^2 - 7x + 2)$
33.
$$\begin{array}{r} 3x + 7 \\ \underline{x - 5} \end{array}$$
34.
$$\begin{array}{r} 2x + 6 \\ \underline{x + 3} \end{array}$$
35.
$$\begin{array}{r} x^2 + 3x + 1 \\ \underline{5x - 9} \end{array}$$
36.
$$\begin{array}{r} 8x^2 + 3x - 2 \\ \underline{-2x + 7} \end{array}$$
37.
$$\begin{array}{r} 2x^2 + 3x + 5 \\ \underline{x^2 + 2x - 3} \end{array}$$
38.
$$\begin{array}{r} 6x^2 - x + 8 \\ \underline{2x^2 + 5x + 6} \end{array}$$
39. $(3x - 4)(x + 2)$
40. $(t + 6)(4t - 7)$
41. $(2x + 5)(x - 1)$
42. $(5a - 3)(a + 4)$
43. $(7x + 1)(x - 2)$
44. $(x - 2)(3x + 8)$
45. $(2x + 1)(3x - 8)$
46. $(3x + 7)(2x - 5)$

47. $(2x+3)(2x+3)$
48. $(5y+2)(5y+2)$
49. $(x+3)(x^2-4)$
50. $(y^2+2)(y-4)$
51. $(2x+7)(2x-7)$
52. $(3x-4)(3x+4)$
53. $(x+1)(x^2-x+1)$
54. $(x-2)(x^2+2x+4)$
55. $(7a-2)(7a-2)$
56. $(5a-6)(5a-6)$
57. $x(x+3)(x+5)$
58. $x(x-8)(x+2)$
59. $2x(x-1)(3x+2)$
60. $3x(x+1)(2x+3)$
61. $(2x+3)(x^2-x-1)$
62. $(3x+1)(x^2-x+9)$
63. $(x+1)(x+2)(x+3)$
64. $(t-1)(t-2)(t-3)$
65. $(a^2+a-1)(a^2-a+1)$
66. $(y^2+y+2)(y^2+y-2)$
67. $(t^2+3t+2)^2$
68. $(a^2-4a+1)^2$

Simplify.

69. $3x(2x+1)-2(2x+1)$
70. $x(3x+4)+7(3x+4)$
71. $3a(3a-5)+5(3a-5)$
72. $6x(x-1)+5(x-1)$
73. $5x(-2x+7)-2(-2x+7)$
74. $y(y^2+1)-1(y^2+1)$
75. $x(x^2+3x+2)+2(x^2+3x+2)$
76. $4x(x^2-x+1)+3(x^2-x+1)$
77. $(y+6)(y-6)+(y+5)(y-5)$
78. $(y-2)(y+2)+(y-1)(y+1)$
79. $(2a+1)(a-5)+(a-4)(a-4)$
80. $(x+4)(2x+1)+(x-3)(x-2)$
81. $(x-3)(x+5)-(x+3)(x+2)$
82. $(t+3)(t+3)-(t-2)(t-2)$
83. $(2a+3)(a+1)-(a-2)(a-2)$
84. $(4t-3)(t+4)-(t-2)(3t+1)$

Applications

Solve.

85. A graphic artist is designing a poster to advertise an upcoming event. The only restrictions regarding the poster size is that it must have a length of $3x$ inches and a width of $2x + 5$ inches. Find a simplified expression for the area of the poster.
86. Armon works for a company that ships artwork worldwide. The size of each item varies, but all of the art is on square canvases. Armon's job is to make the wooden shipping crates for each piece of art. In order to protect the artwork, each crate must be 10 inches deep. The crate must also be 10 inches wider and 12 inches taller than the artwork. Letting x represent the length of one side of the artwork, find the volume of the rectangular shipping crate.

- 87.** Theodore and Sarah have a small business selling custom-made T-shirts. They currently sell 150 shirts per month and charge \$10 per T-shirt. Sarah thinks they can increase their revenue by increasing their selling price, but Theodore knows from experience that each \$1 increase in price will decrease the number of T-shirts they sell by 8 shirts per month. Find an expression for the total monthly revenue Theodore and Sarah's business can generate if they change the selling price of their T-shirts. Let x represent number of \$1 increases in the price of the T-shirts.
- 88.** The smallest plot of land that you can rent at a community garden is 3 feet long by 4 feet wide.
- Suppose you want to rent a plot of land that is x feet longer than the smallest available plot. What would the area of this plot of land be?
 - Suppose you want to rent a plot of land that is x feet wider than the smallest plot with a length of 3 feet. What would the area of this plot of land be?
 - Suppose you want to rent a plot of land that is x feet longer and x feet wider than the smallest plot of land. What would the area of this plot of land be?
- 89.** Lee is making a box. He starts with a piece of cardboard that is 14 inches by 20 inches. He cuts a square with side length x from each corner of the box.

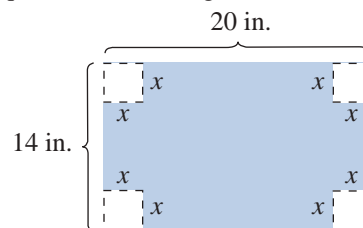

- Write a polynomial function $A(x)$ to represent the area of the cardboard that remains after the corners are cut out.
 - When the sides of the box are folded up, what will be the side lengths of the base of the box?
 - Write a polynomial function $B(x)$ to represent the area of the base of the box when the sides are folded up.
 - The height of the box will be x inches. Write a polynomial function $V(x)$ to determine the volume of the box.
- 90.** The glass portion of a sliding glass door has a ratio of height to width of 2 : 1. The framework around the window adds 8 inches to the width of the door and 10 inches to the height.
- Write a polynomial expression to represent the width of the door, including the framework. Use the variable x to represent the width of the door.
 - Write a polynomial expression to represent the height of the door, including the framework.
 - Write a polynomial expression for the total area of the window, including the framework.

Writing & Thinking

91. We have seen how the distributive property is used to multiply polynomials.

- a. Show how the distributive property can be used to find the following product.

$$\begin{array}{r} 75 \\ \times 93 \\ \hline \end{array}$$

(Hint: $75 = 70 + 5$ and $93 = 90 + 3$)

- b. In the multiplication algorithm for multiplying whole numbers (as in the product above), we are told to “move to the left” when multiplying. For example:

$$\begin{array}{r} 75 \\ \times 93 \\ \hline 15 \\ 21 \\ 45 \\ \hline 63 \end{array}$$

Why are the 21 and 45 moved one place to the left in the alignment?

When 9 and 7 are multiplied, we move the 63 two places left. Why?

Completion Example Answers

$$2. (4x)^2 - (9)^2 = 16x^2 - 81 \quad 4. (3x)^2 + 2 \cdot 10 \cdot 3x + (10)^2 = 9x^2 + 60x + 100$$

Margin Exercise Answers

$$1. \text{ a. } x^2 - 36 \quad \text{ b. } 16y^2 - 9 \quad \text{ c. } x^8 - 9 \quad 2. 4x^4 - 36 \quad 3. \text{ a. } 9x^2 + 30x + 25 \quad \text{ b. } 16x^2 - 16x + 4$$

$$\text{ c. } 4x^2 - 32x + 64 \quad \text{ d. } 4y^6 - 8y^3 + 4 \quad 4. 25x^2 - 20x + 4$$

7.7 Exercises

Concept Check

Fill-in-the-Blank. Complete each sentence using information found in this section.

- When two binomials are in the form of the sum and difference of the same term, the product is called the _____ of two squares.
- When the two binomials being multiplied together are the same, that product is called the _____ of a binomial.
- The result of squaring a binomial is a/an _____.
- Trinomials that are the result of squaring binomials are called _____ square trinomials.

True/False. Determine whether each statement is true or false. If a statement is false, explain how it can be changed so the statement will be true. (**Note:** There may be more than one acceptable change.)

- When two binomials are in the form of the sum and difference of the same term, the product will be a trinomial.
- When the two binomials being multiplied together are the same, the product will be a trinomial.
- Perfect square trinomials result from squaring a binomial sum or a binomial difference.
- When finding the product of two binomials that are in the form of the sum and difference of the same two terms, the FOIL method and the difference of two squares formula will produce different results.

Practice

Find each product and identify any that are either the difference of two squares or a perfect square trinomial. See Examples 1 through 4.

- | | | |
|-----------------|--------------------|--------------------|
| 1. $(x-7)^2$ | 6. $(x-6)(x+6)$ | 11. $(3x-4)^2$ |
| 2. $(x-5)^2$ | 7. $(x+9)(x-9)$ | 12. $(3x+1)^2$ |
| 3. $(x+4)(x+4)$ | 8. $(x+12)(x-12)$ | 13. $(5x+2)(5x-2)$ |
| 4. $(x+8)(x+8)$ | 9. $(2x+3)(x-1)$ | 14. $(2x+1)(2x-1)$ |
| 5. $(x+3)(x-3)$ | 10. $(3x+1)(2x+5)$ | 15. $(3x-2)(3x-2)$ |

16. $(3+x)^2$ 24. $(3x+7)^2$
 17. $(8-x)(8-x)$ 25. $(2x+7)(2x-7)$
 18. $(5-x)(5-x)$ 26. $(6x+5)(6x-5)$
 19. $(4x+5)(4x-5)$ 27. $(5x^2+2)(2x^2-3)$
 20. $(11-x)(11+x)$ 28. $(4x^2+7)(2x^2+1)$
 21. $(5x-9)(5x+9)$ 29. $(1+7x)^2$
 22. $(9x+2)(9x-2)$ 30. $(2-5x)^2$
 23. $(4-x)^2$

Find each product.

31. $(5+x)(5+x)$ 39. $(3x+2)(3x-2)$
 32. $(3-x)(3-x)$ 40. $(3x-1)(3x+1)$
 33. $(x^2+1)(x^2-1)$ 41. $(4x+3)(4x-3)$
 34. $(x^2+5)(x^2-5)$ 42. $(8x+5)(8x-5)$
 35. $(x^2+3)(x^2+3)$ 43. $(5x+3)(5x+3)$
 36. $(x^3+8)(x^3+8)$ 44. $(3x+4)(3x+4)$
 37. $(x^3-2)^2$ 45. $(6x-5)^2$
 38. $(x^2-4)^2$ 46. $(7x-2)^2$

 Use a calculator as an aid in multiplying the binomials.

47. $(x+1.4)(x-1.4)$ 54. $(x-1.45)^2$
 48. $(x-2.1)(x+2.1)$ 55. $(1.42x+9.6)^2$
 49. $(x-2.5)^2$ 56. $(0.46x-0.71)^2$
 50. $(x+1.7)^2$ 57. $(11.4x+3.5)(11.4x-3.5)$
 51. $(x+2.15)(x-2.15)$ 58. $(2.5x+11.4)(1.3x-16.9)$
 52. $(x+1.36)(x-1.36)$ 59. $(12.6x-6.8)(7.4x+15.3)$
 53. $(x+1.24)^2$ 60. $(3.4x+6)(3.4x-6)$

Applications

Solve.

61. A square is 30 inches on each side. A square that is x inches on each side is cut from each corner of the 30-inch square.
- Represent the area of the remaining portion of the square in the form of a polynomial function $A(x)$.
 - Represent the perimeter of the remaining portion of the square in the form of a polynomial function $P(x)$.

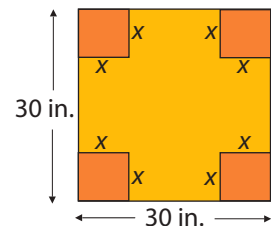

62. A rectangle has sides $(x+3)$ feet and $(x+5)$ feet. If a square that is x feet on each side is cut from the rectangle, represent the remaining area in the form of a polynomial function $A(x)$.

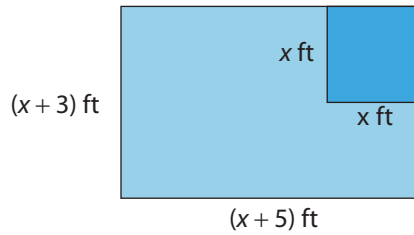

63. In the case of binomial probabilities, if x is the probability of success in one trial of an event, then the expression $f(x) = 15x^4(1-x)^2$ is the probability of 4 successes in 6 trials where $0 \leq x \leq 1$.

- Represent the expression $f(x)$ as a single polynomial by multiplying the polynomials.
 - If a fair coin is tossed, the probability of heads occurring is $\frac{1}{2}$. That is, $x = \frac{1}{2}$. Find the probability of 4 heads occurring in 6 tosses.
64. The Americans with Disabilities Act requires sidewalks to be x feet wide in order for wheelchairs to fit on them. At the bottom, the Empire State Building is 425 feet long and 190 feet wide and a regulation sidewalk surrounds the building.

- Represent the area covered by the building and the sidewalk in the form of a polynomial function.
- Represent the area covered by just the sidewalk in the form of a polynomial function.

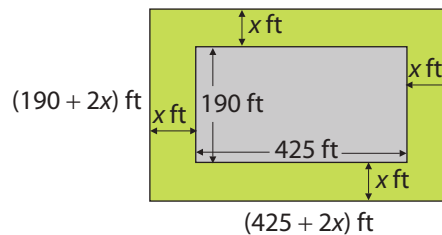

65. A rectangular piece of cardboard that is 10 inches by 15 inches has squares of length x inches on a side cut from each corner. (Assume that $0 < x < 5$.)

- Represent the remaining area in the form of a polynomial function $A(x)$.
- Represent the perimeter of the remaining figure in the form of a polynomial function $P(x)$.
- If the flaps of the cardboard are folded up, an open box is formed. Represent the volume of this box in the form of a polynomial function $V(x)$. (**Note:** Volume = length \times width \times height.)

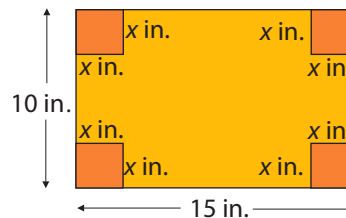

66. The world's largest single aquarium habitat, located at the Georgia Aquarium, is 284 feet long, 126 feet wide, and 30 feet deep. Another aquarium is attempting to make a tank that is x feet longer, wider, and deeper. Represent the volume of the new tank as a polynomial function $V(x)$. (**Note:** The volume of the aquarium is the product of its length, width, and height, $V = lwh$.)

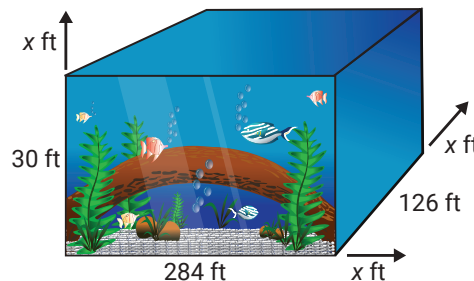

67. Lee is making a box. He starts with a piece of cardboard that is 20 inches by 20 inches. He cuts a square with side length x from each corner of the box.

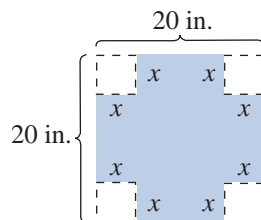

- Write a polynomial function $A(x)$ to represent the area of the cardboard that remains after the corners are cut out.
- When the sides of the box are folded up, what will be the side lengths of the base of the box?
- Write a polynomial function $B(x)$ to represent the area of the base of the box when the sides are folded up.
- The height of the box will be x inches. Write a polynomial function $V(x)$ to determine the volume of the box.

Writing & Thinking

68. A square with sides of length $(x+5)$ can be broken up as shown in the diagram. The sums of the areas of the interior rectangles and squares is equal to the total area of the square: $(x+5)^2$. Show how this fits with the formula for the square of a sum.

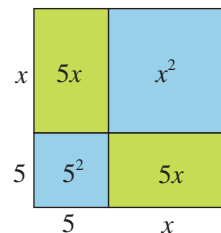

Example 4 Using Long Division (Terms Missing)

Simplify $\frac{x^4 + 9x^2 - 3x + 5}{x^2 - x + 2}$ using the division algorithm.

Solution

Note that 0 is written as a placeholder for any missing powers of the variable. In this way, like terms are easily aligned vertically.

$$\begin{array}{r}
 \overline{) x^4 + 0x^3 + 9x^2 - 3x + 5} \\
 \underline{-(x^4 - x^3 + 2x^2)} \\
 \overline{) x^3 + 7x^2 - 3x + 5} \\
 \underline{-(x^3 - x^2 + 2x)} \\
 \overline{) 8x^2 - 5x + 5} \\
 \underline{-(8x^2 - 8x + 16)} \\
 \overline{) 3x - 11}
 \end{array}$$

Note that the remainder is of smaller degree than the divisor.

Thus, the quotient is $x^2 + x + 8$ and the remainder is $3x - 11$.

In the form $Q + \frac{R}{D}$, we can write $x^2 + x + 8 + \frac{3x - 11}{x^2 - x + 2}$.

Now work margin exercise 4.**Margin Exercise Answers**

1. a. $6x^4 - 2x^3 + 3$ b. $\frac{5y^3}{2} - 3y^2 - 4$ 2. $3x^2 - x - 1 - \frac{7}{6x + 4}$ 3. $2x^2 - 3x + 9$

4. $7x^2 + 14x + 32 + \frac{55}{x - 2}$

7.8 Exercises

Concept Check

Fill-in-the-Blank. Complete each sentence using information found in this section.

- Fractions in which the numerator and denominator are polynomials are called _____ expressions.
- When polynomials are divided, if the remainder is 0, then both the divisor and quotient are _____ of the dividend.
- To divide a polynomial by a monomial, divide each term in the _____ by the monomial denominator and then _____ each fraction.

4. The division algorithm with polynomials tells us that for $\frac{P}{D} = Q + \frac{R}{D}$, where P is the _____, D is the _____, Q is the quotient, and R is the remainder.
5. When dividing polynomials, the denominator (or divisor) can never equal _____.

True/False. Determine whether each statement is true or false. If a statement is false, explain how it can be changed so the statement will be true. (**Note:** There may be more than one acceptable change.)

6. When dividing polynomials, any remainder must be of smaller degree than the divisor.
7. The first step in the division algorithm is to align the polynomials in ascending order.
8. To aid in organization and clarity when dividing polynomials, it is best to fill in any missing powers with ones.
9. The process followed when dividing two polynomials is called the division algorithm with polynomials.

Practice

Express each quotient as a sum (or difference) of fractions and simplify, if possible. See Example 1.

1. $\frac{8y^3 - 16y^2 + 24y}{8y}$

2. $\frac{18x^4 + 24x^3 + 36x^2}{6x^2}$

3. $\frac{34x^5 - 51x^4 + 17x^3}{17x^3}$

4. $\frac{14y^4 + 28y^3 + 12y^2}{2y^2}$

5. $\frac{110x^4 - 121x^3 + 11x^2}{11x}$

6. $\frac{15x^7 + 30x^6 - 45x^3}{15x^3}$

7. $\frac{-56x^4 + 98x^3 - 35x^2}{14x^2}$

8. $\frac{108x^6 - 72x^5 + 63x^4}{18x^4}$

9. $\frac{16y^6 - 56y^5 - 120y^4 + 64y^3}{16y^3}$

10. $\frac{20y^5 - 14y^4 + 21y^3 + 42y^2}{4y^2}$

Divide by using the division algorithm. Write the answers in the form $Q + \frac{R}{D}$, where the degree of R is less than the degree of D . See Examples 2 through 4.

11. $\frac{x^2 - 2x - 20}{x + 4}$

12. $\frac{x^2 + 9x - 5}{x - 1}$

13. $\frac{6x^2 - 11x - 3}{2x - 1}$

14. $\frac{10x^2 + 16x + 5}{5x + 3}$

15. $\frac{21x^2 + 25x - 3}{7x - 1}$

16. $\frac{15x^2 - 14x - 11}{3x - 4}$

17.
$$\frac{x^2 - 12x + 27}{x - 3}$$

18.
$$\frac{x^2 - 12x + 35}{x - 5}$$

19.
$$\frac{x^3 - 9x^2 + 8x - 3}{x - 8}$$

20.
$$\frac{x^3 - 6x^2 + 8x - 5}{x - 2}$$

21.
$$\frac{4x^3 + 2x^2 - 3x + 1}{x + 2}$$

22.
$$\frac{3x^3 + 6x^2 + 8x - 5}{x + 1}$$

23.
$$\frac{x^3 + 6x + 3}{x - 7}$$

24.
$$\frac{2x^3 + 3x - 2}{x - 1}$$

25.
$$\frac{2x^3 - 5x^2 + 6}{x + 2}$$

26.
$$\frac{4x^3 - x^2 + 13}{x - 1}$$

27.
$$\frac{21x^3 + 41x^2 + 13x + 5}{3x + 5}$$

28.
$$\frac{6x^3 - 7x^2 + 14x - 8}{3x - 2}$$

29.
$$\frac{2x^3 + 7x^2 + 10x - 6}{2x + 3}$$

30.
$$\frac{6x^3 - 4x^2 + 5x - 7}{x - 2}$$

31.
$$\frac{x^3 - x^2 - 10x - 10}{x - 4}$$

32.
$$\frac{2x^3 - 3x^2 + 7x + 4}{2x - 1}$$

33.
$$\frac{10x^3 + 11x^2 - 12x + 9}{5x + 3}$$

34.
$$\frac{6x^3 + 19x^2 - 3x - 7}{6x + 1}$$

35.
$$\frac{2x^3 - 7x + 2}{x + 4}$$

36.
$$\frac{2x^3 + 4x^2 - 9}{x + 3}$$

37.
$$\frac{9x^3 - 19x + 9}{3x - 2}$$

38.
$$\frac{4x^3 - 8x^2 - 9x}{2x - 3}$$

39.
$$\frac{6x^3 + 11x^2 + 25}{2x + 5}$$

40.
$$\frac{16x^3 + 7x + 12}{4x + 3}$$

41.
$$\frac{x^4 - 3x^3 + 2x^2 - x + 2}{x - 3}$$

42.
$$\frac{x^4 + x^3 - 4x^2 + x - 3}{x + 6}$$

43.
$$\frac{x^4 + 2x^2 - 3x + 5}{x - 2}$$

44.
$$\frac{3x^4 + 2x^3 - 2x^2 - 1}{x + 1}$$

45.
$$\frac{x^4 - x^2 + 3}{x - \frac{1}{2}}$$

46.
$$\frac{x^3 + 2x^2 + 1}{x - \frac{2}{3}}$$

47.
$$\frac{3x^3 + 5x^2 + 7x + 9}{x^2 + 2}$$

48.
$$\frac{2x^4 + 2x^3 + 3x^2 + 6x - 1}{2x^2 + 3}$$

49.
$$\frac{x^4 + x^3 - 4x + 1}{x^2 + 4}$$

50.
$$\frac{2x^4 + x^3 - 8x^2 + 3x - 2}{x^2 - 5}$$

51.
$$\frac{6x^3 + 5x^2 - 8x + 3}{3x^2 - 2x - 1}$$

52.
$$\frac{x^3 - 9x^2 + 20x - 38}{x^2 - 3x + 5}$$

53.
$$\frac{3x^4 - 7x^3 + 5x^2 + x - 2}{x^2 + x + 1}$$

54.
$$\frac{2x^4 - x^3 - 10x^2 - 3x - 1}{x^2 - 3x + 1}$$

55.
$$\frac{x^4 + 3x - 7}{x^2 + 2x - 3}$$

56.
$$\frac{3x^4 - 4x^2 + 3}{x^2 + x - 1}$$

57.
$$\frac{x^3 - 27}{x - 3}$$

58.
$$\frac{x^3 + 125}{x + 5}$$

59.
$$\frac{x^6 - 1}{x + 1}$$

60.
$$\frac{x^6 - 1}{x - 1}$$

61.
$$\frac{x^5 + 1}{x - 1}$$

62.
$$\frac{x^6 + 1}{x + 1}$$

63.
$$\frac{x^5 - x^3 + x}{x + \frac{1}{2}}$$

64.
$$\frac{x^4 - 2x^3 + 4}{x + \frac{4}{5}}$$

Applications

Solve.

-
65. A moving company uses a box that has a volume of $x^3 - 2x^2 - 13x - 10$ cubic inches.
- If the height of the box is $x + 2$, what is the area of the base of the box?
 - If the height of the box is $x + 1$, what is the area of the base of the box?
66. A rectangular garden requires a volume of top soil modeled by the equation $200x^3 + 350x^2 + 150x$, where x is the depth in inches of top soil needed.
- Determine an expression for the area of the garden.
(**Hint:** Volume = length · width · height and Area = length · width.)
 - If the width of the garden is $10x + 10$ inches, use the expression from part a. to find an expression for the length of the garden.
 - If the depth of soil needed is 3 inches, find the volume of top soil that needs to be purchased for the garden.
 - Determine how many cubic feet of top soil is needed by dividing the answer from part c. by 1728 in.^3 . Round your answer to the nearest tenth.
(**Note:** $1 \text{ cubic foot} = 12 \text{ in.} \cdot 12 \text{ in.} \cdot 12 \text{ in.} = 1728 \text{ in.}^3$)
 - If the top soil comes in bags that contain 0.75 cubic feet of soil, how many bags will need to be purchased?
 - If the cost of the top soil is \$2.10 per bag (including tax), what will be the total cost of the top soil needed for the garden?

Writing & Thinking

67. Suppose that a polynomial is divided by $(3x-2)$ and the answer is given as

$$x^2 + 2x + 4 + \frac{20}{3x-2}.$$

What was the original polynomial? Explain how you arrived at this conclusion.

68. Suppose that a polynomial is divided by $(x+5)$ and the answer is given as

$$x^2 - 3x + 2 - \frac{6}{x+5}.$$

What was the original polynomial? Explain how you arrived at this conclusion.

69. Given that $P(x) = 2x^3 - 8x^2 + 10x + 15$.

- Find $P(2)$ then divide $P(x)$ by $x-2$.
- Find $P(-1)$ then divide $P(x)$ by $x+1$.
- Find $P(4)$ then divide $P(x)$ by $x-4$.

Do you see any pattern in the values of $P(a)$ for $x=a$ and the remainders you found in the division process?

$$\begin{aligned}
 5xy + 6uv - 3vy - 10ux &= (5xy - 3vy) + (6uv - 10ux) \\
 &= y(5x - 3v) - 2u(-3v + 5x) \\
 &= y(5x - 3v) - 2u(5x - 3v) && \text{Note: } 5x - 3v = -3v + 5x \\
 &= (5x - 3v)(y - 2u)
 \end{aligned}$$

Now work margin exercise 11.

Margin Exercise Answers

1. a. 5 b. $50xy$ 2. a. $7(n+3)$ b. $y^3(3+y)$ c. $9x(1+6x)$ 3. Not factorable
 4. $-9a(a^2+2-a)$ 5. a. $10xy(1+3y)$ b. $2ab^2(a-8)$ c. $5xz(z+3z^2-4x)$
 d. $-3b^2(d-4+5bd^2)$ 6. a. $(2x-y)(x^2+2)$ b. $(x-u)(6y+1)$ 7. $(x+2)(y+6)$
 8. $(x-3)(y-2)$ 9. Not factorable 10. $(x+y)(x+1)$ 11. $(4x-3w)(2y-3z)$

8.1 Exercises

Concept Check

Fill-in-the-Blank. Complete each sentence using information found in this section.

- The result of multiplication is called the _____ and the numbers or expressions being multiplied are called _____ of the product.
- The reverse of multiplication with polynomials is called _____.
- GCF stands for _____. The GCF of a set of numbers is the _____ positive integer that is a factor of all numbers in the set.
- Factoring polynomials with four or more terms can sometimes be accomplished by _____ terms and using the distributive property.
- If the leading coefficient in a polynomial is a negative number, you may choose to factor out the _____ of the GCF.

True/False. Determine whether each statement is true or false. If a statement is false, explain how it can be changed so the statement will be true. (**Note:** There may be more than one acceptable change.)

- When finding the GCF of a polynomial, you need to consider only the coefficients.
- An expression is factored completely if none of its factors can be factored.
- One way to find the GCF of a set of numbers is to use the prime factorization of each number.
- Binomials cannot be factored out of algebraic expressions.

Practice

Find the GCF for each set of terms. See Example 1.

- | | |
|-----------------------|---|
| 1. $\{10, 15, 20\}$ | 9. $\{8a^3, 16a^4, 20a^2\}$ |
| 2. $\{25, 30, 75\}$ | 10. $\{36xy, 48xy, 60xy\}$ |
| 3. $\{16, 40, 56\}$ | 11. $\{26ab^2, 39a^2b, 52a^2b^2\}$ |
| 4. $\{30, 42, 54\}$ | 12. $\{28c^2d^3, 14c^3d^2, 42cd^2\}$ |
| 5. $\{9, 14, 22\}$ | 13. $\{45x^2y^2z^2, 75xy^2z^3\}$ |
| 6. $\{44, 66, 88\}$ | 14. $\{21a^5b^4c^3, 28a^3b^4c^3, 35a^3b^4c^2\}$ |
| 7. $\{30x^3, 40x^5\}$ | |
| 8. $\{15y^4, 25y\}$ | |

Simplify each expression.

- | | |
|--------------------------|-------------------------------|
| 15. $\frac{x^7}{x^3}$ | 19. $\frac{9x^5}{3x^2}$ |
| 16. $\frac{x^8}{x^3}$ | 20. $\frac{-10x^5}{2x}$ |
| 17. $\frac{-8y^3}{2y^2}$ | 21. $\frac{4x^3y^2}{2xy}$ |
| 18. $\frac{12x^2}{2x}$ | 22. $\frac{21x^4y^3}{-3xy^2}$ |

Complete the factoring of the polynomial as indicated.

- | | |
|----------------------------------|--|
| 23. $3m + 27 = 3(\quad)$ | 27. $13ab^2 + 13ab = 13ab(\quad)$ |
| 24. $2x + 18 = 2(\quad)$ | 28. $8x^2y - 4xy = 4xy(\quad)$ |
| 25. $5x^2 - 30x = 5x(\quad)$ | 29. $-15xy^2 - 20x^2y - 5xy = -5xy(\quad)$ |
| 26. $6y^3 - 24y^2 = 6y^2(\quad)$ | 30. $-9m^3 - 3m^2 - 6m = -3m(\quad)$ |

Factor each polynomial by finding the GCF (or $-1 \cdot \text{GCF}$). See Examples 2 through 5.

- | | |
|---------------------|--------------------------|
| 31. $11x - 121$ | 38. $16x^4y - 14x^2y$ |
| 32. $14x + 21$ | 39. $-18y^2z^2 + 2yz$ |
| 33. $16y^3 + 12y$ | 40. $-14x^2y^3 - 14x^2y$ |
| 34. $-3x^2 + 6x$ | 41. $8y^2 - 32y + 8$ |
| 35. $-6ax + 9ay$ | 42. $5x^2 - 15x - 5$ |
| 36. $4ax - 8ay$ | 43. $2xy^2 - 3xy - x$ |
| 37. $10x^2y - 25xy$ | 44. $ad^2 + 10ad + 25a$ |

- | | |
|---------------------------------------|--------------------------------------|
| 45. $8m^2x^3 - 12m^2y + 4m^2z$ | 48. $34x^4y^6 - 51x^3y^5 + 17x^5y^4$ |
| 46. $36t^2x^4 - 45t^2x^3 + 24t^2x^2$ | 49. $15x^4y^2 + 24x^6y^6 - 32x^7y^3$ |
| 47. $-56x^4z^3 - 98x^3z^4 - 35x^2z^5$ | 50. $-3x^2y^4 - 6x^3y^4 - 9x^2y^3$ |

Factor each expression by factoring out the common binomial factor. See Example 6.

- | | |
|--------------------------|---------------------------|
| 51. $7y^2(y+3) + 2(y+3)$ | 56. $9a(x+1) - (x+1)$ |
| 52. $6a(a-7) - 5(a-7)$ | 57. $10y(2y+3) - 7(2y+3)$ |
| 53. $3x(x-4) + (x-4)$ | 58. $a(x+5) + b(x+5)$ |
| 54. $2x^2(x+5) + (x+5)$ | 59. $a(x-2) - b(x-2)$ |
| 55. $4x^3(x-2) - (x-2)$ | 60. $3a(x-10) + 5b(x-10)$ |

Factor each of the polynomials by grouping. If a polynomial cannot be factored, write "not factorable." See Examples 7 through 11.

- | | |
|------------------------------|--------------------------------|
| 61. $bx + b + cx + c$ | 73. $6ax + 12x + a + 2$ |
| 62. $3x + 3y + ax + ay$ | 74. $4xy + 3x - 4y - 3$ |
| 63. $x^3 + 3x^2 + 6x + 18$ | 75. $xy + x + y + 1$ |
| 64. $2z^3 - 14z^2 + 3z - 21$ | 76. $xy + x - y - 1$ |
| 65. $10a^2 - 5az + 2a + z$ | 77. $10xy - 2y^2 + 7yz - 35xz$ |
| 66. $x^2 - 4x + 6xy - 24y$ | 78. $7xy - 3y + 2x^2 - 3x$ |
| 67. $3x + 3y - bx - by$ | 79. $3xy - 4uy - 6vx + 8uv$ |
| 68. $ax + 5ay + 3x + 15y$ | 80. $xy + 5vy + 6ux + 30uv$ |
| 69. $5xy + yz - 20x - 4z$ | 81. $3ab + 4ac + 2b + 6c$ |
| 70. $x - 3xy + 2z - 6zy$ | 82. $24y - 3yz + 2xz - 16x$ |
| 71. $z^2 + 3 + az^2 + 3a$ | 83. $6ac - 9ad + 2bc - 3bd$ |
| 72. $x^2 - 5 + x^2y + 5y$ | 84. $2ac - 3bc + 6ad - 9bd$ |

Applications

Solve.

85. Bonnie volunteers to bring bags of candy to her child's class for the Halloween party this year. She buys one bag of candy A containing 150 pieces of candy, one bag of candy B containing 180 pieces of candy, and one bag of candy C containing 330 pieces of candy. She needs to use all the candy to create identical treat bags. How many treat bags can Bonnie make so that each one has the same number and variety of candy? How many of each type of candy will be in each bag?

86. The area of a rectangular photo can be represented by the polynomial $15x^2 + 5x$.
- If $x = 2$ inches, find the area of the photo.
 - Factor the polynomial to find a variable expression for the length and width of the photo.
 - If $x = 2$ inches, use the answer from part b. to find the length and the width of the photo.
 - Find the area of the photo by multiplying the length and width values from part c.
 - Are the answers from parts a. and d. the same? Explain why or why not.
87. A circus performer is shot vertically into the air with an initial velocity of 48 feet per second. The height of the performer above the ground in feet can be described by the polynomial $48x - 16x^2$ after x seconds.
- Find the height of the circus performer after 2 seconds.
 - Factor the polynomial $48x - 16x^2$.
 - Use the factored form of the polynomial from part b. to find the height of the circus performer after 2 seconds.
 - Are the answers from parts a. and c. the same? Explain why or why not.

Writing & Thinking

88. Explain why the GCF of $-3x^2 + 3$ is 3 and not -3 .

Completion Example Answers

3. $(y+8)(y+2)$ 5. $5(a^2+5a-36)=5(a+9)(a-4)$

Margin Exercise Answers

1. $(x+3)(x+7)$ 2. $(x-5)(x+4)$ 3. $(x-3)(x-2)$ 4. a. $7y(y-1)(y+6)$
b. $11xy(x+3)(x-1)$ 5. $6(x+4)(x-2)$

8.2 Exercises

Concept Check

Fill-in-the-Blank. Complete each sentence using information found in this section.

- To factor a trinomial that has 1 as its leading coefficient, find two factors of the _____ term whose sum is the coefficient of the _____ term.
- When listing all the pairs of factors for a particular term, the _____ - _____ - _____ method is being used.
- When factoring trinomials with leading coefficient 1, if the constant is _____, then both factors have the same sign.
- If the leading coefficient of a trinomial is not one, the first step in factoring is to look for a/an _____ monomial factor to factor out.
- When factoring trinomials with leading coefficient 1, if the constant term is negative, then the factors of that constant have _____ sign(s).

True/False. Determine whether each statement is true or false. If a statement is false, explain how it can be changed so the statement will be true. (**Note:** There may be more than one acceptable change.)

- In a trinomial such as $x^2 - 5x + 4$, one would need to find two factors of 4 whose sum is negative 5.
- In factoring a trinomial with leading coefficient 1, if the constant term is negative, then both factors must be negative.
- The first step in factoring a trinomial is to look for a common monomial factor.
- For a trinomial with leading coefficient 1, if no pair exists whose product is the constant and whose sum is the middle term's coefficient, then the trinomial is not factorable.

Practice

List all pairs of integer factors for each given integer. Remember to include negative integers as well as positive integers.

- | | |
|-------|-------|
| 1. 15 | 3. 20 |
| 2. 12 | 4. 30 |

5. -6

6. -7

7. 16

8. 18

9. -10

10. -25

Find the pair of integers whose product is the first integer and whose sum is the second integer.

11. 12, 7

12. 25, 26

13. -14, -5

14. -30, -1

15. -8, 7

16. -40, 6

17. 36, -12

18. 16, -10

19. 20, -9

20. 4, -5

Complete each factorization as indicated.

21. $x^2 + 6x + 5 = (x + 5)(\quad)$

22. $y^2 - 7y + 6 = (y - 1)(\quad)$

23. $p^2 - 9p - 10 = (p + 1)(\quad)$

24. $m^2 + 4m - 45 = (m - 5)(\quad)$

25. $a^2 + 12a + 36 = (a + 6)(\quad)$

26. $n^2 - 2n - 3 = (n - 3)(\quad)$

Completely factor each trinomial. If a trinomial cannot be factored, write "not factorable." See Examples 1 through 5.

27. $x^2 - x - 12$

28. $x^2 - 6x - 27$

29. $y^2 + y - 30$

30. $x^2 + 6x - 36$

31. $m^2 + 3m - 1$

32. $x^2 + 3x - 18$

33. $x^2 - 8x + 16$

34. $a^2 + 10a + 25$

35. $x^2 + 7x + 12$

36. $a^2 + a + 2$

37. $y^2 - 3y + 2$

38. $y^2 - 14y + 24$

39. $x^2 + 3x + 5$

40. $y^2 + 12y + 35$

41. $x^2 - x - 72$

42. $y^2 + 8y + 7$

43. $z^2 - 15z + 54$

44. $a^2 + 4a - 21$

45. $x^3 + 10x^2 + 21x$

46. $x^3 + 8x^2 + 15x$

47. $5x^2 - 5x - 60$

48. $6x^2 + 24x + 18$

49. $10y^3 - 10y^2 - 60y$

50. $7y^3 - 70y^2 + 168y$

51. $4p^4 + 36p^3 + 32p^2$

52. $15m^5 - 30m^4 + 15m^3$

53. $2x^4 - 14x^3 - 36x^2$

54. $3y^6 + 33y^5 + 90y^4$

55. $2x^2 - 2x - 72$

56. $3x^2 - 18x + 30$

57. $2a^4 - 8a^3 - 120a^2$ 62. $x^3 - 2x^2 - 3x$
 58. $2a^4 + 24a^3 + 54a^2$ 63. $5a^2 + 10a - 30$
 59. $3y^5 - 21y^4 - 24y^3$ 64. $6a^2 + 24a + 12$
 60. $4y^5 + 28y^4 + 24y^3$ 65. $20a^4 + 40a^3 + 20a^2$
 61. $x^3 - 10x^2 + 16x$ 66. $6x^4 - 12x^3 + 6x^2$

Applications

Solve.

67. The area of a triangle is $\frac{1}{2}$ the product of its base and its height. If the area of the triangle shown is given by the function $A(x) = \frac{1}{2}x^2 + 24x$, find representations for the lengths of its base and its height (where the base is longer than the height).

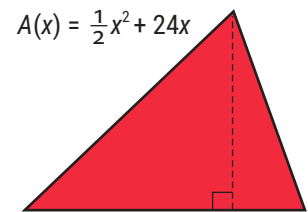

68. The area of a triangle is $\frac{1}{2}$ the product of its base and its height. If the area of the triangle shown is given by the function $A(x) = \frac{1}{2}x^2 + 14x$, find representations for the lengths of its base and its height (where the height is longer than the base).

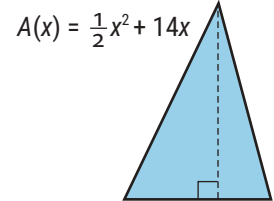

69. The area of the rectangle shown is given by the polynomial function $A(x) = 4x^2 + 20x$. If the width of the rectangle is $4x$, what is the length?

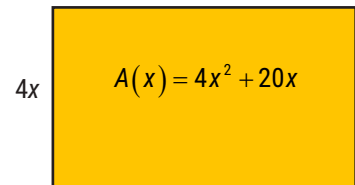

70. The area of the rectangle shown is given by the polynomial function $A(x) = x^2 + 11x + 24$. If the length of the rectangle is $(x + 8)$, what is the width?

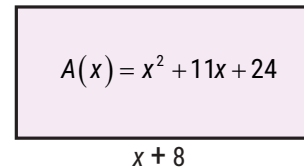

71. A ball is thrown upward from an initial height of 96 feet with an initial velocity of 16 feet per second. After t seconds, the height of the ball can be described by the polynomial $-16t^2 + 16t + 96$.
- What is the height of the ball after 3 seconds?
 - Completely factor the polynomial $-16t^2 + 16t + 96$.
 - Use the factored form of the polynomial from part b. to find the height of the ball after 3 seconds.
 - Are the answers from parts a. and c. the same? Why do you think this is?

72. A large call center determines that the average number of calls they receive per hour of the day can be modeled by the polynomial $-x^2 + 25x - 100$, where x is the hour of the day, 1 through 24.
- Factor the polynomial completely.
 - If the average number of calls at a certain time of day equals 26, write an equation using the polynomial given to demonstrate this fact.
 - Rewrite the equation in part b. so that all terms are on the left side of the equation and zero is on the right.
 - Factor the expression on the left side of the equation from part c.

Writing & Thinking

73. Discuss, in your own words, how the sign of the constant term determines what signs will be used in the factors when factoring trinomials.

Solution

- a. To begin, factor out the common monomial $2x$.

$$6x^3 - 8x^2 + 2x = 2x(3x^2 - 4x + 1)$$

Now, factor the trinomial $3x^2 - 4x + 1$. Since the middle term is $-4x$ and the constant is $+1$, we know that the two factors of 1 must both be negative, -1 and -1 . We also know that $\mathbf{F} = 3x^2 = 3x \cdot x$. This gives

$$3x^2 - 4x + 1 = (3x - 1)(x - 1). \quad -3x - x = -4x$$

Thus, $6x^3 - 8x^2 + 2x = 2x(3x^2 - 4x + 1) = 2x(3x - 1)(x - 1)$. Be careful to include the monomial term in the answer.

Check

Check the factorization by multiplying.

$$\begin{aligned} 2x(3x - 1)(x - 1) &= 2x(3x^2 - 3x - x + 1) \\ &= 2x(3x^2 - 4x + 1) \\ &= 6x^3 - 8x^2 + 2x \end{aligned}$$

The original polynomial

b. $-2x^2 - x + 6 = -1(2x^2 + x - 6)$
 $= -1(2x - 3)(x + 2)$

Notice that factoring out -1 gives a positive leading coefficient for the trinomial.

c. $10x^3 + 5x^2 + 5x = 5x(2x^2 + x + 1)$

Now consider the trinomial: $2x^2 + x + 1 = (2x + ?)(x + ?)$.

The factors of $+1$ need to be $+1$ and $+1$, but $(2x + 1)(x + 1) = 2x^2 + \underline{3x} + 1$.

So there is no way to factor and get a middle term of $+x$ for the product. This trinomial, $2x^2 + x + 1$, is **not factorable**.

We have

$$10x^3 + 5x^2 + 5x = 5x(2x^2 + x + 1). \quad \text{Factored completely}$$

Note

Remember, to *factor completely* means to find factors of the polynomial, none of which are themselves factorable. Thus,

$$2x^2 + 12x + 10 = (2x + 10)(x + 1)$$

is not factored completely because $2x + 10 = 2(x + 5)$.

We could write

$$\begin{aligned} 2x^2 + 12x + 10 &= (2x + 10)(x + 1) \\ &= 2(x + 5)(x + 1). \end{aligned}$$

This problem can be avoided by first factoring out the GCF (in this case, 2).

Now work margin exercise 2.**Margin Exercise Answers**

1. a. $(x + 6)(x + 2)$ b. $(4u - 7)(2u + 3)$ 2. a. $4x(2x - 1)(x - 1)$ b. $7x(3x^2 + 7x - 1)$

8.3 Exercises

Concept Check

Fill-in-the-Blank. Complete each sentence using information found in this section.

1. When using the trial-and-error method to factor a trinomial of the form $ax^2 + bx + c$, you first need to list all possible combinations of _____ of a and c , in their respective “First” and “Last” positions, according to the FOIL method.

2. The second step is to check the sums of the _____ in the O and I positions in the list until you find the sum to be c .
3. If none of these sums is c , the trinomial is not _____.
4. Look at the _____ term to determine what signs to use for the constants in the factors.

True/False. Determine whether each statement is true or false. If a statement is false, explain how it can be changed so the statement will be true. (**Note:** There may be more than one acceptable change.)

5. The trial-and-error method of factoring a trinomial follows the same steps as the FOIL method of multiplication.
6. Factoring can be checked by multiplying the factors and verifying that the product matches the original polynomial.

Practice

Completely factor each polynomial. If a polynomial cannot be factored, write "not factorable."

- | | | |
|-----------------------|------------------------|-----------------------------|
| 1. $x^2 + 5x + 6$ | 15. $-2x^3 + x^2 + x$ | 29. $3x^2 - 7x + 2$ |
| 2. $x^2 - 6x + 8$ | 16. $-2y^3 - 3y^2 - y$ | 30. $7x^2 - 11x - 6$ |
| 3. $2x^2 - 3x - 5$ | 17. $4t^2 - 3t - 1$ | 31. $9x^2 - 6x + 1$ |
| 4. $3x^2 - 4x - 7$ | 18. $2x^2 - 3x - 2$ | 32. $4x^2 + 4x + 1$ |
| 5. $6x^2 + 11x + 5$ | 19. $5a^2 - a - 6$ | 33. $6y^2 + 7y + 2$ |
| 6. $4x^2 - 11x + 6$ | 20. $3a^2 + 4a + 1$ | 34. $12y^2 - 7y - 12$ |
| 7. $-x^2 + 3x - 2$ | 21. $7x^2 + 5x - 2$ | 35. $x^2 - 46x + 45$ |
| 8. $-x^2 - 5x - 6$ | 22. $4x^2 + 23x + 15$ | 36. $x^2 + 6x - 16$ |
| 9. $x^2 - 3x - 10$ | 23. $8x^2 - 10x - 3$ | 37. $3x^2 + 9x + 5$ |
| 10. $x^2 - 11x + 10$ | 24. $6x^2 + 23x + 21$ | 38. $5a^2 - 7a + 2$ |
| 11. $-x^2 + 13x + 14$ | 25. $9x^2 - 3x - 20$ | 39. $12m^2n - 45mn - 12n$ |
| 12. $-x^2 + 12x - 36$ | 26. $4x^2 + 40x + 25$ | 40. $30a^3b - 28a^2b + 6ab$ |
| 13. $x^2 + 8x + 64$ | 27. $12x^2 - 38x + 20$ | 41. $x^2 + x + 1$ |
| 14. $x^2 + 2x + 3$ | 28. $12b^2 - 12b + 3$ | 42. $x^2 + 2x + 2$ |

Writing & Thinking

43. It is true that $2x^2 + 10x + 12 = (2x + 6)(x + 2) = (2x + 4)(x + 3)$. Explain how the trinomial can be factored in two ways. Is there some kind of error?
44. It is true that $5x^2 - 5x - 30 = (5x - 15)(x + 2)$. Explain why this is not the completely factored form of the trinomial.

Tips to Keep in Mind While Factoring

1. When factoring polynomials, always look for the greatest common factor first. Then, if there is one, remember to include this common factor as part of the answer.
2. **To factor completely** means to find factors of the polynomial such that none of the factors are themselves factorable.
3. Not all polynomials are factorable. Any polynomial that cannot be factored as the product of polynomials with integer coefficients is not factorable.
4. Factoring can be checked by multiplying the factors. The product should be the original expression.

4. Completely factor each trinomial. Be sure to begin by looking for the greatest common factor.

a. $5x^2 - 32x - 21$

b. $24x^2 + 87x - 36$

Note

No matter which method you use (the ac -method or the trial-and-error method), factoring trinomials takes time. With practice, you will become more efficient with either method. Make sure to be patient and observant.

Completion Example 4 Factoring Trinomials

Completely factor each trinomial. Be sure to begin by looking for the greatest common factor.

a. $15x^2 + 38x + 7$

b. $4y^2 + 6y - 108$

Solution

a. $15x^2 + 38x + 7 = (5x + \underline{\hspace{1cm}})(3x + \underline{\hspace{1cm}})$

b. $4y^2 + 6y - 108 = 2(\underline{\hspace{1cm}}y^2 + \underline{\hspace{1cm}}y - \underline{\hspace{1cm}})$
 $= 2(2y - \underline{\hspace{1cm}})(y + \underline{\hspace{1cm}})$

Now work margin exercise 4.

Completion Example Answers

4. a. $(5x + 1)(3x + 7)$ b. $2(2y^2 + 3y - 54) = 2(2y - 9)(y + 6)$

Margin Exercise Answers

1. $(3a + 2)(a + 4)$ 2. $3(b - 2)(4b + 5)$ 3. $(7x - 2)(x + 3)$ 4. a. $(5x + 3)(x - 7)$

b. $3(x + 4)(8x - 3)$

8.4 Exercises

Concept Check

Fill-in-the-Blank. Complete each sentence using information found in this section.

1. When using the ac -method of factoring, you need to find two integers whose _____ is ac and whose _____ is b .
2. The ac -method of factoring uses the _____ method.

True/False. Determine whether each statement is true or false. If a statement is false, explain how it can be changed so the statement will be true. (**Note:** There may be more than one acceptable change.)

- A trinomial is factorable if the middle term is the difference of the inner and outer products of two binomials.
- If it is not possible to find a product of two integers a and c whose sum is b , then the trinomial $ax^2 + bx + c$ is not factorable.
- The first step in the ac -method of factoring is to rewrite the middle term.

Practice

Completely factor each polynomial. If a polynomial cannot be factored, write "not factorable."

- | | |
|-----------------------------|---------------------------------|
| 1. $3x^2 + 7x - 6$ | 21. $6x^2 + 2x - 20$ |
| 2. $5x^2 - 3x - 2$ | 22. $12y^2 - 15y + 3$ |
| 3. $4x^2 + 2x - 12$ | 23. $10x^2 + 35x + 30$ |
| 4. $9x^2 - 3x - 12$ | 24. $24y^2 + 4y - 4$ |
| 5. $2x^2 + 4x + 5$ | 25. $-18x^2 + 72x - 8$ |
| 6. $3x^2 - 5x + 3$ | 26. $7x^4 - 5x^3 + 3x^2$ |
| 7. $6x^2 + 13x + 6$ | 27. $-45y^2 + 30y + 120$ |
| 8. $10x^2 + 9x + 2$ | 28. $-12m^2 + 22m + 4$ |
| 9. $-2x^2 - 11x - 5$ | 29. $12x^2 - 60x + 75$ |
| 10. $-12x^2 - 25x - 12$ | 30. $32y^2 + 50$ |
| 11. $50x^2 + 15x - 2$ | 31. $6x^3 + 9x^2 - 6x$ |
| 12. $44x^2 + 3x - 2$ | 32. $-5y^2 + 40y - 60$ |
| 13. $15x^2 - 8x + 1$ | 33. $12x^3 - 108x^2 + 243x$ |
| 14. $18x^2 - 15x + 2$ | 34. $30a^3 + 51a^2 + 9a$ |
| 15. $8a^2b - 22ab + 12b$ | 35. $9x^3y^3 + 9x^2y^3 + 9xy^3$ |
| 16. $12m^3n - 50m^2n + 8mn$ | 36. $48x^2y - 354xy + 126y$ |
| 17. $16x^2 - 8x + 1$ | 37. $48xy^3 - 100xy^2 + 48xy$ |
| 18. $3x^2 - 11x - 4$ | 38. $24a^2x^2 + 72a^2x + 243x$ |
| 19. $64x^2 - 48x + 9$ | 39. $21y^4 - 98y^3 + 56y^2$ |
| 20. $9x^2 - 12x + 4$ | 40. $72a^3 - 306a^2 + 189a$ |

Writing & Thinking

41. The volume of an open box is found by cutting equal squares (x inches on a side) from a sheet of cardboard that is 5 inches by 25 inches. The function representing this volume is $V(x) = 4x^3 - 60x^2 + 125x$, where $0 < x < 2.5$. Factor this function and use the factors to explain, in your own words, how the function represents the volume.

(**Note:** Volume of a box = length \times width \times height.)

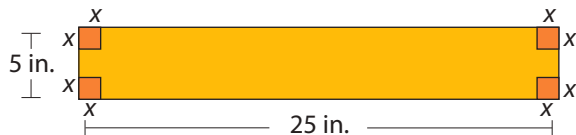

Solution

$$\begin{aligned} \text{a. } x^3 - 8 &= x^3 - 2^3 \\ &= (x - 2)(x^2 + 2 \cdot x + 2^2) \\ &= (x - 2)(x^2 + 2x + 4) \end{aligned}$$

Note: Remember that the second polynomial is not a perfect square trinomial and cannot be factored.

$$\begin{aligned} \text{b. } x^6 + 64y^3 &= (x^2)^3 + (4y)^3 \\ &= (x^2 + 4y)\left[(x^2)^2 - 4y \cdot x^2 + (4y)^2\right] \\ &= (x^2 + 4y)(x^4 - 4x^2y + 16y^2) \end{aligned}$$

c. Factor out the GCF first. Then factor the **difference of two cubes**.

$$\begin{aligned} 16y^{12} - 250 &= 2(8y^{12} - 125) \\ &= 2\left[(2y^4)^3 - 5^3\right] \\ &= 2(2y^4 - 5)\left[(2y^4)^2 + (5)(2y^4) + 5^2\right] \\ &= 2(2y^4 - 5)(4y^8 + 10y^4 + 25) \end{aligned}$$

Now work margin exercise 4.**Margin Exercise Answers**

1. a. $7a(x-7)(x+7)$ b. $(y^3+10)(y^3-10)$ 2. a. Not factorable b. $5(9x^2+4)$
 3. a. $(z+20)^2$ b. $(y-7)^2$ c. $3z(x-3y)^2$ d. $(y+4-z)(y+4+z)$
 4. a. $(y-3)(y^2+3y+9)$ b. $(2y-x^2)(4y^2+2x^2y+x^4)$ c. $6(2x^4-5)(4x^8+10x^4+25)$

8.5 Exercises

Concept Check

Fill-in-the-Blank. Complete each sentence using information found in this section.

- Factoring a perfect square trinomial gives a square _____.
- In a perfect square trinomial, both the first and last terms must be perfect _____.
- If the first term of a perfect square trinomial is x^2 , and the last term is of the form a^2 , then the middle term must be of the form _____ or _____.
- The formula for factoring the difference of cubes is $x^3 - a^3 =$ _____.
- The formula for factoring the sum of two cubes is $x^3 + a^3 =$ _____.
- The first 6 perfect cubes are 1, 8, _____, _____, _____, and _____.

True/False. Determine whether each statement is true or false. If a statement is false, explain how it can be changed so the statement will be true. (**Note:** There may be more than one acceptable change.)

7. The expression $x^2 + 20x + 100$ is a perfect square trinomial.
8. When factoring polynomials, always look for a common monomial factor first.
9. The sum of two squares, $(x^2 + a^2)$, is factorable.
10. Sixty-four is a perfect square and a perfect cube.

Practice

Completely factor each of the given polynomials. If a polynomial cannot be factored, write "not factorable." See Examples 1 through 4.

- | | | |
|-----------------------|------------------------------|-----------------------|
| 1. $x^2 - 25$ | 22. $9y^2 + 12y + 4$ | 43. $4x^3 - 32$ |
| 2. $y^2 - 121$ | 23. $16x^2 - 40x + 25$ | 44. $64x^3 + 27y^3$ |
| 3. $81 - y^2$ | 24. $9x^2 - 12x + 4$ | 45. $54x^3 - 2y^3$ |
| 4. $25 - z^2$ | 25. $4x^3 - 64x$ | 46. $3x^4 + 375xy^3$ |
| 5. $2x^2 - 128$ | 26. $50x^3 - 8x$ | 47. $x^3y + y^4$ |
| 6. $3x^2 - 147$ | 27. $2x^3y + 32x^2y + 128xy$ | 48. $x^4y^3 - x$ |
| 7. $4x^4 - 64$ | 28. $3x^2y - 30xy + 75y$ | 49. $x^2y^2 - x^2y^5$ |
| 8. $5x^4 - 125$ | 29. $y^2 + 6y + 9$ | 50. $2x^2 - 16x^2y^3$ |
| 9. $y^2 + 100$ | 30. $y^2 + 4y + 4$ | 51. $24x^4y + 81xy^4$ |
| 10. $4x^2 + 49$ | 31. $x^2 - 20x + 100$ | 52. $x^6 - 64y^3$ |
| 11. $y^2 - 16y + 64$ | 32. $25x^2 - 10x + 1$ | 53. $x^6 - y^9$ |
| 12. $z^2 + 18z + 81$ | 33. $x^4 + 10x^2y + 25y^2$ | 54. $64x^2 + 1$ |
| 13. $-4x^2 + 100$ | 34. $16x^4 + 8x^2y + y^2$ | 55. $27x^3 + y^6$ |
| 14. $-12x^4 + 3$ | 35. $x^3 - 125$ | 56. $x^3 + 64z^3$ |
| 15. $9x^2 - 25$ | 36. $x^3 - 64$ | 57. $8x^3 + y^3$ |
| 16. $4x^2 - 49$ | 37. $y^3 + 216$ | 58. $x^3 + 125y^3$ |
| 17. $y^2 - 10y + 25$ | 38. $y^3 + 1$ | 59. $8y^3 - 8$ |
| 18. $x^2 + 12x + 36$ | 39. $x^3 + 27y^3$ | 60. $36x^3 + 36$ |
| 19. $4x^2 - 4x + 1$ | 40. $8x^3 + 1$ | 61. $9x^2 - y^2$ |
| 20. $49x^2 - 14x + 1$ | 41. $x^2 + 64y^2$ | 62. $x^2 - 4y^2$ |
| 21. $25x^2 + 30x + 9$ | 42. $3x^3 + 81$ | 63. $x^4 - 16y^4$ |

64. $81x^4 - 1$

65. $(x - y)^2 - 81$

66. $(x + 2y)^2 - 25$

67. $(x^2 - 2xy + y^2) - 36$

68. $(x^2 + 4xy + 4y^2) - 25$

69. $(16x^2 + 8x + 1) - y^2$

70. $x^2 - (y^2 + 6y + 9)$

Solve.

71. a. Represent the area of the shaded region of the square shown below as the difference of two squares.

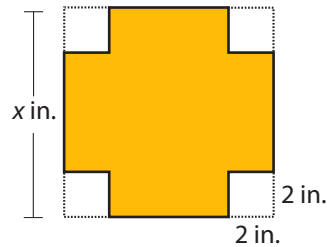

- b. Use the factors of the expression in part a. to draw (and label the sides of) a rectangle that has the same area as the shaded region.

72. a. Use a polynomial function to represent the area of the shaded region of the square.

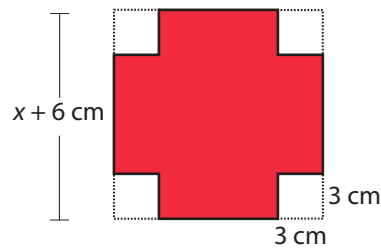

- b. Use a polynomial function to represent the perimeter of the shaded figure.

Writing & Thinking

73. a. Show that the sum of the areas of the rectangles and squares in the figure is a perfect square trinomial.
- b. Rearrange the rectangles and squares in the form of a square and represent its area as the square of a binomial.

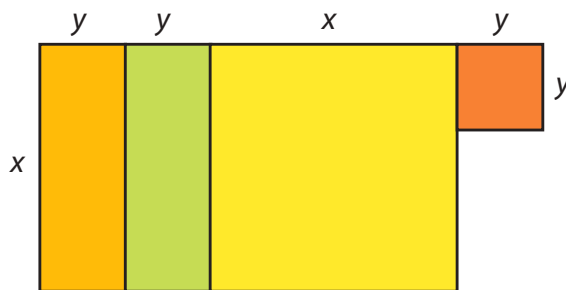

74. Compound interest is interest earned on interest. If a principal P is invested and compounded annually (once a year) at a rate of r , then the amount, A_1 accumulated in one year is $A_1 = P + Pr$.

In factored form, we have $A_1 = P + Pr = P(1 + r)$.

At the end of the second year the amount accumulated is $A_2 = (P + Pr) + (P + Pr)r$.

- a. Write the expression for A_2 in factored form similar to that for A_1 .
- b. Write an expression for the amount accumulated in three years, A_3 , in factored form.
- c. Write an expression for A_n the amount accumulated in n years.
- d. Use the formula you developed in part c. and your calculator to find the amount accumulated if \$10,000 is invested at 6% and compounded annually for 20 years.

75. You may have heard of (or studied) the following rules for division of an integer by 3 and 9:

1. An integer is divisible by 3 if the sum of its digits is divisible by 3.
2. An integer is divisible by 9 if the sum of its digits is divisible by 9.

The proofs of both **1.** and **2.** can be started as follows.

Let abc represent a three-digit integer.

$$\begin{aligned} \text{Then } abc &= 100a + 10b + c \\ &= (99 + 1)a + (9 + 1)b + c \\ &= (\text{now you finish the proofs}) \end{aligned}$$

Use the pattern just shown and prove both **1.** and **2.** for a four-digit integer.

8.6 Exercises

Concept Check

Fill-in-the-Blank. Complete each sentence using information found in this section.

- If a trinomial is not a perfect square trinomial, you can try factoring it by using the _____ method or the ____-method.
- When factoring a polynomial with two terms, check to see if it is of the form of the sum or difference of two _____ or two _____.
- Factoring can be checked by multiplying the factors. The product should be the _____ expression.
- If there are four terms when factoring, consider factoring by _____.
- When factoring, always look for a common _____ factor first.

True/False. Determine whether each statement is true or false. If a statement is false, explain how it can be changed so the statement will be true. (**Note:** There may be more than one acceptable change.)

- You should always start by checking the number of terms when factoring a polynomial.
- If a trinomial is to be factored, the trial-and-error or *ac*-methods can be used.
- If there are four terms in a polynomial, it cannot be factored.

Practice

Completely factor each of the given polynomials. If a polynomial cannot be factored, write "not factorable."

- | | | |
|-----------------------|-------------------------|---------------------------|
| 1. $m^2 + 7m + 6$ | 12. $49x^2 + 4$ | 23. $x^3 - 4x^2 - 12x$ |
| 2. $a^2 - 4a + 3$ | 13. $x^2 + 10x + 25$ | 24. $3n^3 + 15n^2 + 18n$ |
| 3. $x^2 + 11x + 18$ | 14. $x^2 + 3x - 10$ | 25. $112a - 2a^2 - 2a^3$ |
| 4. $y^2 + 8y + 15$ | 15. $x^2 + 9x - 36$ | 26. $200x + 20x^2 - 4x^3$ |
| 5. $x^2 - 100$ | 16. $x^2 + 16x + 64$ | 27. $16x^3 - 100x$ |
| 6. $n^2 - 8n + 12$ | 17. $3a^2 + 12a - 36$ | 28. $48x^3 - 27x$ |
| 7. $m^2 - m - 6$ | 18. $-2y^2 + 24y - 70$ | 29. $-3x^2 + 17x - 10$ |
| 8. $y^2 - 49$ | 19. $-5x^2 + 70x - 240$ | 30. $2x^2 + 7x + 3$ |
| 9. $a^2 + 2a + 24$ | 20. $7t^2 + 14t - 168$ | 31. $6x^2 - 11x + 4$ |
| 10. $-x^2 - 12x - 35$ | 21. $64 + 49t^2$ | 32. $12x^2 - 32x + 5$ |
| 11. $64a^2 - 1$ | 22. $3x^2 - 147$ | 33. $12m^2 + m - 6$ |

34. $6t^2 + t - 35$ 50. $252x - 175x^3$ 66. $2x^3 - 14x^2 - 3x + 21$
35. $4x^2 - 14x + 6$ 51. $12n^2 - 60n - 75$ 67. $x^3 + 125$
36. $-4x^2 + 18x - 20$ 52. $-12x^3 - 2x^2 - 70x$ 68. $y^3 - 1000$
37. $8x^2 + 6x - 35$ 53. $21a^3 - 13a^2 - 2a$ 69. $x^4y^3 - x^4$
38. $12x^2 + 5x - 3$ 54. $13x^3 + 120x^2 + 100x$ 70. $x^6y^3 - x^3$
39. $20x^2 - 21x - 54$ 55. $36x^3 + 21x^2 - 30x$ 71. $8a^6 + 27b^6$
40. $21x^2 - x - 10$ 56. $63x - 3x^2 - 30x^3$ 72. $a^9 + 64b^3$
41. $14 + 11x - 15x^2$ 57. $16x^3 - 52x^2 + 22x$ 73. $x^6y^3 - 125$
42. $24 + x - 3x^2$ 58. $24y^3 - 4y^2 - 160y$ 74. $x^3y^3 + 216$
43. $-8a^2 + 22a - 15$ 59. $75 + 10m + 120m^2$ 75. $x^3 + 7x^2 - 9x - 63$
44. $63x^2 - 40x - 12$ 60. $144x^3 - 10x^2 - 50x$ 76. $x^5 + 5x^4 - 4x - 20$
45. $20y^2 + 9y - 20$ 61. $xy + 3y - 4x - 12$ 77. $9x^2 - (y + 6)^2$
46. $35x^2 - x - 6$ 62. $2xz + 10x + z + 5$ 78. $(x + 2)^2 - 25a^2$
47. $18x^2 - 15x + 2$ 63. $x^2 + 2xy - 6x - 12y$ 79. $(y^2 + 20y + 100) - 49x^2$
48. $12x^2 - 47x + 11$ 64. $2y^2 + 6yz + 5y + 15z$ 80. $(t^2 + 22t + 121) - 16s^2$
49. $-150x^2 + 96$ 65. $-x^3 + 8x^2 + 5x - 40$

8.7 Exercises

Concept Check

Fill-in-the-Blank. Complete each sentence using information found in this section.

1. When solving quadratic equations by factoring, it is necessary to have one side of the equation equal to _____.
2. The zero-factor law states that if the product of two or more factors equals zero, then at least one of the factors must be _____.
3. The factor theorem states that if $x = c$ is a root of a polynomial equation in the form $P(x) = 0$, then $x - c$ is a/an _____ of the polynomial $P(x)$.
4. In general, a quadratic equation has two solutions. If the two solutions are the same number, the equation is said to have a/an _____ solution or root.
5. Solutions can be checked by _____ them one at a time for x in the equation.
6. Second-degree polynomials are called _____ polynomials.

True/False. Determine whether each statement is true or false. If a statement is false, explain how it can be changed so the statement will be true. (**Note:** There may be more than one acceptable change.)

7. When solving quadratic equations by factoring, it is important that all of the coefficients are integers.
8. The standard form for a quadratic equation is $ax^2 + bx = c$.
9. Not all quadratic equations can be solved by factoring.
10. All quadratic equations have two distinct solutions.

Practice

Solve each equation. See Example 1.

- | | |
|-----------------------|---------------------|
| 1. $(x-3)(x-2) = 0$ | 7. $(x+5)(x+5) = 0$ |
| 2. $(x+5)(x-2) = 0$ | 8. $(x+5)(x-5) = 0$ |
| 3. $(2x-9)(x+2) = 0$ | 9. $2x(x-2) = 0$ |
| 4. $(x+7)(3x-4) = 0$ | 10. $3x(x+3) = 0$ |
| 5. $0 = (x+3)(x+3)$ | 11. $(x+6)^2 = 0$ |
| 6. $0 = (x+10)(x-10)$ | 12. $5(x-9)^2 = 0$ |

Solve each equation by factoring. See Examples 2 through 9.

- | | |
|------------------------|-------------------------|
| 13. $x^2 - 3x - 4 = 0$ | 14. $x^2 + 7x + 12 = 0$ |
|------------------------|-------------------------|

15. $x^2 - x - 12 = 0$
16. $x^2 - 11x + 18 = 0$
17. $0 = x^2 + 3x$
18. $0 = x^2 - 3x$
19. $x^2 + 8 = 6x$
20. $x^2 = x + 30$
21. $2x^2 + 2x - 24 = 0$
22. $9x^2 + 63x + 90 = 0$
23. $0 = 2x^2 - 5x - 3$
24. $0 = 2x^2 - x - 3$
25. $3x^2 - 4x - 4 = 0$
26. $3x^2 - 8x + 5 = 0$
27. $2x^2 - 7x = 4$
28. $4x^2 + 8x = -3$
29. $-2x = 3x^2 - 8$
30. $6x^2 + 2 = -7x$
31. $4x^2 - 12x + 9 = 0$
32. $25x^2 - 60x + 36 = 0$
33. $8x = 5x^2$
34. $15x = 3x^2$
35. $9x^2 - 36 = 0$
36. $4x^2 - 16 = 0$
37. $5x^2 = 10x - 5$
38. $2x^2 = 4x + 6$
39. $8x^2 + 32 = 32x$
40. $6x^2 = 18x + 24$
41. $\frac{x^2}{9} = 1$
42. $\frac{x^2}{2} = 8$
43. $\frac{x^2}{5} - x - 10 = 0$
44. $\frac{2}{3}x^2 + 2x - \frac{20}{3} = 0$
45. $\frac{x^2}{8} + x + \frac{3}{2} = 0$
46. $\frac{x^2}{6} - \frac{1}{2}x - 3 = 0$
47. $x^2 - x + \frac{1}{4} = 0$
48. $\frac{x^2}{3} - 2x + 3 = 0$
49. $x^3 + 8x = 6x^2$
50. $x^3 = x^2 + 30x$
51. $6x^3 + 7x^2 = -2x$
52. $3x^3 = 8x - 2x^2$
53. $0 = x^2 - 100$
54. $0 = x^2 - 121$
55. $3x^2 - 75 = 0$
56. $5x^2 - 45 = 0$
57. $x^2 + 8x + 16 = 0$
58. $x^2 + 14x + 49 = 0$
59. $3x^2 = 18x - 27$
60. $5x^2 = 10x - 5$
61. $(x - 1)^2 = 4$
62. $(x - 3)^2 = 1$
63. $(x + 5)^2 = 9$
64. $(x + 4)^2 = 16$
65. $(x + 4)(x - 1) = 6$
66. $(x - 5)(x + 3) = 9$
67. $27 = (x + 2)(x - 4)$
68. $-1 = (x + 2)(x + 4)$
69. $x(x + 7) = 3(x + 4)$

70. $x(x+9) = 6(x+3)$

73. $x(2x+1) = 6(x+2)$

71. $3x(x+1) = 2(x+1)$

74. $3x(x+3) = 2(2x-1)$

72. $2x(x-1) = 3(x-1)$

Find a polynomial equation with integer coefficients that has the given roots. See Example 10.

75. $y = 3, y = -2$

80. $y = \frac{2}{3}, y = \frac{1}{6}$

76. $x = 5, x = 7$

81. $x = 0, x = 3, x = -2$

77. $x = -5, x = -\frac{1}{2}$

82. $y = 0, y = -4, y = 1$

78. $x = \frac{1}{4}, x = -1$

83. $y = -2, y = 3, y = 3$ (3 is a double root.)

79. $x = \frac{1}{2}, x = \frac{3}{4}$

84. $x = -1, x = -1, x = -1$ (-1 is a triple root.)

Applications

Solve.

85. A ball is dropped from the top of a building that is 784 feet high. The height of the ball above ground level is given by the polynomial function $h(t) = -16t^2 + 784$, where t is measured in seconds.

- How high is the ball after 3 seconds?
5 seconds?
- How far has the ball traveled in 3 seconds?
5 seconds?
- When will the ball hit the ground? Explain your reasoning in terms of factors.

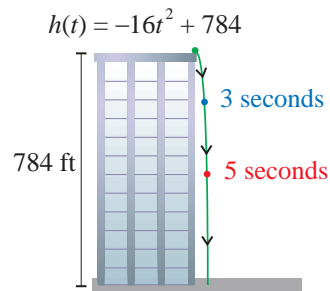

86. A tennis ball is dropped from a building. The position of the ball after t seconds is given by the polynomial function $s(t) = -4.9t^2 + 490$, where s is the height in meters of the ball.
- Find $s(0)$. What does this value represent in the context of this problem?
 - How high is the tennis ball 2 seconds after it has been dropped?
 - How long before the tennis ball hits the ground?
87. A ball is thrown upward from an initial height of 96 feet with an initial velocity of 16 feet per second. After t seconds, the height of the ball can be described by the equation $h = -16t^2 + 16t + 96$.
- What happens when $h = 0$?
 - Rewrite the equation with $h = 0$.
 - Solve the equation by factoring.
 - What does the answer to part c. mean?
 - Do both solutions from part c. make sense in the context of the problem? Explain why or why not.

88. Robin is putting the finishing touches on a quilt. The quilt is currently 80 inches long by 60 inches wide, and she plans to add a border around the quilt. The width of the border on the sides will be twice the width of the border on the top and bottom of the quilt.
- If x is the width of the border in inches that will be added to the top and bottom of the quilt, write an expression for the length and width of the quilt with the border added.
 - Write a simplified expression to find the area of the quilt with the border added.
 - Robin has a total of 5712 square inches of fabric to use for the back of the quilt. Use the expression from part b. to write an equation to describe the total area of the back of the quilt.
 - Solve the quadratic equation from part c. by factoring.
 - Do both of the solutions from part d. make sense in the context of the problem?
 - What is the total length and width of the quilt?
89. We know that the area of a circle is proportional to the square of the radius. In fact, if the radius of a circle is r , then the area of the circle is $A = \pi r^2$. Let's determine how the area is changed when we double the radius.
- Find the area of the circle for a radius of 1 in.
 - Find the area of the circle for a radius of 2 in.
 - Find the area of the circle for a radius of 4 in.
 - Find the area of the circle for a radius of 8 in.
 - Do you see the pattern? If you double the radius, by how many times does the area increase?
90. The St. Louis Arch is not quite in the shape of a parabola, but it can be closely modeled with the polynomial function $h(x) = -0.007x^2 + 0.003x + 625$, where x and $h(x)$ are both measured in feet and the center of the arch lies along the y -axis.
- Find $h(0)$. What does this mean in this context?
 - Find $h(100)$. What does this mean in this context?
 - Find $h(300)$. Use this value to approximate the total distance between the two points at which the arch hits the ground.
 - Use your graphing calculator to sketch the graph and find the x -intercepts (to the nearest integer). What is the actual distance between the two points at which the arch hits the ground? (rounded to the nearest foot) (**Note:** See Section 5.5 to review finding x -intercepts by using a graphing calculator.)

Writing & Thinking

91. When solving equations by factoring, one side of the equation must be 0. Explain why this is so.
92. In solving the equation $(x+5)(x-4) = 6$, why can't we just put one factor equal to 3 and the other equal to 2? Certainly $3 \cdot 2 = 6$.

8.8 Exercises

Concept Check

Fill-in-the-Blank. Complete each sentence using information found in this section.

1. Once an application problem has been read and understood, you should assign a _____ to the _____ quantities.
2. After an application problem has been solved, it is important to _____ the solution with the problem to make sure the answer makes sense.
3. Even integers are _____ if each is 2 more than the previous even integer.
4. The formula (or equation) related to the Pythagorean Theorem is _____.
5. Integers are consecutive if each is ___ more than the previous integer.
6. Two consecutive odd integers can be represented by n and _____.

True/False. Determine whether each statement is true or false. If a statement is false, explain how it can be changed so the statement will be true. (**Note:** There may be more than one acceptable change.)

7. The Pythagorean Theorem states that if the two legs of a right triangle are added, the sum will equal the hypotenuse.
8. The expressions n , $n + 1$, and $n + 2$ can represent three consecutive integers.
9. The Pythagorean Theorem can be used with any triangle.
10. The three numbers -10 , -8 , and -6 are consecutive even integers.

Applications

Write a quadratic equation for each of the following word problems. Then solve the word problem. Remember to check each solution with the wording of the original problem to make sure it is reasonable. See Examples 1 through 7.

1. One number is eight more than another. Their product is -16 . What are the numbers?
2. One number is 10 more than another. If their product is -25 , find the numbers.
3. The square of an integer is equal to seven times the integer. Find the integer.
4. The square of an integer is equal to twice the integer. Find the integer.
5. If the square of a positive integer is added to three times the integer, the result is 28. Find the integer.
6. If the square of a positive integer is added to three times the integer, the result is 54. Find the integer.
7. One number is three more than another. Their product is 40. Find the numbers.
8. One positive number is three more than twice another. If the product is 27, find the numbers.

9. One positive number is five more than another. The sum of their squares is 53. What are the numbers?
10. One number is five less than another. The sum of their squares is 97. Find the numbers.
11. The difference between two positive integers is 4. If the smaller is added to the square of the larger, the sum is 38. Find the integers.
12. One positive number is 3 more than twice another. If the square of the smaller is added to the larger, the sum is 51. Find the numbers.
13. The product of a negative integer and 5 less than twice the integer equals the integer plus 56. Find the integer.
14. Find a positive integer such that the product of the integer with a number three less than the integer is equal to the integer increased by 32.
15. The product of two consecutive positive integers is 72. Find the integers.
16. Find two consecutive integers whose product is 110.
17. Find two consecutive positive integers such that the sum of their squares is 85.
18. Find two consecutive positive integers such that the sum of their squares is 145.
19. The product of two consecutive odd integers is 63. Find the integers.
20. The product of two consecutive even integers is 80. Find the integers.
21. Find two consecutive positive integers such that the square of the second integer added to four times the first is equal to 41.
22. Find two consecutive negative integers such that 6 times the first plus the square of the second equals -14 .
23. Find three consecutive positive integers such that twice the product of the two smaller integers is 88 more than the product of the two larger integers.
24. Find three consecutive odd integers such that the product of the first and third is 1 more than 4 times the second.
25. Four consecutive integers are such that, if the product of the first and third is multiplied by 6, the result is equal to the sum of the second and the square of the fourth. What are the integers?
26. Find four consecutive even integers such that the square of the sum of the first and second is equal to 60 less than twice the product of the third and fourth.
27. The length of a rectangle is twice the width. The area is 72 square inches. Find the length and width of the rectangle.
28. The length of a rectangle is three times the width. If the area is 147 square centimeters, find the length and width of the rectangle.
29. The length of a rectangle is four times the width. If the area is 64 square feet, find the length and width of the rectangle.

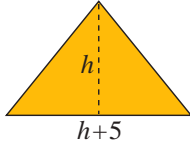
30. The length of a rectangle is five times the width. If the area is 180 square inches, find the length and width of the rectangle.
31. The width of a rectangle is 4 feet less than the length. The area is 45 square feet. Find the length and width of the rectangle.
32. The length of a rectangular yard is 3 meters greater than the width. If the area of the yard is 54 square meters, find the length and width of the yard.
33. The height of a triangle is 4 feet less than the base. The area of the triangle is 16 square feet. Find the length of the base and the height of the triangle.
34. The base of a triangle exceeds the height by 5 meters. If the area is 12 square meters, find the length of the base and the height of the triangle.
- 
35. The base of a triangle is 6 inches greater than the height. If the area is 20 square inches, find the length of the base.
36. The base of a triangle is 3 feet less than the height. The area is 9 square feet. Find the height.
37. The perimeter of a rectangle is 32 inches. The area of the rectangle is 48 square inches. Find the dimensions of the rectangle.
38. The area of a rectangle is 24 square centimeters. If the perimeter is 20 centimeters, find the length and width of the rectangle.
39. An orchard has 140 apple trees. The number of rows exceeds the number of trees per row by 13. How many trees are there in each row?
40. One formation for an army drill team is rectangular. The number of members in each row exceeds the number of rows by 3. If there is a total of 108 members in the formation, how many rows are there?
41. A theater can seat 144 people. The number of rows is 7 less than the number of seats in each row. How many rows of seats are there?
42. An empty field on a college campus is being used for overflow parking for a football game. It currently has 187 cars in it. If the number of rows of cars is six less than the number of cars in each row, how many rows are there?
43. The parking garage at Baltimore-Washington International Airport contains 8400 parking spaces. The number of cars that can be parked on each floor exceeds the number of floors by 1675. How many floors are there in the parking garage?
44. One bookshelf in the public library can hold 175 books. The number of books on each shelf exceeds the number of shelves by 18. How many books are on each shelf?
45. The length of a rectangle is 7 centimeters greater than the width. If 4 centimeters are added to both the length and width, the new area would be 98 square centimeters. Find the dimensions of the original rectangle.
46. The width of a rectangle is 5 meters less than the length. If 6 meters are added to both the length and width, the new area will be 300 square meters. Find the dimensions of the original rectangle.

47. Susan is going to fence in a rectangular flower garden in her back yard. She has 50 feet of fencing, and she plans to use the house as the fence on one side of the garden. If the area is 300 square feet, what are the dimensions of the flower garden?
48. A rancher is going to build a corral with 52 yards of fencing. He is planning to use the barn as one side of the corral. If the area is 320 square yards, what are the dimensions?
49. A telephone pole is to have a guy wire attached to its top and anchored to the ground at a point that is at a distance 34 feet less than the height of the pole from the base. If the wire is to be 2 feet longer than the height of the pole, what is the height of the pole?
50. Lucy is standing next to the the General Sherman tree in Sequoia National Park, home of some of the largest trees in the world. The distance from Lucy to the base of the tree is 71 meters less than the height of the tree. If the distance from Lucy to the top of the tree is 1 meter more than the height of the tree, how tall is the General Sherman?
51. A Christmas tree is supported by a wire that is 1 foot longer than the height of the tree. The wire is anchored at a point whose distance from the base of the tree is 49 feet shorter than the height of the tree. What is the height of the tree?
52. An architect wants to draw a rectangle with a diagonal of 13 inches. The length of the rectangle is to be 2 inches more than twice the width. What dimensions should she make the rectangle?
53. Incline mats, or triangle mats, are offered with different levels of incline to help gymnasts learn basic moves. As the name may suggest, two sides of the mat are right triangles. If the height of the mat is 28 inches shorter than the length of the mat and the hypotenuse is 8 inches longer than the length of the mat, what is the length of the mat?

54. Bill uses mirrors to augment the “laser experience” at a laser show. At one show, he places three mirrors, A , B , C , in a right triangular form. If the distance between A and B is 15 m more than the distance between A and C , and the distance between B and C is 15 m less than the distance between A and C , what is the distance between mirror A and mirror C ?

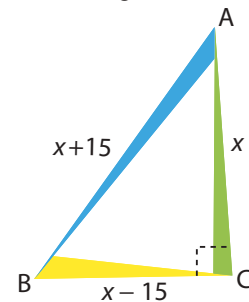

55. A support wire is attached x feet from the top of a 17-foot pole to protect the pole during a blizzard. The other end of each wire is attached to a stake x feet from the base of the pole. The wire used is 13 feet long.
- Draw a diagram to describe the situation. Be sure to label the figure with the known information.
 - Use the Pythagorean Theorem to write an equation that describes the situation. Do not simplify.
 - Simplify the equation from part b. and solve for x .
 - Do both solutions from part b. make sense in this situation? That is, do they both result in a positive distance on the pole and a positive distance from the pole?
 - What do the answers from part b. mean? (You should have two answers.)
 - Which answer from part d. seems like the better option? Write an explanation for your choice.

56. A family wants to fence in a rectangular area of their yard next to the house so their dog can play outside without being on a leash. One side of the fenced-in area will be along the side of the house, so they will only need to fence in three sides. The family decides to fence in an area of 4000 square feet and they purchase 180 feet of fencing. What are the dimensions of the fenced in area?
- Draw a diagram to represent the situation. Use the variable x to label the two sides of the fence which will have the same length.
 - Write an expression involving x to represent the length of the third side of the fence.
 - Write an equation to represent the area of the fenced-in yard.
 - Solve the equation from part c.
 - Do both solutions make sense in the context of the problem?
 - What are the possible dimensions of the fenced-in yard?

The **demand** for a product is the number of units of the product x that consumers are willing to buy when the market price is p dollars. The consumers' **total expenditure** for the product S is found by multiplying the price times the demand. ($S = px$) Solve the following consumer demand questions.

- During the summer at a local market, a farmer will sell $8p + 588$ pounds of peaches at p dollars per pound. If he sold \$900 worth of peaches this summer, what was the price per pound of the peaches?
- On a hot afternoon, fans at a stadium will buy $490 - 40p$ drinks for p dollars each. If the total sales after a game were \$1225, what was the price per drink?
- When fishing reels are priced at p dollars, local consumers will buy $36 - p$ fishing reels. What is the price if total sales were \$320?
- A manufacturer can sell $100 - 2p$ lamps at p dollars each. If the receipts from the lamps total \$1200, what is the price of the lamps?

Writing & Thinking

61. The pattern in Kara's linoleum flooring is in the shape of a square 8 inches on a side with right triangles (with legs whose lengths are x inches) placed on each side of the original square so that a new larger square is formed. What is the area of the new square? Explain why you do not need to find the value of x .

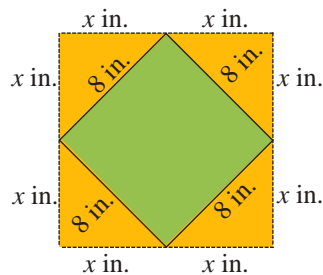

Common Error

“Divide out” only common factors.

Wrong Solution

$$\frac{4x+8}{8}$$

8 is not a common factor.

$$\frac{x^2-9}{x-3}$$

3 and x are not common factors.

Correct Solution

$$\frac{4x+8}{8} = \frac{4(x+2)}{8}$$

4 is a common factor.

$$\frac{x^2-9}{x-3} = \frac{(x+3)(x-3)}{(x-3)}$$

$x-3$ is a common factor.

CAUTION

Margin Exercise Answers

1. a. $x \neq \frac{1}{5}$ b. $x \neq 3, 4$ c. no restrictions 2. a. $-\frac{4}{11}$ b. $-\frac{1}{8}$
 3. a. $\frac{2}{5}; x \neq 3$ b. $\frac{x+4}{x+5}; x \neq -5, 5$ c. $-1; x \neq 5$

9.1 Exercises

Concept Check

Fill-in-the-Blank. Complete each sentence using information found in this section.

- The technical name for a fraction with integers in the numerator and denominator is _____ number.
- To simplify a rational expression, divide out any common _____ from the numerators and denominators.
- When a numerator and denominator are multiplied by the same number, this is an example of the _____ principle of rational expressions.
- Values that make an expression undefined cannot be used and are called _____ on the variable.
- The rules for rational expressions are the same as those for _____ in arithmetic.
- The denominator of a rational expression can never equal _____.

True/False. Determine whether each statement is true or false. If a statement is false, explain how it can be changed so the statement will be true. (**Note:** There may be more than one acceptable change.)

7. A simplified rational expression cannot have any common factors other than 1 and -1 in both the numerator and denominator.
8. The difference between a rational number and a rational expression is that a rational expression generally has polynomials in the numerator and/or denominator.
9. While a rational number cannot have a zero denominator, a rational expression can have a zero denominator.
10. If a denominator is $x + 5$, it is defined for all values except 5.

Practice

Reduce each expression to lowest terms. State any restrictions on the variable(s). See Examples 1 and 3.

- | | | |
|-----------------------------|--------------------------------|--------------------------------------|
| 1. $\frac{9x^2y^3}{12xy^4}$ | 8. $\frac{4-2x}{2x-4}$ | 15. $\frac{x^2-4x-21}{x^2-9}$ |
| 2. $\frac{18xy^4}{27x^2y}$ | 9. $\frac{9-3x}{4x-12}$ | 16. $\frac{x^2-11x+18}{x^2-4}$ |
| 3. $\frac{20x^5}{30x^2y^3}$ | 10. $\frac{2x-8}{16-4x}$ | 17. $\frac{xy-3y+2x-6}{y^2-4}$ |
| 4. $\frac{15y^4}{20x^3y^2}$ | 11. $\frac{6x^2+4x}{3xy+2y}$ | 18. $\frac{3x^2+14x-24}{18-9x-2x^2}$ |
| 5. $\frac{x}{x^2-3x}$ | 12. $\frac{1+3y}{4x+12xy}$ | 19. $\frac{x^2+5x-14}{5x-2y+xy-10}$ |
| 6. $\frac{3x}{x^2+5x}$ | 13. $\frac{x^2+6x}{x^2+5x-6}$ | 20. $\frac{x^2+10x+24}{2x^2+x-28}$ |
| 7. $\frac{7x-14}{x-2}$ | 14. $\frac{x^2-y^2}{3x^2+3xy}$ | |

Evaluate each rational expression for the given value of the variable. See Example 2.

- | | | |
|--------------------------------|-----------------------------------|---------------------------------|
| 21. $\frac{x-3}{3x^2}; x=5$ | 25. $\frac{2x^2+5x}{x^2-1}; x=0$ | 28. $\frac{-x+3}{x-3}; x=-10$ |
| 22. $\frac{2x+1}{3x-2}; x=1$ | 26. $\frac{n^3}{n^2-5n+6}; n=-1$ | 29. $\frac{15-x}{x-15}; x=1000$ |
| 23. $\frac{5x^2}{x^2-4}; x=-3$ | 27. $\frac{2m-7}{m^2+8m+12}; m=2$ | 30. $\frac{16+x}{x^2-16}; x=20$ |
| 24. $\frac{3y-4}{y^2+25}; y=3$ | | |

Applications

Solve.

-
- 31.** The cost of renting a party room with tables, chairs, and simple decorations is \$200 plus \$15 per person attending.
- Write a rational expression that represents the total price per person for renting the party room, where x is the number of people attending.
 - What is the price per person to rent the party room if 10 people are attending?
 - Determine which values of the variable will make the rational expression from part a. undefined.
 - Considering the context of the given problem, are there any additional restrictions on the variable? If so, explain why these restrictions are in place.
- 32.** Amelia wants to join the Fit4Life gym, a local gym that offers a variety of different fitness classes. At Fit4Life gym, it costs \$85 for a lifetime membership, and then you pay \$8 per class. They are currently running a special where you get the first 10 classes for free.
- Write a rational expression that represents the average price per class where x is the number of classes Amelia takes.
 - What is the price per class after taking 100 classes?
 - Determine which values of the variable will make the rational expression from part a. undefined.
 - Considering the context of the given problem, are there any additional restrictions on the variable? If so, explain why these restrictions are in place.
- 33.** Columbus High School plans to buy scientific calculators for use in their Earth Science classes. If they buy the calculators in bulk from Math Supplies Plus, the cost per calculator depends on how many calculators are purchased. The cost per calculator c is determined by the equation $c = \frac{4(x+60)}{x+20}$, where x is the number of calculators purchased.
- Find the cost per calculator if only 1 calculator is purchased.
 - Find the cost per calculator if 50 calculators are purchased.
 - Find the cost per calculator if 100 calculators are purchased.
 - What trend do you notice about the cost per calculator as the number of calculators purchased increases?
 - For what values of the variable is the price per calculator function undefined?
 - Considering the context of the equation, are there any additional restrictions on the variable? If so, explain why these restrictions are in place.

34. An annuity is a type of savings account that you put money into after equal periods of time to reach a goal amount. Annuities are a type of investment that is generally used to meet long-term savings goals such as college funds or retirement funds. The future value of an annuity is determined by the equation

$$FV = P \left[\frac{(1+r)^n - 1}{r} \right],$$

where FV is the future value of the annuity, P is the size of the periodic payment, r is the interest rate, and n is the number of payments or times the interest is compounded.

- Determine the future value of an annuity if the monthly payment is \$100, the interest rate is 3%, and the payments are made for 60 months. Round your answer to the nearest cent.
 - Determine the future value of an annuity if the monthly payment is \$200, the interest rate is 3%, and the payments are made for 60 months. Round your answer to the nearest cent.
 - What was the total amount of money paid into the annuity from part a.?
 - What was the total amount of money paid into the annuity from part b.?
 - The regular payment in part b. is double the regular payment in part a. Is the future value from part b. double the future value from part a.? Why do you think this is?
35. The area of a rectangle (in square feet) is represented by the polynomial function $A(x) = 4x^2 - 4x - 15$. If the length of the rectangle is $(2x + 3)$ feet, find a representation for the width.

$$A(x) = 4x^2 - 4x - 15$$

$$2x + 3$$

36. The area of a rectangle (in square feet) is represented by the polynomial function $A(x) = 3x^2 - x - 10$. If the length of the rectangle is $(3x + 5)$ feet, find a representation for the width.

$$A(x) = 3x^2 - x - 10$$

$$3x + 5$$

Writing & Thinking

- Define the term rational expression.
 - Give an example of a rational expression that is undefined for $x = -2$ and $x = 3$ and has a value of 0 for $x = 1$. Explain how you determined this expression.
 - Give an example of a rational expression that is undefined for $x = -5$ and never has a value of 0. Explain how you determined this expression.
- Write the opposite of each of the following expressions.
 - $3 - x$
 - $2x - 7$
 - $x + 5$
 - $-3x - 2$

4. $\frac{x^2 - x - 30}{3(x+3)}$; $x \neq -3, 2, 5$ 5. $\frac{x-1}{x}$; $x \neq 0, -3$ 6. $\frac{1}{4x^2y}$ 7. $-\frac{x}{y^2}$ 8. $\frac{x^2 - 8x + 15}{(3x+1)^2}$
9. $\frac{x+4}{x-4}$

9.2 Exercises

Concept Check

Fill-in-the-Blank. Complete each sentence using information found in this section.

- To multiply two or more rational expressions, first completely _____ each numerator and denominator.
- To divide any two rational expressions, multiply the first fraction by the _____ of the second fraction (the divisor).
- After a rational expression has been reduced, it is typical to multiply out the _____ and leave the _____ in factored form.
- Remember that no rational expression can have a denominator with a value of _____.
- When multiplying rational expressions, multiply the _____ and multiply the _____, keeping the expressions in factored form.

True/False. Determine whether each statement is true or false. If a statement is false, explain how it can be changed so the statement will be true. (**Note:** There may be more than one acceptable change.)

- The reciprocal of $\frac{x}{x+3}$ is $\frac{-x-3}{x}$.
- Dividing rational expressions is similar to dividing fractions.
- There are no restrictions on the denominator $12x^2$.
- Because $\frac{4x^2}{16x}$ reduces to $\frac{x}{4}$, there are no restrictions on the denominator.

Practice

Perform the indicated operations and reduce to lowest terms. Assume that no denominator has a value of 0.

- $\frac{3ax^2}{4b} \cdot \frac{6b^2}{27x^2y}$
- $\frac{18x^3}{5y^2} \cdot \frac{30y^3}{9x^4}$
- $\frac{24x^3}{25y^2} \cdot \frac{10y^5}{18x}$
- $\frac{16x^8}{3y^{11}} \cdot \frac{-21y^9}{10x^7}$
- $\frac{x^2-9}{x^2+2x} \cdot \frac{x+2}{x-3}$
- $\frac{16x^2-9}{3x^2-15x} \cdot \frac{6}{4x+3}$
- $\frac{x^2+2x-3}{x^2+3x} \cdot \frac{x}{x+1}$
- $\frac{4x+16}{x^2-16} \cdot \frac{x-4}{x}$

9. $\frac{x^2+6x-16}{x^2-64} \cdot \frac{1}{2-x}$
10. $\frac{4-x^2}{x^2-4x+4} \cdot \frac{3}{x+2}$
11. $\frac{x^2-5x+6}{x^2-4x} \cdot \frac{x-4}{x-3}$
12. $\frac{2x^2+x-3}{x^2+4x} \cdot \frac{2x+8}{x-1}$
13. $\frac{2x^2+10x}{3x^2+5x+2} \cdot \frac{6x+4}{x^2}$
14. $\frac{x+3}{x^2-16} \cdot \frac{x^2-3x-4}{x^2-1}$
15. $\frac{x}{x^2+7x+12} \cdot \frac{x^2-2x-24}{x^2-7x+6}$
16. $\frac{x^2-2x-3}{x+5} \cdot \frac{x^2-5x-14}{x^2-x-6}$
17. $\frac{8-2x-x^2}{x^2-2x} \cdot \frac{x-4}{x^2-3x-4}$
18. $\frac{3x^2+21x}{x^2-49} \cdot \frac{x^2-5x+4}{x^2+3x-4}$
19. $\frac{(x-2y)^2}{x^2-5xy+6y^2} \cdot \frac{x+2y}{x^2-4xy+4y^2}$
20. $\frac{4x^2+6x}{x^2+3x-10} \cdot \frac{x^2+4x-12}{x^2+5x-6}$
21. $\frac{2x^2+5x+2}{3x^2+8x+4} \cdot \frac{3x^2-x-2}{4x^3-x}$
22. $\frac{x^2+5x}{4x^2+12x+9} \cdot \frac{6x^2+7x-3}{x^2+10x+25}$
23. $\frac{x+2}{x^2-1} \cdot \frac{x^2-2x+1}{x^2+x-2}$
24. $\frac{x^2-9}{2x+16} \cdot \frac{x^2+6x-16}{x^2-5x+6}$
25. $\frac{x-2}{x+5} \cdot \frac{x^2+7x+10}{x^2-4x+4}$
26. $\frac{2x^2-7x+3}{x^2-9} \cdot \frac{3x^2+8x-3}{6x^2+x-1}$
27. $\frac{12x^2y}{9xy^9} \div \frac{4x^4y}{x^2y^3}$
28. $\frac{35xy^3}{24x^3y} \div \frac{15x^4y^3}{84xy^4}$
29. $\frac{45xy^4}{21x^2y^2} \div \frac{40x^4}{112xy^5}$
30. $\frac{x-3}{15x} \div \frac{4x-12}{5}$
31. $\frac{x-1}{6x+6} \div \frac{2x-2}{x^2+x}$
32. $\frac{7x-14}{x^2} \div \frac{x^2-4}{x^3}$
33. $\frac{6x^2-54}{x^4} \div \frac{x-3}{x^2}$
34. $\frac{x^2-25}{6x+30} \div \frac{x-5}{x}$
35. $\frac{2x-1}{x^2+2x} \div \frac{10x^2-5x}{6x^2+12x}$
36. $\frac{x+3}{x^2+3x-4} \div \frac{x+2}{x^2+x-2}$
37. $\frac{6x^2-7x-3}{x^2-1} \div \frac{2x-3}{x-1}$
38. $\frac{x^2-9}{2x^2+7x+3} \div \frac{x^2-3x}{2x^2+11x+5}$
39. $\frac{x^2-6x+9}{x^2-4x+3} \div \frac{2x^2-7x+3}{x^2-3x+2}$
40. $\frac{x^3+2x^2}{x^2+11x+28} \div \frac{4x^2}{x+7}$
41. $\frac{2x+1}{4x-x^2} \div \frac{4x^2-1}{x^2-16}$
42. $\frac{x^2-4x+4}{x^2+5x+6} \div \frac{x^2+2x-8}{x^2+7x+12}$
43. $\frac{x^2-x-6}{x^2+6x+8} \div \frac{x^2-4x+3}{x^2+5x+4}$
44. $\frac{x^2-x-12}{6x^2-25x-9} \div \frac{x^2-6x+8}{3x^2-17x-6}$

$$45. \frac{6x^2 + 5x + 1}{4x^3 - 3x^2} \div \frac{3x^2 - 2x - 1}{3x^2 - 2x + 1}$$

$$46. \frac{8x^2 + 2x - 15}{3x^2 + 13x + 4} \div \frac{2x^2 + 5x + 3}{6x^2 - x - 1}$$

$$47. \frac{3x^2 + 13x + 14}{4x^3 - 3x^2} \div \frac{6x^2 - x - 35}{4x^2 + 5x - 6}$$

$$48. \frac{3x^2 + 2x}{9x^2 - 4} \div \frac{9x^2 + 6x - 8}{9x^2 - 16}$$

$$49. \frac{x^2 - 8x + 15}{x^2 - 9x + 14} \div \frac{x^2 + 4x - 21}{x - 1}$$

$$50. \frac{6 - 11x - 10x^2}{2x^2 + x - 3} \div \frac{5x^3 - 2x^2}{3x^2 - 5x + 2}$$

$$51. \frac{x - 6}{x^2 - 7x + 6} \cdot \frac{x^2 - 3x}{x + 3} \cdot \frac{x^2 - 9}{x^2 - 4x + 3}$$

$$52. \frac{3x^2 + 11x + 10}{2x^2 + x - 6} \cdot \frac{x^2 + 2x - 3}{2x - 1} \cdot \frac{2x - 3}{3x^2 + 2x - 5}$$

$$53. \frac{x^3 + 3x^2}{x^2 + 7x + 12} \cdot \frac{2x^2 + 7x - 4}{2x^2 - x} \cdot \frac{x^2 + 4x - 5}{2x^2 - x - 1}$$

$$54. \frac{x^2 + 2x - 3}{x^2 + 10x + 21} \cdot \frac{x^2 + 6x + 5}{x^2 - 7x - 8} \cdot \frac{x^2 - x - 56}{x^2 - 3x - 40}$$

$$55. \frac{2x^2 - 5x + 2}{4xy - 2y + 6x - 3} \div \frac{xy - 2y + 3x - 6}{2y^2 + 9y + 9}$$

$$56. \frac{2xy - 12x + y - 6}{y^2 - 2y - 24} \div \frac{2x^2 + 11x + 5}{xy + 5y + 4x + 20}$$

Applications

Solve

57. Erik is building a cubby bookshelf; that is, a bookshelf divided into storage holes (cubbies) instead of shelves. He wants the height of the bookshelf to be $x^2 - 3x - 10$ and the width to be $x^2 + 5x + 6$. Each cubby hole in the bookshelf will have a height of $x + 3$ and a width of $x - 5$.
- Write a rational expression to determine how many cubbies high the bookshelf will be.
 - Write a rational expression to determine how many cubbies wide the bookshelf will be.
 - Multiply the rational expressions from parts a. and b. (and reduce to lowest terms) to obtain a rational expression that gives the total number of cubbies in the entire bookshelf.
58. The station manager at WSTB The AlterNation is planning a giveaway for the month. The monthly budget for the station is decided by the expression $60x^2 + 330x + 360$ and the budget is split evenly between $x + 3$ things, including the giveaway. During the giveaway, the prizes will be given to every $x + 3$ caller. The station usually receives $5x^2 + 65x + 180$ calls during giveaways.
- Write a rational expression to determine how much of the budget will go to the giveaway.
 - Write a rational expression to determine how many callers will win prizes during the giveaway.
 - Find the rational expression used to determine the average amount the radio station can spend per prize by dividing the expression from part a. by the expression from part b. and reducing to lowest terms.

Solution

The denominator on the right is already factored and we see that we need to multiply by

$1 = \frac{x(x-1)}{x(x-1)}$ to get the equivalent expression with the desired denominator.

$$\frac{2x}{x^2-9} = \frac{2x}{(x+3)(x-3)} \cdot \frac{x(x-1)}{x(x-1)} = \frac{2x^2(x-1)}{x(x+3)(x-3)(x-1)}$$

Now work margin exercise 7.**Margin Exercise Answers**

1. 200 2. $\frac{5}{6}$ 3. $\frac{21}{20}$ 4. $5(x^2-9)$ 5. $4y(2y+1)^2(2y-1)$ 6. $-6x$ 7. $9x^2(x+3)$

9.3 Exercises

Concept Check

Fill-in-the-Blank. Complete each sentence using information found in this section.

- The least common multiple (LCM) of two or more whole numbers is the _____ number that is a multiple of each of these numbers.
- If two or more fractions have the same denominator, add the numerators and _____ the denominator.
- When finding the LCM, the first step is to find the _____ of each number.
- To find a rational expression equivalent to a given rational expression $\frac{P}{Q}$, choose R so that $Q \cdot R$ is the desired _____.
- When adding fractions with different denominators, you need to change each fraction into a/an _____ fraction with the denominator equal to the LCD of the fractions.

True/False. Determine whether each statement is true or false. If a statement is false, explain how it can be changed so the statement will be true. (**Note:** There may be more than one acceptable change.)

- When adding fractions with different denominators, add the denominators.
- The fraction $\frac{R}{R}$ is equivalent to 1.
- The least common denominator (LCD) is the least common multiple of the denominators.
- When finding the LCM of a set of polynomials, you only find the factors of any numerical terms.

Practice

Find the least common multiple (LCM) of each set of numbers. See Example 1.

- | | |
|---------------|----------------------|
| 1. 15, 25, 30 | 5. 20, 30, 40, 50 |
| 2. 18, 21, 63 | 6. 44, 55, 121 |
| 3. 16, 24, 27 | 7. 5, 10, 15, 20, 30 |
| 4. 35, 45, 63 | 8. 24, 36, 48, 54 |

Find the indicated sums and reduce, if possible. See Examples 2 and 3.

- | | |
|---|---|
| 9. $\frac{5}{17} + \frac{6}{17}$ | 14. $\frac{7}{10} + \frac{1}{5} + \frac{3}{10}$ |
| 10. $\frac{3}{25} + \frac{7}{25}$ | 15. $\frac{1}{2} + \frac{1}{10} + \frac{1}{6}$ |
| 11. $\frac{5}{8} + \frac{7}{8}$ | 16. $\frac{2}{15} + \frac{7}{15} + \frac{2}{45} + \frac{1}{30}$ |
| 12. $\frac{5}{6} + \frac{5}{6} + \frac{1}{6}$ | 17. $\frac{11}{18} + \frac{13}{54} + \frac{5}{27}$ |
| 13. $\frac{1}{2} + \frac{7}{10}$ | 18. $\frac{3}{4} + \frac{9}{10} + \frac{7}{20} + \frac{1}{2}$ |

Find the least common multiple (LCM) of each set of polynomials. See Examples 4 and 5.

- | | |
|--|---|
| 19. $x^2 - 25$, $7x + 35$ | 29. $x^2 + x - 12$, $x^2 + 9x + 20$ |
| 20. $x^2 - 14x + 49$, $9x - 63$ | 30. $x^2 - 3x + 2$, $x^2 - 7x + 6$ |
| 21. $6y - 24$, $3y - 12$, $5y - 20$ | 31. $x^2 + 5x - 14$, $xy - 2y + 3x - 6$ |
| 22. $20y + 32$, $15y + 24$, $45y + 72$ | 32. $y^2 + 4y + 3$, $xy + 3x - 5y - 15$ |
| 23. $x^2 - 9$, $x^2 - 6x + 9$ | 33. $2x^2 - 72$, $x^2 + 9x + 18$ |
| 24. $2x^2 - 50$, $x^2 - 10x + 25$ | 34. $5x^2 + 5x - 30$, $3x^2 - 9x + 6$ |
| 25. $y - 3$, $3 - y$ | 35. $2xy - 10y + 12x - 60$, $3y^2 + 21y + 18$ |
| 26. $22 - x$, $x - 22$ | 36. $8x^2 - 8y^2$, $x^2 - xy + 3x - 3y$ |
| 27. $x^2 - 144$, $24 - 2x$ | 37. $x^2 - 4$, $x^3 - 2x^2 + 4x - 8$ |
| 28. $30 - 3y$, $y^2 - 20y + 100$ | 38. $x^2 - 25$, $x^3 - 5x^2 + x - 5$ |

Write a rational expression on the right equivalent to the given rational expression on the left. See Examples 6 and 7.

$$39. \frac{7}{2x+3} = \frac{?}{4(2x+3)}$$

$$40. \frac{2x}{x^2-4x} = \frac{?}{2x^2(x-4)}$$

$$41. \frac{11}{2x+6} = \frac{?}{6(x+3)(x-3)}$$

$$42. \frac{5}{7(x-10)} = \frac{?}{35(x-10)(x+10)}$$

$$43. \frac{3x}{4-x} = \frac{?}{x(x-4)}$$

$$44. \frac{4}{5x-x^2} = \frac{?}{x(x-5)(x+5)}$$

$$45. \frac{y-1}{y^2+5y} = \frac{?}{2y(y+3)(y+5)}$$

$$46. \frac{x+3}{2x^2-x-1} = \frac{?}{(2x+1)(x-1)(3x-2)}$$

$$47. \frac{x+1}{x^2+1} = \frac{?}{(x^2+1)(x+3)}$$

$$48. \frac{x+5}{x^2+6} = \frac{?}{(x^2+6)(x-5)}$$

$$\begin{aligned}
\frac{15}{x^2-16} + \frac{x}{x+4} - \frac{x+3}{x-4} &= \frac{15}{(x+4)(x-4)} + \frac{x}{x+4} \cdot \frac{(x-4)}{(x-4)} - \frac{x+3}{x-4} \cdot \frac{(x+4)}{(x+4)} \\
&= \frac{15+x(x-4)-(x+3)(x+4)}{(x+4)(x-4)} \\
&= \frac{15+x^2-4x-(x^2+7x+12)}{(x+4)(x-4)} \\
&= \frac{15+x^2-4x-x^2-7x-12}{(x+4)(x-4)} \\
&= \frac{3-11x}{(x+4)(x-4)}
\end{aligned}$$

Now work margin exercise 7.

Completion Example Answers

3. LCD = $(y-5)(y+6)$;

$$\frac{y(y+6)}{(y-5)(y+6)} + \frac{3(y-5)}{(y+6)(y-5)} = \frac{(y^2+6y)+(3y-15)}{(y+6)(y-5)} = \frac{y^2+9y-15}{(y+6)(y-5)}$$

6. $\frac{x}{(x-2)(x+1)} - \frac{1(x+1)}{(x-2)(x+1)} = \frac{x-(x+1)}{(x-2)(x+1)} = \frac{-1}{(x-2)(x+1)}$

Margin Exercise Answers

1. a. $\frac{1}{x-5}$; $x \neq -5, 5$ b. $\frac{3}{x+5}$; $x \neq -5, -3$ 2. a. $\frac{x^2+6x+6}{(x+3)(x+2)}$ b. $\frac{x^2+2x-25}{(x+5)^2(x-5)}$

3. $\frac{s^2+5s+12}{(s+3)(s+1)}$ 4. a. $\frac{x+2y}{3x-y}$ b. $\frac{x-5}{x+3}$ c. $\frac{x+5}{x-4}$ 5. a. $\frac{x+18}{x+6}$ b. $\frac{15x^2-13xy-4y^2}{3(x+y)^2(x-y)}$

c. $\frac{-x^2-2x+12}{(x+6)(x+3)}$ d. $\frac{11y+17}{(x-2)(y+1)(y+3)}$ 6. $\frac{-4x+1}{(x-1)^2}$ 7. $\frac{8y-1}{(5-y)(5+y)}$

9.4 Exercises

Concept Check

Fill-in-the-Blank. Complete each sentence using information found in this section.

- To add rational expressions with a common denominator, proceed just as with fractions: add the _____ and keep the common _____.
- When finding the LCM for a set of polynomials, the first step is to _____ each polynomial.
- Next, form the product of all factors that appear, using each factor the _____ number of times it appears in any one polynomial.
- To add rational expressions with different denominators, first find the _____.

5. Then, rewrite each fraction in a/an _____ form with the LCD as the denominator.
6. The final step when adding or subtracting rational expressions is to _____, if possible.

True/False. Determine whether each statement is true or false. If a statement is false, explain how it can be changed so the statement will be true. (**Note:** There may be more than one acceptable change.)

7. The LCM of a set of denominators is called the least common denominator.
8. With polynomials, it is most common to place negative signs in the denominator.
9. As with addition, when subtracting rational expressions with different denominators, the first step is to find the LCM of the denominators.
10. You should not use parentheses when subtracting rational expressions.

Practice

Perform the indicated operations and reduce, if possible. Assume that no denominator has a value of 0.

1. $\frac{3x}{x+4} + \frac{12}{x+4}$
2. $\frac{7x}{x+5} + \frac{35}{x+5}$
3. $\frac{x-1}{x+6} + \frac{x+13}{x+6}$
4. $\frac{3x-1}{2x-6} + \frac{x-11}{2x-6}$
5. $\frac{3x+1}{5x+2} + \frac{2x+1}{5x+2}$
6. $\frac{x^2+3}{x+1} + \frac{4x}{x+1}$
7. $\frac{x-5}{x^2-2x+1} + \frac{x+3}{x^2-2x+1}$
8. $\frac{2x^2+5}{x^2-4} + \frac{3x-1}{x^2-4}$
9. $\frac{13}{7-x} - \frac{1}{x-7}$
10. $\frac{6x}{x-6} + \frac{36}{6-x}$
11. $\frac{3x}{x-4} + \frac{16-x}{4-x}$
12. $\frac{20}{x-10} - \frac{3}{10-x}$
13. $\frac{x^2+2}{x^2+x-12} + \frac{x+1}{12-x-x^2}$
14. $\frac{10}{x^2-x-6} - \frac{5x}{6+x-x^2}$
15. $\frac{x^2+2}{x^2-4} - \frac{4x-2}{x^2-4}$
16. $\frac{2x+5}{2x^2-x-1} - \frac{4x+2}{2x^2-x-1}$
17. $\frac{x+3}{7x-2} + \frac{2x-1}{14x-4}$
18. $\frac{3x+1}{4x+10} + \frac{4-x}{2x+5}$
19. $\frac{5}{x-3} + \frac{x}{x^2-9}$
20. $\frac{x+1}{x^2-3x-10} + \frac{x}{x-5}$
21. $\frac{x}{x-1} - \frac{4}{x+2}$
22. $\frac{x-1}{3x-1} - \frac{8+4x}{x+2}$
23. $\frac{x+2}{x+3} - \frac{4}{3-x}$
24. $\frac{x-1}{4-x} + \frac{3x}{x+5}$
25. $\frac{x+2}{3x+9} + \frac{2x-1}{2x-6}$
26. $\frac{x}{4x-8} - \frac{3x+2}{3x+6}$

27. $\frac{3x}{6+x} - \frac{2x}{x^2-36}$
28. $\frac{4}{x+5} - \frac{2x+3}{x^2+4x-5}$
29. $\frac{4x+1}{7-x} + \frac{x-1}{x^2-8x+7}$
30. $\frac{3x-4}{x^2-x-20} - \frac{2}{5-x}$
31. $\frac{4x}{x^2+3x-28} + \frac{3}{x^2+6x-7}$
32. $\frac{3x}{x^2+2x+1} - \frac{x}{x^2+9x+8}$
33. $\frac{3x+4}{2x^2-23x+30} - \frac{x+5}{2x^2-19x+24}$
34. $\frac{x+1}{x^2-3x+2} + \frac{6}{x^2-6x+8}$
35. $\frac{4x-1}{x^2-5x+4} + \frac{2x+7}{x^2-11x+28}$
36. $\frac{7x+3}{5x^2+27x+36} + \frac{3x-2}{5x^2+22x+24}$
37. $\frac{x-6}{7x^2-3x-4} + \frac{7-x}{7x^2+18x+8}$
38. $\frac{x+10}{x^2+5x+4} - \frac{4}{x^2+6x+8}$
39. $\frac{x-3}{4x^2-5x-6} - \frac{4x+10}{2x^2+x-10}$
40. $\frac{2x+1}{8x^2-37x-15} + \frac{2-x}{8x^2+11x+3}$
41. $\frac{3x}{4-x} + \frac{7x}{x+4} - \frac{x-3}{x^2-16}$
42. $\frac{x}{x+3} + \frac{x+1}{3-x} + \frac{x^2+4}{x^2-9}$
43. $-\frac{1}{2} + \frac{x-5}{x-3} + \frac{x-1}{x^2-5x+6}$
44. $-4 + \frac{1-2x}{x+6} + \frac{x^2+1}{x^2+4x-12}$
45. $\frac{2}{x^2-4} - \frac{3}{x^2-3x+2} + \frac{x-1}{x^2+x-2}$
46. $\frac{5}{x^2+3x+2} + \frac{4}{x^2+6x+8} - \frac{6}{x^2+5x+4}$
47. $\frac{x}{x^2+4x-21} + \frac{1-x}{x^2+8x+7} + \frac{3x}{x^2-2x-3}$
48. $\frac{3x}{x^2+4x-5} - \frac{2}{3x^2+17x+10} - \frac{3}{3x^2-x-2}$
49. $\frac{3x+9}{x^2-5x+4} + \frac{49}{12+x-x^2} + \frac{3x+21}{x^2+2x-3}$
50. $\frac{5x+22}{x^2+8x+15} + \frac{4}{x^2+4x+3} + \frac{6}{x^2+6x+5}$
51. $\frac{x}{xy+x-2y-2} + \frac{x+2}{xy+x+y+1}$
52. $\frac{4x}{xy-3x+y-3} + \frac{x+2}{xy+2y-3x-6}$
53. $\frac{3y}{xy+2x+3y+6} + \frac{x}{x^2-2x-15}$
54. $\frac{2}{xy-4x-2y+8} + \frac{5y}{y^2-3y-4}$
55. $\frac{x+6}{2x-1} - \frac{3x^2+x-4}{2x^2-3x+1}$
56. $\frac{2x-5}{2x^2+2} + \frac{x^2-2x+5}{x^3+x^2+x+1}$
57. $\frac{x+1}{x^3-3x^2+x-3} + \frac{x^2-5x-8}{x^4-8x^2-9}$
58. $\frac{x+4}{x^3-5x^2+6x-30} - \frac{x-7}{x^3-2x^2+6x-12}$
59. $\frac{x-6}{3x^2+10x+3} - \frac{2x}{x^2+2x-3} + \frac{6x}{3x^2-2x-1}$
60. $\frac{x+1}{2x^2-x-1} + \frac{2x}{2x^2+5x+2} - \frac{2x}{x^2+x-2}$

Applications

Solve.

- 61.** A landscaper is hired to place large flowering bushes along the borders of a botanical garden. The property is in the shape of a rectangle that measures $7x^2 + 3$ feet long by $4x^2 + 5$ feet wide. The bushes are to be placed every $x + 2$ feet across the width of the property and every $x - 2$ feet along the length of the property.
- Write a rational expression to determine how many bushes will go along one length of the property.
 - Write a rational expression to determine how many bushes will go along one width of the property.
 - Use the rational expressions from parts a. and b. to create a rational expression to determine how many bushes will be needed to line the entire property.
- 62.** Two teams of set designers are jointly creating a set for a scene in a movie. In one hour, the first team can create $\frac{1}{x}$ of the set and the second team can create $\frac{1}{2x-3}$ of the set. If the two teams work together, how much of the set will be completed in one hour?
- 63.** Three janitors work the night shift at the local hospital. Working alone, it takes Marla three more hours than it takes Tom, and it takes Bob twice as long as it takes Marla. So in one hour, Tom can clean $\frac{1}{x}$ of the building, Marla can clean $\frac{1}{x+3}$ of the building, and Bob can clean $\frac{1}{2x+6}$ of the building. If all three janitors work together, how much of the building can they clean in one hour?
- 64.** Anna's average running speed is three times faster than her walking speed. Since $\text{time} = \frac{\text{distance}}{\text{rate}}$, the time it takes Anna to run 30 km is $\frac{30}{3x}$ and the time it takes Anna to walk 30 km is $\frac{30}{x}$. Find the difference between Anna's walking time and running time for the 30 km.
- 65.** A car and a truck are both traveling to the same destination. The car is traveling 15 mph more than twice the speed of the truck. (Use the formula $\text{time} = \frac{\text{distance}}{\text{rate}}$.)
- Write a rational expression to describe the time it will take the truck to travel 100 miles.
 - Write a rational expression to describe the time it will take the car to travel 100 miles.
 - Find a rational expression to describe the difference in travel time between the truck and the car for the 100 miles.

66. During Expedition 34 to the International Space Station, three crew members are tasked with unloading supplies from the SpaceX Dragon spacecraft. In one hour, Chris Hadfield can unload $\frac{1}{x}$ of the supplies, Thomas Marshburn can unload $\frac{1}{x+4}$ of the supplies, and Oleg Novitskiy can unload $\frac{1}{x-2}$ of the supplies. If they work together, what portion of the supplies will they unload in one hour?
- Find the sum of the fractions of the supplies each crew member can unload in one hour.
 - If $x = 10$, what fraction of the supplies will be unloaded after one hour?
 - When $x = 10$, will more than half of the supplies be unloaded in one hour? Explain your answer.
67. Barbara's Bombtastic Bakery was a cupcake shop when it first opened up. The bakery space that Barbara rented came with most of the equipment that was needed, such as a commercial oven and a display case. This meant that she only had to buy a mixer for \$5000, cupcake pans for \$250, and various utensils for \$500. Barbara estimated that the ingredients for each cupcake would cost \$0.35.
- What was the total amount that Barbara spent on equipment to bake the cupcakes?
 - The total cost to bake the cupcakes is equal to the sum of the total amount spent on equipment plus the total amount spent on ingredients. Create a function $C(x)$ to describe the total cost to bake the cupcakes and use the variable x to represent the number of cupcakes baked.
 - The average cost to bake each cupcake is calculated by dividing the total cost by the number of cupcakes baked. Create a formula $A(x)$ to describe the average cost to create each cupcake.
 - After Barbara's Bombtastic Bakery's first week of business, Barbara baked a total of 950 cupcakes. What was the average cost to bake each cupcake after the first week? Round your answer to the nearest cent.
 - After one month of business, Barbara baked a total of 3500 cupcakes. What was the average cost to bake each cupcake after the first month? Round your answer to the nearest cent.

Writing & Thinking

68. Discuss the steps in the process you go through when adding two rational expressions with different denominators. That is, discuss how you find the least common denominator when adding rational expressions and how you use this LCD to find equivalent rational expressions that you can add.

C Simplifying Complex Algebraic Expressions

A **complex algebraic expression** is an expression that involves rational expressions and more than one operation. In simplifying such expressions, the rules for order of operations apply. As with complex fractions, the objective is to simplify the expression so that it is written in the form of a single reduced rational expression.

6. Simplify the following expression.

$$\frac{6}{x+4} + \frac{x}{x+4} \div \frac{x}{x-4}$$

Math Tip

Pay close attention to the order of operations when simplifying complex algebraic expressions. It may be tempting to add the numerators of the first two terms in Example 6 since they share a common denominator. However, this would give us the wrong solution since division between the second and third terms needs to happen first.

Example 6 Simplifying Complex Algebraic Expressions

Simplify the following expression.

$$\frac{4-x}{x+3} + \frac{x}{x+3} \div \frac{x}{x-3}$$

Solution

The rules for order of operations indicate that the division is to be done first, followed by the addition.

$$\begin{aligned} \frac{4-x}{x+3} + \frac{x}{x+3} \div \frac{x}{x-3} &= \frac{4-x}{x+3} + \frac{\cancel{x}}{x+3} \cdot \frac{x-3}{\cancel{x}} \\ &= \frac{4-x}{x+3} + \frac{x-3}{x+3} \\ &= \frac{4-x+x-3}{x+3} \\ &= \frac{1}{x+3} \end{aligned}$$

Now work margin exercise 6.

Margin Exercise Answers

1. $\frac{1}{3y}$ 2. $\frac{-6}{(x+6)^2}$ 3. $-9xy$ 4. $\frac{-6}{(x+6)^2}$ 5. $-9xy$ 6. $\frac{x+2}{x+4}$

9.5 Exercises

Concept Check

Fill-in-the-Blank. Complete each sentence using information found in this section.

- The goal in simplifying complex fractions is to create a reduced _____ expression.
- There are two methods of simplifying complex fractions. One method begins by simplifying the _____ and the _____ into single rational expressions.
- A second method of simplifying complex fractions requires that the ____ of all denominators be found.
- In a complex fraction, the large fraction bar is a symbol of _____.

5. An expression that involves rational expressions and more than one operation is called a/an _____ expression.
6. A fraction in which the numerator and/or denominator are fractions or are the sums and/or differences of fractions is considered a/an _____ fraction.

True/False. Determine whether each statement is true or false. If a statement is false, explain how it can be changed so the statement will be true. (**Note:** There may be more than one acceptable change.)

7. When simplifying complex fractions, the answer should always be reduced to lowest terms.
8. Complex fractions are those fractions in which only the denominator consists of one or more fractions itself.
9. Sometimes finding the LCM of all denominators is an important first step for simplifying complex fractions.
10. The LCM of the denominators of $\frac{2}{x-6}$ and $\frac{x}{6}$ is 6.

Practice

Simplify the following complex fractions. See Examples 1 through 5.

$$1. \frac{\frac{2x}{3y^2}}{\frac{5x^2}{6y}}$$

$$7. \frac{\frac{2x-1}{x}}{\frac{2}{x}+3}$$

$$13. \frac{\frac{1}{x} + \frac{1}{3x}}{\frac{x+6}{x^2}}$$

$$19. \frac{\frac{2}{x} + \frac{3}{4y}}{\frac{3}{2x} - \frac{5}{3y}}$$

$$2. \frac{\frac{6x^2}{5y}}{\frac{x}{10y^2}}$$

$$8. \frac{2 - \frac{3}{x}}{\frac{x}{x^2-4}}$$

$$14. \frac{\frac{3}{x} - \frac{6}{x^2}}{\frac{x-2}{x^2}}$$

$$20. \frac{\frac{4}{3x} - \frac{5}{y}}{\frac{1}{3} + \frac{3}{y}}$$

$$3. \frac{\frac{12x^3}{7y^2}}{\frac{3x^5}{2y}}$$

$$9. \frac{\frac{3}{x} + \frac{1}{2x}}{1 + \frac{2}{x}}$$

$$15. \frac{\frac{7}{x} - \frac{14}{x^2}}{\frac{1}{x} - \frac{4}{x^3}}$$

$$21. \frac{1+x^{-1}}{1-x^{-2}}$$

$$22. \frac{x^{-3}+1}{1-x^{-1}}$$

$$4. \frac{\frac{9x^2}{7y^3}}{\frac{3xy}{14}}$$

$$10. \frac{\frac{3}{x} + \frac{5}{2x}}{\frac{1}{x} + 4}$$

$$16. \frac{\frac{x}{3} + \frac{1}{9x^2}}{\frac{1}{27x^2} + \frac{x}{9}}$$

$$23. \frac{1}{x^{-1} + y^{-1}}$$

$$5. \frac{\frac{x+3}{2x}}{\frac{2x-1}{4x^2}}$$

$$11. \frac{1 + \frac{1}{x}}{1 - \frac{1}{x^2}}$$

$$17. \frac{\frac{1}{3} + \frac{1}{x}}{\frac{1}{2} - \frac{1}{x}}$$

$$24. \frac{x-y}{x^{-2} - y^{-2}}$$

$$25. \frac{x^{-1} + y^{-1}}{x+y}$$

$$6. \frac{\frac{x-2}{6x}}{\frac{x+3}{3x^2}}$$

$$12. \frac{\frac{2}{y} + 1}{\frac{4}{y^2} - 1}$$

$$18. \frac{\frac{x}{6} - \frac{1}{3}}{\frac{y}{6} - \frac{2}{x}}$$

$$26. \frac{y^{-2} - x^{-2}}{x+y}$$

$$27. \frac{x^{-1} + y^{-1}}{x^{-1} - y^{-1}}$$

28.
$$\frac{x^{-1} + y^{-1}}{x^{-2} - y^{-2}}$$

29.
$$\frac{\frac{4}{x} - 1}{1 - \frac{1}{x-3}}$$

30.
$$\frac{x + \frac{3}{x-4}}{1 - \frac{1}{x}}$$

31.
$$\frac{1 - \frac{4}{x+3}}{1 - \frac{2}{x+1}}$$

32.
$$\frac{1 + \frac{4}{2x-3}}{1 + \frac{x}{x+1}}$$

33.
$$\frac{\frac{1}{x+h} - \frac{1}{x}}{h}$$

34.
$$\frac{\frac{1}{(x+h)^2} - \frac{1}{x^2}}{h}$$

35.
$$\frac{\left(2 + \frac{1}{x+h}\right) - \left(2 + \frac{1}{x}\right)}{h}$$

36.
$$\frac{\left(\frac{1}{(x+h)^2} - 3\right) - \left(\frac{1}{x^2} - 3\right)}{h}$$

37.
$$\frac{x^2 - 4y^2}{1 - \frac{2x+y}{x-y}}$$

38.
$$\frac{8x^2 - 2y^2}{\frac{4x-1}{x-y} - 2}$$

39.
$$\frac{\frac{x+1}{x-1} - \frac{x-1}{x+1}}{\frac{x+1}{x-1} + \frac{x-1}{x+1}}$$

40.
$$\frac{\frac{1}{x^2-1} - \frac{1}{x+1}}{\frac{1}{x-1} + \frac{1}{x^2-1}}$$

41.
$$\frac{\frac{x}{x-4} - \frac{1}{x-1}}{\frac{x}{x-1} + \frac{2}{x-3}}$$

42.
$$\frac{\frac{1}{x+1} - \frac{x}{x+2}}{\frac{x}{x+2} - \frac{2}{x-1}}$$

Simplify the following complex algebraic expressions. See Example 6.

43.
$$\frac{1}{x+1} - \frac{3}{2x} \cdot \frac{4x}{x+1}$$

44.
$$\frac{4}{x} - \frac{2}{x^2-2x} \cdot \frac{x-2}{5}$$

45.
$$\left(\frac{8}{x} - \frac{3}{4x}\right) \div \frac{4x+5}{x}$$

46.
$$\left(\frac{2}{x} + \frac{5}{x-3}\right) \div \frac{x}{2x-6}$$

47.
$$\frac{x}{x-1} - \frac{3}{x-1} \cdot \frac{x+2}{x}$$

48.
$$\frac{x+3}{x+2} + \frac{x}{x+2} \cdot \frac{x-3}{x^2}$$

49.
$$\frac{x-1}{x+4} + \frac{x-6}{x^2+3x-4} \div \frac{x-4}{x-1}$$

50.
$$\frac{x}{x+3} - \frac{3}{x+5} \div \frac{x-2}{x^2+3x-10}$$

Applications

Solve.

51.  To calculate the average rate of a two-part commute, where each part is the same distance, the following formula is used.

$$\frac{2d}{\frac{d}{r_1} + \frac{d}{r_2}}$$

In the formula, d is the commute distance traveled one way, r_1 is the rate, or speed, during the first part of the trip, and r_2 is the rate during the second part of the trip.

- Simplify the expression.
 - Calculate the average rate of the trip if you can travel 35 miles per hour during the first part of the trip and 60 miles per hour during the second part of the trip. Round your answer to the nearest tenth.
 - Use the answer from part b. and the formula $d = rt$ to calculate how long the commute took if the total distance of the trip was 80 miles. Round your answer to the nearest tenth.
52. The average percent yield (APY) of an annuity is the annual interest rate earned in a given year that accounts for the effects of compounding. The APY acts as the interest rate for a simple interest account and is larger than the stated interest rate on the compound interest account. The formula to calculate the APY on an annuity after 2 years is

$$\text{APY} = \left(1 + \frac{r}{2}\right)^2 - 1,$$

where r is the stated interest rate.

- Simplify the expression for APY and write as a single rational expression.
- Using the original formula, calculate the APY for an annuity whose interest rate is 6%. Do not round.
- Using the expression in part a., calculate the APY for an annuity whose interest rate is 6%. Do not round.
- Does the result from part c. match the result from part b.? Explain why or why not.
- How much larger is the APY than the interest rate?
- Why do you think the APY is larger than the interest rate? Write a complete sentence.

Writing & Thinking

53. Some complex fractions involve the sum (or difference) of complex fractions. Beginning with the outermost denominator, simplify each of the following expressions.

$$\begin{array}{lll} \text{a. } 1 + \frac{1}{1 + \frac{1}{1 + \frac{1}{1+1}}} & \text{b. } 2 - \frac{1}{2 - \frac{1}{2 - \frac{1}{2-1}}} & \text{c. } x + \frac{1}{x + \frac{1}{x + \frac{1}{x+1}}} \end{array}$$

$$\begin{aligned}
 x^2 - 4x - 60 &= 0 \\
 (x-10)(x+6) &= 0 \\
 x-10=0 \quad \text{or} \quad x+6=0 \\
 x=10 \qquad \qquad x &= -6
 \end{aligned}$$

Because the length of a side cannot be negative, the only acceptable solution is $x = 10$. Thus, $\overline{QR} = 10$. Substituting 10 for x gives $\overline{AB} = 10 - 4 = 6$.

Now work margin exercise 8.

Completion Example Answers

Restrictions: $x \neq -5, 1$

$$\begin{aligned}
 6. \quad (x+5)(x-1) \cdot \frac{x}{x-1} - (x+5)(x-1) \cdot \frac{3x+1}{(x+5)(x-1)} &= (x+5)(x-1) \cdot \frac{x+2}{x+5} \\
 (x+5) \cdot x - (3x+1) &= (x-1)(x+2) \\
 x^2 + 5x - 3x - 1 &= x^2 + x - 2 \\
 2x - 1 &= x - 2 \\
 x &= -1
 \end{aligned}$$

Margin Exercise Answers

1. a. $x = 11$ b. $x = 16$ 2. 225 miles 3. $x \neq -7, -2, 0$; $x = -4, 3$ 4. $x \neq 0, 2$; $x = \frac{2}{5}$
 5. $x \neq -5, 0, 5$; no solution 6. $y \neq -5, 2$; $y = \frac{1}{7}$ 7. $l = \frac{SA - 2wh}{2h + 2w}$ 8. $x = 9$

9.6 Exercises

Concept Check

Fill-in-the-Blank. Complete each sentence using information found in this section.

1. A comparison of two numbers by division is called a/an _____.
2. An equation stating that two ratios are equal is called a/an _____.
3. Solutions that are not actually solutions of the original equation are called _____ solutions.
4. One method of solving proportions is to clear the equation of _____ by first multiplying both sides of the equation by the LCD.
5. Rational expressions may contain _____ in either the numerator, the denominator, or both.
6. When solving an equation containing rational expressions, multiply both sides of the equation by the LCD and _____.

True/False. Determine whether each statement is true or false. If a statement is false, explain how it can be changed so the statement will be true. (**Note:** There may be more than one acceptable change.)

7. An equation that involves the sum of rational expressions is also a proportion.
8. Multiplying by an LCD can cause extraneous roots.
9. A proportion is properly written if the numerators agree in type and the denominators agree in type.
10. When checking the solutions in the original equation, any solution that gives a 0 denominator cannot be checked.

Practice

State any restrictions on x , and then solve the proportions. See Example 1.

- | | |
|--------------------------------------|--------------------------------------|
| 1. $\frac{4x}{7} = \frac{x+5}{3}$ | 6. $\frac{3}{x+5} = \frac{6}{x-2}$ |
| 2. $\frac{3x+1}{4} = \frac{2x+1}{3}$ | 7. $\frac{x+2}{5x} = \frac{x-6}{3x}$ |
| 3. $\frac{10}{x} = \frac{5}{x-2}$ | 8. $\frac{x-4}{3x} = \frac{x-2}{5x}$ |
| 4. $\frac{8}{x-3} = \frac{12}{2x-3}$ | 9. $\frac{5x+2}{x-6} = \frac{11}{4}$ |
| 5. $\frac{4}{x-4} = \frac{2}{x+3}$ | 10. $\frac{x+9}{3x+2} = \frac{5}{8}$ |

State any restrictions on x , and then solve the equations. See Examples 3 through 6.

- | | |
|--|---|
| 11. $\frac{5x}{4} - \frac{1}{2} = -\frac{3}{16}$ | 20. $\frac{3}{8x} - \frac{7}{10} = \frac{1}{5x}$ |
| 12. $\frac{x}{6} - \frac{1}{42} = \frac{1}{7}$ | 21. $\frac{3}{4x} - \frac{1}{2} = \frac{7}{8x} + \frac{1}{6}$ |
| 13. $\frac{3x-1}{6} - \frac{x+3}{4} = \frac{7}{12}$ | 22. $\frac{5}{3x} + \frac{1}{2} = \frac{7}{9x} - \frac{5}{6}$ |
| 14. $\frac{x-2}{3} - \frac{x-3}{5} = \frac{13}{15}$ | 23. $\frac{2}{4x+1} = \frac{4}{x^2+9x}$ |
| 15. $\frac{2+x}{4} - \frac{5x-2}{12} = \frac{8-2x}{5}$ | 24. $\frac{3}{4x-1} = \frac{4}{x^2+x}$ |
| 16. $\frac{4x+1}{5} = \frac{2x+3}{2} - \frac{x+2}{4}$ | 25. $\frac{9}{x^2-6x} = \frac{5}{2x-3}$ |
| 17. $\frac{2}{3x} = \frac{1}{4} - \frac{1}{6x}$ | 26. $\frac{-9}{x^2+5x} = \frac{8}{4-9x}$ |
| 18. $\frac{1}{x} - \frac{8}{21} = \frac{3}{7x}$ | 27. $\frac{x}{x-4} - \frac{4}{2x-1} = 1$ |
| 19. $\frac{3}{5x} - \frac{1}{5} = \frac{3}{4x}$ | 28. $\frac{x}{x+3} + \frac{1}{x+2} = 1$ |

29. $\frac{x+2}{x+1} + \frac{x+2}{x+4} = 2$

30. $\frac{3x-2}{x+4} + \frac{2x+5}{x-1} = 5$

31. $\frac{2}{4x-1} + \frac{1}{x+1} = \frac{3}{x+1}$

32. $\frac{x-2}{x+4} - \frac{3}{2x+1} = \frac{x-7}{x+4}$

33. $\frac{x-2}{x-3} + \frac{x-3}{x-2} = \frac{2x^2}{x^2-5x+6}$

34. $\frac{x}{x-4} - \frac{12x}{x^2+x-20} = \frac{x-1}{x+5}$

35. $\frac{3x+5}{3x+2} + \frac{8x+16}{3x^2-4x-4} = \frac{x+2}{x-2}$

36. $\frac{3x+5}{3x+2} - \frac{4-2x}{3x^2+8x+4} = \frac{x+4}{x+2}$

37. $\frac{3}{3x-1} + \frac{1}{x+1} = \frac{4}{2x-1}$

38. $\frac{2}{x+1} + \frac{4}{2x-3} = \frac{4}{x-5}$

Solve each of the formulas for the specified variable. Assume no denominator has a value of 0. See Example 7.

39. $S = \frac{a}{1-r}$; solve for r (formula for the sum of an infinite geometric sequence)

40. $z = \frac{x-\bar{x}}{s}$; solve for x (formula used in statistics)

41. $z = \frac{x-\bar{x}}{s}$; solve for s (formula used in statistics)

42. $a_n = a_1 + (n-1)d$; solve for d (formula for the n^{th} term in an arithmetic sequence)

43. $m = \frac{y-y_1}{x-x_1}$; solve for y (formula for the slope of a line)

44. $v_{\text{avg}} = \frac{d_2-d_1}{t_2-t_1}$; solve for d_2 (formula for mean velocity)

45. $\frac{1}{R_{\text{total}}} = \frac{1}{R_1} + \frac{1}{R_2}$; solve for R_{total} (formula used in electronics)

46. $\frac{1}{x} = \frac{1}{t_1} + \frac{1}{t_2}$; solve for x (formula used in mathematics)

47. $A = P + Pr$; solve for P (formula used for compound interest)

48. $y = \frac{ax+b}{cx+d}$; solve for x (formula used in mathematics)

The following exercises show pairs of similar triangles. Find the lengths of the sides labeled with variables. See Example 8.

49. $\triangle JKL \sim \triangle JTB$

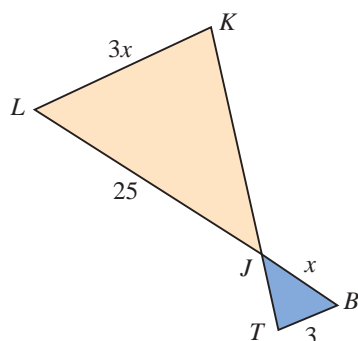

50. $\triangle QRP \sim \triangle TUS$

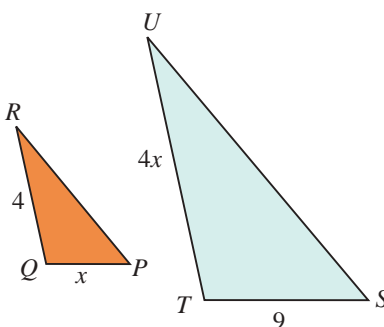

51. $\triangle ABC \sim \triangle RST$

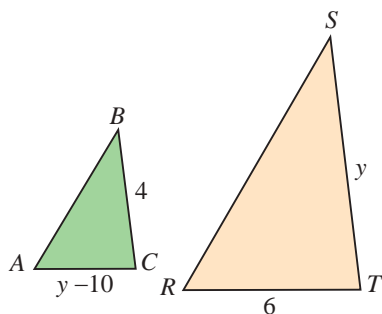

53. $\triangle SUT \sim \triangle PRQ$

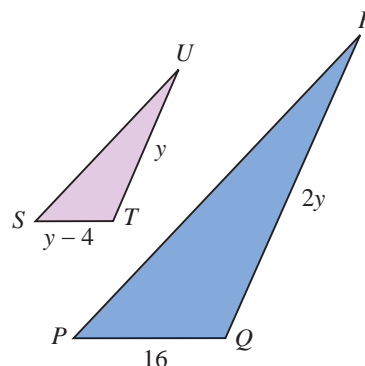

52. $\triangle FED \sim \triangle FGH$

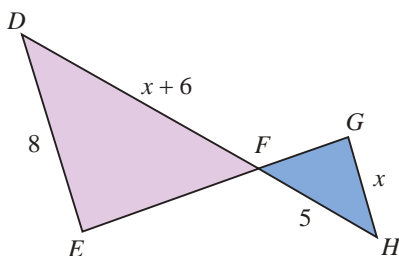

54. $\triangle ABC \sim \triangle DEC$

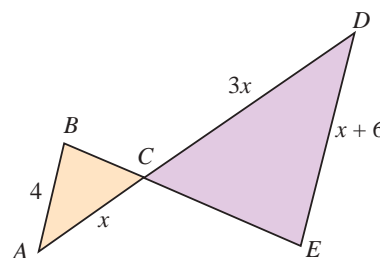

55. In the parallelogram $ABCD$, $AB = CD = 10$ in. Diagonal $AC = 12$ in. The point M on \overline{AB} is 6 in. from A . Point P is the intersection of \overline{DM} with \overline{AC} . The triangles APM and CPD are similar. (Symbolically, $\triangle APM \sim \triangle CPD$.) What are the lengths of \overline{AP} and \overline{PC} ?

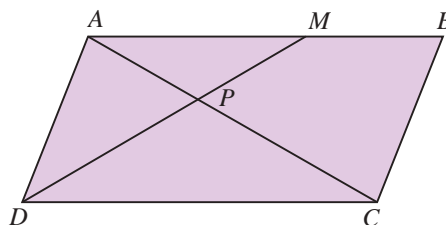

56. If, in the same parallelogram discussed in Exercise 55, the point P is the point of intersection of the two diagonals, \overline{AC} and \overline{DB} , what are the lengths of \overline{AP} and \overline{PC} ?

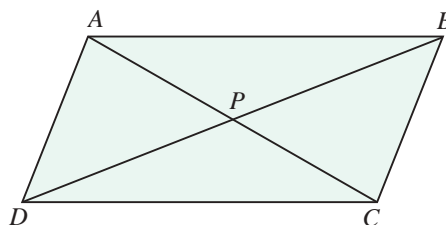

Applications

Solve.

57. Making a statistical analysis, Ana found 3 defective computers in a sample of 20 computers. If this ratio is consistent, how many defective computers does she expect to find in a batch of 2400 computers?
58. At the Bright-As-Day light bulb plant, 3 out of each 100 bulbs produced are defective. If the daily production is 4800 bulbs, how many are defective?
59. A university has a ratio of 1 professor for every 23 students. If there are 1600 faculty members at the university, how many students are enrolled there?
60. New York Yankees player Didi Gregorius has a recorded batting average of 15 hits for every 50 times at bat. If he maintains this average, how many at-bats will he need to achieve 111 hits? (Round to the nearest whole number.)
61. On a map of Maryland, one inch represents 4 miles. If there are 8.5 inches between Baltimore, MD, and Washington, DC, how far are the two cities from each other?
62. A floor plan is drawn to scale in which 1 inch represents 4 feet. What size will the drawing be for a room that is 30 feet by 40 feet? (**Hint:** Set up two proportions.)
63. The recipe for Nestle Tollhouse Chocolate Chip Cookies calls for 2 cups of chocolate chips to make 5 dozen cookies. If you want to bake 17 dozen cookies, how many cups of chocolate chips do you need?
64. The instructions for Never-Ice Antifreeze states that 4 quarts of antifreeze are needed for every 10 quarts of radiator capacity. If Sal's car has a 22-quart radiator, how many quarts of antifreeze will it need?
65. An architect is to draw plans for a city park. He intends to use a scale of $\frac{1}{2}$ inch to represent 25 feet. How many inches will be needed to use for the length and width of a rectangular playing field that is 50 yards by 125 yards? (**Note:** 1 yard = 3 feet.)
66. A test driver wants to increase the speed of the car he is driving by 3 miles per hour every 2 seconds. However, he can only check his speed every 5 seconds because he is busy with other tasks during the test drive.
 - a. By how much should he increase his speed in 5 seconds?
 - b. If he starts checking his speed at 40 miles per hour, how fast should he be going after 10 seconds?
67. Jack and Diane are decorating a nursery room for their baby, which will be born in a few months. In one hour, Jack can get $\frac{1}{6}$ of the nursery done and Diane can get $\frac{1}{12}$ of the nursery done. If they work together, they can get $\frac{1}{x}$ of the nursery done in one hour. Determine how many hours it will take Jack and Diane to decorate the nursery if they work together by solving the equation $\frac{1}{6} + \frac{1}{12} = \frac{1}{x}$ for x .

68. A local print shop has a big order of pamphlets to print, so they decide to use two of their printers for the one job. The newer printer can print the pamphlets four times as fast as the older printer. That means in one hour, the newer printer can complete $\frac{1}{x}$ of the print job and the older printer can complete $\frac{1}{4x}$ of the print job. Working together, the printers can complete the job in 4 hours. Determine how many hours it would take the newer printer to print all of the pamphlets by itself by solving the equation $\frac{1}{x} + \frac{1}{4x} = \frac{1}{4}$ for x .
69. Two groups of civil engineers are surveying an area to prepare for the construction of a shopping center. The first group is full of new college graduates, and it will take them four more hours than it takes the second group, which is full of seasoned professionals. The second group can complete the job in x hours. This means that in one hour, the first group can complete $\frac{1}{x+4}$ of the job and the second group can complete $\frac{1}{x}$ of the job. Working together, they can complete the surveying job in $\frac{15}{4}$ hours. Determine how many hours it would take each team to complete the job individually by solving the equation $\frac{1}{x+4} + \frac{1}{x} = \frac{4}{15}$ for x .
70. Terrence and Alicia are competing in a marathon where the average running speed is x kilometers per hour. Terrence is running 2 kilometers per hour slower than the average running speed. Alicia is running 2 kilometers per hour faster than the average running speed. After a certain amount of time, Terrence ran 4 kilometers and Alicia ran 6 kilometers.
- Determine the speed of the average runner by solving the equation $\frac{4}{x-2} = \frac{6}{x+2}$ for x .
 - What was Terrence's average running speed?
 - What was Alicia's average running speed?
 - How long did it take Terrence to run 4 kilometers and Alicia to run 6 kilometers?

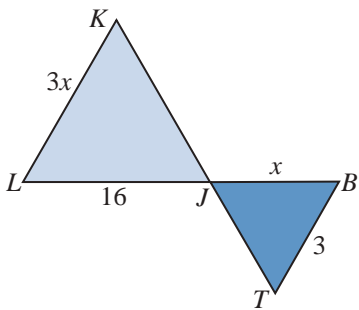

71. A team of gardeners is making two flower beds that are in the shape of similar triangles outside of an art museum. The apprentice gardener wasn't completely paying attention to the instructions given by the master gardener. All that he can remember is that the flower beds are isosceles triangles, the base of the small triangle is 3 feet wide, one side of the larger triangle is 16 feet long, and the base of the large triangle is three times the side length of the small triangle. The apprentice gardener needs to determine the unknown dimensions of the triangles.
- Use the figure to write an equation to show that the side lengths are proportional.
 - Solve the equation from part a. for x .
 - Do any of the solutions from part b. not make sense in the context of the problem? If yes, explain why.
 - What are the lengths of the unknown sides of the triangles?

Writing & Thinking

In simplifying rational expressions, the result is a rational or polynomial expression.

However, in solving equations with rational expressions, the goal is to find a value (or values) for the variable that will make the equation a true statement. Many students confuse these two ideas. To avoid confusing the techniques for adding and subtracting rational expressions with the techniques for solving equations, simplify the expression in part a. and solve the equation in part b. Explain, in your own words, the differences in your procedures. Assume no denominator has a value of 0.

72. a. $\frac{10}{x} + \frac{31}{x-1} + \frac{4x}{x-1}$

b. $\frac{10}{x} + \frac{31}{x-1} = \frac{4x}{x-1}$

73. a. $\frac{-4}{x^2-16} + \frac{x}{2x+8} - \frac{1}{4}$

b. $\frac{-4}{x^2-16} + \frac{x}{2x+8} = \frac{1}{4}$

74. a. $\frac{3x}{x^2-4} + \frac{5}{x+2} + \frac{2}{x-2}$

b. $\frac{3x}{x^2-4} + \frac{5}{x+2} = \frac{2}{x-2}$

75. a. $\frac{7}{5x} + \frac{2}{x-4} - \frac{3}{5x}$

b. $\frac{7}{5x} + \frac{2}{x-4} = \frac{3}{5x}$

76. a. $\frac{2}{x+9} - \frac{2}{x-9} + \frac{1}{2}$

b. $\frac{2}{x+9} - \frac{2}{x-9} = \frac{1}{2}$

$$\frac{210}{r} - \frac{210}{3r} = 4 \quad \text{The difference between their times is 4 hours.}$$

$$\frac{210}{r} - \frac{70}{r} = 4$$

$$\frac{210}{\cancel{r}} \cdot \cancel{r} - \frac{70}{\cancel{r}} \cdot \cancel{r} = 4 \cdot r$$

$$210 - 70 = 4r$$

$$140 = 4r$$

$$35 = r \quad \text{Speed of the freight train.}$$

$$105 = 3r \quad \text{Speed of the passenger train.}$$

Check

$$\text{Time for freight train} = \frac{210}{35} = 6 \text{ hours}$$

$$\text{Time for passenger train} = \frac{210}{105} = 2 \text{ hours}$$

$$6 - 2 = 4 \text{ hours difference in time}$$

The freight train travels 35 mph, and the passenger train travels 105 mph.

Now work margin exercise 6.**Margin Exercise Answers**

1. $\frac{5}{8}$ 2. $\frac{36}{5}$ hours or $7\frac{1}{5}$ hours 3. It takes the mom $\frac{9}{2}$ hours, or $4\frac{1}{2}$ hours, and her son takes 9 hours. 4. The pool will drain in $\frac{20}{3}$ hours, or $6\frac{2}{3}$ hours. 5. 2 mph
6. Commercial airplane: 360 mph; Private airplane: 180 mph

9.7 Exercises

Concept Check

Fill-in-the-Blank. Complete each sentence using information found in this section.

- For problems involving work, you should represent what part of the work is done in one _____ of _____.
- To solve any word problem, begin by _____ the problem carefully, possibly even several times.
- Once a potential solution for a word problem has been found, _____ the solution with the original problem to make sure it makes sense.
- The formula that relates distance, rate, and time is $d = rt$. This formula can be manipulated to represent the formula for rate, which is _____.
- When solving word problems, it may be helpful to draw a/an _____ or set up a/an _____ as a visual aid.

True/False. Determine whether each statement is true or false. If a statement is false, explain how it can be changed so the statement will be true. (**Note:** There may be more than one acceptable change.)

6. The first step in solving application problems is to assign a variable to the unknown value.
7. If the total amount of work took 5 hours to do, then $\frac{1}{5}$ of the work can be done in one hour.
8. If you know the distance and rate, you can use the formula $t = d - r$ to represent time.



Applications

Solve.

1. The sum of two numbers is 117, and they are in the ratio of 8 to 5. Find the two numbers.
2. If 4 is subtracted from a certain number and the difference is divided by 2, the result is 1 more than $\frac{1}{5}$ of the original number. Find the original number.
3. What number must be added to both the numerator and denominator of $\frac{16}{21}$ to make the resulting fraction equal to $\frac{5}{6}$?
4. Find the number that can be subtracted from both the numerator and denominator of the fraction $\frac{69}{102}$ so that the result is $\frac{5}{8}$.
5. The denominator of a fraction exceeds the numerator by 7. If the numerator is increased by 3 and the denominator is increased by 5, the resulting fraction is equal to $\frac{1}{2}$. Find the original fraction.
6. The numerator of a fraction exceeds the denominator by 5. If the numerator is decreased by 4 and the denominator is increased by 3, the resulting fraction is equal to $\frac{4}{5}$. Find the original fraction.
7. One number is $\frac{3}{4}$ of another number. Their sum is 63. Find the numbers.
8. The sum of two numbers is 24. If $\frac{2}{5}$ of the larger number is equal to $\frac{2}{3}$ of the smaller number, find the numbers.
9. One number exceeds another by 5. The sum of their reciprocals is equal to 19 divided by the product of the two numbers. Find the numbers.
10. One number is 3 less than another. The sum of their reciprocals is equal to 7 divided by the product of the two numbers. Find the numbers.

Solve the following word problems. Remember to check each solution with the wording of the original problem to make sure it is reasonable.

11. It takes Rosa, traveling at 30 mph, 30 minutes longer to go a certain distance than it takes Melody traveling at 50 mph. Find the distance traveled.
12.  It takes a plane, flying at 450 mph, 25 minutes longer to travel a certain distance than it takes a second plane to fly the same distance at 500 mph. Find the distance.

13. Kira needs 4 hours to complete the yard work. Her husband, Zackary, needs 6 hours to do the work. How long will the job take if they work together?
14.  In 1921, automated wrapping machines were used to aid in the wrapping of Hershey Kisses® in the Hershey chocolate factory. The machine could wrap the candies 100 times faster than a person could. Together the machine and the person could wrap a crate full of Hershey Kisses® in 5 minutes. How long would it take each of them working alone?
15. Ben's secretary can address the weekly newsletters in $4\frac{1}{2}$ hours. Charlie's secretary needs only 3 hours. How long will it take if they both work on the job?
16. Working together, Greg and Cindy can clean the snow from the driveway in 20 minutes. It would have taken Cindy 36 minutes working alone. How long would it have taken Greg alone?
17. A carpenter and his partner can put up a patio cover in $3\frac{3}{7}$ hours. If the partner needs 8 hours to complete the patio alone, how long would it take the carpenter working alone?
18.  Beth can travel 208 miles in the same length of time it takes Anna to travel 192 miles. If Beth's speed is 4 mph greater than Anna's, find both rates.
19. Charles can bike 32 miles in the same amount of time that his twin brother Chase can bike 24 miles. If Charles bikes 2 mph faster than Chase, how fast does each man bike?
20.  A commercial airliner can travel 750 miles in the same amount of time that it takes a private plane to travel 300 miles. The speed of the airliner is 60 mph more than twice the speed of the private plane. Find the speed of each aircraft.
21. Gabriela drives her car 350 miles and has an average of a certain speed. If the average speed had been 9 mph less, she could have traveled only 300 miles in the same length of time. What was her average speed?
22. A family travels 18 miles down river and returns. It takes 8 hours to make the round trip. Their rate in still water is twice the rate of the river's current. How long will the return trip take?
23. Cruise ships travel 5 times faster than sailboats (in optimal wind conditions). If it takes 16 hours longer for a sailboat (with optimal wind conditions) to travel 100 miles from Charleston, SC, to Savannah, GA, what is the speed of each boat?
24. An airplane can fly 650 mph in still air. If it can travel 2800 miles with the wind in the same time it can travel 2400 miles against the wind, find the wind speed.
25. A one-engine plane can fly 120 mph in still air. If it can fly 490 miles with a tailwind in the same time that it can fly 350 miles against a headwind, what is the speed of the wind? (**Note:** A tailwind increases the speed of the plane and a headwind decreases the speed of the plane.)
26. Using a small inlet pipe, it takes 9 hours to fill a pool. Using a large inlet pipe, it only takes 3 hours. If both are used simultaneously, how long will it take to fill the pool?

27. An inlet pipe on a swimming pool can be used to fill a pool in 36 hours. The drain pipe can be used to empty the pool in 40 hours. If the pool is $\frac{2}{3}$ filled using the inlet pipe and then the drain pipe is accidentally opened, how long from that time will it take to fill the pool?
28. A contractor hires two bulldozers to clear the trees from a 20-acre tract of land. One works twice as fast as the other. It takes them 3 days to clear the tract working together. How long would it take each of them alone?
29. John, Raul, and Denny, working together, can clean their bait and tackle store in 6 hours. Working alone, Raul takes twice as long to clean the store as John does. Denny needs three times as long as John does. How long would it take each man working alone?
30. Francois rode his jet ski 36 miles downstream and then 36 miles back. The round trip took $5\frac{1}{4}$ hours. Find the speed of the jet ski in still water and the speed of the current if the speed of the current is $\frac{1}{7}$ the speed of the jet ski.
31. Momence, IL, is 12 miles upstream on the same side of the river from Kankakee, IL, on the Kankakee River. A motorboat that can travel 8 mph in still water leaves Momence and travels downstream toward Kankakee. At the same time, another boat that can travel 10 mph leaves Kankakee and travels upstream toward Momence. Each boat completes the trip in the same amount of time. Find the rate of the current.
32. Samantha rides the ski lift to the top of Blue Mountain, a distance of $1\frac{3}{4}$ kilometers (a little more than 1 mile). She then skis directly down the slope. If she skis five times as fast as the lift travels and the total trip takes 45 minutes, find the rate at which she skis.
33. A local print shop has a big order of pamphlets to print, so they decide to use two of their printers for the one job. The newest printer can print the pamphlets four times as fast as the old printer. Working together the printers can complete the job in 4 hours. How many hours would it take each printer to print all of the pamphlets by itself?
- a. Use the table to set up a rational equation to describe the situation. Use the variable x to represent the time it takes the newest printer to complete the job.

| Printer | Time of Work (in Hours) | Part of Work Done in 1 Hour |
|----------|-------------------------|-----------------------------|
| Newest | | |
| Old | | |
| Together | | |

- b. Solve the equation from part a. for x .
- c. Use the solution from part b. to answer the question in the problem statement.

34. The Winston family is moving to another state. The family is driving to their new house in a car and all of their belongings are in a moving truck. The car is traveling at speed that is 9 miles per hour faster than the speed of the truck. After a certain amount of time, the family's car traveled 350 miles and the moving truck traveled 300 miles. What are the speeds of the car and the truck? Use the table to set up a rational equation to describe the situation. Use the variable x to represent the rate of the truck.

| Distance (d) | \div | Rate (r) | = | Time $\left(t = \frac{d}{r} \right)$ |
|------------------|--------|--------------|---|---------------------------------------|
| Car | | | | |
| Truck | | | | |

- a. Solve the equation from part a. for x .
- b. Use the solution from part b. to answer the question in the problem statement.
- c. If the Winston family's new home is 378 miles away, how long will it take the car and the truck to make the trip?

Writing & Thinking

35. If n is any integer, then $2n$ is an even integer and $2n + 1$ is an odd integer. Use these ideas to solve the following problems.
- a. Find two consecutive odd integers such that the sum of their reciprocals is $\frac{12}{35}$.
 - b. Find two consecutive even integers such that the sum of the first and the reciprocal of the second is $\frac{9}{4}$.

Margin Exercise Answers

1. $y = 4$ 2. 15 cm 3. $y = 2$ 4. 173 pounds 5. $z = 648$ 6. 400 feet 7. 200 cubic inches
8. 8000 pounds

9.8 Exercises

Concept Check

Fill-in-the-Blank. Complete each sentence using information found in this section.

1. If two variables are inversely proportional, an increase in the value of one variable must be accompanied by a/an _____ in the other.
2. If a variable varies (directly or inversely) with more than one other variable, this variation is said to be a/an _____ variation.
3. When two variables vary directly, an increase in one variable indicates a/an _____ in the other.
4. When two variables vary so that their product is constant, the two variables vary _____.
5. If there is a combined variation that is all direct variation, it is a/an _____ variation.
6. The letter k often represents the constant of _____.

True/False. Determine whether each statement is true or false. If a statement is false, explain how it can be changed so the statement will be true. (**Note:** There may be more than one acceptable change.)

7. The number of hamburgers eaten varies inversely with calories consumed.
8. The equation $y = \frac{k}{x}$ represents direct variation.
9. Distance and time varies directly, which means they are directly proportional.
10. The circumference of a circle varies directly with its radius.

Practice

Use the information given to find the unknown value. See Examples 1, 3, and 5.

1. If y varies directly as x , and $y = 3$ when $x = 9$, find y if $x = 7$.
2. If y is directly proportional to x^2 , and $y = 3$ when $x = 2$, what is y when $x = 8$?
3. If y varies inversely as x , and $y = 5$ when $x = 8$, find y if $x = 20$.
4. If y is inversely proportional to x , and $y = 5$ when $x = 4$, what is y when $x = 2$?
5. If y varies inversely as x^2 , and $y = -8$ when $x = 2$, find y if $x = 3$.
6. If y is inversely proportional to x^3 , and $y = 40$ when $x = \frac{1}{2}$, what is y when $x = \frac{1}{3}$?
7. If y is directly proportional to the square root of x , and $y = 6$ when $x = \frac{1}{4}$, what is y when $x = 9$?

8. If y is directly proportional to the square of x , and $y = 80$ when $x = 4$, what is y when $x = 6$?
9. z varies jointly as x and y , and $z = 60$ when $x = 2$ and $y = 3$. Find z if $x = 3$ and $y = 4$.
10. z varies jointly as x and y , and $z = -6$ when $x = 5$ and $y = 8$. Find z if $x = 12$ and $y = 15$.
11. z varies jointly as x and y^2 , and $z = 63$ when $x = 5$ and $y = 3$. Find z if $x = \frac{10}{3}$ and $y = 2$.
12. z varies jointly as x^2 and y , and $z = 20$ when $x = 2$ and $y = 3$. Find z if $x = 4$ and $y = \frac{7}{10}$.
13. z varies directly as x and inversely as y^2 . If $z = 5$ when $x = 1$ and $y = 2$, find z if $x = 2$ and $y = 1$.
14. z varies directly as x^3 and inversely as y^2 . If $z = 24$ when $x = 2$ and $y = 2$, find z if $x = 3$ and $y = 2$.
15. z varies directly as \sqrt{x} and inversely as y . If $z = 24$ when $x = 4$ and $y = 3$, find z if $x = 9$ and $y = 2$.
16. z varies directly as x^2 and inversely as \sqrt{y} . If $z = 108$ when $x = 6$ and $y = 4$, find z if $x = 4$ and $y = 9$.
17. s varies directly as the sum of r and t and inversely as w . If $s = 24$ when $r = 7$ and $t = 8$ and $w = 9$, find s if $r = 9$ and $t = 3$ and $w = 18$.
18. s varies directly as r and inversely as the difference of t and u . If $s = 36$ when $r = 12$ and $t = 9$ and $u = 6$, find s if $r = 18$ and $t = 11$ and $u = 8$.
19. L varies jointly as m and n and inversely as p . If $L = 6$ when $m = 7$ and $n = 8$ and $p = 12$, find L if $m = 15$ and $n = 14$ and $p = 10$.
20. W varies jointly as x and y and inversely as z . If $W = 10$ when $x = 6$ and $y = 5$ and $z = 2$, find W if $x = 12$ and $y = 6$ and $z = 3$.

Applications

Solve.

21. The distance a free-falling object falls is directly proportional to the square of the time it falls (before it hits the ground). If an object fell 256 feet in 4 seconds, how far would it have fallen by the end of 5 seconds?
22. The length a hanging spring stretches varies directly with the weight placed on the end. If a spring stretches 5 in. with a weight of 10 lb, how far will the spring stretch if the weight is increased to 12 lb?
23. The total price (P) of gasoline purchased varies directly as the number of gallons purchased. If 10 gallons are purchased for \$23.40, what will be the price of 15 gallons?

24.  Research shows that the value of gold and the value of the dollar are inversely proportional. In 2016, gold cost \$1200 per ounce and the dollar had a rating of 93 on the US dollar index. In 2017, the cost of gold was \$1300 per ounce. What was the 2017 rating of the dollar? (Round your answer to the nearest hundredth.)
25. The circumference of a circle varies directly as the diameter. A circular pizza pie with a diameter of 1 foot has a circumference of 3.14 feet. What will be the circumference of a pizza pie with a diameter of 1.5 feet?
26. The area of a circle varies directly as the square of its radius. A circular pizza pie with a radius of 6 in. has an area of 113.04 in.² What will be the area of a pizza pie with a radius of 9 in.?
27. Several triangles have the same area. In this set of triangles, the height and base are inversely proportional. In one such triangle, the height is 5 m and the base is 12 m. Find the height of the triangle in this set with a base of 10 m.

28.  If an astronaut weighs 250 pounds on the surface of the earth, what will the astronaut weigh 150 miles above the earth? Assume that the radius of the earth is 4000 miles, and round to the nearest tenth. (See Example 4.)

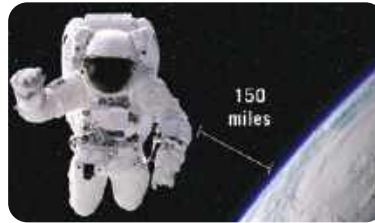

29.  The elongation (E) in a wire when a mass (m) is hung at its free end varies jointly as the attached mass and the length (l) of the wire and inversely as the cross-sectional area (A) of the wire. The elongation is 0.0055 cm when a mass of 120 g is attached to a wire 330 cm long with a cross-sectional area of 0.4 cm². Find the elongation if a mass of 160 g is attached to the same wire.

30.  When a mass of 240 oz is suspended by a wire 49 in. long whose cross-sectional area is 0.035 in.², the elongation of the wire is 0.016 in. Find the elongation if the same mass is suspended by a 28 in. wire of the same material with a cross-sectional area of 0.04 in.² (See Exercise 29.)

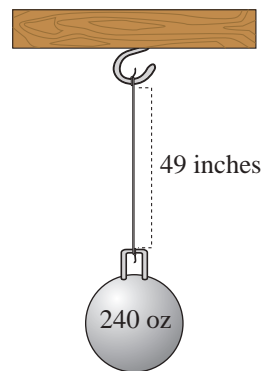

31. The safe load (L) of a wooden beam supported at both ends varies jointly as the width (w) and the square of the depth (d) and inversely as the length (l). A beam 4 in. wide, 6 in. deep, and 12 ft long supports a load of 4800 lb safely. What is the safe load of a beam of the same material that is 6 in. wide, 10 in. deep, and 15 ft long?
32. A wooden beam 2 in. wide, 8 in. deep, and 14 ft long holds up to 2400 lb. What load would a beam 3 in. wide, 6 in. deep, and 15 ft long, of the same material, support? (See Exercise 31.)

33. The gravitational force of attraction (F) between two bodies varies directly as the product of their masses (m_1 and m_2) and inversely as the square of the distance (d) between them. The gravitational force between a 5-kg mass and a 2-kg mass 1 m apart is 1.5×10^{-10} N. Find the force between a 24-kg mass and a 9-kg mass that are 6 m apart. (N represents a unit of force called a Newton.)
34. In Exercise 33, what is the force if the distance between the 24 kg mass and the 9 kg mass is cut in half?
35. The total price (P) of gasoline purchased varies directly as the number of gallons purchased. If 10 gallons are purchased for \$39.80, what will be the price of 15 gallons?
36. The distance that an object falls is directly proportional to the square of the time that has passed since the object started to fall. A rock falls a distance of 64 feet in 2 seconds. How long will it take the rock to fall a distance of 100 feet?
37. For a certain type of wooden beam that carries a load at its center, the safe load (SL) varies jointly as the width w and the cube of the depth (d) and inversely as the square of the length (l). A wooden beam that is 4 inches wide, 6 inches deep, and 12 feet long can safely support a load of 2400 pounds.
- Set up the variation equation.
 - Determine the constant of variation.
 - How much weight can a wooden beam that is 5 inches wide, 6 inches deep, and 10 feet long safely support?

Solve the following lifting force problems.

Lifting Force

The lifting force (or lift) (L) in pounds exerted by the atmosphere on the wings of an airplane is related to the area (A) of the wings in square feet and the speed (or velocity) (v) of the plane in miles per hour by the formula $L = kAv^2$, where k is the constant of variation.



38. If the lift is 9600 lb for a wing area of 120 ft² at a speed of 80 mph, find the lift of the same wing at a speed of 100 mph.
39. The lift for a wing of area 280 ft² is 34,300 lb when the plane is traveling at 210 mph. What is the lift if the speed is decreased to 180 mph?
40. The lift for a wing with an area of 144 ft² is 10,000 lb when the plane is traveling at 150 mph. What is the lift if the speed is decreased to 120 mph?
41. A plane traveling 140 mph with wing area 195 ft² has 12,500 lb of lift exerted on the wings. Find the lift for the same plane traveling at 168 mph.

Solve the following pressure problems.

Pressure

Boyle's Law states that if the temperature of a gas sample remains the same, the pressure (P) of the gas is related to the volume (V) by the formula

$$P = \frac{k}{V}, \text{ where } k \text{ is the constant of variation.}$$



42. A pressure of 1600 lb per ft² is exerted by 2 ft³ of air in a cylinder. If a piston is pushed into the cylinder until the pressure is 1800 lb per ft², what will be the volume of the air? Round to the nearest tenth.
43. The volume of gas in a container is 300 cm³ when the pressure on the gas is 20 g per cm². What will be the volume if the pressure is increased to 30 g per cm²?
44. The pressure in a canister of gas is 1360 g per in.² when the volume of gas is 5 in.³. If the volume is reduced to 4 in.³, what is the pressure?
45. A scuba diver is using a diving tank that can hold 6 liters of air. If the tank has a pressure rating of 220 bar when full, what is the pressure rating when the volume of gas is 4 liters?

Solve the following electricity problems.

Electricity

The resistance (R) (in ohms), in a wire is given by the formula $R = \frac{kL}{d^2}$, where k is the constant of variation, L is the length of the wire and d is the diameter.



46. The resistance of a wire 500 ft long with a diameter of 0.01 in. is 20 ohms. What is the resistance of a wire 1500 ft long with a diameter of 0.02 in.?
47. The resistance is 2.6 ohms when the diameter of a wire is 0.02 in. and the wire is 10 ft long. Find the resistance of the same type of wire with a diameter of 0.01 in. and a length of 5 ft.
48. Tristan's car stereo uses a 5-ft audio wire with diameter 0.025 in. and resistance of 1.6 ohms. What is the resistance of 8 ft of the same type of audio wire?
49. Nicole purchased a spool of wire with diameter 0.01 in. for the speakers in her home audio system. If the resistance of 15 ft of this wire is 6 ohms, what is the resistance of 25 ft of the wire?

Solve the following lever problems.

Levers

If a lever is balanced with weight on opposite sides of its balance point, then the following proportion exists:

$$\frac{W_1}{W_2} = \frac{L_2}{L_1} \text{ or } W_1L_1 = W_2L_2$$

where $L_1 + L_2 = L$, the total length of the lever.

50. How much weight can be raised at one end of a bar 8 ft long by the downward force of 60 lb when the balance point is $\frac{1}{2}$ ft from the unknown weight?
51. Where should the balance point of a bar 12 ft long be located if a 120-lb force is to raise a load weighing 960 lb?
52. Find the location of the balance point of a 25-ft board that can raise a 300-lb package with a downward force of 75 lb.
53. How much weight can be raised on one end of a 17-meter board by 90 kilograms, if the balance point is 5 meters from the unknown weight?

Writing & Thinking

54. Explain, in your own words, the meaning of the following terms.
 - a. Direct variation
 - b. Joint variation
 - c. Inverse variation
 - d. Combined variation

Discuss an example of each type of variation that you have observed in your daily life.

10.1 Exercises

Concept Check

Fill-in-the-Blank. Complete each sentence using information found in this section.

1. In a radical expression that appears to have no index, the index is understood to be ____.
2. When a number is multiplied by itself, the product is said to be that number's _____.
3. To reverse the process of squaring, find the _____ of the number.
4. If a is a nonnegative real number, then \sqrt{a} is the _____ square root of a .
5. In $\sqrt{102}$, the symbol $\sqrt{\quad}$ is called the _____ sign and 102 is the _____.
6. Square roots of negative numbers are not _____ numbers.

True/False. Determine whether each statement is true or false. If a statement is false, explain how it can be changed so the statement will be true. (**Note:** There may be more than one acceptable change.)

7. If a number is squared and the principal square root of the result is found, that square root is always equal to the original number.
8. There is no real number that can be a square root of a negative number.
9. The index is the number underneath the radical sign.
10. The cube root of -27 is a real number.

Practice

Simplify the following square roots and cube roots. See Examples 1, 2, and 4.

- | | | |
|----------------------|-------------------------------|------------------------|
| 1. $\sqrt{9}$ | 11. $\sqrt[3]{125}$ | 19. $\sqrt{0.04}$ |
| 2. $\sqrt{49}$ | 12. $\sqrt[3]{343}$ | 20. $\sqrt{0.0081}$ |
| 3. $\sqrt{81}$ | 13. $\sqrt[3]{216}$ | 21. $-\sqrt{100}$ |
| 4. $\sqrt{36}$ | 14. $\sqrt[3]{512}$ | 22. $-\sqrt{144}$ |
| 5. $\sqrt{289}$ | 15. $\sqrt{\frac{1}{4}}$ | 23. $-\sqrt{0.0016}$ |
| 6. $\sqrt{121}$ | 16. $\sqrt{\frac{9}{16}}$ | 24. $-\sqrt{0.000004}$ |
| 7. $\sqrt{169}$ | 17. $\sqrt[3]{\frac{27}{64}}$ | 25. $\sqrt[3]{-27}$ |
| 8. $\sqrt{361}$ | 18. $\sqrt[3]{\frac{1}{8}}$ | 26. $\sqrt[3]{-64}$ |
| 9. $\sqrt[3]{1}$ | | 27. $\sqrt[3]{-125}$ |
| 10. $\sqrt[3]{1000}$ | | 28. $\sqrt[3]{729}$ |

29. $\sqrt{\frac{9}{25}}$

30. $\sqrt{\frac{25}{81}}$

Estimates of radicals are given (rounded to the nearest ten-thousandth). Show that these are reasonable estimates. See Example 3.

31. $\sqrt{74} \approx 8.6023$

33. $\sqrt{32} \approx 5.6569$

32. $\sqrt{18} \approx 4.2426$

34. $\sqrt{110} \approx 10.4881$

In each of the following problems, determine the symbol, $<$, $>$, or $=$, that makes the statement true.

35. $\sqrt{16}$ ___ $\sqrt[3]{27}$

39. $\sqrt{4}$ ___ $\sqrt{4}$

36. $\sqrt[3]{64}$ ___ $\sqrt{125}$

40. $\sqrt{4}$ ___ $\sqrt[3]{8}$

37. $\sqrt{36}$ ___ $\sqrt[3]{343}$

41. $\sqrt[3]{343}$ ___ $\sqrt{49}$

38. $\sqrt[3]{125}$ ___ $\sqrt{64}$

42. $\sqrt{25}$ ___ $\sqrt[3]{27}$

Use your knowledge of square roots and cube roots to determine whether each number is rational, irrational, or not a real number.

43. $\sqrt{4}$

49. $\sqrt{-36}$

44. $\sqrt{17}$

50. $\sqrt[3]{-27}$

45. $\sqrt{169}$

51. $-\sqrt[3]{125}$

46. $\sqrt[3]{8}$

52. $\sqrt{-10}$

47. $\sqrt{\frac{2}{9}}$

53. $\sqrt{1.68}$

48. $-\sqrt{\frac{1}{4}}$

54. $\sqrt{5.29}$

 Use a calculator to find the value of each radical expression rounded to the nearest ten-thousandth. See Example 5.

55. $\sqrt{39}$

62. $6\sqrt{3}$

56. $\sqrt{150}$

63. $-2\sqrt{17}$

57. $\sqrt{6.23}$

64. $-3\sqrt{6}$

58. $\sqrt{9.6}$

65. $\sqrt[3]{18}$

59. $\sqrt{\frac{1}{5}}$

66. $\sqrt[3]{26}$

60. $\sqrt{\frac{3}{8}}$

67. $2\sqrt[3]{15}$

61. $4\sqrt{5}$

68. $3\sqrt[3]{11}$

Applications

Use the formula $s = \sqrt[3]{V}$, which relates the length of the sides of a cube and the volume V , to answer the following questions.



69.  The volume of a puzzle cube is 250 cubic inches. What is the length of one side? Round your answer to the nearest hundredth.
70. Three cubic blocks of different volumes were stacked on top of each other. The top block was 216 cubic centimeters. The middle block was 343 cubic centimeters, and the bottom block was 512 cubic centimeters. How tall was the stack of blocks?

Solve.

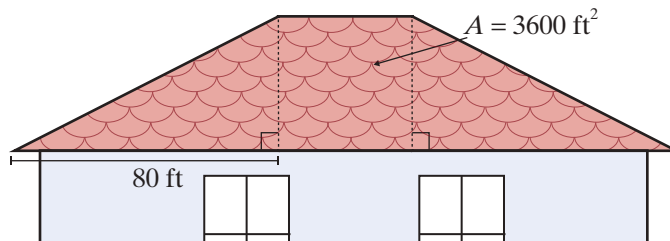
71. The area of a square tile is 16 square inches.
- How long are the sides of the square tile?
 - How many tiles would be needed for a four-foot-long and four-inch-high backsplash in a newly designed bathroom?
72.  Margaret needs to put a new gutter on one side of her roof. The shape of her roof is made up of two right triangles that are on opposite sides of a square. If the area of the square is 3600 ft^2 and the base of each of the triangles is 80 ft, what is the total length of the gutter she'll need to replace?



73. The volume of a volleyball is 523.33 cubic inches. Find the diameter of the ball using $\pi = 3.14$. Round your answer to the nearest inch. (**Note:** For a sphere, $V = \frac{4}{3}\pi r^3$.)
74. The volume of a child's building block is 64 cubic centimeters.
- Assuming the building block is a perfect cube, find the length of each side of the block.
 - If a child stacks 5 blocks directly on top of each other, find the height of the structure that is created.
75.  A pastry chef is making a batch of mini *petit fours*, which are little cakes, in the shape of cubes. To keep the nutritional value of each *petit four* consistent, the bakery manager wants each one to have a volume of 100 cm^3 . What should the side length be, to the nearest hundredth, for each *petit four*? (**Note:** For volume of a cube, $V = s^3$ where s = side length.)

76.  Isaac Newton fell asleep under an apple tree thinking about math. While he was sleeping, a squirrel knocked an apple off of a branch of the tree. The equation $t = \sqrt{\frac{2d}{9.8}}$ can be used to find the time t in seconds it takes for the apple to drop a certain distance d , where d is in meters. Round all answers to the nearest hundredth.
- If the apple was connected to a branch 2 m above Newton's head, how long would it take before the apple hit Newton's head?
 - If the squirrel knocked a second apple off a branch that was 5 m above Newton's head, how long would it take before the apple hit Newton's head?
 - Suppose the second apple missed Newton's head and landed on the ground instead. If Newton's head was 0.8 m above the ground, how long would it take for the apple to hit the ground?
77.  A person's Body Mass Index (BMI) is determined by the formula $B = \frac{m}{h^2}$ where B is the BMI, m is the person's mass in kilograms, and h is the person's height in meters. Having a BMI between 18.5 and 25 is considered optimal. To find a person's height based on their BMI and mass, the formula can be rearranged to $h = \sqrt{\frac{m}{B}}$. Round all answers to the nearest tenth.
- Elias has a mass of 60.7 kg and a BMI of 21. What is Elias's height?
 - Fatima has a mass of 69.0 kg and a BMI of 27. What is Fatima's height?
 - Tobias has a mass of 69.0 kg and a BMI of 21. What is Tobias's height?
78.  A square flower garden covers an area of 68 square feet.
- What is the approximate length of each side of the square? Round your answer to the nearest tenth.
 - Use the answer from part a. to determine the amount of edging material needed to create a border around the flower garden.
 - The edging material costs \$1.39 per foot. How much will the amount of edging material from part b. cost? Round your answer to the nearest cent.

79.  Barbara's Bombtastic Bakery is installing a corner display stand for custom decorated cakes. The top of the display stand is designed in the shape of a right triangle, as shown.

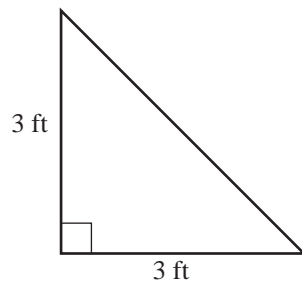

- What is the length of the longest side of the display stand? Round your answer to the nearest tenth.
 - The top of the display has a decorative edge around all three sides to prevent the cakes from falling off. How much edging is required for the display?
 - If the top of the display stand is to be covered by square tiles that have a side length of 6 inches, how many tiles will be needed?
80.  A glass company makes a paperweight in the shape of a cube that has a volume of 91.125 cubic inches.
- What is the length of each side of the cube?
 - What is the area of the base of the cube?
 - What is the surface area of the cube?

Writing & Thinking

- Discuss, in your own words, why the square root of a negative number is not a real number.
- Discuss, in your own words, why the cube root of a negative number is a negative number.

$$\text{b. } \sqrt[3]{-40x^4y^{13}} = \sqrt[3]{-8x^3y^{12}} \cdot \sqrt[3]{5xy} = -2xy^4\sqrt[3]{5xy}$$

8 is a perfect cube and the exponents on the variables are separated so that one exponent on each variable is divisible by 3.

$$\text{c. } \sqrt[3]{250a^8b^{11}} = \sqrt[3]{125a^6b^9} \cdot \sqrt[3]{2a^2b^2} = 5a^2b^3\sqrt[3]{2a^2b^2}$$

125 is a perfect cube and the exponents on the variables are separated so that one exponent on each variable is divisible by 3.

Now work margin exercise 4.

Margin Exercise Answers

1. a. $7\sqrt{2}$ b. $3\sqrt{5}$ c. $\frac{2\sqrt{3}}{5}$ 2. a. $6z$ b. $5b\sqrt{3}$ c. $3cd\sqrt{5}$ 3. a. $4x^4$ b. $10xy\sqrt{xy}$
 c. $2x^4y^6\sqrt{3}$ d. $\frac{5z^9}{y^4}$ 4. a. $2z^3\sqrt{6}$ b. $-3a^2b^4\sqrt[3]{3a^2}$ c. $7x^2y^3\sqrt[3]{2y^2}$

10.2 Exercises

Concept Check

Fill-in-the-Blank. Complete each sentence using information found in this section.

- A cube root is considered in simplest form when the radicand has no perfect cube as a/an _____.
- When simplifying with cube roots, look for variables with exponents that are multiples of ____.
- To find the square root of an expression with even exponents, divide the exponents by ____.
- A square root is in simplest form when the radicand has no _____ _____ as a factor.
- If a and b are positive real numbers, then $\sqrt{ab} = \underline{\hspace{2cm}}$.
- If a and b are positive real numbers, then $\sqrt{\frac{a}{b}} = \underline{\hspace{2cm}}$.

True/False. Determine whether each statement is true or false. If a statement is false, explain how it can be changed so the statement will be true. (**Note:** There may be more than one acceptable change.)

- Any variable term with an exponent of 5 has a perfect cube factor within that variable term.
- The simplest form of a radical expression can be found by using prime factorization.
- If x is a real number, then $\sqrt{x^2} = x$.
- The term $7b^3\sqrt[3]{6c^2}$ is in simplified form.

Practice

Simplify each of the following radical expressions. Assume that all variables represent positive real numbers.

- | | | |
|-------------------------------|---|---|
| 1. $\sqrt{12}$ | 22. $\sqrt{20x^{15}y^3}$ | 42. $\sqrt[3]{-125}$ |
| 2. $-\sqrt{45}$ | 23. $\sqrt{125x^3y^6}$ | 43. $\sqrt[3]{-128}$ |
| 3. $\sqrt{288}$ | 24. $\sqrt{8x^5y^4}$ | 44. $\sqrt[3]{-250}$ |
| 4. $-\sqrt{63}$ | 25. $-\sqrt{18x^2y^2}$ | 45. $\sqrt[3]{125x^4}$ |
| 5. $-\sqrt{72}$ | 26. $-\sqrt{32x^4y^8}$ | 46. $\sqrt[3]{64a^{12}}$ |
| 6. $\sqrt{98}$ | 27. $\sqrt{12ab^2c^3}$ | 47. $\sqrt[3]{-8x^8}$ |
| 7. $-\sqrt{56}$ | 28. $\sqrt{45a^2b^3c^4}$ | 48. $\sqrt[3]{-512a^5}$ |
| 8. $\sqrt{162}$ | 29. $\sqrt{75x^4y^6z^8}$ | 49. $\sqrt[3]{72a^6b^4}$ |
| 9. $-\sqrt{125}$ | 30. $\sqrt{200x^2y^2z^2}$ | 50. $\sqrt[3]{108ab^9}$ |
| 10. $-\sqrt{121}$ | 31. $\sqrt{\frac{5x^4}{9}}$ | 51. $\sqrt[3]{216x^6y^5}$ |
| 11. $\sqrt{\frac{1}{4}}$ | 32. $-\sqrt{\frac{7y^6}{16x^4}}$ | 52. $\sqrt[3]{64x^9y^2}$ |
| 12. $\sqrt{\frac{32}{49}}$ | 33. $\sqrt{\frac{32a^5}{81b^{16}}}$ | 53. $\sqrt[3]{24x^5y^7z^9}$ |
| 13. $-\sqrt{\frac{11}{64}}$ | 34. $\sqrt{\frac{75x^8}{121y^{12}}}$ | 54. $\sqrt[3]{250x^6y^9z^{15}}$ |
| 14. $-\sqrt{\frac{125}{100}}$ | 35. $\sqrt{\frac{200x^8}{289}}$ | 55. $\frac{\sqrt[3]{81}}{6}$ |
| 15. $\sqrt{\frac{28}{25}}$ | 36. $\sqrt{\frac{32x^{15}y^{10}}{169}}$ | 56. $\frac{\sqrt[3]{192}}{10}$ |
| 16. $\sqrt{\frac{147}{100}}$ | 37. $\sqrt[3]{216}$ | 57. $\sqrt[3]{\frac{375}{8}}$ |
| 17. $\sqrt{36x^2}$ | 38. $\sqrt[3]{1}$ | 58. $\sqrt[3]{\frac{-48}{125}}$ |
| 18. $\sqrt{49y^2}$ | 39. $\sqrt[3]{56}$ | 59. $\sqrt[3]{\frac{125y^{12}}{27x^6}}$ |
| 19. $\sqrt{8x^3}$ | 40. $\sqrt[3]{72}$ | 60. $\sqrt[3]{\frac{x^6z^3}{64y^9}}$ |
| 20. $\sqrt{18a^5}$ | 41. $\sqrt[3]{-1}$ | |
| 21. $\sqrt{24x^{11}y^2}$ | | |

Applications

Use the following two formulas associated with electricity to answer Exercises 61–64.

$$I = \sqrt{\frac{P}{R}} \quad \begin{array}{l} P = \text{power (in watts)} \\ I = \text{current (in amperes)} \end{array}$$

$$E = \sqrt{PR} \quad \begin{array}{l} E = \text{voltage (in volts)} \\ R = \text{resistance (in ohms, } \Omega) \end{array}$$

61. What is the current in amperes of a light bulb that produces 150 watts of power and has a 25Ω resistance?
62. If a light bulb has a resistance of 30Ω and produces 90 watts of power, what is its current in amperes?
63. How many volts of electricity would Meghan need to produce 48Ω of resistance from a 300 watt lamp?
64. A 5000Ω resistor is rated at 2.5 watts. What is the maximum voltage of electricity that should be connected across it?
65.  A nut company is determining how to package their new type of party mix. The marketing department is experimenting with different-sized cans for the party mix packaging. The designers use the equation $r = \sqrt{\frac{V}{h\pi}}$ to determine the radius of the can for a certain height h and volume V . The company decides they want the can to have a volume of $1200\pi \text{ cm}^3$. Keep your answers in simplified radical form.
 - a. Find the radius of the can if the height is 12 cm.
 - b. Find the radius of the can if the height is 10 cm.
 - c. Find the radius of the can if the height is 8 cm.

Writing & Thinking

66. Under what conditions is the expression \sqrt{a} not a real number?
67. Explain why the expression $\sqrt[3]{y}$ is a real number regardless of whether $y > 0$, $y < 0$, or $y = 0$.

Step 4: Press **ENTER**.

The display should appear as follows.

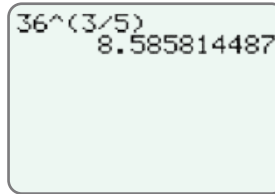

36^(3/5)
8.585814487

Now work margin exercise 5.

Margin Exercise Answers

1. a. 6 b. 2 c. -3 d. 0.2 e. not a real number 2. a. $\sqrt[5]{x^2}$ b. $8\sqrt[7]{z^6}$ c. $-\sqrt[4]{b^5}$ d. $x^{\frac{5}{7}}$ e. $3s^{\frac{1}{2}}$
 f. $-5^{\frac{1}{4}}$ 3. a. $x^{\frac{7}{12}}$ b. $\frac{1}{a^{\frac{2}{9}}}$ c. $81b^{\frac{4}{5}}$ d. $\frac{z^{\frac{2}{9}}}{8}$ e. not a real number f. 4 4. a. $\sqrt[10]{x}$ b. $\sqrt[4]{x^3}$
 c. $x^{\sqrt[3]{x}}$ 5. a. 256 b. 22.52722735

10.3 Exercises

Concept Check

Fill-in-the-Blank. Complete each sentence using information found in this section.

- The expression $\sqrt[n]{a}$ is called a/an _____ expression, and n is called the _____.
- In the expression $-\sqrt[5]{3}$, the coefficient is ____ and the index is ____.
- The expression \sqrt{a} would be rewritten as ____ in exponential notation.
- An equivalent way to write $a^{\frac{m}{n}}$ is $\left(\frac{1}{a}\right)^m$ or _____.
- The expression $a^{\frac{1}{3}}$ can be written as ____ in radical notation.
- For n^{th} roots, if $b = \sqrt[n]{a}$, then $b =$ _____.

True/False. Determine whether each statement is true or false. If a statement is false, explain how it can be changed so the statement will be true. (**Note:** There may be more than one acceptable change.)

- The same rules for exponents apply to both integer exponents and rational exponents.
- If the cube root of 7 were to be converted into exponential notation it would be $\sqrt[3]{7}$.
- Any expression to the power 0, such as $\left(\sqrt[4]{x}\right)^0$, is equal to 1.
- The expression $y^{\frac{1}{2}}$ can be rewritten in radical notation as $\sqrt{y^2}$.

Practice

Write an equivalent expression using radical notation. See Example 2.

1. $8^{\frac{1}{3}}$

3. $-x^{\frac{1}{6}}$

5. $(2z)^{\frac{2}{5}}$

2. $5^{\frac{1}{2}}$

4. $4y^{\frac{3}{4}}$

Write an equivalent expression using exponential notation. See Example 2.

6. $\sqrt{3}$

8. $4\sqrt[3]{x^2}$

10. $\sqrt[5]{16x^2}$

7. $\sqrt[3]{13}$

9. $\sqrt[3]{-9}$

Simplify each numerical expression. See Example 3.

11. $9^{\frac{1}{2}}$

21. $\left(\frac{9}{49}\right)^{\frac{1}{2}}$

29. $\left(-\frac{1}{32}\right)^{\frac{2}{5}}$

12. $121^{\frac{1}{2}}$

22. $\left(\frac{225}{144}\right)^{\frac{1}{2}}$

30. $\left(\frac{27}{64}\right)^{\frac{2}{3}}$

13. $100^{-\frac{1}{2}}$

23. $64^{\frac{2}{3}}$

31. $3 \cdot 16^{-\frac{3}{4}}$

14. $25^{-\frac{1}{2}}$

24. $8^{-\frac{2}{3}}$

32. $2 \cdot 25^{-\frac{1}{2}}$

15. $-64^{\frac{3}{2}}$

25. $(-216)^{-\frac{1}{3}}$

33. $-100^{-\frac{3}{2}}$

16. $(-64)^{\frac{3}{2}}$

26. $(-125)^{\frac{1}{3}}$

34. $-49^{-\frac{5}{2}}$

17. $(-64)^{\frac{1}{3}}$

27. $\left(\frac{8}{125}\right)^{-\frac{1}{3}}$

35. $\left[\left(\frac{1}{32}\right)^{\frac{2}{5}}\right]^{-3}$

18. $-(64)^{\frac{1}{3}}$

28. $-\left(\frac{16}{81}\right)^{-\frac{3}{4}}$

36. $\left[(-27)^{\frac{2}{3}}\right]^{-2}$

19. $\left(-\frac{4}{25}\right)^{\frac{1}{2}}$

20. $-\left(\frac{4}{25}\right)^{\frac{1}{2}}$

 Use a graphing calculator to find the value of each numerical expression accurate to the nearest ten-thousandth, if necessary. See Example 5.

37. $25^{\frac{2}{3}}$

42. $2000^{\frac{2}{3}}$

47. $\sqrt[4]{0.0025}$

38. $81^{\frac{7}{4}}$

43. $24^{-\frac{3}{4}}$

48. $\sqrt[5]{0.00032}$

39. $100^{\frac{7}{2}}$

44. $18^{-\frac{3}{2}}$

49. $\sqrt[4]{3600}$

40. $100^{\frac{1}{3}}$

45. $\sqrt[2]{72}$

50. $\sqrt[6]{4500}$

41. $250^{\frac{5}{6}}$

46. $\sqrt[8]{63}$

51. $\sqrt[5]{35.4}$

52. $\sqrt[10]{1.8}$

Simplify each algebraic expression. Assume that all variables represent positive real numbers. Leave the answers in exponential notation. See Example 3.

53. $(2x^{\frac{1}{3}})^3$

54. $(3x^{\frac{1}{2}})^4$

55. $(9a^4)^{-\frac{1}{2}}$

56. $(16a^3)^{-\frac{1}{4}}$

57. $8x^2 \cdot x^{\frac{1}{2}}$

58. $3x^3 \cdot x^{\frac{2}{3}}$

59. $5a^2 \cdot a^{-\frac{1}{3}} \cdot a^{\frac{1}{2}}$

60. $a^{\frac{2}{3}} \cdot a^{-\frac{3}{5}} \cdot a^0$

61. $\frac{x^{\frac{3}{4}}}{x^{\frac{1}{6}}}$

62. $\frac{a^{\frac{2}{3}}}{a^{\frac{1}{9}}}$

63. $\frac{x^{\frac{2}{5}}}{x^{-\frac{1}{10}}}$

64. $\frac{a^{\frac{1}{2}}}{a^{-\frac{2}{3}}}$

65. $\frac{a^{\frac{3}{4}} \cdot a^{\frac{1}{8}}}{a^2}$

66. $\frac{x^{\frac{2}{3}} \cdot x^{\frac{4}{3}}}{x^2}$

67. $\frac{a^{\frac{1}{2}} \cdot a^{-\frac{3}{4}}}{a^{-\frac{1}{2}}}$

68. $\frac{x^{\frac{2}{3}} x^{-1}}{x^{-\frac{3}{2}}}$

69. $\frac{a^{\frac{3}{2}} b^{\frac{4}{5}}}{a^{-\frac{1}{2}} b^2}$

70. $\frac{a^{\frac{3}{4}} b^{-\frac{1}{3}}}{a^{\frac{3}{2}} b^{\frac{1}{6}}}$

71. $(2x^{\frac{1}{2}} y^{\frac{1}{3}})^3$

72. $(a^{\frac{1}{2}} a^{\frac{1}{3}})^6$

73. $(4x^{-\frac{3}{4}} y^{\frac{1}{5}})^{-2}$

74. $(81a^{-8} b^2)^{-\frac{1}{4}}$

75. $(-x^3 y^6 z^{-6})^{\frac{2}{3}}$

76. $(9x^2 y^{-4} z^{-3})^{\frac{3}{2}}$

77. $(\frac{x^2 y^{-3}}{z^4})^{-\frac{1}{2}}$

78. $(\frac{27a^3 b^6}{c^9})^{-\frac{1}{3}}$

79. $(\frac{16a^{-4} b^3}{c^4})^{\frac{3}{4}}$

80. $(\frac{-27a^2 b^3}{c^{-3}})^{\frac{1}{3}}$

81. $\frac{(x^{\frac{1}{4}} y^{\frac{1}{2}})^3}{x^{\frac{1}{2}} y^{\frac{1}{4}}}$

82. $\frac{(x^{\frac{1}{2}} y)^{-\frac{1}{3}}}{x^{\frac{2}{3}} y^{-1}}$

83. $\frac{(8x^2 y)^{-\frac{1}{3}}}{(5x^{\frac{1}{3}} y^{-\frac{1}{2}})^2}$

84. $\frac{(25a^4 b^{-1})^{\frac{1}{2}}}{(2a^{\frac{1}{5}} b^{\frac{3}{5}})^3}$

$$85. \left(\frac{a^{-3}b^{\frac{1}{3}}}{a^{\frac{1}{2}}b} \right)^{\frac{1}{2}} \cdot \left(\frac{ab^{\frac{1}{2}}}{a^{-\frac{2}{3}}b^{-1}} \right)^{\frac{1}{2}}$$

$$86. \left(\frac{x^2y^{\frac{1}{3}}}{x^{\frac{1}{2}}y^{\frac{3}{2}}} \right)^{\frac{1}{2}} \cdot \left(\frac{x^{-\frac{1}{2}}y^{\frac{2}{3}}}{x^{-1}y^{\frac{3}{4}}} \right)^2$$

$$87. \frac{\left(27xy^{\frac{1}{2}}\right)^{\frac{1}{3}} \cdot \left(x^{\frac{1}{2}}y\right)^{\frac{1}{6}}}{\left(25x^{-\frac{1}{2}}y\right)^{\frac{1}{2}} \cdot \left(16x^{\frac{1}{3}}y\right)^{\frac{1}{2}}}$$

$$88. \frac{\left(4a^{-6}b\right)^{\frac{1}{2}} \cdot \left(49a^4b^3\right)^{-\frac{1}{2}}}{\left(7a^2b^3\right)^{-1} \cdot \left(64a^{-3}b^6\right)^{\frac{2}{3}}}$$

Simplify each expression by first changing it into an equivalent expression with rational exponents. Rewrite the answer in simplified radical form. Assume that all variables represent positive real numbers. See Example 4.

$$89. \sqrt{x} \cdot \sqrt[3]{x}$$

$$90. \sqrt[3]{x^2} \cdot \sqrt[5]{x^3}$$

$$91. \frac{\sqrt[4]{y^3}}{\sqrt[6]{y}}$$

$$92. \frac{\sqrt[3]{x^4}}{\sqrt[4]{x}}$$

$$93. \frac{\sqrt[3]{x^2} \sqrt[5]{x^6}}{\sqrt{x^3}}$$

$$94. \frac{a^4 \sqrt{a}}{\sqrt[3]{a} \sqrt{a}}$$

$$95. \sqrt[3]{\sqrt{y}}$$

$$96. \sqrt[5]{\sqrt{x}}$$

$$97. \sqrt[3]{\sqrt[3]{x}}$$

$$98. \sqrt{\sqrt{a}}$$

$$99. \sqrt[15]{(7a)^5}$$

$$100. \sqrt[21]{(3x)^7}$$

$$101. \sqrt[4]{\sqrt[3]{\sqrt{x}}}$$

$$102. \sqrt[5]{\sqrt[4]{\sqrt[3]{x}}}$$

$$103. \left(\sqrt[3]{a^4bc^2}\right)^{15}$$

$$104. \left(\sqrt[4]{a^3b^6c}\right)^{12}$$

Applications

Solve.

- 105.** According to Kepler's Law of Periods, the square of the orbital period of a planet is directly proportional to the cube of the semi-major axis of its orbit, or the cube of the planet's maximum distance from the sun. Writing this relationship as an equation solved for the period of a planet gives us $p = d^{\frac{3}{2}}$ where p is the orbital period of a planet represented in Earth years and d is the planet's semi-major axis represented in astronomical units (AU). Using the given equation, if the planet Mercury has a semi-major axis of 0.39 AU, what is the orbital period of Mercury in Earth years? Round your answer to the nearest hundredth.

106. The orbital period of Saturn is about 29.5 Earth years.
- Solving Kepler's Law of Periods (see Exercise 105) for the planet's maximum distance from the sun, gives the equation $d = p^{\frac{2}{3}}$. Use this equation to calculate the maximum distance away from the sun that Saturn reaches in astronomical units. Round your answer to the nearest hundredth.
 - Given that Earth's semi-major axis is 1 AU, about how many times further from the sun does Saturn travel than Earth?

107. The width of a rectangle is $\sqrt[3]{64^2}$ ft and the length is $216^{\frac{2}{3}}$ ft. What is the area of the rectangle?

108.  The motion of a simple pendulum is represented by the following equation, where T = the pendulum period, L = length, and g = acceleration of gravity.

$$T = 2\pi\sqrt{\frac{L}{g}}$$

If the length of the pendulum is $320^{\frac{2}{3}}$ meters and the acceleration of gravity is equal to 9.8 meters per seconds squared, what is the period of the pendulum? Use $\pi = 3.14$ and round your answer to the nearest hundredth.

109.  A crew of construction workers are disassembling the inside of a building and dropping things into dumpsters at the base of the building. The equation $v_a = \frac{(64d)^{\frac{1}{2}}}{2}$ is used to find the average velocity, or speed, in feet per second of an object that has fallen a distance of d feet.
- What is the average velocity, to the nearest hundredth, of a lighting fixture that fell 25 feet?
 - What is the average velocity, to the nearest hundredth, of a ceiling tile that fell 80 feet?

110.  Isaac Newton fell asleep under an apple tree thinking about math. While he was sleeping, a squirrel knocked an apple off of a branch of the tree. The equation $v = (19.8d)^{\frac{1}{2}}$ can be used to find the velocity v , in meters per second, of the apple after dropping a distance d , where d is in meters.
- If the apple was connected to a branch 2 m above Newton's head, what was the velocity of the apple, to the nearest hundredth, when it hit Newton's head?
 - If the squirrel knocked a second apple off a branch that was 5 m above Newton's head, what was the velocity of the apple, to the nearest hundredth, when it hit Newton's head?
 - Suppose the second apple missed Newton's head and landed on the ground instead. If Newton's head was 0.8 m above the ground, what was the velocity of the apple, to the nearest hundredth, when it hit the ground?

- 111.** An amusement park is creating signs to indicate the velocity of the roller coaster car on certain hills of the most popular rides. A roller coaster car gains kinetic energy as it goes down a hill. The velocity, or speed, of an object in kilometers per hour (kph) can be determined by $V = \left(\frac{2k}{m}\right)^{\frac{1}{2}}$, where k is the kinetic energy of the object in joules (J) and m is the mass of the object in kilograms (kg).
- For the most popular roller coaster, the car has a mass of 300 kg and the car has a kinetic energy of 375,000 J on the first hill. What velocity does the car obtain on the first hill?
 - For the second most popular roller coaster, the car has a mass of 350 kg and the car has a kinetic energy of 70,000 on the first hill. What velocity does the car obtain on the first hill?

Writing & Thinking

- 112.** Is $\sqrt[5]{a} \cdot \sqrt{a}$ the same as $\sqrt[5]{a^2}$? Explain why or why not.
- 113.** Assume that x represents a positive real number. Describe what kind of number the exponent n must be for x^n to mean
- a product.
 - a quotient.
 - 1.
 - a radical state.

10.4 Exercises

Concept Check

Fill-in-the-Blank. Complete each sentence using information found in this section.

1. Like radicals have the same _____ and radicand or they can be simplified so that they do.
2. Sometimes two or more radicals that do not appear to be like radicals can be _____ so that they are like radicals.

True/False. Determine whether each statement is true or false. If a statement is false, explain how it can be changed so the statement will be true. (**Note:** There may be more than one acceptable change.)

3. The radicals \sqrt{a} and $\sqrt[3]{a}$ are like radicals.
4. The radicals \sqrt{a} and $3\sqrt{a}$ are like radicals.
5. The sum $4\sqrt{3} + 8\sqrt{5}$ cannot be simplified.

Practice

Simplify the following radical expressions. Assume that all variables represent positive real numbers.

- | | |
|--|--|
| 1. $3\sqrt{2} + 5\sqrt{2}$ | 16. $\sqrt{5} + \sqrt{4} - 2\sqrt{5} + 6$ |
| 2. $7\sqrt{3} - 2\sqrt{3}$ | 17. $2\sqrt{a} + 7\sqrt{b} - 6\sqrt{a} + \sqrt{b}$ |
| 3. $4\sqrt{11} - 3\sqrt{11}$ | 18. $4\sqrt{x} - 3\sqrt{x} + 2\sqrt{y} + 2\sqrt{x}$ |
| 4. $6\sqrt{5} + \sqrt{5}$ | 19. $6\sqrt[3]{x} - 4\sqrt[3]{y} + 7\sqrt[3]{x} + 2\sqrt[3]{y}$ |
| 5. $8\sqrt{10} - 11\sqrt{10}$ | 20. $5\sqrt[3]{x} + 9\sqrt[3]{y} - 10\sqrt[3]{y} + 4\sqrt[3]{x}$ |
| 6. $6\sqrt{17} - 9\sqrt{17}$ | 21. $\sqrt{12} + \sqrt{27}$ |
| 7. $4\sqrt[3]{3} + 9\sqrt[3]{3}$ | 22. $\sqrt{32} - \sqrt{18}$ |
| 8. $11\sqrt[3]{14} - 6\sqrt[3]{14}$ | 23. $3\sqrt{5} - \sqrt{45}$ |
| 9. $6\sqrt{11} - 5\sqrt{11} - 2\sqrt{11}$ | 24. $2\sqrt{7} + 5\sqrt{28}$ |
| 10. $\sqrt{7} + 6\sqrt{7} - 2\sqrt{7}$ | 25. $3\sqrt[3]{54} + 8\sqrt[3]{2}$ |
| 11. $\sqrt{a} + 4\sqrt{a} - 2\sqrt{a}$ | 26. $2\sqrt[3]{128} + 5\sqrt[3]{-54}$ |
| 12. $2\sqrt{x} - 3\sqrt{x} + 7\sqrt{x}$ | 27. $\sqrt{50} - \sqrt{18} - 3\sqrt{12}$ |
| 13. $5\sqrt{x} + 3\sqrt{x} - \sqrt{x}$ | 28. $2\sqrt{48} - \sqrt{54} + \sqrt{27}$ |
| 14. $6\sqrt{xy} - 10\sqrt{xy} + \sqrt{xy}$ | 29. $2\sqrt{20} - \sqrt{45} + \sqrt{36}$ |
| 15. $3\sqrt{2} + 5\sqrt{3} - 2\sqrt{3} + \sqrt{2}$ | 30. $\sqrt{18} - 2\sqrt{12} + 5\sqrt{2}$ |

31. $\sqrt{8} - 2\sqrt{3} + \sqrt{27} - \sqrt{72}$
32. $\sqrt{80} + \sqrt{8} - \sqrt{45} + \sqrt{50}$
33. $5\sqrt[3]{16} - 4\sqrt[3]{24} + \sqrt[3]{-250}$
34. $\sqrt[3]{192} - 2\sqrt[3]{128} + \sqrt[3]{-81}$
35. $6\sqrt{2x} - \sqrt{8x}$
36. $5\sqrt{3x} + 2\sqrt{12x}$
37. $5y\sqrt{2y} - y\sqrt{18y}$
38. $9x\sqrt{xy} - x\sqrt{16xy}$
39. $4x\sqrt{3xy} - x\sqrt{12xy} - 2x\sqrt{27xy}$
40. $x\sqrt{32x} - x\sqrt{50x} + 2x\sqrt{18x}$
41. $\sqrt{36x^3} + \sqrt{81x^3}$
42. $\sqrt{4a^2b} + \sqrt{9a^2b}$
43. $\sqrt{16x^3y^4} - \sqrt{25x^3y^4}$
44. $\sqrt{72x^{12}y^{15}} + \sqrt{18x^{12}y^{15}} + \sqrt{2x^{12}y^{15}}$
45. $\sqrt{12x^{10}y^{20}} + \sqrt{27x^{10}y^{20}} - \sqrt{3x^{10}y^{20}}$
46. $\sqrt[3]{8a^{12}} + \sqrt[3]{1000a^{12}}$
47. $\sqrt[3]{-27x^{24}y^6} + \sqrt[3]{-125x^{24}y^6}$
48. $\sqrt[3]{27a^{15}b} + \sqrt[3]{8a^{15}b} + \sqrt[3]{64a^{15}b}$
49. $\sqrt[3]{-16x^9y^{12}} - \sqrt[3]{16x^{12}y^9} + \sqrt[3]{54x^3y^6}$
50. $\sqrt[3]{54x^{13}y^3} + \sqrt[3]{8x^{23}y^6} + \sqrt[3]{3x^{13}y^3}$

Applications

Solve.

51. For a complete radio circuit, $d = \sqrt{2g} + \sqrt{2h}$, where d equals the visual horizon distance and g and h are the heights of the radio antennas at the respective stations. What is d when $g = 75$ ft and $h = 85$ ft?

52. Mary is making a tile decoration for her wall. Using square tiles of different sizes, Mary created one decoration that is five tiles across, with sides touching. The first tile is 10 in.^2 , the second is 20 in.^2 , the third is 30 in.^2 , the fourth is 20 in.^2 , and the fifth is 10 in.^2 . What is the length of the decoration?

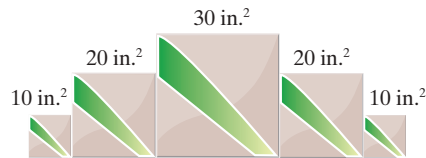

53. Josue earns $\sqrt{32t}$ dollars when he works t hours. His roommate, Eric, earns $\sqrt{18t}$ dollars when he works t hours.
- Find an expression that represents the total income that the two roommates earn after they each work t hours.
 - Find an expression that represents how much more money Josue will earn than Eric after they each work t hours.

Writing & Thinking

Explain the error(s) made in each solution below.

$$\begin{aligned} 54. \quad \sqrt{16} + \sqrt{48} &= \sqrt{16+48} \\ &= \sqrt{64} \\ &= 8 \end{aligned}$$

$$\begin{aligned} 55. \quad \sqrt[3]{-125} + \sqrt[3]{98} &= \sqrt[3]{-125+98} \\ &= \sqrt[3]{-27} \\ &= 3 \end{aligned}$$

D Evaluating Radical Expressions with a Graphing Calculator

Techniques for using a TI-84 Plus graphing calculator to evaluate radical expressions were illustrated in Section 10.1. These same basic techniques are used to evaluate numerical expressions that contain sums, differences, products, and quotients of radicals. Be careful to use parentheses to ensure that the rules for order of operations are maintained. In particular, sums and differences in numerators and denominators of fractions must be enclosed in parentheses. Study the following example carefully.

Example 5 Using a Calculator to Evaluate Radical Expressions

Use a TI-84 Plus graphing calculator to evaluate each expression. Round answers to the nearest ten-thousandth.

a. $3 + 2\sqrt{5}$

b. $(\sqrt{2} + 5)(\sqrt{2} - 5)$

Solution

a. The display should appear as follows.

Thus, $3 + 2\sqrt{5} = 7.4721359\dots \approx 7.4721$.

Rounded to the nearest ten-thousandth

b. The display should appear as follows.

Thus, $(\sqrt{2} + 5)(\sqrt{2} - 5) = -23$.

Note: When entering $\sqrt{2}$ on a calculator, the right parenthesis after the 2 must be included. Otherwise, the calculator will interpret the expression as $\sqrt{(2+5)}$ (or $\sqrt{7}$) which is not intended.

5. Use a TI-84 Plus graphing calculator to evaluate each expression. Round answers to the nearest ten-thousandth.

a. $4 + 5\sqrt{2}$

b. $(\sqrt{8} - 1)(\sqrt{8} + 1)$

Now work margin exercise 5.

Completion Example Answers

4. a. $6\sqrt{3} \cdot \sqrt{3} + 6\sqrt{3} \cdot 2\sqrt{7} = 18 + 12\sqrt{21}$ b. $\sqrt{x} \cdot \sqrt{x} + \sqrt{x} \cdot (-4) + 8 \cdot \sqrt{x} + 8 \cdot (-4) = x + 4\sqrt{x} - 32$

Margin exercise answers:

1. a. $\sqrt{66}$ b. $5\sqrt{7}$ c. $5y\sqrt{3}$ 2. a. $7 + 7\sqrt{3}$ b. $27 - 17\sqrt{5}$ c. $7a - 9$ 3. a. $4\sqrt{30} - 20$

b. $s + 2\sqrt{s} - 63$ 4. a. $\frac{\sqrt{3}}{5}$ b. $7\sqrt{4x+6}$ c. $7\sqrt{4x+6}$ 5. a. 11.0711 b. 7

10.5 Exercises

Concept Check

Fill-in-the-Blank. Complete each sentence using information found in this section.

- To find the product of radicals, we proceed just as in multiplying polynomials and use the _____ property.

2. To find the product of two binomials that contain radical terms, you can use the _____ method.
3. When translating English phrases into radical expressions, a/an _____ can indicate a change in operation.

True/False. Determine whether each statement is true or false. If a statement is false, explain how it can be changed so the statement will be true. (**Note:** There may be more than one acceptable change.)

4. The multiplication property of radicals says that $\sqrt{a} \cdot \sqrt{b} = \sqrt{ab}$ for all values of a and b .
5. The radicals do not need to be like radicals when multiplying radical expressions.
6. The keywords *product* and *triple* refer to multiplication.

Practice

Multiply the following radical expressions and then simplify the results. Assume that all variables represent positive real numbers. See Examples 1, 2, and 3.

1. $\sqrt{2}(3 - 4\sqrt{2})$
2. $2\sqrt{7}(\sqrt{7} + 3\sqrt{2})$
3. $3\sqrt{18} \cdot \sqrt{2}$
4. $2\sqrt{10} \cdot \sqrt{5}$
5. $-2\sqrt{6} \cdot \sqrt{8}$
6. $2\sqrt{15} \cdot 5\sqrt{6}$
7. $\sqrt{3}(\sqrt{2} + 2\sqrt{12})$
8. $\sqrt{2}(\sqrt{3} - \sqrt{6})$
9. $\sqrt{y}(\sqrt{x} + 2\sqrt{y})$
10. $\sqrt{x}(\sqrt{x} - 3\sqrt{y})$
11. $(3 + \sqrt{2})(5 - \sqrt{2})$
12. $(\sqrt{6} + 2)(\sqrt{6} - 2)$
13. $(\sqrt{3x} - 8)(\sqrt{3x} - 1)$
14. $(6 + \sqrt{2x})(4 + \sqrt{2x})$
15. $(2\sqrt{7} + 4)(\sqrt{7} - 3)$
16. $(5\sqrt{3} - 2)(2\sqrt{3} - 7)$
17. $(\sqrt{5} + 2\sqrt{2})^2$
18. $(2\sqrt{5} + 3\sqrt{2})^2$
19. $(\sqrt{2} + \sqrt{3})(\sqrt{5} - \sqrt{3})$
20. $(\sqrt{6} + \sqrt{5})(\sqrt{6} - \sqrt{2})$
21. $(\sqrt{x} + \sqrt{6})(\sqrt{x} - 3\sqrt{6})$
22. $(\sqrt{11} + \sqrt{3})(\sqrt{11} - 2\sqrt{3})$
23. $(3\sqrt{7} + \sqrt{5})(3\sqrt{7} - \sqrt{5})$
24. $(7\sqrt{x} + \sqrt{2})(7\sqrt{x} - \sqrt{2})$
25. $(\sqrt{x} + 5\sqrt{y})^2$
26. $(3\sqrt{x} + \sqrt{y})^2$
27. $(\sqrt{x+3} - 5)^2$
28. $(\sqrt{x+2} + 3)^2$
29. $(4 - \sqrt{2x+3})^2$
30. $(6 - \sqrt{4x+1})^2$

Translate the given phrase into an algebraic expression. Do not simplify. See Example 4.

31. A radicand of five with an index of two
32. The cube root of twelve
33. Four times the square root of ten x
34. The square root of five, divided by twelve x
35. The cube root of six y , plus seven y
36. The difference between eight x and the square root of eight x
37. The sum of fifteen and four times the square root of x
38. The product of two and the cube root of six y , plus eleven y
39. The cube root of four minus eight b
40. The cube root of x , divided by x minus three
41. The quotient of the square root of three and a , minus seven
42. Seven times the square root of y , divided by one minus y

 Use a graphing calculator to evaluate each expression. Round your answers to the nearest ten-thousandth, if necessary. See Example 5.

- | | |
|---------------------------------|--|
| 43. $13 - \sqrt{75}$ | 47. $(\sqrt{7} + 8)(\sqrt{7} - 8)$ |
| 44. $5 - \sqrt{67}$ | 48. $(\sqrt{8} - \sqrt{5})(\sqrt{8} + \sqrt{5})$ |
| 45. $\sqrt{900} + \sqrt{2.56}$ | 49. $(2\sqrt{3} + 5\sqrt{2})(\sqrt{10} - 3\sqrt{5})$ |
| 46. $\sqrt{1600} - \sqrt{1.69}$ | 50. $(6\sqrt{5} + 5\sqrt{7})(3\sqrt{2} - \sqrt{6})$ |

Applications

Solve.

51. The city planning committee is looking for places to build a community garden.

One lot up for consideration has a length of $\frac{8 + 2\sqrt{b}}{a}$ and a width of $\frac{6 + 5\sqrt{b}}{a}$.

If $a = 3$ yards and $b = 7$ yards, what is the area of this lot? Leave your answer in simplified radical form.

52. The owner of an apple orchard has a field of new trees that are growing and producing more apples each year. He wants to determine the average growth rate, or percentage increase, in the amount of apples produced by these trees over time. The amount of growth varies each year, so he decides to find the geometric mean, or average. The formula $g = \sqrt{a} \cdot \sqrt{b}$ is used to find the geometric mean of two numbers.
- a. Over two years, the growth rate was 180% and 120%. Find the average growth rate for these two years. Leave your answer in simplified radical form.
 - b. Over two years, the growth rate was $8x^3\%$ and $9x^5\%$. Find the average growth rate for these two years. Leave your answer in simplified radical form.

10.6 Exercises

Concept Check

Fill-in-the-Blank. Complete each sentence using information found in this section.

- The objective in simplifying a rational fraction is to find an equivalent fraction that has no radicals in the _____.
- To rewrite a fraction without irrational numbers in the denominator is to _____ the denominator.
- Calculations of sums and differences are much easier if the denominators are _____ expressions.
- The product of the conjugates $a + b$ and $a - b$ is the difference of two _____.
- To rationalize a denominator containing a sum or difference that involves a square root, multiply both the numerator and the denominator by the _____ of the denominator.
- The conjugate of _____ is $6 + \sqrt{x}$.

True/False. Determine whether each statement is true or false. If a statement is false, explain how it can be changed so the statement will be true. (**Note:** There may be more than one acceptable change.)

- The conjugate of $y - \sqrt{5}$ is $y + \sqrt{5}$.
- To rationalize the denominator, multiply only the denominator by an expression that will result in a denominator with no radicals.
- To rationalize a fraction whose denominator is $\sqrt[3]{a}$, you would need to multiply the numerator and the denominator by $\sqrt[3]{a}$.
- The fraction $\frac{\sqrt{2}}{3}$ is in simplest form.

Practice

Rationalize the denominator and simplify, if possible. Assume that all variables represent positive real numbers.

- | | | |
|---------------------------|---------------------------------|------------------------------------|
| 1. $\frac{5}{\sqrt{2}}$ | 5. $\frac{6}{\sqrt{3}}$ | 9. $\frac{\sqrt{27x}}{\sqrt{3x}}$ |
| 2. $\frac{7}{\sqrt{5}}$ | 6. $\frac{8}{\sqrt{2}}$ | 10. $\frac{\sqrt{45y}}{\sqrt{5y}}$ |
| 3. $\frac{-3}{\sqrt{7}}$ | 7. $\frac{\sqrt{18}}{\sqrt{2}}$ | 11. $\frac{\sqrt{ab}}{\sqrt{9ab}}$ |
| 4. $\frac{-10}{\sqrt{2}}$ | 8. $\frac{\sqrt{25}}{\sqrt{3}}$ | 12. $\frac{\sqrt{5}}{\sqrt{12}}$ |

- | | | | |
|--|---|-------------------------------------|--|
| 13. $\frac{\sqrt{4}}{\sqrt{3}}$ | 29. $-\sqrt{\frac{25}{x^3}}$ | 46. $\frac{-11}{\sqrt{3}-4}$ | 63. $\frac{8}{2\sqrt{x+3}}$ |
| 14. $\sqrt{\frac{3}{8}}$ | 30. $\frac{\sqrt{8x}}{\sqrt{5y^2}}$ | 47. $\frac{1}{\sqrt{5}-3}$ | 64. $\frac{3\sqrt{x}}{\sqrt{2x-5}}$ |
| 15. $\sqrt{\frac{9}{2}}$ | 31. $\frac{\sqrt{4x}}{\sqrt{3y^2}}$ | 48. $\frac{7}{3-2\sqrt{2}}$ | 65. $\frac{\sqrt{4y}}{\sqrt{5y}-\sqrt{3}}$ |
| 16. $\sqrt{\frac{3}{5}}$ | 32. $\frac{\sqrt{16y^2}}{\sqrt{2y^3}}$ | 49. $\frac{-6}{5-3\sqrt{2}}$ | 66. $\frac{\sqrt{3x}}{\sqrt{2+\sqrt{3x}}}$ |
| 17. $\sqrt{\frac{1}{x}}$ | 33. $\frac{\sqrt{24b}}{\sqrt{6b^2}}$ | 50. $\frac{11}{2\sqrt{3}+1}$ | 67. $\frac{3}{\sqrt{x}-\sqrt{y}}$ |
| 18. $\sqrt{\frac{x}{y}}$ | 34. $\sqrt[3]{\frac{2y^3}{27x^2}}$ | 51. $\frac{-\sqrt{3}}{\sqrt{2}+5}$ | 68. $\frac{4}{2\sqrt{x}+\sqrt{y}}$ |
| 19. $\sqrt{\frac{2x}{y}}$ | 35. $\sqrt[3]{\frac{7x}{2y^4}}$ | 52. $\frac{\sqrt{2}}{\sqrt{7}+4}$ | 69. $\frac{x}{\sqrt{x+2\sqrt{y}}}$ |
| 20. $\sqrt{\frac{x}{4y}}$ | 36. $\frac{\sqrt[3]{6a^4}}{\sqrt[3]{25a^2b^4}}$ | 53. $\frac{7}{1-3\sqrt{5}}$ | 70. $\frac{y}{\sqrt{x}-\sqrt{3y}}$ |
| 21. $\frac{2}{\sqrt{2y}}$ | 37. $\frac{\sqrt[3]{x^5}}{\sqrt[3]{9xy}}$ | 54. $\frac{-3\sqrt{3}}{6+\sqrt{3}}$ | 71. $\frac{\sqrt{3}+1}{\sqrt{3}-2}$ |
| 22. $\frac{-10}{3\sqrt{5}}$ | 38. $\frac{\sqrt[3]{24x}}{\sqrt[3]{9}}$ | 55. $\frac{1}{\sqrt{3}-\sqrt{5}}$ | 72. $\frac{\sqrt{2}+4}{5-\sqrt{2}}$ |
| 23. $\frac{21}{5\sqrt{7}}$ | 39. $\sqrt[3]{\frac{11}{4}}$ | 56. $\frac{-4}{\sqrt{7}-\sqrt{3}}$ | 73. $\frac{\sqrt{5}-2}{\sqrt{5}+3}$ |
| 24. $\frac{x}{5\sqrt{x}}$ | 40. $\sqrt[3]{\frac{3x^3}{8y^2}}$ | 57. $\frac{-5}{\sqrt{2}+\sqrt{3}}$ | 74. $\frac{1+\sqrt{3}}{3-\sqrt{3}}$ |
| 25. $\frac{-2y}{5\sqrt{2y}}$ | 41. $\frac{\sqrt[3]{5a}}{\sqrt[3]{3b^4}}$ | 58. $\frac{7}{\sqrt{2}+\sqrt{5}}$ | 75. $\frac{\sqrt{x}+1}{\sqrt{x}-1}$ |
| 26. $\frac{\sqrt[3]{35}}{\sqrt[3]{4}}$ | 42. $\sqrt[3]{\frac{7x^4}{16x^2y^4}}$ | 59. $\frac{4}{\sqrt{x}+1}$ | 76. $\frac{\sqrt{x}-4}{\sqrt{x}+3}$ |
| 27. $\frac{\sqrt[3]{10}}{\sqrt[3]{9}}$ | 43. $\frac{\sqrt[3]{a^5}}{\sqrt[3]{4ab}}$ | 60. $\frac{-7}{\sqrt{x}-3}$ | 77. $\frac{\sqrt{x}+2}{\sqrt{3x}+y}$ |
| 28. $-\sqrt{\frac{2}{3y}}$ | 44. $\frac{3}{1+\sqrt{2}}$ | 61. $\frac{5}{6+\sqrt{y}}$ | 78. $\frac{3-\sqrt{x}}{2\sqrt{x}+y}$ |
| | 45. $\frac{2}{\sqrt{6}-2}$ | 62. $\frac{x}{\sqrt{x}+2}$ | |



Identify the error(s) made in the following attempt to rationalize a denominator.

$$\begin{aligned}
 79. \quad \frac{y}{\sqrt{3+y}} &= \frac{y}{\sqrt{3+y}} \cdot \frac{\sqrt{3+y}}{\sqrt{3+y}} \\
 &= \frac{y(\sqrt{3+y})}{3+y^2} \\
 &= \frac{y\sqrt{3+y^2}}{3+y^2}
 \end{aligned}$$

Applications

Solve.

80. Officers often need to recreate events that happen during accidents while they investigate, especially determining the initial speed of a car at the time of an accident. One way to do this is to use the formula $\frac{s}{\sqrt{l}} = k$, where s is the initial speed of the vehicle in mph, l is the length of the skid marks left in feet, and k is a constant that depends on the driving conditions at the time of the accident.
- Rationalize the denominator of the formula.
 - A driver claims that he was driving the speed limit, 55 mph, at the time of an accident. The skid marks on the road measured 176 feet. Officers estimate that the driving condition constant k based on the conditions at the time of the accident is $\sqrt{24}$. Based on the formula, is the driver's claim correct? If not, what was the driver's initial speed before the accident?
81. The radius of a cylinder can be expressed in terms of its volume and its height by $r = \sqrt{\frac{V}{\pi h}}$. Rationalize the denominator of this formula.
82. A company that sells computers learns that their income can be represented by the equation $I = \frac{6500p}{\sqrt{p-10}}$ dollars when they sell their computers for p dollars. Rationalize the denominator of this equation.
83. An intern at NASA needs to construct a cylinder to be used as a fuel cell for a scale model of a rocket. Her instructions are to make a fuel cell with a volume of $200\pi \text{ cm}^3$. To find the radius of the fuel cell for a certain height h and volume V , she uses the equation $r = \sqrt{\frac{V}{h\pi}}$. Keep all answers in simplified radical form.
- Find the radius of the fuel cell if the height is 12 cm.
 - Find the radius of the fuel cell if the height is 15 cm.
 - Find the radius of the fuel cell if the height is 24 cm.

84.  The formula $r = \sqrt{\frac{A}{P}} - 1$ is used to determine the interest rate r of on an investment of initial value P that has a value of A after two years.
- Rationalize the denominator of the fraction in the formula.
 - Find the interest rate on an investment with initial value \$1000 that has a value of \$1102.50 after 2 years.
85.  A client tells his financial consultant that he has \$6000 to invest and would like to earn \$615 on his investment after 2 years. The client needs to know what the average interest rate of the investment will need to be to meet his expectations. The financial consultant can use the formula $A = P(r+1)^2$ to find the future amount A of an investment with a starting principle P and interest rate r after 2 years.
- Solve the equation for r . Be sure to rationalize any denominators. (**Hint:** Divide both sides by P first and then take the square root of each side.)
 - Determine the interest rate that the \$6000 would need to be invested at to meet the client's expectations. Be sure to express the rate as a percent.

Writing & Thinking

86. In your own words, explain how to rationalize the denominator of a fraction containing the sum or difference of square roots in the denominator. Why does this work?

Margin Exercise Answers

1. $x = -8, 8$ 2. $y = -2$ 3. $x = \frac{1}{2}, -3$ 4. No solution 5. $x = \frac{3}{4}$ 6. $x = 2$ 7. $x = 9, 25$ 8. $x = 8$

10.7 Exercises

Concept Check

Fill-in-the-Blank. Complete each sentence using information found in this section.

- To solve equations with radicals, first _____ one of the radicals on one side of the equation.
- Next, raise both sides of the equation to the power corresponding to the _____ of the radical.
- Solve the equation after all _____ have been eliminated.
- When both sides of an equation are raised to a power, a/an _____ solution may be introduced.
- Once all possible solutions have been found for an equation, those solutions should be checked to eliminate any _____ solutions.

True/False. Determine whether each statement is true or false. If a statement is false, explain how it can be changed so the statement will be true. (**Note:** There may be more than one acceptable change.)

- All radical equations will have two solutions.
- If no true statements result when all possible solutions are checked, then there is no solution.
- When solving equations with radicals, you should only have to raise both sides of the equation to a power one time.
- A radical expression set equal to a negative value, such as $\sqrt{x+2} = -4$, has no real solution.

Practice

Solve the following equations. Be sure to check your answers in the original equation.

- | | |
|-----------------------|----------------------------|
| 1. $\sqrt{8x+1} = 5$ | 7. $\sqrt{5x-6} = 8$ |
| 2. $\sqrt{7x+1} = 6$ | 8. $\sqrt{2x-5} = -1$ |
| 3. $\sqrt{3x+4} = -5$ | 9. $\sqrt{5x+4} = 7$ |
| 4. $\sqrt{4x-3} = 7$ | 10. $\sqrt{3x-2} = 4$ |
| 5. $\sqrt{6-x} = 3$ | 11. $\sqrt{x-4} + 6 = 2$ |
| 6. $\sqrt{11-x} = 5$ | 12. $\sqrt{6x+4} + 2 = 10$ |

13. $\sqrt{4x+1}+4=9$
14. $\sqrt{2x-7}+5=3$
15. $\sqrt{x(x+3)}=2$
16. $\sqrt{x(x-5)}=6$
17. $\sqrt{x(2x+5)}=5$
18. $\sqrt{x(3x-14)}=7$
19. $\sqrt{x+6}=x+4$
20. $\sqrt{x+7}=2x-1$
21. $\sqrt{x-2}=x-2$
22. $\sqrt{x+3}=x+3$
23. $x-2=\sqrt{3x-6}$
24. $x+6=\sqrt{2x+12}$
25. $\sqrt{x^2-16}=3$
26. $\sqrt{x^2-25}=12$
27. $5+\sqrt{x+5}-2x=0$
28. $x-2-\sqrt{x+4}=0$
29. $2x=\sqrt{7x-3}+3$
30. $x-\sqrt{3x-8}=4$
31. $\sqrt{2x+5}=\sqrt{4x-1}$
32. $\sqrt{5x-1}=\sqrt{x+7}$
33. $\sqrt{3x+2}=\sqrt{9x-10}$
34. $\sqrt{2+x}=\sqrt{2x-7}$
35. $\sqrt{2x-1}=\sqrt{x+1}$
36. $\sqrt{3x+2}=\sqrt{x+4}$
37. $\sqrt{x+2}=\sqrt{2x-5}$
38. $\sqrt{2x-5}=\sqrt{3x-9}$
39. $\sqrt{4x-3}=\sqrt{2x+5}$
40. $\sqrt{4x-6}=\sqrt{3x-1}$
41. $\sqrt{3x+1}=1-\sqrt{x}$
42. $\sqrt{x}=\sqrt{x+16}-2$
43. $\sqrt{x+4}=\sqrt{x+11}-1$
44. $\sqrt{1-x}+2=\sqrt{13-x}$
45. $\sqrt{x+1}=\sqrt{x+6}+1$
46. $\sqrt{x+4}=\sqrt{x+20}-2$
47. $\sqrt{x+5}+\sqrt{x}=5$
48. $\sqrt{x}+\sqrt{x-3}=3$
49. $\sqrt{2x+3}=1+\sqrt{x+1}$
50. $\sqrt{5x-18}-4=\sqrt{5x+6}$
51. $\sqrt{3x+1}-\sqrt{x+4}=1$
52. $\sqrt{3x+4}-\sqrt{x+5}=1$
53. $\sqrt{5x-1}=4-\sqrt{x-1}$
54. $\sqrt{2x-5}-2=\sqrt{x-2}$
55. $\sqrt{2x-1}+\sqrt{x+3}=3$
56. $\sqrt{2x+3}-\sqrt{x+5}=1$
57. $\sqrt[3]{4+3x}=-2$
58. $\sqrt[3]{2+9x}=9$
59. $\sqrt[3]{5x+4}=4$
60. $\sqrt[3]{7x+1}=-5$



Applications

Solve.

61.  When money is invested in an account earning an annual interest rate of $r\%$, and the money is left in the account for two years, the interest rate, the principal (the initial amount invested), and the value accumulated after two years are related by the following formula.

$$(r+1)\sqrt{P} = \sqrt{A}$$

In this formula, r is the annual interest rate written as a decimal, A is the accumulated value, and P is the principal invested.

- a. Suppose you originally invested your money at an annual interest rate of 5%, and at the end of 2 years, your account contained \$2000. How much did you initially invest? Round your answer to the nearest cent.
- b. Solve the formula for the annual interest rate so that you will have a formula for the interest rate in terms of the principal invested and the accumulated value.
62.  You want to buy a used car for \$8000. You already have \$7840 saved up for the car. However, the person you are buying the car from has received several offers already. The current owner of the car says that he will hold the car for you for one week before taking another offer. At your after-school job, you make $\sqrt{1500x} + 10$ dollars when you work x hours. How many hours will you need to work in the next week in order to be able to buy the car? (Assume that all money from your after-school job can go straight to your car fund.) Round your answer to the nearest whole hour.
63.  The hang time of an athlete can be represented by

$$t = 2\sqrt{\frac{2h}{g}},$$

where t is the hang time of the athlete in seconds, h is the height of the jump in feet, and g is the acceleration due to gravity. (The gravity constant g can be estimated by using 32 ft/sec².)



- a. If Michael Jordan had a vertical jump of 48 inches, how long would he be in the air?
- b. A volleyball player has a hang time of 0.866 seconds. How high is this player's vertical leap? Round your answer to the nearest foot.
64.  A company claims their new line of dishware is indestructible, so product testers are dropping dinner plates from varying distances to determine the damage that happens on impact with the ground. The equation $v = \sqrt{19.8h}$ is used to calculate the velocity v of the dinner plate in meters per second when it is dropped from a certain height h in meters. Round all answers to the nearest hundredth.
- a. From what height was the dinner plate dropped if its velocity on impact was 10 m/s?
- b. From what height was the dinner plate dropped if its velocity on impact was 25 m/s?
- c. From what height was the dinner plate dropped if its velocity on impact was 50 m/s?

65.  Giovanna drops a stone from the highest point of a bridge into the river below. When Giovanna dropped the stone, her arm was stretched out 2 m above the bridge.

The equation $t = \frac{\sqrt{10(d+2)}}{7}$ is used to find the time t it takes for a stone to drop a distance of $d + 2$ meters. If it takes the stone 2.5 seconds to hit the water, what is the height of the bridge to the nearest hundredth?

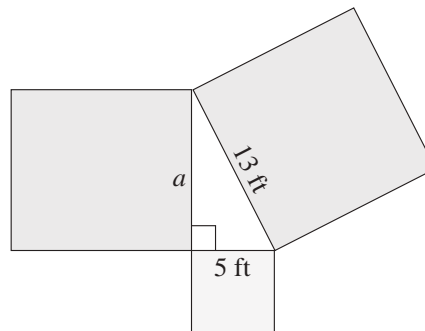
66. A landscaper is designing a pond in the shape of a right triangle that has a square flower patch along each edge. She knows two of the flower patches will have side lengths of 5 ft and 13 ft and that the remaining flower patch must have a side length a that satisfies the equation $13 = \sqrt{a^2 + 5^2}$. What is the side length of the remaining flower patch?



67.  A farmer fell asleep under a tree in his apple orchard while thinking about pie. While he was sleeping, a squirrel knocked an apple off of a branch of the tree. The function $f(d) = \sqrt{\frac{2d}{9.8}}$ can be used to find the amount of time in seconds that it takes for the apple to drop a certain distance d , where d is in meters. Round your answers to the nearest hundredth.
- If the apple was connected to a branch that was 2 meters above the farmer's head, how long would it take before the apple hit the top of the farmer's head?
 - If the squirrel knocked a second apple off of a branch that was 5 meters above the farmer's head, how long would it take before the apple hit the top of the farmer's head?
 - Suppose the second apple missed the farmer's head and landed on the ground instead. If the farmer's head was 0.8 meters above the ground, how long did it take for the apple to hit the ground?
68.  A person's Body Mass Index (BMI) is determined by the formula $B = \frac{703w}{h^2}$, where B is the BMI, w is the person's weight in pounds, and h is the person's height in inches. Having a BMI between 18.5 and 24.9 is considered optimal. A BMI between 25 and 29.9 is considered overweight and a BMI over 30 is considered obese. A BMI below 18.5 is considered underweight.
- Solve the BMI formula for the variable h .
 - How tall is a person who has a BMI of 20 and a weight of 120 pounds? Round to the nearest inch.
 - To be in the optimal BMI range with a weight of 200 pounds, what range in height should a person be? Round to the nearest inch. (**Hint:** Calculate the heights for the endpoints of the BMI range given.)
 - How tall is a person whose BMI is 30 and who weighs 150 pounds? Round to the nearest inch.

Margin Exercise Answer

1. a. 26 in. b. 9 cm 2. a. $d = 6$ b. $d = 10$ 3. a. $d = 5$ b. $d = \sqrt{29} \approx 5.39$ 4. $AB = \sqrt{58}$, $AC = 3\sqrt{5}$, and $BC = \sqrt{37}$. $\triangle ABC$ is not equilateral, it is scalene. 5. Triangle DEF is a right triangle since $(\sqrt{45})^2 + (\sqrt{80})^2 = (\sqrt{125})^2$.

10.8 Exercises

Concept Check

Fill-in-the-Blank. Complete each sentence using information found in this section.

1. A right triangle is a triangle in which one angle measures ___ degrees.
2. The longest side of a right triangle is called the _____.
3. In a/an _____ triangle, no two sides have equal lengths.

True/False. Determine whether each statement is true or false. If a statement is false, explain how it can be changed so the statement will be true. (**Note:** There may be more than one acceptable change.)

4. The Pythagorean Theorem is true for all triangles.
5. The distance d between two points may be negative.
6. An isosceles triangle has at least two sides that are equal in length.

Practice

Use the Pythagorean Theorem to determine whether each triangle is a right triangle.

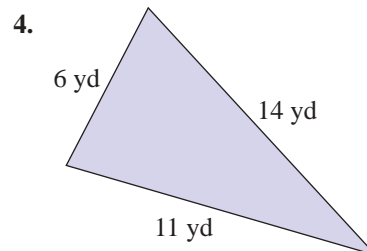
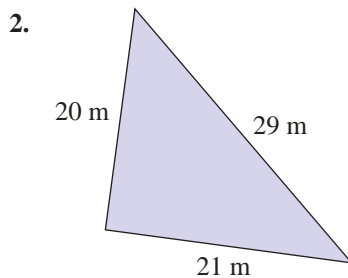
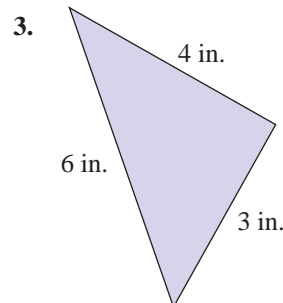
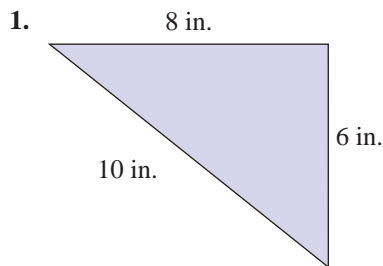

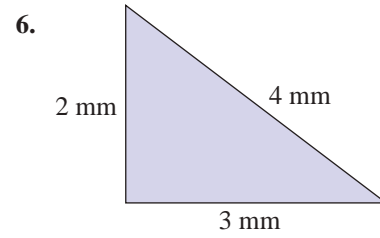
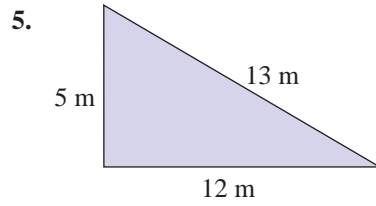

Find the hypotenuse for each right triangle accurate to the nearest hundredth. See Example 1.

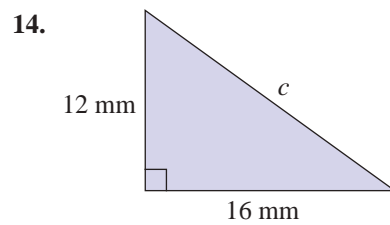
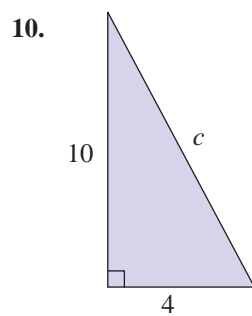
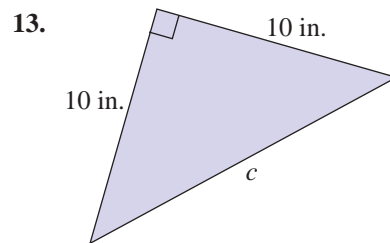
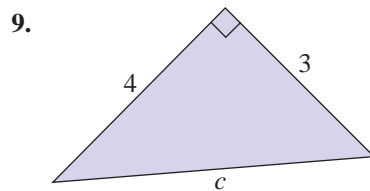
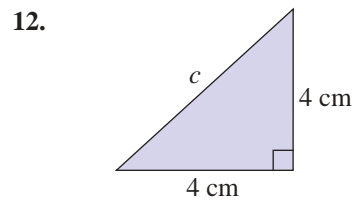
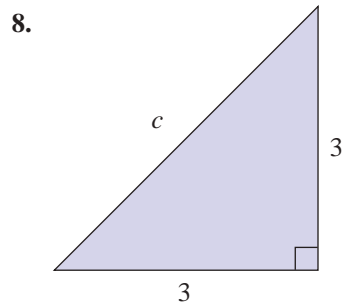
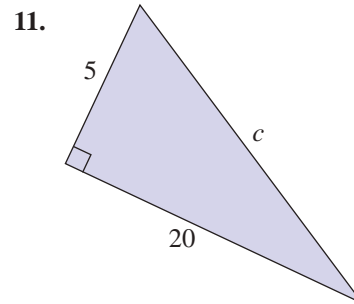
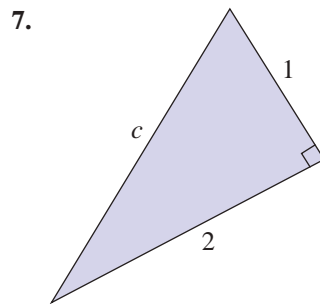

Find the distance between the two points given. See Examples 2 and 3.

15. $(-3, 6), (-3, 2)$

16. $(5, 7), (-3, 7)$

17. $(4, -3), (7, -3)$

18. $(-1, 2), (5, 2)$

19. $(3, 1), \left(\frac{-1}{2}, 1\right)$

20. $\left(\frac{4}{3}, 1\right), \left(\frac{4}{3}, \frac{-2}{3}\right)$

21. $(3, 1), (2, 0)$

22. $(4, 6), (5, -2)$

23. $(1, 5), (-1, 2)$

24. $(0, 0), (-3, 4)$

25. $(2, -7), (-3, 5)$

26. $(5, -3), (7, -3)$

27. $\left(\frac{3}{7}, \frac{4}{7}\right), (0, 0)$

28. $(-5, 2), (1, 1)$

29. $(4, 1), (7, 5)$

30. $(10, 7), (1, 7)$

31. $(-10, 3), (2, -2)$

32. $\left(\frac{7}{3}, 2\right), \left(\frac{-2}{3}, 1\right)$

33. $(-3, 2), (3, -6)$

34. $\left(\frac{3}{4}, 6\right), \left(\frac{3}{4}, -2\right)$

35. $(4, 0), (0, -3)$

36. $(0, -2), (4, -3)$

37. $\left(\frac{4}{5}, \frac{2}{7}\right), \left(\frac{-6}{5}, \frac{2}{7}\right)$

38. $(6, 8), (2, 5)$

39. Use the distance formula and the Pythagorean Theorem to determine whether the triangle with vertices at $A(1, -2)$, $B(7, 1)$ and $C(5, 5)$ is a right triangle.

40. Use the distance formula and the Pythagorean Theorem to determine whether the triangle with vertices at $A(-5, -1)$, $B(2, 1)$, and $C(-1, 6)$ is a right triangle.

41. Use the distance formula to determine whether the triangle with vertices $A(1, 1)$, $B(5, 9)$, and $C(9, 5)$ is an isosceles triangle.

42. Use the distance formula to determine whether the triangle with vertices $A(1, -4)$, $B(3, 2)$, and $C(9, 4)$ is an isosceles triangle.

43. Use the distance formula to determine whether the triangle with vertices $A(1, 0)$, $B(3, \sqrt{12})$, and $C(5, 0)$ is an equilateral triangle.

44. Use the distance formula to determine whether the triangle with vertices $A(0, 5)$, $B(0, -3)$, and $C(\sqrt{48}, 1)$ is an equilateral triangle.

Use the distance formula to find the perimeter of the triangle with the given vertices.

45. $A(-5, 0), B(3, 4), C(0, 0)$

47. $A(-2, 5), B(3, 1), C(2, -2)$

46. $A(-6, -1), B(-3, 3), C(6, 4)$

48. $A(-1, 3), B(2, 3), C(-2, -\sqrt{11}+3)$

Applications

Solve.

49. A square is said to be *inscribed* in a circle if each corner of the square lies on the circle. A furniture designer plans to create an end table with a 30-inch circular wooden tabletop inscribed with a marble square.
- Find the circumference and area of the tabletop. Use $\pi = 3.14$.
 - Find the perimeter and area of the marble square inscribed on the tabletop.

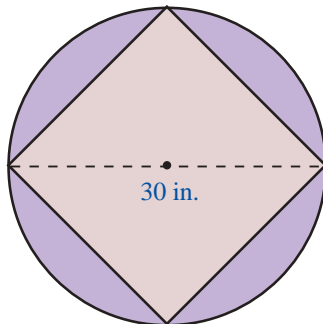

50. To create a square inside a square, a quilting pattern requires four triangular pieces like the one shaded in the figure shown here. If the square in the center measures 12 centimeters on a side, and the two legs of each triangle are of equal length, how long are the legs of each triangle, to the nearest tenth of a centimeter?

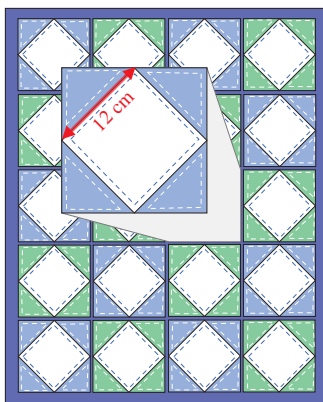

51. If an airplane passes directly over your head at an altitude of 1 mile, how far (to the nearest hundredth of a mile) is the airplane from your position after it has flown 2 miles farther at the same altitude?

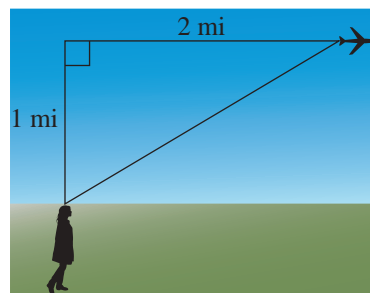

52. The GE Building in New York is 850 feet tall (70 stories). At a certain time of day, the building casts a shadow 100 feet long. Find the distance from the top of the building to the tip of the shadow (to the nearest tenth of a foot).

53. The base of a fire engine ladder is 30 feet from a building and reaches to a third floor window 50 feet above ground level. Find the length of the ladder to the nearest hundredth of a foot.

54. A forestay that helps support a ship's mast reaches from the top of the mast, which is 20 meters high, to a point on the deck 10 meters from the base of the mast. What is the length of the forestay (to the nearest tenth of a meter)?

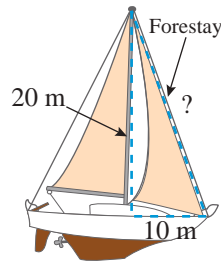

55. The Xerox Center building in Chicago is 500 feet tall. At a certain time of day, it casts a shadow that is 150 feet long. At that time of day, what is the distance (to the nearest tenth of a foot) from the tip of the shadow to the top of the Xerox building?
56. The shape of a baseball infield is a square with sides 90 feet long.

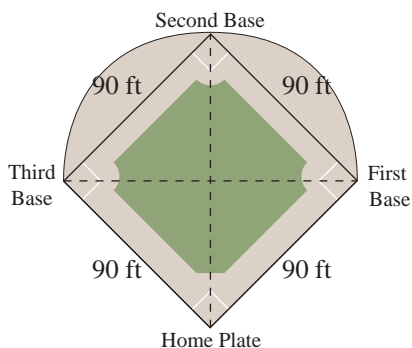

- Find the distance (to the nearest tenth of a foot) from home plate to second base.
- The diagonals of the square intersect halfway between home plate and second base. If the pitcher's mound is 60.5 feet from home plate, is the pitcher's mound closer to home plate or to second base?

57. A diagonal of a square is the line segment from one corner to an opposite corner of a square. A square has side length of 5 in.

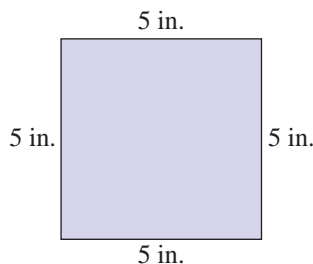

- Find the perimeter of the square.
 - Find the area of the square.
 - Find the length of a diagonal of the square.
58. Before painting a picture on canvas, an artist must stretch the canvas on a rectangular wooden frame. To be sure that the corners of the canvas are true right angles, the artist can measure the diagonals of the stretched canvas. What should be the diagonal measure, to the nearest tenth of an inch, of a canvas whose sides are 24 inches and 30 inches in length?
59. While installing windows in a new home, a builder measures the diagonals of rectangular window casements to verify that their corners are true right angles. What should be the diagonal measure, to the nearest tenth of an inch, of a window casement with dimensions 36 inches and 54 inches.

60. The shape of home plate in the game of baseball can be created by cutting off two triangular pieces at the corners of a square, as shown in the figure. If each of the triangular pieces has a hypotenuse of 12 inches and legs of equal length, what is the length of one side of the original square, to the nearest tenth of an inch?

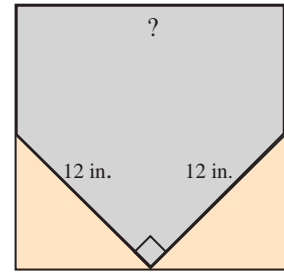

61. The city needs to replant an 18-foot tree. To ensure the tree does not fall over, three wires are to be attached to the tree 3 feet from the top. The wires will extend 8 feet from the base of the tree.
- How long will each wire be? Round to the nearest hundredth.
 - What will be the total length of the three wires?
62. A hiker hikes 9 kilometers north and then turns left and hikes 11 kilometers west. If she takes the shortest path, how long will she have to walk to get back? Assume the terrain is flat with no obstructions. Round the answer to the closest tenth.
63. A simple diamond-shaped kite is created from wooden dowel rods and nylon cloth. A diagram for the kite is shown.

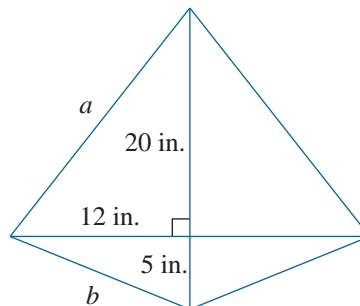

- Determine the length of side a . Write your answer in simplified radical form.
- Determine the length of side b . Write your answer in simplified radical form.
- Calculate the perimeter of the kite. Write your answer in simplified radical form.

Writing & Thinking

64. If three whole numbers satisfy the Pythagorean Theorem, these three numbers are called a Pythagorean triple. For example, 3, 4, and 5 are a Pythagorean triple because $3^2 + 4^2 = 5^2$ (or $9 + 16 = 25$). Another Pythagorean triple is 5, 12, and 13 because $5^2 + 12^2 = 13^2$ (or $25 + 144 = 169$). Complete the following table by finding a , b , and c , and telling which sets of these three numbers (if any) constitute a Pythagorean triple. The first one is done for you.

| m | n | $a = 2nm$ | $b = m^2 - n^2$ | $c = m^2 + n^2$ | Pythagorean Triple? |
|-----|-----|-----------|-----------------|-----------------|---------------------------|
| 5 | 1 | 10 | 24 | 26 | yes: $10^2 + 24^2 = 26^2$ |
| 7 | 1 | | | | |
| 3 | 2 | | | | |
| 7 | 2 | | | | |
| 5 | 3 | | | | |
| 11 | 3 | | | | |
| 13 | 7 | | | | |

Extension: Choose some of your own numbers for m and n . Are your results Pythagorean triples? (**Note:** m must be larger than n so $m^2 - n^2$ will be positive.)

Completion Example Answers5. 20 ; $\pm 2\sqrt{5}$; $-2 \pm 2\sqrt{5}$ **Margin Exercise Answers**1. $x = 2, 8$ 2. $x = 3$ 3. $x = -6 \pm 2\sqrt{3}$ 4. $x = \pm\sqrt{13}$ 5. $x = 4 \pm 2\sqrt{3}$ 6. No real solution 7. 10 feet 8. $\frac{5\sqrt{2}}{2}$ inches (≈ 3.54 inches)

11.1 Exercises

Concept Check

Fill-in-the-Blank. Complete each sentence using information found in this section.

- In a right triangle, the square of the length of the _____ is equal to the sum of the _____ of the lengths of the two legs.
- The two equations $x = \sqrt{c}$ or $x = -\sqrt{c}$ can be written as _____.
- When using the square root method, if the squared expression is set equal to a/an _____ number, then the solution will be nonreal.
- When using the square root method, you take the square root of _____ side(s).

True/False. Determine whether each statement is true or false. If a statement is false, explain how it can be changed so the statement will be true. (**Note:** There may be more than one acceptable change.)

- Using the square root method on an equation of the form $x^2 = c$, where c is a nonnegative number, will always result in two distinct solutions.
- Quadratic equations that are not easily solved using factoring might be solved by the square root method.

Practice

Solve the following quadratic equations by factoring. See Examples 1 and 2.

- | | |
|--------------------------|-------------------------------------|
| 1. $x^2 = 11x$ | 6. $5x^2 + 17x = -6$ |
| 2. $x^2 - 10x + 16 = 0$ | 7. $(x+3)(x-1) = 4x$ |
| 3. $x^2 = -15x - 36$ | 8. $(x-7)(x-2) = 6$ |
| 4. $2x^2 + 36x + 34 = 0$ | 9. $(2x-3)(2x+1) = 3x-6$ |
| 5. $9x^2 + 6x - 15 = 0$ | 10. $(x-2)(5x+4) = 3x^2 - 15x - 12$ |

Solve the following quadratic equations by using the square root method. Write each radical in simplest form. See Examples 3 through 6.

- | | |
|---------------------|------------------------------|
| 11. $x^2 = 121$ | 31. $5(x-3)^2 = 20$ |
| 12. $x^2 = 81$ | 32. $(x+8)^2 = -9$ |
| 13. $3x^2 = 108$ | 33. $(x+1)^2 = \frac{1}{4}$ |
| 14. $5x^2 = 245$ | 34. $(x-9)^2 = \frac{9}{25}$ |
| 15. $x^2 = 35$ | 35. $(x-2)^2 = \frac{1}{16}$ |
| 16. $x^2 = 42$ | 36. $(x-3)^2 = \frac{4}{9}$ |
| 17. $3x^2 - 75 = 0$ | 37. $(x+2)^2 = 7$ |
| 18. $x^2 + 81 = 0$ | 38. $(x+8)^2 = 75$ |
| 19. $x^2 - 62 = 0$ | 39. $(5x-2)^2 = 63$ |
| 20. $x^2 - 75 = 0$ | 40. $(4x-3)^2 = 125$ |
| 21. $x^2 - 45 = 0$ | 41. $(3x+4)^2 + 3 = 30$ |
| 22. $x^2 - 98 = 0$ | 42. $(2x+1)^2 + 12 = 60$ |
| 23. $3x^2 = 54$ | 43. $2(x-7)^2 = 24$ |
| 24. $5x^2 = 60$ | 44. $3(x+11)^2 = 60$ |
| 25. $9x^2 = 4$ | 45. $3(x-5)^2 - 5 = 25$ |
| 26. $4x^2 = 25$ | 46. $2(x-6)^2 - 11 = 25$ |
| 27. $(x-1)^2 = 4$ | 47. $3(x^2 - 15) - 7 = 20$ |
| 28. $(x+3)^2 = 9$ | 48. $-4(x^2 + 12) + 1 = 25$ |
| 29. $2(x+2)^2 = 50$ | |
| 30. $(x-5)^2 = 36$ | |

The lengths of two sides are given for each of the following right triangles. Determine the length of the missing side. See Examples 7 and 8.

49. $a = 9, b = 12, c = ?$

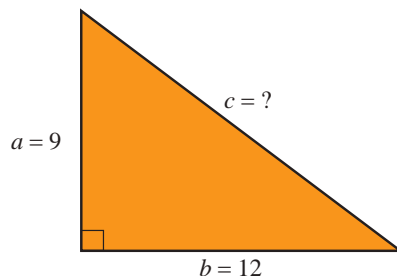

50. $a = 10, b = 24, c = ?$

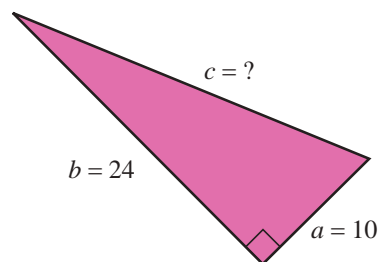

51. $a = 6, c = 12, b = ?$

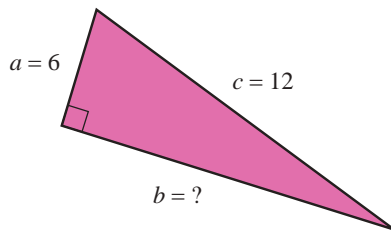

53. $a = 1, c = \sqrt{2}, b = ?$

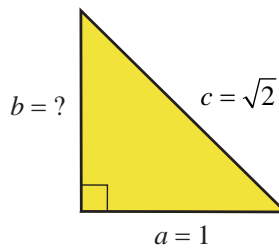

52. $b = 10, c = 30, a = ?$

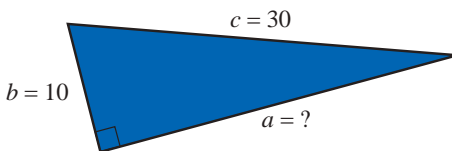

54. $b = 4, c = 4\sqrt{2}, a = ?$

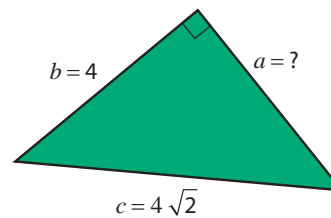

Use a calculator to solve the following quadratic equations. Round your answers to the nearest hundredth.

55. $x^2 = 647$

59. $6x^2 = 17.32$

56. $x^2 = 378$

60. $15x^2 = 229.63$

57. $19x^2 = 523$

61. $2.1x^2 = 35.82$

58. $14x^2 = 795$

62. $4.7x^2 = 118.34$

Use a calculator to find the two values of each expression accurate to the nearest ten-thousandth.

63. $2 \pm \sqrt{5}$

65. $\frac{2 \pm \sqrt{7}}{2}$





64. $-4 \pm \sqrt{89}$

66. $\frac{5 \pm \sqrt{13}}{10}$

Applications

Solve.

67. The hypotenuse of a right triangle is twice the length of one of the legs. The length of the other leg is $4\sqrt{3}$ feet. Find the length of the leg and the hypotenuse.
68. One leg of a right triangle is three times the length of the other. The length of the hypotenuse is 20 cm. Find the lengths of the legs.
69. The two legs of a right triangle are the same length. The hypotenuse is 6 cm long. Find the length of the legs.
70. The two legs of a right triangle are the same length. The hypotenuse is $4\sqrt{2}$ m long. Find the length of the legs.

71.  A 38-foot ladder is leaning against a building that is 34 feet high. The top of the ladder extends 3 feet beyond the point where it touches the building.
- How far is the base of the ladder from the base of the building? Write your answer as a decimal number rounded to the nearest tenth.
 - According to OSHA guidelines, the distance from the base of the ladder to the building should be $\frac{1}{4}$ the distance from the ground to the point of contact. Does the distance of the base of the ladder to the building meet the safety guidelines? Explain your answer.
72.  The top of a telephone pole is 40 feet above the ground and a guy wire is to be stretched from the top of the pole to a point on the ground 10 feet from the base of the pole. For proper installation, the wire needs to be 7 feet longer than the distance from the top of the pole to the point on the ground. How long should the wire be?
73.  The library is located “around the corner” from the bank. If the library is 100 yards from the street corner and the bank is 75 yards around the corner on another street, what is the distance between the library and the bank “as the crow flies?”
74. A ball is dropped from the top of a building that is known to be 144 feet high. The formula for finding the height of the ball at any time is $h = 144 - 16t^2$ where t is measured in seconds. How many seconds will it take for the ball to hit the ground?
75. A ball is dropped from the top of a building that is 784 feet high. The height of the ball above ground level is given by the polynomial function $h(t) = -16t^2 + 784$ where t is measured in seconds.
- How high is the ball after 3 seconds? 5 seconds?
 - How far has the ball traveled in 3 seconds? 5 seconds?
 - When will the ball hit the ground? Explain your reasoning in terms of factors.
76. A tennis ball is dropped from a building. The position of the ball after t seconds is given by the polynomial function $s(t) = -4.9t^2 + 490$, where s is the height in meters of the ball.
- Find $s(0)$ What does this value represent in the context of this problem?
 - How high is the tennis ball 2 seconds after it has been dropped?
 - How long before the tennis ball hits the ground?
77.  An oil spill from a ruptured pipeline is circular in shape and covers an area of about 8 square miles. About how many miles long (to the nearest tenth of a mile) is the diameter of the oil spill? (Use $\pi = 3.14$.)

78. A financial consultant is asked for advice about finances and savings plans. When a client invests money, they need to know which interest rate will meet their financial goals based on the amount invested. The financial consultant can use the formula $A = P(r + 1)^n$ to find the future amount A , after n years, of an investment with a starting principal P invested at an interest rate of r .
- A client has \$3000 to invest and would like to earn \$300 on his investment after 2 years. At what interest rate will the client need to invest his money? Round to the nearest hundredth of a percent.
 - Another client has \$5000 to invest and would like to earn \$750 on her investment after 2 years. At what interest rate will the client need to invest her money? Round to the nearest hundredth of a percent.

$$\begin{aligned}(x-3-\sqrt{5})(x-3+\sqrt{5}) &= 0 \\ [(x-3)-\sqrt{5}][(x-3)+\sqrt{5}] &= 0 \\ (x-3)^2 - (\sqrt{5})^2 &= 0 \\ x^2 - 6x + 9 - 5 &= 0 \\ x^2 - 6x + 4 &= 0\end{aligned}$$

Regroup the terms to make the multiplication easier.

This equation has two solutions:

$$x = 3 + \sqrt{5} \text{ and } x = 3 - \sqrt{5}$$

Now work margin exercise 9.

Completion Example Answers

$$\begin{aligned}6. \quad 2x^2 - 12x &= \underline{-2} \\ x^2 - 6 &= \underline{-1} \\ x^2 - 6x + \underline{9} &= \underline{-1} + \underline{9} \\ (x - \underline{3})^2 &= \underline{8} \\ x - \underline{3} &= \pm \underline{\sqrt{8}} \\ x &= \underline{3} \pm \underline{2\sqrt{2}}\end{aligned}$$

Margin Exercise Answers

$$\begin{aligned}1. \text{ a. } y^2 - 14y + 49 &= (y-7)^2 \quad \text{b. } x^2 + 9x + \frac{81}{4} = \left(x + \frac{9}{2}\right)^2 \quad 2. x = 5 \pm 2\sqrt{14} \quad 3. x = -1 \pm \sqrt{7} \\ 4. x = \frac{-1 \pm \sqrt{19}}{2} \quad 5. x = -2 \pm \sqrt{7} \quad 6. x = 1 \pm \sqrt{6} \quad 7. y^2 - 32 = 0 \quad 8. x^2 - 4x - 14 = 0 \\ 9. x^2 - 2x - 4 = 0\end{aligned}$$

11.2 Exercises

Concept Check

Fill-in-the-Blank. Complete each sentence using information found in this section.

- Completing the square is the process of adding terms to binomials so that the result will be a perfect square _____.
- To solve a quadratic equation by completing the square, arrange terms with _____ on one side of the equation and _____ on the other.
- When solving by completing the square, the quadratic equation should have a leading coefficient of _____.
- After finding the coefficient that completes the square of the polynomial, _____ this constant to both sides of the equation.
- When completing the square, the constant term is the _____ of $\frac{1}{2}$ of the coefficient of x .

True/False. Determine whether each statement is true or false. If a statement is false, explain how it can be changed so the statement will be true. (**Note:** There may be more than one acceptable change.)

6. To get a leading coefficient of 1, multiply both sides of the equation by the reciprocal of the leading coefficient.
7. When solving a quadratic equation, there is either no solution or two solutions.
8. The last step of solving a quadratic equation by completing the square is to use the square root property.

Practice

Add the correct constant to complete the square; then factor the trinomial as indicated. See Example 1.

- | | |
|--|--|
| 1. $x^2 - 12x + \underline{\hspace{1cm}} = (\underline{\hspace{1cm}})^2$ | 8. $x^2 + \frac{1}{2}x + \underline{\hspace{1cm}} = (\underline{\hspace{1cm}})^2$ |
| 2. $y^2 + 14y + \underline{\hspace{1cm}} = (\underline{\hspace{1cm}})^2$ | 9. $x^2 + \frac{1}{3}x + \underline{\hspace{1cm}} = (\underline{\hspace{1cm}})^2$ |
| 3. $x^2 + 6x + \underline{\hspace{1cm}} = (\underline{\hspace{1cm}})^2$ | 10. $y^2 + \frac{3}{4}y + \underline{\hspace{1cm}} = (\underline{\hspace{1cm}})^2$ |
| 4. $x^2 + 8x + \underline{\hspace{1cm}} = (\underline{\hspace{1cm}})^2$ | 11. $2x^2 + 4x + \underline{\hspace{1cm}} = 2(\underline{\hspace{1cm}})^2$ |
| 5. $x^2 - 5x + \underline{\hspace{1cm}} = (\underline{\hspace{1cm}})^2$ | 12. $3x^2 + 18x + \underline{\hspace{1cm}} = 3(\underline{\hspace{1cm}})^2$ |
| 6. $x^2 + 7x + \underline{\hspace{1cm}} = (\underline{\hspace{1cm}})^2$ | |
| 7. $y^2 + y + \underline{\hspace{1cm}} = (\underline{\hspace{1cm}})^2$ | |

Solve the quadratic equations by completing the square. See Examples 2 through 6.

- | | |
|--------------------------|-------------------------|
| 13. $x^2 + 4x - 5 = 0$ | 25. $x^2 - 6x + 5 = 0$ |
| 14. $x^2 + 6x - 7 = 0$ | 26. $x^2 - 4x + 3 = 0$ |
| 15. $y^2 + 2y = 5$ | 27. $x^2 + 11 = 12x$ |
| 16. $x^2 + 3 = 8x$ | 28. $x^2 = 6 - x$ |
| 17. $x^2 + 3 = 10x$ | 29. $y^2 = 10y - 4$ |
| 18. $z^2 + 4z = 2$ | 30. $x^2 = 3 - 4x$ |
| 19. $x^2 - 4x - 45 = 0$ | 31. $z^2 + 3z - 5 = 0$ |
| 20. $x^2 - 10x + 21 = 0$ | 32. $x^2 - 5x + 5 = 0$ |
| 21. $x^2 - 3x - 40 = 0$ | 33. $x^2 + x - 1 = 0$ |
| 22. $x^2 + x - 42 = 0$ | 34. $y^2 + 3y + 1 = 0$ |
| 23. $3x^2 + x - 4 = 0$ | 35. $x^2 + 5x + 2 = 0$ |
| 24. $2x^2 + x - 6 = 0$ | 36. $4x^2 + 7x + 2 = 0$ |

37. $3x^2 - 10x + 5 = 0$

38. $3y^2 + 5y - 3 = 0$

39. $3x^2 + 6x - 12 = 0$

40. $4x^2 + 8x - 8 = 0$

41. $-4x - 5 = -8x^2$

42. $2x - 2 = -6x^2$

43. $5x^2 + 15x - 25 = 0$

44. $4x^2 + 28x + 32 = 0$

45. $3y^2 = 4 - y$

46. $2x^2 + 4 = -9x$

47. $2x^2 - 8x + 4 = 0$

48. $3x^2 - 18x + 12 = 0$

Write a quadratic equation with integer coefficients that has the given roots.
See Examples 7 through 9.

49. $x = \sqrt{7}, x = -\sqrt{7}$

50. $x = \sqrt{6}, x = -\sqrt{6}$

51. $x = 1 + \sqrt{3}, x = 1 - \sqrt{3}$

52. $z = 3 + \sqrt{2}, z = 3 - \sqrt{2}$

53. $y = -2 + 2\sqrt{5}, y = -2 - 2\sqrt{5}$

54. $x = 1 + 2\sqrt{3}, x = 1 - 2\sqrt{3}$

Applications

Solve.

55. A local frame shop determines that the revenue function for their custom framing service is $R(p) = 360p - 4p^2$, where p is the base price in dollars for each custom framing job.

- Set the function equal to 0 and solve for p using the method of completing the square.
- What do the solutions from part a. mean?

56. The height of a golf ball that is hit from the ground at a speed of 128 feet per second can be modeled with the expression $h(t) = -16t^2 + 128t$, where t is the time in seconds after the ball is hit.

- Set the function equal to 0 and solve for t using the method of completing the square.
- What do the solutions from part a. mean?

Writing & Thinking

57. Explain, in your own words, the steps involved in the process of solving a quadratic equation by completing the square.

11.3 Exercises

Concept Check

Fill-in-the-Blank. Complete each sentence using information found in this section.

- The general form of a quadratic equation is _____.
- In the quadratic formula, the expression $b^2 - 4ac$ is called the _____.
- The quadratic formula is $x =$ _____.
- When using the quadratic formula, the value of a cannot be _____.
- To develop the quadratic formula, the general quadratic equation is solved by _____ the square.
- In the case where the discriminant is zero, there is one real solution, also called a/an _____ root.

True/False. Determine whether each statement is true or false. If a statement is false, explain how it can be changed so the statement will be true. (**Note:** There may be more than one acceptable change.)

- If the discriminant is a perfect square, the quadratic equation is factorable.
- When using the quadratic formula, if the discriminant is greater than zero, there are infinite solutions.
- If the discriminant is less than zero, there is no real solution.

Practice

Find the discriminant and determine the nature of the solutions of each quadratic equation. See Examples 7 through 9.

- | | |
|------------------------|-------------------------|
| 1. $x^2 + 6x - 8 = 0$ | 7. $5x^2 + 8x + 3 = 0$ |
| 2. $x^2 + 3x + 1 = 0$ | 8. $4x^2 + 12x + 9 = 0$ |
| 3. $x^2 - 8x + 16 = 0$ | 9. $100x^2 - 49 = 0$ |
| 4. $x^2 + 3x + 5 = 0$ | 10. $9x^2 + 121 = 0$ |
| 5. $4x^2 + 2x + 3 = 0$ | 11. $3x^2 + x + 1 = 0$ |
| 6. $3x^2 - x + 2 = 0$ | 12. $5x^2 - 3x - 2 = 0$ |

Solve each of the quadratic equations using the quadratic formula or state that the equation has no real solution. See Examples 1 through 5.

- | | |
|---------------------------|-------------------------|
| 13. $x^2 + 4x - 4 = 0$ | 19. $2x^2 + 5x - 3 = 0$ |
| 14. $x^2 - 6x - 1 = 0$ | 20. $3x^2 - 7x + 4 = 0$ |
| 15. $9x^2 + 12x + 4 = 0$ | 21. $4x^2 + 6x + 1 = 0$ |
| 16. $4x^2 - 20x + 25 = 0$ | 22. $2x^2 - 3x - 1 = 0$ |
| 17. $x^2 - 2x - 4 = 0$ | 23. $4x^2 + 6x + 3 = 0$ |
| 18. $x^2 - 2x + 3 = 0$ | 24. $x^2 - 5x + 1 = 0$ |

Solve each of the quadratic equations or state that the equation has no real solution. Use any of the techniques discussed for solving quadratic equations: factoring, completing the square, or using the quadratic formula.

25. $x^2 + 3x - 5 = 0$

26. $x^2 - 7x - 3 = 0$

27. $x^2 + 4x + 3 = 0$

28. $x^2 + 14x + 49 = 0$

29. $x^2 + 8 = 0$

30. $x^2 - 7 = 0$

31. $x^2 - 5x + 2 = 0$

32. $3x^2 + 2x - 2 = 0$

33. $16x^2 + 8x = -1$

34. $6x^2 = 5x + 1$

35. $3x^2 - 4 = 0$

36. $4x^2 + 9 = 0$

37. $9x^2 - 12x + 4 = 0$

38. $9x^2 - 6x + 1 = 0$

39. $2x^2 = -8x - 9$

40. $3x^2 = 6x + 4$

41. $5x^2 - 5 = 6x$

42. $4x^2 - 5x = -3$

43. $6x^2 + 2x = 20$

44. $10x^2 + 30 = -35x$

45. $3x^2 = 18x - 33$

46. $2x^2 = 16x + 36$

47. $x^2 + 4x = x - 2x^2$

48. $3x^2 + 4x = 0$

49. $x^3 - 9x^2 + 4x = 0$

50. $x^3 - 8x^2 = 3x^2 + 3x$

51. $x^3 + 3x^2 + x = 0$

52. $4x^3 + 10x^2 - 3x = 0$

53. $(2x+1)(x+3) = 2x+6$

54. $(x+5)(x-1) = -3$

55. $(3x-1)(x-2) = x+5$

56. $(x+4)(x-2) = -4$

First multiply each side of the equation by the LCD to get integer coefficients and then solve the resulting equation. See Example 3.

57. $3x^2 - 4x + \frac{1}{3} = 0$

58. $\frac{3}{4}x^2 - 2x + \frac{1}{8} = 0$

59. $2x^2 - \frac{2}{3}x + \frac{2}{9} = 0$

60. $2x^2 + 3x - \frac{5}{4} = 0$

61. $\frac{1}{2}x^2 - x - \frac{3}{4} = 0$

62. $\frac{2}{3}x^2 - \frac{1}{3}x + \frac{1}{2} = 0$

63. $\frac{1}{4}x^2 + \frac{7}{8}x + \frac{1}{2} = 0$

64. $\frac{5}{12}x^2 - \frac{1}{2}x - \frac{1}{4} = 0$

65. Determine the value(s) for c such that $x^2 - 8x + c = 0$ will have two real solutions.

66. Determine the value(s) for c such that $x^2 + 5x + c = 0$ will have two real solutions.

67. Determine the value(s) for c such that $x^2 + 9x + c = 0$ will have one real solution.

68. Determine the value(s) for c such that $x^2 - 7x + c = 0$ will have one real solution.

69. Determine the value(s) for a such that $ax^2 - 6x + 3 = 0$ will have no real solution.



70. Determine the value(s) for a such that $ax^2 + 4x - 2 = 0$ will have no real solution.
71. Determine the value(s) for a such that $ax^2 + x - 9 = 0$ will have two real solutions.
72. Determine the value(s) for a such that $ax^2 + 6x + 3 = 0$ will have two real solutions.
73. Determine the value(s) for a such that $ax^2 + 7x + 12 = 0$ will have one real solution.
74. Determine the value(s) for a such that $ax^2 - 2x + 8 = 0$ will have one real solution.
75. Determine the value(s) for c such that $3x^2 + 4x + c = 0$ will have no real solution.
76. Determine the value(s) for c such that $2x^2 + 3x + c = 0$ will have no real solution.

 Solve the quadratic equations using the quadratic formula and your calculator. Write the solutions accurate to the ten-thousandth.

- | | |
|--|---|
| 77. $0.02x^2 - 1.26x + 3.14 = 0$ | 81. $0.3x^2 + \sqrt{2}x + 0.72 = 0$ |
| 78. $0.5x^2 + 0.07x - 5.6 = 0$ | 82. $\sqrt[3]{4}x^2 - \sqrt[3]{2}x - \sqrt{11} = 0$ |
| 79. $\sqrt{2}x^2 - \sqrt{3}x - \sqrt{5} = 0$ | 83. $x^2 + 2\sqrt{15} - 15 = 0$ |
| 80. $x^2 - 2\sqrt{10}x + 10 = 0$ | 84. $0.05x^2 - \sqrt{30} = 0$ |

Applications

Solve.

85.  An orange is thrown down from the top of a building that is 300 feet tall with an initial velocity of 6 feet per second. The distance of the object from the ground can be calculated using the equation $d = 300 - 6t - 16t^2$, where t is the time in seconds after the orange is thrown.
- On a balcony, a cup is sitting on a table located 100 feet from the ground. If the orange is thrown with the right aim to fall into the cup, how long will the orange fall? Round to the nearest hundredth. (**Hint:** The distance is 100 feet.)
 - If the orange misses the cup and falls to the ground, how long will it take for the orange to splatter on the sidewalk? (**Hint:** What is the height of the orange when it hits the ground?)
 - Approximately how much longer would it take for the orange to fall to the sidewalk than it would for the orange to fall into the cup?
86.  Merida is practicing archery with her recurve bow. Her target is the top of a 3-foot tall bale of hay that is 400 feet away. She aims at a 45° angle and shoots the arrow with an initial velocity of 140 feet per second. The height of the arrow can be described by $h = 99t - 16t^2 + 5$, where 99 is the vertical velocity of the arrow, h is the height of the arrow, and t is the time in seconds that passes after the arrow leaves the bow.
- Solve the equation $3 = 99t - 16t^2 + 5$ to determine the time in seconds when the height of the arrow will be 3 feet. Round your answer to the nearest hundredth.
 - When shot at a 45° angle, the horizontal velocity of the arrow is also 99 feet per second. Use this velocity to determine how long will it take the arrow to reach the bale of hay? Round your answer to the nearest hundredth. (**Hint:** Use the $d = rt$ formula.)
 - Did Merida hit the target, undershoot the target, or overshoot the target? (**Hint:** Compare the answers from part a. and part b.)

Writing & Thinking

87. Find an equation of the form $Ax^4 + Bx^2 + C = 0$ that has the four roots ± 2 and ± 3 . Explain how you arrived at this equation.

88. The surface area of a right circular cylinder can be found using the following formula: $S = 2\pi r^2 + 2\pi rh$, where r is the radius of the cylinder and h is the height. Estimate the radius of a circular cylinder of height 30 cm and surface area 300 cm^2 . Explain how you used your knowledge of quadratic equations.

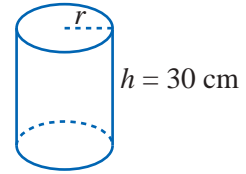

F Cost per Item

In the following example, note that the cost per item is found by dividing the total cost by the number of items sold. The cost per item changes because the total cost remains fixed while the number of items sold changes.

7. An artist has discovered that if she charges x dollars per painting, she can sell $55 - x$ paintings in a month. What is the fewest number of paintings she can produce to make \$250 on her artwork in a month?

Example 7 Application: Finding the Cost per Item

Carol has started selling bracelets online. She estimates that if she charges x dollars for each bracelet, she can sell $19 - x$ bracelets per week. What is the smallest number of bracelets she can sell to make \$90 in one week?

Solution

Let x = price per bracelet

and $19 - x$ = bracelets sold per week.

The total income is the price per object multiplied by the total number of objects sold.

$$x(19 - x) = 90$$

$$19x - x^2 = 90$$

$$0 = x^2 - 19x + 90$$

$$0 = (x - 10)(x - 9)$$

$$x - 10 = 0 \quad x - 9 = 0$$

$$x = 10 \quad \text{or} \quad x = 9$$

If Carol charges \$9 for each bracelet, she will have to sell $19 - 9 = 10$ bracelets to make \$90 in one week. However, if she charges \$10 for each bracelet, she will have to sell $19 - 10 = 9$ bracelets. Therefore, the smallest number of bracelets Carol can sell in a week and still make \$90 that week is 9 bracelets.

Now work margin exercise 7.

Margin Exercise Answers

1. 3 ft and 4 ft 2. 3 hours 3. 4.14 mph 4. In 30 seconds 5. 8 meters 6. 127.3 ft 7. 5 paintings

11.4 Exercises

Concept Check

Fill-in-the-Blank. Complete each sentence using information found in this section.

- Application problems are designed to teach you to _____ carefully, to _____ clearly, and to _____ from English to algebraic expressions and equations.
- You must decide on a method of _____ based on the wording of the problem and your previous experience and knowledge.
- Draw a/an _____ for problems involving geometric figures whenever possible.

True/False. Determine whether each statement is true or false. If a statement is false, explain how it can be changed so the statement will be true. (**Note:** There may be more than one acceptable change.)

- Application problems will always directly tell you which operations to perform.
- The basic formula for distance-rate-time problems is $d = rt$.

Applications

Solve.

- A rectangle has a length 5 m less than twice its width. If the area is 63 m^2 , find the dimensions of the rectangle.
- The length of a rectangle is 2 cm less than 3 times its width. If the area of the rectangle is 225 cm^2 , find the dimensions of the original rectangle.
- The difference between two positive numbers is 9. If the smaller number is added to the square of the larger number, the result is 147. Find the numbers.
- The difference between a positive number and 3 is four times the reciprocal of the number. Find the number.
(**Hint:** The reciprocal of x is $\frac{1}{x}$.)

- The Wilsons have a rectangular swimming pool that is 10 ft longer than it is wide. The pool is completely surrounded by a concrete deck that is 6 ft wide. The total area of the pool and the deck is 1344 ft^2 . Find the dimensions of the pool.

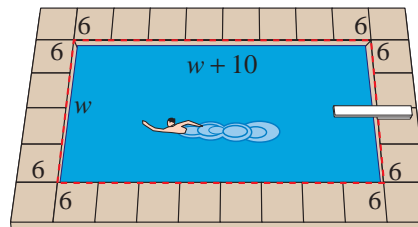

- Each side of a square is increased by 10 cm. The area of the resulting square is 9 times the area of the original square. Find the length of the sides of the original square.
- If 5 meters are added to each side of a square, the area of the resulting square is four times the area of the original square. Find the length of the sides of the original square.
- The diagonal of a rectangle is 13 m. The length is 2 m more than twice the width. Find the dimensions of the rectangle.
- The length of a rectangle is 4 m more than its width. If the diagonal is 20 m, what are the dimensions of the rectangle?
- An orchard has 2030 trees. The number of trees in each row is 12 more than twice the number of rows. How many trees are in each row?
- A rectangular auditorium seats 960 people. The number of seats in each row is 16 more than the number of rows. Find the number of seats in each row.
- An apartment building has the same number of units on each floor. The building has five times as many units per floor as number of floors, and there are 405 units total. How many floors does the building have?

13. A farmer fenced in a 198-square-meter portion of his field with 58 meters of fencing. What are the length and width of the field? (**Hint:** The length plus the width is equal to half of the perimeter.)

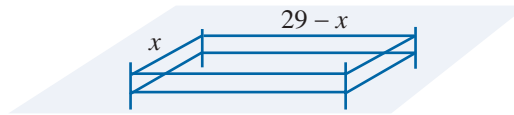

- a. Write an equation to express the area of the fenced-in field.
 b. Solve the equation from part a. for the variable.
 c. Use the answer from part b. to determine the length and width of the fenced-in field.
14. A large U-Haul truck is 8 ft tall. The length of the truck is 4 ft longer than three times the width. What are the dimensions of the truck if the volume is 1590 ft³?

15. A photograph 9 in. wide and 12 in. long is surrounded by a frame of uniform thickness. The area of the frame itself, not including the center, is 162 in.² Find the thickness of the frame.

Area of Frame = 162 sq. in.



16. The Mona Lisa is a famous painting by Leonardo da Vinci. The painting is 30 in. by 21 in. It is surrounded by a frame of uniform thickness whose area (not including the center) is 756 in.² Find the thickness of the frame.
17. A 40-volt generator with a resistance of 4 ohms delivers power externally of $40I - 4I^2$ watts, where I is the current measured in amperes. Find the current needed for the generator to deliver 100 watts of power.
18. Find the current needed for the 40-volt generator in Exercise 17 to deliver 64 watts of power.
19. Raymond operates a small sign-making business. He finds that if he charges x dollars for each sign, he sells $40 - x$ signs per week. What is the least number of signs he can sell to have an income of \$336 in one week?
20. It costs Mrs. Snow \$3 to build a picture frame. She estimates that if she charges x dollars each, she can sell $60 - x$ frames per week. What is the lowest price necessary to make a profit of \$432 each week?
21. Samuel operates a small peanut stand. He estimates that he can sell 600 bags of peanuts per day if he charges 50¢ for each bag. He determines that he can sell 20 more bags for each 1¢ reduction in price.
- a. What would be his revenue for one day if he charged 48¢ per bag?
 b. What should he charge in order to have receipts of \$315?
22. A sporting goods store owner estimates that if he sells a certain model of basketball shoes for x dollars a pair, he will be able to sell $125 - x$ pairs. Find the price if his sales are \$3750. Is there more than one possible answer?

23. Mr. Prince owns a 15-unit apartment complex. If all units are rented, the rent for each apartment is \$700 per month. Each time the rent is increased by \$70, he will lose 1 tenant. What is the rental rate if he receives \$10,920 monthly in rent? (**Hint:** Let x represent the number of empty units.)

24. The Ski Club is planning to charter a bus to a ski resort. The cost will be \$900 and each member will share the cost equally. If the club had 15 more members, the cost per person would be \$10 less. How many are in the club now? (**Hint:** If x = number in club now, $\frac{900}{x}$ = cost per person.)



25. A motorboat takes a total of 2 hours to travel 8 miles downstream and 4 miles back on a river that is flowing at a rate of 2 mph. Find the rate of the boat in still water.

| | Rate | Time | Distance |
|-----------|----------|------|----------|
| Going | x | ? | 200 |
| Returning | $x - 10$ | ? | 200 |

26. A small motorboat travels 12 mph in still water. It takes 2 hours longer to travel 45 miles going upstream than it does going downstream. Find the rate of the current. (**Hint:** $12 + c$ = rate going downstream and $12 - c$ = rate going upstream.)

27. Recently Mr. and Mrs. Roberts spent their vacation in San Francisco, which is 540 miles from their home. Being a little reluctant to return home, the Roberts took 2 hours longer on their return trip and their average speed was 9 mph slower than when they were going. What was their average rate of speed as they traveled from home to San Francisco?

28. Lisa traveled to a college that is located 200 miles from the city where she works to train customers how to use the software that her company sells. Due to a traffic jam, her average speed returning was 10 miles per hour less than her average speed going to the college. The total travel time to and from the college was 9 hours. What was Lisa's average speed going to the college?

- a. Use the table to set up a rational equation to describe the situation. Use the variable x to represent the average speed going to the college. (**Hint:** The sum of the times that it took Lisa to travel to and from the college is 9 hours.)

| Distance (d) | ÷ | Rate (r) | = | Time $\left(t = \frac{d}{r}\right)$ |
|------------------|---|--------------|---|-------------------------------------|
| Going | | | | |
| Returning | | | | |

- b. Solve the equation from part a. Round your answer to the nearest tenth.
- c. Which solution from part b. makes sense in the context of the situation? Explain your reasoning.
- d. Use the answer from part c. to answer the question from the problem statement.

29. The Blumin Garden Club planned to give their president a gift of appreciation costing \$120 and to divide the cost evenly. In the meantime, 5 members dropped out of the club. If it now costs each of the remaining members \$2 more than originally planned, how many members initially participated in the gift buying?
(Hint: If x = number in club initially, $\frac{120}{x}$ = cost per member.)
30. A manufacturing crew needs to assemble 1000 boxes per day, divided equally among the workers. One day, three workers call in sick, and the remaining members each need to assemble 75 more boxes than usual. How many workers are on the manufacturing crew?
31. A toy football launcher can be used to launch a football straight up from a height of one foot at an initial velocity of 60 feet per second. The height of the ball can be found by using the equation $h = -16t^2 + 60t + 1$. When will the football hit the ground? Round your answer to the nearest tenth.
32. A bullet is fired straight up from a shoulder-height of 5 feet with a muzzle velocity of 360 feet per second. The height of the bullet can be found by using the equation $h = -16t^2 + 360t + 5$. When will the bullet hit the ground? Round your answer to the nearest tenth.
33. A woman and her daughter can paint their cabin in 3 hours. Working alone it would take the daughter 8 hours longer than it would the mother. How long would it take the mother to paint the cabin alone?
34. Two employees together can prepare a large order in 2 hrs. Working alone, one employee takes three hours longer than the other. How long does it take each person working alone?
35. Two pipes can fill a tank in 8 minutes if both are turned on. If only one is used it would take 30 minutes longer for the smaller pipe to fill the tank than the larger pipe. How long will it take the smaller pipe to fill the tank?
36. A farmer and his son can plow a field with two tractors in 4 hours. If it would take the son 6 hours longer than the father to plow the field alone, how long would it take each if they worked alone?
37. Jack and Diane are decorating a nursery room for their baby, who will be born in a few months. Working together, they can completely decorate the nursery in 4 hours. Working alone, it would take Diane 6 hours longer to decorate the nursery than it would take Jack. How long would it take Jack and Diane to decorate the nursery by themselves?

- a. Use the table to set up a rational equation to describe the situation. Use the variable x to represent the time it takes Jack to decorate the nursery by himself.

| Person(s) | Time of Work (in Hours) | Part of Work Done in 1 Hour |
|-----------|-------------------------|-----------------------------|
| Jack | | |
| Diane | | |
| Together | | |

- b. Solve the equation from part a.
- c. Which solution from part b. makes sense in the context of the situation? Explain your reasoning.
- d. Use the answer from part c. to answer the question from the problem statement.

38.  A ball is thrown upward with an initial velocity of 32 ft/sec from the edge of a cliff near the beach. The cliff is 50 ft above the beach. The height of the ball can be found by using the equation $h = -16t^2 + 32t + 50$, where t is measured in seconds.
- When will the ball be 66 feet above the beach?
 - When will the ball be 30 feet above the beach?
 - In about how many seconds will the ball hit the beach?

39. The height of a projectile fired upward from the ground with a velocity of 128 ft/sec is given by the formula $h = -16t^2 + 128t$.

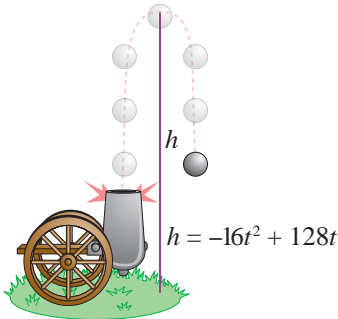



- When will the projectile be 256 feet above the ground?
- Will the projectile ever be 300 feet above the ground? Explain.
- When will the projectile be 240 feet above the ground?
- In how many seconds will the projectile hit the ground?

40.  A ladder is 30 ft long and you want to place the base of the ladder 10 ft from the base of a building. About how far up the building (to the nearest tenth of a foot) will the ladder reach?

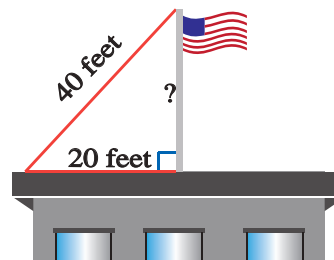

41.  A flag pole is on top of a building and is held in place by steel cables attached to the top of the pole. If one such cable is 40 ft long and is attached at a point on the roof of the building 20 ft from the base of the flag pole, what is the length of the flag pole (to the nearest tenth of a foot)?



42.  A landscaper was given the task to create a triangular flower garden in the corner of an office building. The landscaper has 12 feet of low fencing to use as a border along one side of the garden. The final garden will have the shape shown in the figure. The landscaper needs to know the remaining side lengths of the triangle to determine the area he will need to cover with fresh topsoil.

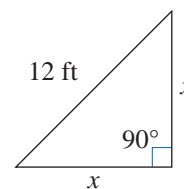

- a. Use the Pythagorean Theorem to set up an equation which describes the relationship between the side lengths of the flower garden.
- b. Solve the equation from part a. for the variable. Round your answer(s) to the nearest tenth.
- c. Which solution from part b. makes sense in the context of the situation? Explain your reasoning.
- d. Use the answer from part c. to determine the area that the landscaper will need to cover with topsoil.

Writing & Thinking

43. Suppose that you are to solve an applied problem and the solution leads to a quadratic equation. You decide to use the quadratic formula to solve the equation. Explain what restrictions you must be aware of when you use the formula.

Now, press the **TRACE** key and move the cursor around to estimate the location of points. Three such locations are shown here.

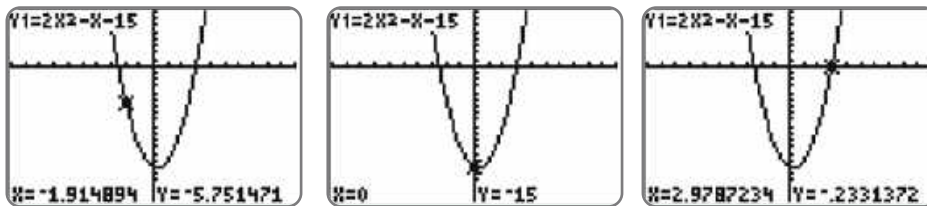

Now work margin exercise 6.

Margin Exercise Answers

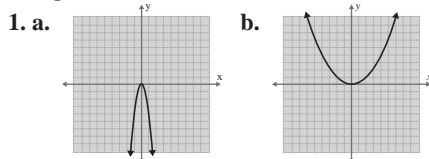

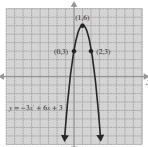
2. $x = -3$; vertex: $(-3, 12)$; x -int: $(-3 + 2\sqrt{3}, 0), (-3 - 2\sqrt{3}, 0)$; y -int: $(0, 3)$ 3. $x = 1$; vertex: $(1, 3)$; x -int: none; y -int: $(0, 4)$ 4. It will take the ball 1.5 sec to reach its maximum height of 36 ft. 5. Two sides of the lot are 90 yards and the third side is 180 yards for a maximum area of 16,200 square yards. 6.  points include $(0, 3)$, $(1, 6)$, and $(2, 3)$

11.5 Exercises

Concept Check

Fill-in-the-Blank. Complete each sentence using information found in this section.

- The curved graph of a quadratic function is called a/an _____.
- The “turning point” of the graph of a quadratic function is called the _____.
- For any real number x , x^2 _____ 0.
- The points where a parabola crosses the x -axis, if any, are the x -intercepts. These points are also called the _____ of the function.
- The x -intercepts, or _____, of a function can be found by substituting _____ for y and solving the resulting quadratic equation.

True/False. Determine whether each statement is true or false. If a statement is false, explain how it can be changed so the statement will be true. (**Note:** There may be more than one acceptable change.)

- The graph of a quadratic function is a mirror of itself across the line, or axis, of symmetry.

7. The vertex of a vertical parabola is the lowest point on the parabola.
8. The maximum or minimum value of a quadratic function written in general form can be found by letting $x = -\frac{b}{2a}$ and solving for y .
9. When the solutions to a quadratic function are nonreal, the entire graph lies either completely above or below the x -axis.

Practice

Graph the function. See Example 1.

1. $y = -2x$

3. $y = \frac{1}{5}x$

2. $y = 4x$

4. $y = -\frac{1}{4}x$

For each quadratic function use the formula $x = -\frac{b}{2a}$ to find the line of symmetry and the vertex. Then find the x -intercepts and the y -intercept. Graph the function. See Examples 3 and 4.

5. $y = -3x^2 + 6x - 3$

10. $y = 5x^2 + 10x + 7$

6. $y = x^2 - 2x - 8$

11. $y = x^2 + 2x + 1$

7. $y = x^2 - 4x + 3$

12. $y = x^2 + 8x + 7$

8. $y = x^2 + 6x + 5$

13. $y = -x^2 - 2x - 2$

9. $y = -2x^2 + 8x - 9$

14. $y = 2x^2 + 4x - 6$

Graph the two given functions and answer the following questions:

- a. Are the graphs the same?
- b. Do the functions have the same zeros?
- c. Briefly, discuss your interpretation of the results in parts a. and b.

15.
$$\begin{cases} y = x^2 - 3x - 10 \\ y = -x^2 + 3x + 10 \end{cases}$$

17.
$$\begin{cases} y = 2x^2 - 5x - 3 \\ y = -2x^2 + 5x + 3 \end{cases}$$

16.
$$\begin{cases} y = x^2 - 5x + 6 \\ y = -x^2 + 5x - 6 \end{cases}$$

18.
$$\begin{cases} y = -4x^2 - 15x + 4 \\ y = 4x^2 + 15x - 4 \end{cases}$$

Use the CALC features of the calculator to find the zeros of the function. (**Hint:** The zero item on the CALC menu will locate the zeros of the function.) Round answers to nearest ten-thousandth.

19. $y = x^2 - 2x - 2$

22. $y = -x^2 - 2x + 7$

20. $y = 3x^2 + x - 1$

23. $y = x^2 + 3x + 3$

21. $y = -2x^2 + 2x + 5$

24. $y = -4x^2 - x - 6$

Use a graphing calculator to graph each function by pressing $\boxed{Y=}$ and entering the function. Find the coordinates of the maximum as follows. Round answers to nearest ten-thousandth.

Step 1: Press CALC ($\boxed{2nd}$ \boxed{TRACE}).

Step 2: Press or choose maximum.

Step 3: Follow the directions for moving the cursor to Left Bound?, Right Bound?, and Guess?. (Press \boxed{ENTER} each time.)

25. $y = 4x - x^2$

27. $y = -8 + 4x - x^2$

26. $y = 1 - 2x - x^2$

28. $y = 3 - 2x - x^2$

Use a graphing calculator to graph each function by pressing $\boxed{Y=}$ and entering the function. Find the coordinates of the minimum as follows. Round answers to nearest ten-thousandth.

Step 1: Press CALC ($\boxed{2nd}$ \boxed{TRACE}).

Step 2: Press or choose minimum.

Step 3: Follow the directions for moving the cursor to Left Bound?, Right Bound?, and Guess?. (Press \boxed{ENTER} each time.)

29. $y = x^2 - 8x + 15$

31. $y = 2x^2 + 4x + 3$

30. $y = x^2 + 10x + 22$

32. $y = 3x^2 - 6x + 5$

Applications

Use the function $h = -16t^2 + v_0t + h_0$, where h is the height of the object after time t , v_0 is the initial velocity, and h_0 is the initial height. See Example 5.

33. A ball is thrown vertically upward from the ground with an initial velocity of 112 ft/s.
- When will the ball reach its maximum height?
 - What will be the maximum height?
34. A water rocket is launched from the ground and has an initial velocity of 104 ft/s.
- When will the rocket reach its maximum height?
 - What will be the maximum height?
35. A stone is projected vertically upward from a platform that is 20 feet high at a rate of 160 feet per second.
- When will the stone reach its maximum height?
 - What will be the maximum height?
36. A cannonball is projected vertically upward from a platform that is 32 feet high at a rate of 128 feet per second.
- When will the cannonball reach its maximum height?
 - What will be the maximum height?

Solve.

-
37. A retailer sells fitness trackers. He estimates that by selling them for x dollars each, he will be able to sell $100 - x$ fitness trackers each month.
- What price will yield maximum revenue?
 - What will be the maximum revenue?
38. Mrs. Richey can sell 72 picture frames each month if she charges \$24 each. She estimates that for each \$1 increase in price, she will sell 2 fewer frames.
- Find the price that will yield maximum revenue.
 - What will be the maximum revenue?
39. A store owner estimates that by charging x dollars each for a certain lamp, he can sell $40 - x$ lamps each week. What price will give him maximum sales revenue?
40. The band Pumpkin Riot estimates that by selling T-shirts for x dollars each, they can sell $250 - 10x$ T-shirts per show they play. Determine the price per T-shirt that will give the band maximum sales revenue.
41. A nature reserve plans to fence off an area of land to restore balance to the native plant and wildlife populations. The fence will be on three sides and form a rectangle, with a river along the fourth side. The planning committee determines they have enough funds to install 600 yards of fencing.
- What dimensions should the fence have to enclose the maximum area?
 - What is the maximum area that can be enclosed?
42. A contractor is to build a six-foot-high brick wall to enclose a rectangular garden. The wall will be on three sides of the rectangle while the fourth side is a building. The owner wants to enclose the maximum area but only wants to pay for 150 feet of wall. What dimensions should the contractor make the garden?

Writing & Thinking

43. Discuss the following features of the general quadratic function $y = ax^2 + bx + c$.
- What type of curve is its graph?
 - What is the value of x at its vertex?
 - What is the equation of the line of symmetry?
 - Does the graph always cross the x -axis? Explain.
44. Discuss the discriminant of the general quadratic equation $ax^2 + bx + c = 0$ and how the value of the discriminant is related to the graph of the corresponding quadratic function $y = ax^2 + bx + c$.