

Note that in the second part of the definition  $-a$  is positive if  $a$  is negative. For example, if  $a = -5$ , then  $-a = -(-5) = +5$ . Thus,

$$|a| = |-5| = -(-5) = +5.$$

#### Example 5: Absolute Value

Find the absolute value of each of the numbers **a.**  $-10$ , **b.**  $-2.3$ , **c.**  $4.5$ , and **d.**  $0$ .

#### Solution

**a.**  $|-10| = -(-10) = 10$

**b.**  $|-2.3| = -(-2.3) = 2.3$

**c.**  $|4.5| = 4.5$

**d.**  $|0| = 0$

#### Example 6: Absolute Value Equations

Determine what real numbers satisfy each of the following equations.

**a.**  $|x| = 4$

**b.**  $|x| = -1.7$

#### Solution

**a.** Since  $|4| = 4$  and  $|-4| = 4$ ,  $x$  can be either  $4$  or  $-4$ .

**b.** This equation has no solution ( $\emptyset$ ) because the absolute value of any real number is nonnegative.

## 0.1 EXERCISES

### PRACTICE

In Exercises 1–6, list the numbers from the set

$$A = \left\{ -6, -\sqrt{7}, -\sqrt{4}, -\frac{5}{4}, -1.2, 0, \frac{3}{8}, \sqrt{3}, \sqrt{10}, \sqrt{16}, 5.2 \right\}$$

that belong to each of the sets described. Then graph each set of answers on a number line. (**Hint:** Using a calculator to convert numbers in set  $A$  to decimal form may be helpful.)

1.  $\{x \mid x \text{ is a whole number}\}$

2.  $\{x \mid x \text{ is an integer}\}$

3.  $\{x \mid x \text{ is a positive integer}\}$

4.  $\{x \mid x \text{ is a irrational number}\}$

5.  $\{x \mid x \text{ is a rational number}\}$

6.  $\{x \mid x \text{ is a real number}\}$

In Exercises 7–16, graph each of the sets of real numbers; then write each as an interval using the symbol  $-\infty$  or  $\infty$ .

7.  $\{x|x \leq 7\}$

8.  $\{x|x < -9\}$

9.  $\{x|x > -3.4\}$

10.  $\{x|x \geq 4.9\}$

11.  $\{x|x \leq 0\}$

12.  $\{x|x > 0\}$

13.  $\left\{x \mid x < \frac{16}{3}\right\}$

14.  $\left\{x \mid x < -\frac{8}{3}\right\}$

15.  $\left\{x \mid x \geq -\frac{7}{2}\right\}$

16.  $\left\{x \mid x \geq -\frac{11}{4}\right\}$

In Exercises 17–26, find the value of each expression.

17.  $|1.4|$

18.  $|-5.3|$

19.  $\left|-\frac{3}{8}\right|$

20.  $\left|\frac{4}{3}\right|$

21.  $|-\sqrt{2}|$

22.  $|0|$

23.  $|-4| + |8|$

24.  $|2| + |-8.4|$

25.  $|-3.6| - |-4.2|$

26.  $|-9.2| - |6.6|$

In Exercises 27–36, find the real numbers that satisfy the given equation.

27.  $|x| = 8$

28.  $|x| = 10.3$

29.  $|x| = \frac{7}{16}$

30.  $|x| = \frac{9}{5}$

31.  $|x| = -2.5$

32.  $|x| = \sqrt{3}$

33.  $|x| = 3\sqrt{2}$

34.  $|x| = -0.8$

35.  $|x| = x$

36.  $|x| = -x$

### WRITING & THINKING

In Exercises 37–42, choose the word that correctly completes each statement.

37. If  $x$  is a rational number, then  $x$  is (never, sometimes, always) a real number.

38. If  $x$  is a rational number, then  $x$  is (never, sometimes, always) an irrational number.

39. If  $x$  is an integer, then  $x$  is (never, sometimes, always) a whole number.

40. If  $x$  is a real number, then  $x$  is (never, sometimes, always) a rational number.

41. If  $x$  is a rational number, then  $x$  is (never, sometimes, always) an integer.

42. If  $x$  is a positive integer, then  $x$  is (never, sometimes, always) a whole number.

43. Let  $x = 0.999\overline{9}$ . Is  $x = 1$  or is  $x < 1$ ? Is  $x$  a rational number?

## Solution

$$\text{a. } \frac{2x^3 \cdot 6y}{4xy^{-1}} = \frac{12x^3y}{4xy^{-1}} = 3x^{3-1}y^{1-(-1)} = 3x^2y^2$$

Simplify the constants first; then apply property 5.

$$\begin{aligned} \text{b. } \frac{8xy^{-2}}{2x^2y^{-2}} &= 4x^{1-2}y^{-2-(-2)} \\ &= 4x^{-1}y^0 = 4x^{-1} \cdot 1 = 4x^{-1} = \frac{4}{x} \end{aligned}$$

Simplify the constants first; then apply properties 5, 2, and 3 (in that order).

## Example 4: Simplifying Expressions with Exponents

Rewrite the expression  $\left(\frac{3ab^{-3}}{a^{-2}b^3}\right)^{-3}$  without parentheses and with no variables in a denominator. Express constants without exponents.

## Solution

$$\begin{aligned} \left(\frac{3ab^{-3}}{a^{-2}b^3}\right)^{-3} &= (3a^3b^{-6})^{-3} = 3^{-3}(a^3)^{-3}(b^{-6})^{-3} \\ &= 3^{-3}a^{-9}b^{18} = \frac{1}{27}a^{-9}b^{18} \end{aligned}$$

Using properties 5, 8, 7, and 4 (in that order)

## 0.2 EXERCISES

 PRACTICE

In Exercises 1–8, evaluate each expression.

1.  $7^3$

2.  $3^4$

3.  $6^{-2}$

4.  $5^{-3}$

5.  $-2^4$

6.  $(-4)^3$

7.  $-2 \cdot 5^2$

8.  $3 \cdot 2^{-4}$

In Exercises 9–26, simplify each expression so that it contains only positive exponents. Assume that all variables represent nonzero real numbers.

9.  $x^{-2}$

10.  $t^{-3}$

11.  $5y^{-1}$

12.  $7x^{-2}$

13.  $x^2 \cdot x^5$

14.  $y^4 \cdot y$

15.  $x^3 \cdot x^{-2}$

16.  $b^2 \cdot b^{-4}$

17.  $x^{-5} \cdot x^{-2}$

18.  $x^4 \cdot x^{-5}$

19.  $a^0 \cdot a^{-3}$

20.  $x^3 \cdot x^{-1}$

21.  $\frac{y^5}{y^3}$

22.  $\frac{s^7}{s^4}$

23.  $\frac{x^8}{x^3}$

24.  $\frac{x^8}{x^2}$

25.  $\frac{x^3}{x^6}$

26.  $\frac{a^0}{a^4}$

In Exercises 27–50, simplify each expression. Write each answer without parentheses and with no variables in a denominator. Assume that all variables represent nonzero real numbers.

27.  $\frac{x^2}{x^{-1}}$

28.  $\frac{t^4}{t^{-4}}$

29.  $\frac{b^2}{b^{-2}}$

30.  $\frac{x}{x^{-3}}$

31.  $\frac{x^5 x^{-2}}{x^{-3}}$

32.  $\frac{y^2 y^{-3}}{y^4}$

33.  $\frac{a^6 a^0}{a^{-2}}$

34.  $\frac{x^6 x^{-2}}{x^4}$

35.  $\frac{y^8 y^{-3}}{(y^2)^3}$

36.  $\frac{(s^{-2})^3}{ss^{-3}}$

37.  $\frac{(x^{-2})^4}{x^{-2} x^{-1}}$

38.  $\frac{t^3 t^{-5}}{(t^2)^4}$

39.  $\left(\frac{x^2 x^{-1}}{x^5 x}\right)^{-2}$

40.  $\left(\frac{x^{-3} x^0}{x^2 x}\right)^{-3}$

41.  $\frac{a^{-1} b^2}{3ab^{-5}}$

42.  $\frac{5x^3 y^{-1}}{6x^{-2} y^{-3}}$

43.  $\frac{4x^5 y^3}{3x^{-1} y^5}$

44.  $\frac{9s^{-4} t^2}{2st^{-3}}$

45.  $\left(\frac{2x^2 y^{-1}}{3xy^2}\right)^{-3}$

46.  $\left(\frac{-3x^{-2} y^4}{x^0 y^3}\right)^{-1}$

47.  $\left(\frac{6st}{s^2 t^{-3}}\right)^{-2}$

48.  $\left(\frac{2xy^4}{3x^2 y^2}\right)^{-3}$

49.  $\left(\frac{5^{-1} x^3 y^{-2}}{xy^{-1}}\right)^2$

50.  $\left(\frac{a^2 b^{-3}}{3^{-1} a^{-1} b}\right)^3$

### Properties of Square Roots

In the following properties,  $a$  and  $b$  are positive real numbers.

$$1. \sqrt{ab} = \sqrt{a} \cdot \sqrt{b}$$

$$2. \sqrt{\frac{a}{b}} = \frac{\sqrt{a}}{\sqrt{b}}$$

The squares of the positive integers are called **perfect square numbers**. Thus, the perfect squares are

1, 4, 9, 16, 25, 36, 49, 64, 81, 100, 121, 144, and so on.

Expressions involving square roots are considered simplified if the radical contains no square factors. Thus  $\sqrt{24}$  is not simplified because 24 has the square factor 4. We can simplify  $\sqrt{24}$  as

$$\sqrt{24} = \sqrt{4 \cdot 6} = \sqrt{4} \cdot \sqrt{6} = 2\sqrt{6}.$$

### ⚠ CAUTION

Note the following common errors. These equations are *almost always false*.

#### Incorrect Equations

- a.  $\sqrt{a+b} = \sqrt{a} + \sqrt{b}$  Let  $a = 64$  and  $b = 36$ .  
 Then  $\left. \begin{array}{l} \sqrt{a+b} = \sqrt{64+36} = \sqrt{100} = 10 \\ \sqrt{a} + \sqrt{b} = \sqrt{64} + \sqrt{36} = 8 + 6 = 14 \end{array} \right\}$  are not equal.
- b.  $\sqrt{a^2 + b^2} = a + b$  Let  $a = 8$  and  $b = 6$ .  
 Then  $\left. \begin{array}{l} \sqrt{a^2 + b^2} = \sqrt{64+36} = \sqrt{100} = 10 \\ a + b = 8 + 6 = 14 \end{array} \right\}$  are not equal.
- c.  $(a+b)^2 = a^2 + b^2$  Let  $a = 6$  and  $b = 8$ .  
 Then  $\left. \begin{array}{l} (a+b)^2 = (6+8)^2 = 14^2 = 196 \\ a^2 + b^2 = 36 + 64 = 100 \end{array} \right\}$  are not equal.

## 0.3 EXERCISES

### 💡 PRACTICE

In Exercises 1–32, simplify each expression. Assume that all variables represent positive real numbers.

$$1. 64^{\frac{1}{3}}$$

$$2. 144^{\frac{1}{2}}$$

$$3. 16^{\frac{3}{4}}$$

$$4. (-8)^{\frac{2}{3}}$$

$$5. 25^{-\frac{3}{2}}$$

$$6. 4^{-\frac{5}{2}}$$

$$7. -81^{\frac{1}{4}}$$

$$8. -49^{\frac{3}{2}}$$

9. $32^{\frac{2}{5}}$	10. $64^{-\frac{2}{3}}$	11. $x^2 \cdot x^{\frac{1}{2}}$	12. $x^3 \cdot x^{\frac{2}{3}}$
13. $x^{-\frac{1}{2}} \cdot x^{\frac{1}{3}}$	14. $x^{\frac{3}{4}} \cdot x^{\frac{1}{2}}$	15. $a^2 \cdot a^{-\frac{2}{5}}$	16. $x^{-3} \cdot x^{\frac{4}{3}}$
17. $\frac{x}{x^{\frac{2}{3}}}$	18. $\frac{t^2}{t^{\frac{1}{2}}}$	19. $\frac{x^{\frac{1}{4}}}{x^2}$	20. $\frac{y^{\frac{3}{4}}}{y^4}$
21. $\frac{b^{\frac{4}{5}}}{b^{\frac{1}{2}}}$	22. $\frac{x^{\frac{3}{2}}}{x^{-\frac{1}{3}}}$	23. $\frac{s^{\frac{3}{4}}}{s^{-\frac{1}{8}}}$	24. $\frac{x^{\frac{1}{2}}}{x^{\frac{4}{3}}}$
25. $\frac{x^{\frac{1}{2}} \cdot x^{-\frac{3}{4}}}{x^{-\frac{1}{2}}}$	26. $\frac{y^{\frac{2}{3}} \cdot y^{\frac{4}{3}}}{y^{-2}}$	27. $\frac{x^{\frac{3}{2}} \cdot x^{\frac{4}{5}}}{x^{-\frac{1}{2}} \cdot x^2}$	28. $\frac{x^{-\frac{2}{3}} \cdot x^{\frac{1}{2}}}{x \cdot x^{-\frac{3}{2}}}$
29. $\left(\frac{27x^3y^6}{x^{-3}}\right)^{\frac{1}{3}}$	30. $\left(\frac{16a^{-4}b^3}{ab^{-1}}\right)^{\frac{1}{4}}$	31. $\frac{(16s^2t)^{\frac{1}{4}}}{\left(5s^{\frac{1}{3}}t^{-\frac{1}{2}}\right)^2}$	32. $\frac{(25x^2y^{-1})^{\frac{1}{2}}}{\left(5x^{\frac{1}{5}}y^{\frac{3}{5}}\right)^3}$

In Exercises 33–42, change each expression to an equivalent expression in radical notation. Assume that each variable expression represents a positive real number.

33. $y^{\frac{1}{2}}$	34. $x^{\frac{2}{5}}$	35. $x^{-\frac{1}{4}}$	36. $x^{-\frac{1}{2}}$
37. $(x-2)^{\frac{4}{5}}$	38. $(5a+3)^{\frac{2}{3}}$	39. $2(y^2+4)^{-\frac{1}{2}}$	40. $7(x^2+8)^{\frac{1}{3}}$
41. $\frac{-2}{7}(t^2-4)^{-\frac{1}{4}}$	42. $\frac{5}{8}(x^2+6)^{-\frac{1}{2}}$		

In Exercises 43–52, change each expression to an equivalent expression in exponential notation. Write each answer with no variables in a denominator. Assume that each variable expression represents a positive real number.

43. $\sqrt[4]{x}$	44. $\sqrt[3]{b}$	45. $\frac{1}{\sqrt[4]{s}}$	46. $\frac{1}{\sqrt[5]{x^2}}$
47. $\sqrt[3]{(y+10)^2}$	48. $\sqrt[4]{(x+1)^3}$	49. $\frac{1}{\sqrt[3]{a^2+2}}$	50. $\frac{2}{5\sqrt[3]{x^2-6}}$
51. $\frac{4x}{9\sqrt[3]{(x+5)^2}}$	52. $\frac{3y}{5\sqrt[3]{y^3+8}}$		

In Exercises 53–60, simplify each radical expression. Assume that each variable represents a positive real number.

53. $\sqrt{48}$	54. $\sqrt{175}$	55. $\sqrt{\frac{9}{16}}$	56. $\sqrt{\frac{49}{225}}$
57. $\sqrt{150x}$	58. $\sqrt{112a}$	59. $\sqrt{108t^3}$	60. $\sqrt{216x^3}$

### Example 9: Using Special Products

Factor each of the following polynomials by using the list of special products.

a.  $4x^2 - 25$

b.  $x^2 + 12x + 36$

c.  $x^3 - 125$

### Solution

a.  $4x^2 - 25$  is the difference of two squares:  $4x^2 - 25 = (2x + 5)(2x - 5)$ .

b.  $x^2 + 12x + 36$  is a perfect square trinomial with  $A = \frac{1}{2}(12) = 6$  and  $A^2 = 6^2 = 36$ :

$$x^2 + 12x + 36 = (x + 6)^2.$$

c.  $x^3 - 125$  is the difference of two cubes with  $A^3 = 5^3$ :

$$x^3 - 125 = (x - 5)(x^2 + 5x + 25).$$

## 0.4 EXERCISES

### PRACTICE

In Exercises 1–14, perform the indicated operation and simplify the expressions.

1.  $(x + 3x^2) + (5 - x^2)$

2.  $(x^2 + 2x - 4) + (x^2 - 4)$

3.  $(8a^2 + 5a + 2) + (-3a^2 + 9a - 4)$

4.  $(3x^2 + 5x - 4) + (2x^2 - 2x + 4)$

5.  $(2x^2 + 3x + 8) - (x^2 - 5x + 6)$

6.  $(4x^3 - 7x^2 + 3x) - (-2x^3 + 5x - 1)$

7.  $(8x^2 + 9) - (4x^2 - 3x - 2)$

8.  $(y^3 + 4y^2 - 7) - (3y^3 + y^2 + 2y + 1)$

9.  $(a^2 - 3ab + b^2) + (2a^2 - 5ab - b^2)$

10.  $(7x^2 - 2xy + 3y^2) + (-3x^2 - 2xy + 5y^2)$

11.  $(-3x^2 - 2xy + 5y^2) - (4x^2 + 3xy)$

12.  $(5x^2 - 3xy + 7y^2) - (6x^2 - 9xy + 8y^2)$

13.  $2x^2(3x^2 + 5x - 1)$

14.  $-4y^2(2y^2 + 5y - 4)$

Fill in the missing expressions in Exercises 15–17.

15.  $(2x + 3y)^2 = 4x^2 + \underline{\hspace{2cm}} + 9y^2$

16.  $(9x - 5y)^3 = 729x^3 - 3(\underline{\hspace{2cm}})x^2y + 3(\underline{\hspace{2cm}})xy^2 - 125y^3$

17.  $(3x^2 + 8y)^2 = 9(\underline{\hspace{2cm}}) + 48(\underline{\hspace{2cm}}) + 64(\underline{\hspace{2cm}})$

In Exercises 18–33, find the products.

18.  $(3x - 8)(x - 5)$

19.  $(7x + 6)(2x - 3)$

20.  $(5x+11)(3x-4)$

21.  $(3x-4)(4x-3)$

22.  $(3x+1)^2$

23.  $(4x-3)^2$

24.  $(7x-4y)^2$

25.  $(3x+2y)^2$

26.  $(4x-5)(4x+5)$

27.  $(6x+y)(6x-y)$

28.  $3x^2(1+3x)$

29.  $2x(x^2+3x-4)$

30.  $(x+2)(x^2-2x+4)$

31.  $(x+3)(x^2-3x+9)$

32.  $(y-5)(y^2+5y+25)$

33.  $(x+2y)(x^2-2xy+4y^2)$

In Exercises 34–39, simplify each expression.

34.  $5a+2(a-3)-(3a+7)$

35.  $11+[3x-2(1+5x)]$

36.  $3y-[5-7(y+2)-6y]$

37.  $10t-[8-5(3-2t)-7t]$

38.  $x(x-5)+[6x-x(4-x)]$

39.  $x(2x+1)-[5x-x(2x+3)]$

Fill in the missing expressions in Exercises 40 and 41.

40.  $11x^2-99y^2=11(x-\underline{\hspace{1cm}})(x+\underline{\hspace{1cm}})$

41.  $16x^3+54y^3=2(2x+\underline{\hspace{1cm}})(\underline{\hspace{1cm}}x^2-\underline{\hspace{1cm}}xy+9y^2)$

In Exercises 42–60, factor each expression completely. (Each factor should have integer coefficients.)

42.  $x^2+6x-27$

43.  $s^2-5s-14$

44.  $x^2+27x+50$

45.  $x^2+11x-26$

46.  $2x^2-98$

47.  $4b^3-64b$

48.  $9y^3-16y$

49.  $27a^2-12$

50.  $x^2+6xy+9y^2$

51.  $x^6-1$

52.  $x^5-x^3$

53.  $25x^8-16$

54.  $125y^6-27z^3$

55.  $2t^3+16y^3$

56.  $1600x^2+880xy+121y^2$

57.  $s^4-1$

58.  $3a^2+12ab+12b^2$

59.  $100xy^2+200xy+100x$

60.  $x^{21}-x^{19}$



### WRITING & THINKING

61. If you were teaching Algebra I to ninth grade students, how would you explain the difference between a variable and a constant in an algebraic expression?

The following two characteristics of lines are useful:

**1. Parallel lines have the same slope.**

For example, the lines  $y = 2x + 1$  and  $y = 2x - 3$  are parallel because they have the same slope, 2.

**2. Perpendicular lines have slopes that are negative reciprocals of each other.**

For instance, the lines  $y = \frac{2}{3}x + 1$  and  $y = -\frac{3}{2}x + 5$  are perpendicular because their slopes are negative reciprocals. Note that the product of their slopes is  $\frac{2}{3}\left(-\frac{3}{2}\right) = -1$ .

## 0.5 EXERCISES

### PRACTICE

In Exercises 1–5, determine the slope of the line through the two given points.

- |                             |                           |
|-----------------------------|---------------------------|
| 1. $(3, 8), (-9, 4)$        | 2. $(8, 14), (10, 64)$    |
| 3. $(-3, -1), (2, 14)$      | 4. $(1.5, 6), (-2.5, -2)$ |
| 5. $(6.5, -3.1), (-2, 3.3)$ |                           |

In Exercises 6–10, determine if the line given contains the specified point.

- |                                   |                              |
|-----------------------------------|------------------------------|
| 6. $2x + 3y = 17$ ; $(2, 3)$      | 7. $y = 6x - 3$ ; $(10, 44)$ |
| 8. $y = -6x - 4$ ; $(8, -52)$     | 9. $y = 23x - 3$ ; $(2, 63)$ |
| 10. $7x - 5y = 20$ ; $(-30, -46)$ |                              |

For each line described in Exercises 11–15, write the equation of the line in the specified form.

11. Passing through  $(-1, 0)$  with slope  $\frac{7}{2}$ ; standard form
12. Passing through  $(4, -1)$  and  $(-2, 3)$ ; standard form
13. Passing through  $(0, 3)$  and  $(-3, 1)$ ; slope-intercept form
14. Passing through  $(5, 2)$  and  $(-3, 6)$ ; point-slope form
15. Passing through  $(-3, 4)$  and  $(2, 2)$ ; standard form

In Exercises 16–21, write each equation in slope-intercept form, if possible. Identify the slope and  $y$ -intercept; then draw the graph.

16.  $x - 2y = 6$

17.  $x + 5y = 10$

18.  $4x - 7 = 0$

19.  $4x + 2y = 11$

20.  $3x + 4y = 8$

21.  $5x - 6y = 12$

In Exercises 22–26, determine if the lines  $\overline{AB}$  and  $\overline{BC}$  are the same line.

22.  $A = (0, 0), B = (3, 8), C = (6, 16)$

23.  $A = (1, -1), B = (3, 2), C = (6, 16)$

24.  $A = (1, 1), B = (2, 4), C = (6, 16)$

25.  $A = (-6, 2), B = (0, 2), C = (5, 8)$

26.  $A = (1, 3), B = (-1, -1), C = (0, 2)$

In Exercises 27–36, determine if the two lines given are parallel, perpendicular, or neither. Explain why.

27.  $y = 4x - 1$  and  $y = 0.25x + 6$

28.  $y = 11x + 4$  and  $y = 11x - 4$

29.  $2x + 3y = 17$  and  $2x + 3y = 0$

30.  $4x + 6y = 4$  and  $3x - 2y = 4$

31.  $45x + 5y = 20$  and  $y = \frac{1}{9}x + 3$

32.  $y = 5x + 7$  and  $10x - 2y = 9$

33.  $3x - y = 12$  and  $-x + 3y = 36$

34.  $y = \frac{1}{2}x + 8$  and  $2x - 4y = 3$

35.  $y = x - 15$  and  $3x + 3y = 15$

36.  $y = 6x - 6$  and  $4x + 24y = 4$

In Exercises 37–42, find an equation for the line satisfying the given conditions.

37. Parallel to  $x + 3y = 4$  and passing through  $(3, 1)$

38. Parallel to  $2x + 3y = 5$  and passing through  $(-2, 4)$

39. Parallel to  $7x - 5y = 2$  and passing through  $(-1, 2)$

40. Perpendicular to  $5x + 2y = 3$  and passing through  $(-4, -1)$

41. Perpendicular to  $3x - 4y = 4$  and passing through  $(3, 3)$

42. Perpendicular to  $x - 6y = 4$  and passing through  $(-2, 7)$

43. Given that the lines  $y = 2x + b_1$  and  $y = -3x + b_2$  intersect at  $(12, 24)$ , find  $b_1$  and  $b_2$  and sketch both of the lines together on the same graph.

### APPLICATIONS

44. Water freezes at  $32^\circ$  Fahrenheit and at  $0^\circ$  Celsius. Water boils at  $212^\circ$  Fahrenheit and at  $100^\circ$  Celsius. Determine a linear relation (equation) for a temperature  $F$  (for Fahrenheit) in terms of the temperature  $C$  (for Celsius).

45. The owner of a gift shop has determined that if the price for a plush toy is \$12, the store will sell 100 plush toys per month. However, only 80 plush toys are sold if the price is raised to \$14. Assuming a linear relationship between  $x$ , the number of plush toys sold, and  $y$ , the price of a plush toy, write an equation relating  $x$  and  $y$ .
46. Suppose a vendor of hot dogs at high school baseball games profits \$100 on the sale of 300 hot dogs and \$130 on the sale of 360 hot dogs. Write a linear equation relating  $x$ , the number of hot dogs sold, and  $y$ , the profit.
47. Suppose a roadside produce stand will sell 250 pounds of tomatoes for \$562.50 and 70 pounds for \$157.50. Assuming a linear relationship between weight and price, how much would 100 pounds cost?
48. A seafood distributor sold large sea scallops for a price of \$325 per gallon last January. Six months later, the price was \$355 per gallon. If there was a linear relationship between the month (where January = 1, February = 2, etc.) and the price during this time period, what was the price in April?
49. The Castle Promotions Company sells 12 dozen magnets with a college logo to college bookstores for \$308, and 15 dozen for \$380. Assuming a linear relationship between cost and quantity, how much would 20 dozen magnets cost?

 **WRITING & THINKING**

50. Sketch the lines  $y = 3x - 4$  and  $y = -3x + 2$  together on the same graph. Draw a horizontal line through their common point. What can be said about this horizontal line?
51. Every line that does not pass through the origin determines a right triangle with the right angle at the origin. The three sides of the triangle lie on part of the line and the two axes (as shown in the graph). Write a formula for the area of this triangle if the line is given by  $y = mx + b$ .

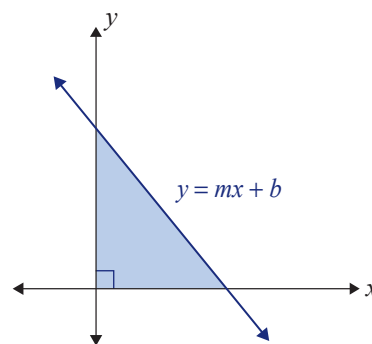

52. Suppose  $(c_1, d_1)$  and  $(c_2, d_2)$  are points on the graph of  $y = mx + b$ . Then  $m = \frac{d_2 - d_1}{c_2 - c_1}$ . Find an expression for  $b$  in terms of the  $c$ 's and  $d$ 's.

The last equation is never true. Therefore, the original equation is a contradiction and has no solution.

$$\begin{array}{ll} \text{c. } 5(x+1) - 6x = -x + 5 & \text{Use the distributive property.} \\ 5x + 5 - 6x = -x + 5 & \text{Simplify.} \\ -x + 5 = -x + 5 & \text{Add } x \text{ to both sides.} \\ 5 = 5 & \end{array}$$

The last equation is always true. Therefore, the original equation is an identity and has an infinite number of solutions. Every real number is a solution.

## 0.6 EXERCISES

### PRACTICE

Solve each equation. See Examples 1 through 4.

1.  $3x + 11 = 2$

2.  $3x + 10 = -5$

3.  $5x - 4 = 6$

4.  $4y - 8 = -12$

5.  $6x + 10 = 22$

6.  $3n + 7 = 19$

7.  $9x - 5 = 13$

8.  $2x - 4 = 12$

9.  $1 - 3y = 4$

10.  $5 - 2x = 9$

11.  $14 + 9t = 5$

12.  $5 + 2x = -7$

13.  $-5x + 2.9 = 3.5$

14.  $3x + 2.7 = -2.7$

15.  $10 + 3x - 4 = 18$

16.  $5 + 5x - 6 = 9$

17.  $15 = 7x + 7 + 8$

18.  $14 = 9x + 5 + 8$

19.  $5y - 3y + 2 = 2$

20.  $6y + 8y - 7 = -7$

21.  $x - 4x + 25 = 31$

22.  $3y + 9y - 13 = 11$

23.  $-20 = 7y - 3y + 4$

24.  $-20 = 5y + y + 16$

25.  $4n - 10n + 35 = 1 - 2$

26.  $-5n - 3n + 2 = 34$

27.  $3n - 15 - n = 1$

28.  $2n + 12 + n = 0$

29.  $5.4x - 0.2x = 0$

30.  $0 = 5.1x + 0.3x$

31.  $\frac{1}{2}x + 7 = \frac{7}{2}$

32.  $\frac{3}{5}x + 4 = \frac{9}{5}$

33.  $\frac{1}{2} - \frac{8}{3}x = \frac{5}{6}$
34.  $\frac{2}{5} - \frac{1}{2}x = \frac{7}{4}$
35.  $\frac{3}{2} = \frac{1}{3}x + \frac{11}{3}$
36.  $\frac{11}{8} = \frac{1}{5}x + \frac{4}{5}$
37.  $\frac{7}{2} - 5 - \frac{5}{2}x = 9$
38.  $\frac{8}{3} + 2 - \frac{7}{3}x = 6$
39.  $\frac{5}{8}x - \frac{1}{4}x + \frac{1}{2} = \frac{3}{10}$
40.  $\frac{1}{2}x + \frac{3}{4}x - \frac{5}{3} = \frac{5}{6}$
41.  $\frac{y}{2} + \frac{1}{5} = 3$
42.  $\frac{y}{3} - \frac{2}{3} = 7$
43.  $\frac{7}{8} = \frac{3}{4}x - \frac{5}{8}$
44.  $\frac{1}{10} = \frac{4}{5}x + \frac{3}{10}$
45.  $\frac{y}{7} + \frac{y}{28} + \frac{1}{2} = \frac{3}{4}$
46.  $\frac{5y}{6} - \frac{7y}{8} - \frac{1}{12} = \frac{1}{3}$
47.  $x + 1.2x + 6.9 = -3.0$
48.  $3x - 0.75x - 1.72 = 3.23$
49.  $10 = x - 0.5x + 32$
50.  $33 = y + 3 - 0.4y$
51.  $2.5x + 0.5x - 3.5 = 2.5$
52.  $4.7 - 0.5x - 0.3x = -0.1$
53.  $6.4 + 1.2x + 0.3x = 0.4$
54.  $5.2 - 1.3x - 1.5x = -0.4$
55.  $-12.13 = 2.42y + 0.6y - 13.64$
56.  $-7.01 = 1.75x + 3.05x - 8.45$
57.  $-0.4x + x + 17.2 = 18.1$
58.  $y - 0.75y + 13.76 = 14.66$
59.  $0 = 17.3x - 15.02x - 0.456$
60.  $0 = 20.5x - 16.35x + 0.1245$
61.  $3x + 2 = x - 8$
62.  $5x + 1 = 2x - 5$
63.  $4n - 3 = n + 6$
64.  $6y + 3 = y - 7$
65.  $3y + 18 = 7y - 6$
66.  $2y + 5 = 8y + 10$
67.  $3x + 11 = 8x - 4$
68.  $9x + 3 = 5x - 9$
69.  $14n = 3n$
70.  $1.6x = 0.8x$
71.  $6y - 2.1 = y - 2.1$
72.  $13x + 5 = 2x + 5$
73.  $2(z + 1) = 3z + 3$
74.  $6x - 3 = 3(x + 2)$
75.  $16y + 23y - 3 = 16y - 2y + 2$
76.  $5x - 2x + 4 = 3x + x - 1$
77.  $0.25 + 3x + 6.5 = 0.75x$
78.  $0.9y + 3 = 0.4y + 1.5$
79.  $6.5 + 1.2x = 0.5 - 0.3x$
80.  $x - 0.1x + 0.8 = 0.2x + 0.1$

81.  $\frac{2}{3}x + 1 = \frac{1}{3}x - 6$

83.  $\frac{y}{5} + \frac{3}{4} = \frac{y}{2} + \frac{3}{4}$

85.  $\frac{3}{8}\left(y - \frac{1}{2}\right) = \frac{1}{8}\left(y + \frac{1}{2}\right)$

87.  $\frac{2x}{3} + \frac{x}{3} = -\frac{3}{4} + \frac{x}{2}$

89.  $x + \frac{2}{3}x - 2x = \frac{x}{6} - \frac{1}{8}$

91.  $3(1 + 9x) = 6(2 - 4x)$

93.  $3(4x - 1) = 4(2x - 3) + 8$

95.  $5 - 3(2x + 1) = 4(x - 5) + 6$

97.  $8 + 4(2x - 3) = 5 - (x + 3)$

99.  $4.7 - 0.3x = 0.5x - 0.1$

101.  $0.2(x + 3) = 0.1(x - 5)$

103.  $\frac{1}{2}(4 - 8x) = \frac{1}{3}(4x + 7) - 3$

105.  $0.6x - 22.9 = 1.5x - 18.4$

107.  $0.12n + 0.25n - 5.895 = 4.3n$

109.  $0.7(x + 14.1) = 0.3(x + 32.9)$

82.  $\frac{4}{5}n + 2 = \frac{2}{5}n - 4$

84.  $\frac{5n}{6} + \frac{1}{9} = \frac{3n}{2} + \frac{1}{9}$

86.  $\frac{1}{2}\left(\frac{x}{2} + 1\right) = \frac{1}{3}\left(\frac{x}{2} - 1\right)$

88.  $\frac{3}{4}x + \frac{1}{5}x = \frac{1}{2}x - \frac{3}{10}$

90.  $3x + \frac{1}{2}x - \frac{2}{5}x = \frac{x}{10} + \frac{7}{20}$

92.  $4(5 - x) = 8(3x + 10)$

94.  $7(2x - 1) = 5(x + 6) - 13$

96.  $-2(y + 5) - 4 = 6(y - 2) + 2$

98.  $8(3x + 5) - 9 = 9(x - 2) + 14$

100.  $5.8 - 0.1x = 0.2x - 0.2$

102.  $0.4(x + 3) = 0.3(x - 6)$

104.  $3 + \frac{1}{4}(x - 4) = \frac{2}{5}(2 + 3x)$

106.  $0.1y + 3.8 = 5.72 - 0.3y$

108.  $0.15n + 32n - 21.0005 = 10.5n$

110.  $0.8(x - 6.21) = 0.2(x - 24.84)$

Determine whether each equation is a conditional equation, an identity, or a contradiction. See Example 5.

111.  $2(3x - 1) + 5 = 3$

112.  $-2x + 13 = -2(x - 7)$

113.  $5x + 13 = -2(x - 7) + 3$

114.  $3x + 9 = -3(x - 3) + 6x$

115.  $7(x - 1) = -3(3 - x) + 4x$

116.  $3(x - 2) + 4x = 6(x - 1) + x$

117.  $5(x + 1) = 3(x + 1) + 2(x + 1)$

118.  $8x - 20 + x = -3(5 - 2x) + 3(x - 4)$

119.  $2x + 3x = 5.2(3 - x)$

120.  $5.2x + 3.4x = 0.2(x - 0.42)$

 **WRITING & THINKING**

**121.** Find the error(s) made in solving each equation and give the correct solution.

**a.**  $\frac{1}{3}x + 4 = 9$

$$3 \cdot \frac{1}{3}x + 4 = 3 \cdot 9$$

$$x + 4 = 27$$

$$x + 4 - 4 = 27 - 4$$

$$x = 23$$

**b.**  $5x + 3 = 11$

$$(5x - 3) + (3 - 3) = 11 - 3$$

$$2x + 0 = 8$$

$$\frac{2x}{2} = \frac{8}{2}$$

$$x = 4$$

**122.** Answer each question.

**a.** Simplify the expression  $3(x + 5) + 2(x - 7)$ .

**b.** Solve the equation  $3(x + 5) + 2(x - 7) = 31$ .

**c.** How are the methods you used to answer parts **a.** and **b.** similar? How are they different?

**123.** Write an equation to represent each situation, using  $x$  to represent Ryan's current age. Determine whether each equation is a conditional equation, an identity, or a contradiction, and explain why that makes sense for the situation represented.

**a.** In 6 years, Ryan will be 20 years old.

**b.** In 6 years, Ryan will be 8 years older than he is now.

**c.** In 6 years, Ryan will be 3 years older than he will be 3 years from now.

## 0.7 EXERCISES

 PRACTICE

Solve the following quadratic equations by factoring. See Example 1.

1.  $2x^2 - x = 3$

2.  $3x^2 - 7x = 0$

3.  $x^2 - 14x + 49 = 0$

4.  $9x - 5x^2 = -2$

5.  $y(2y + 9) = -9$

6.  $2x^2 - 3x = x^2 + 18$

7.  $(3x + 2)(x - 1) = 7 - 7x$

8.  $3x^2 + 33 = 2x^2 + 14x$

9.  $5x^2 + 2x + 3 = 4x^2 + 6x - 1$

10.  $15x^2 + x = 2$

11.  $(x - 7)^2 = 16$

12.  $4x^2 - 9 = 0$

Solve the following quadratic equations by taking square roots. See Example 2.

13.  $(x - 3)^2 = 9$

14.  $(8t - 3)^2 = 0$

15.  $(2x + 1)^2 - 7 = 0$

16.  $(y - 18)^2 - 1 = 0$

17.  $9 = (3s + 2)^2$

18.  $(2x - 1)^2 = 8$

19.  $x^2 - 4x + 4 = 49$

20.  $-3(n + 7)^2 = -27$

21.  $(3x - 6)^2 = 4x^2$

Solve the following quadratic equations by completing the square. See Example 3.

22.  $x^2 + 8x + 7 = -8$

23.  $2x^2 + 6x - 10 = 10$

24.  $2x^2 + 7x - 15 = 0$

25.  $4x^2 - 4x - 63 = 0$

26.  $u^2 + 10u + 9 = 0$

27.  $4x^2 - 56x + 195 = 0$

28.  $4x^2 + 32x - 260 = 0$

29.  $z^2 + 26z + 2 = -23$

30.  $y^2 + 22y + 96 = 0$

Solve the following quadratic equations using the quadratic formula. See Example 4.

31.  $3x^2 - 4 = -x$

32.  $2.1y^2 - 3.5y = 4$

33.  $a(a + 2) = -1$

34.  $3x^2 - 2x = 0$

35.  $6x^2 + 5x - 4 = 3x - 2$

36.  $7x^2 - 4x = 51$

37.  $4x^2 - 14x - 27 = 3$

Solve the following quadratic equations using any appropriate method.

38.  $(z - 11)^2 = 9$

39.  $x^2 + 20x + 36 = -48$

40.  $256t^2 - 324 = 0$

41.  $(y - 8)^2 = 36$

42.  $(9y - 6)^2 = 121y^2$

43.  $2x^2 + 8x - 3 = 6x$

44.  $x^2 - 6x = 27$

45.  $3a^2 + 12a - 576 = 0$

46.  $-3(b + 5)^2 = -768$

47.  $y^2 + 13y + 42 = 0$

48.  $3x^2 - 6x = 0$

49.  $7x^2 - 42x = 0$

50.  $y^2 + 24y + 23 = 0$

51.  $5x^2 - 5x - 10 = 0$

52.  $4w^2 + 10w + 5 = 3w^2 + 18w - 10$

53.  $|x^2 - 3x| = 2$  (**Hint:** Replace  $|x^2 - 3x|$  first with  $x^2 - 3x$  and solve the resulting equation, then replace it with  $-(x^2 - 3x)$  and solve the resulting equation.)

54.  $|x^2 - 8| = 1$

 **WRITING & THINKING**

55. Factor the quadratic  $9x^2 - 6x - 4$ .

56. Factor the quadratic  $4x^2 + 12x + 1$ .

57. Determine  $b$  and  $c$  so that the equation  $x^2 + bx + c = 0$  has the solution set  $\{-3, 8\}$ .

 **TECHNOLOGY**

Use a graphing calculator to solve the following quadratic equations.

58.  $5x^2 - 3x = 17$

59.  $(a + 4)(4a - 3) = 5$

60.  $10\pi r + \pi r^2 = 107$

61.  $4.8x^2 + 3.5x - 9.2 = 0$

### Example 4: Equations with Positive Rational Exponents

Solve the following equations with rational exponents.

a.  $x^{\frac{3}{4}} - 8 = 0$

#### Solution

$$x^{\frac{3}{4}} - 8 = 0$$

$$x^{\frac{3}{4}} = 8$$

$$\sqrt[4]{x^3} = 8$$

$$x^3 = 8^4$$

$$x = 8^{\frac{4}{3}}$$

$$x = \left(8^{\frac{1}{3}}\right)^4$$

$$x = (2)^4$$

$$x = 16$$

Since the term containing the rational exponent can be rewritten as a radical expression, we will begin by isolating that term.

Raising both sides to the fourth power eliminates the fourth root.

Raising both sides to the  $\frac{1}{3}$  power solves the equation for  $x$ , but we can evaluate the expression on the right-hand side.

Verify that this number solves the original equation.

b.  $(18x^2 - 54x - 8)^{\frac{1}{6}} = 2$

#### Solution

$$(18x^2 - 54x - 8)^{\frac{1}{6}} = 2$$

$$\sqrt[6]{18x^2 - 54x - 8} = 2$$

$$18x^2 - 54x - 8 = 2^6$$

$$18x^2 - 54x - 8 = 64$$

$$18x^2 - 54x - 72 = 0$$

$$18(x^2 - 3x - 4) = 0$$

$$x^2 - 3x - 4 = 0$$

$$(x - 4)(x + 1) = 0$$

$$x = 4, -1$$

The exponent of  $\frac{1}{6}$  indicates we should raise both sides to the sixth power in order to eliminate the radical.

We are left with a second-degree polynomial equation that can be solved by factoring.

Note that both solutions solve the original equation.

## 0.8 EXERCISES



### PRACTICE

State any restrictions on  $x$ , and then solve the proportions. See Example 1.

1.  $\frac{4x}{7} = \frac{x+5}{3}$

2.  $\frac{3x+1}{4} = \frac{2x+1}{3}$

3.  $\frac{10}{x} = \frac{5}{x-2}$

4.  $\frac{8}{x-3} = \frac{12}{2x-3}$

5. 
$$\frac{4}{x-4} = \frac{2}{x+3}$$

7. 
$$\frac{x+2}{5x} = \frac{x-6}{3x}$$

9. 
$$\frac{5x+2}{x-6} = \frac{11}{4}$$

6. 
$$\frac{3}{x+5} = \frac{6}{x-2}$$

8. 
$$\frac{x-4}{3x} = \frac{x-2}{5x}$$

10. 
$$\frac{x+9}{3x+2} = \frac{5}{8}$$

State any restrictions on  $x$ , and then solve the equations. See Example 2.

11. 
$$\frac{5x}{4} - \frac{1}{2} = -\frac{3}{16}$$

13. 
$$\frac{3x-1}{6} - \frac{x+3}{4} = \frac{7}{12}$$

15. 
$$\frac{2+x}{4} - \frac{5x-2}{12} = \frac{8-2x}{5}$$

17. 
$$\frac{2}{3x} = \frac{1}{4} - \frac{1}{6x}$$

19. 
$$\frac{3}{5x} - \frac{1}{5} = \frac{3}{4x}$$

21. 
$$\frac{3}{4x} - \frac{1}{2} = \frac{7}{8x} + \frac{1}{6}$$

23. 
$$\frac{2}{4x+1} = \frac{4}{x^2+9x}$$

25. 
$$\frac{9}{x^2-6x} = \frac{5}{2x-3}$$

27. 
$$\frac{x}{x-4} - \frac{4}{2x-1} = 1$$

29. 
$$\frac{x+2}{x+1} + \frac{x+2}{x+4} = 2$$

31. 
$$\frac{2}{4x-1} + \frac{1}{x+1} = \frac{3}{x+1}$$

33. 
$$\frac{x-2}{x-3} + \frac{x-3}{x-2} = \frac{2x^2}{x^2-5x+6}$$

35. 
$$\frac{3x+5}{3x+2} + \frac{8x+16}{3x^2-4x-4} = \frac{x+2}{x-2}$$

37. 
$$\frac{3}{3x-1} + \frac{1}{x+1} = \frac{4}{2x-1}$$

12. 
$$\frac{x}{6} - \frac{1}{42} = \frac{1}{7}$$

14. 
$$\frac{x-2}{3} - \frac{x-3}{5} = \frac{13}{15}$$

16. 
$$\frac{4x+1}{5} = \frac{2x+3}{2} - \frac{x+2}{4}$$

18. 
$$\frac{1}{x} - \frac{8}{21} = \frac{3}{7x}$$

20. 
$$\frac{3}{8x} - \frac{7}{10} = \frac{1}{5x}$$

22. 
$$\frac{5}{3x} + \frac{1}{2} = \frac{7}{9x} - \frac{5}{6}$$

24. 
$$\frac{3}{4x-1} = \frac{4}{x^2+x}$$

26. 
$$\frac{-9}{x^2+5x} = \frac{8}{4-9x}$$

28. 
$$\frac{x}{x+3} + \frac{1}{x+2} = 1$$

30. 
$$\frac{3x-2}{x+4} + \frac{2x+5}{x-1} = 5$$

32. 
$$\frac{x-2}{x+4} - \frac{3}{2x+1} = \frac{x-7}{x+4}$$

34. 
$$\frac{x}{x-4} - \frac{12x}{x^2+x-20} = \frac{x-1}{x+5}$$

36. 
$$\frac{3x+5}{3x+2} - \frac{4-2x}{3x^2+8x+4} = \frac{x+4}{x+2}$$

38. 
$$\frac{2}{x+1} + \frac{4}{2x-3} = \frac{4}{x-5}$$

Solve the following radical equations. See Example 3.

39.  $\sqrt{4-x} - x = 2$

40.  $\sqrt{x^2 - 4x + 5} - x + 2 = 0$

41.  $\sqrt{x^2 - 4x + 4} + 2 = 3x$

42.  $\sqrt{50 + 7s} - s = 8$

43.  $\sqrt[4]{2x+3} = -1$

44.  $\sqrt{11x+3} + 4x = 18$

45.  $\sqrt{x+10} + 1 = x - 1$

46.  $\sqrt{x+1} + 10 = x - 1$

47.  $\sqrt{x^2 - 10} - 1 = x + 1$

48.  $\sqrt[3]{5x^2 - 14x} = -2$

49.  $\sqrt{4z+41} + 3 = z + 2$

50.  $\sqrt[3]{3-2x} - \sqrt[3]{x+1} = 0$

51.  $\sqrt[4]{x^2 - x} = \sqrt[4]{x-1}$

52.  $\sqrt[5]{7t^2 + 2t} = \sqrt[5]{5t^2 + 4}$

53.  $\sqrt[3]{y^3 - 7y + 2} = \sqrt[3]{2 - 3y}$

54.  $\sqrt{3y+4} + \sqrt{5y+6} = 2$

55.  $\sqrt{3-3x} - 3 = \sqrt{3x+2}$

56.  $\sqrt{2b-1} + 3 = \sqrt{10b-6}$

57.  $\sqrt{5x+5} = \sqrt{4x-7} + 2$

58.  $\sqrt{14y^2 - 18y + 4} + 2 = 2y$

59.  $\sqrt{9x+4} = \sqrt{7x+1} + 1$

Solve the following equations. See Example 4.

60.  $(x+3)^{\frac{1}{4}} + 2 = 0$

61.  $(2x-5)^{\frac{1}{4}} = (x-1)^{\frac{1}{4}}$

62.  $(2x-1)^{\frac{2}{3}} = x^{\frac{1}{3}}$

63.  $(3y^2 + 9y - 5)^{\frac{1}{2}} = y + 3$

64.  $(3x-5)^{\frac{1}{5}} = (x+1)^{\frac{1}{5}}$

65.  $w^{\frac{3}{5}} + 8 = 0$

66.  $z^{\frac{4}{3}} - \frac{16}{81} = 0$

67.  $x^{\frac{2}{3}} - \frac{25}{49} = 0$

68.  $(x-2)^{\frac{2}{3}} = (14-x)^{\frac{1}{3}}$

69.  $(y-2)^{\frac{2}{3}} = (13y-66)^{\frac{1}{3}}$

70.  $(x^2 + 21)^{\frac{-3}{2}} = \frac{1}{125}$

71.  $(x^2 + 7)^{\frac{-3}{2}} = \frac{1}{64}$

### APPLICATIONS

72. **Computers:** Making a statistical analysis, Ana found 3 defective computers in a sample of 20 computers. If this ratio is consistent, how many defective computers does she expect to find in a batch of 2400 computers?

73. **Manufacturing:** At the Bright-As-Day light bulb plant, 3 out of each 100 bulbs produced are defective. If the daily production is 4800 bulbs, how many are defective?

74. **Education:** The University of Arizona has a ratio of 1 professor for every 23 students. If there are 1600 faculty members at the university, how many students are enrolled there?

75. **Baseball:** New York Yankees player Didi Gregorius has a recorded batting average of 15 hits for every 50 times at bat. If he maintains this average, how many at bats will he need to achieve 111 hits? (Round to the nearest whole number.)
76. **Cartography:** On a map of Maryland, one inch represents 4 miles. If there are 8.5 inches between Baltimore, MD and Washington, DC, how far are the two cities from each other?
77. **Architecture:** A floor plan is drawn to scale in which 1 inch represents 4 feet. What size will the drawing be for a room that is 30 feet by 40 feet? (**Hint:** Set up two proportions.)
78. **Baking:** The recipe for Nestle Tollhouse Chocolate Chip Cookies calls for 2 cups of chocolate chips to make 5 dozen cookies. If you want to bake 17 dozen cookies, how many cups of chocolate chips do you need?
79. **Car maintenance:** In the instructions for Never-Ice Antifreeze it states that 4 quarts of antifreeze are needed for every 10 quarts of radiator capacity. If Sal's car has a 22-quart radiator, how many quarts of antifreeze will it need?
80. **Landscape architecture:** An architect is to draw plans for a city park. He intends to use a scale of  $\frac{1}{2}$  inch to represent 25 feet. How many inches will be needed to use for the length and width of a rectangular playing field that is 50 yards by 125 yards? (1 yard = 3 feet)
81. **Testing cars:** A test driver wants to increase the speed of the car he is driving by 3 miles per hour every 2 seconds. But he can only check his speed every 5 seconds because he is busy with other items during the test drive.
- By how much should he increase his speed in 5 seconds?
  - If he starts checking his speed at 40 miles per hour, how fast should he be going after 10 seconds?
82. **Decorating:** Jack and Diane are decorating a nursery room for their baby, which will be born in a few months. In one hour, Jack can get  $\frac{1}{6}$  of the nursery done and Diane can get  $\frac{1}{12}$  of the nursery done. If they work together, they can get  $\frac{1}{x}$  of the nursery done in one hour. Determine how many hours it will take Jack and Diane to decorate the nursery if they work together by solving the equation  $\frac{1}{6} + \frac{1}{12} = \frac{1}{x}$  for  $x$ .
83. **Printing:** A local print shop has a big order of pamphlets to print, so they decide to use two of their printers for the one job. The newer printer can print the pamphlets four times as fast as the older printer. That means in one hour, the newer printer can complete  $\frac{1}{x}$  of the print job and the older printer can complete  $\frac{1}{4x}$  of the print job. Working together, the printers can complete the job in 4 hours. Determine how many hours it would take the newer printer to print all of the pamphlets by itself by solving the equation  $\frac{1}{x} + \frac{1}{4x} = \frac{1}{4}$  for  $x$ .

**84. Construction:** Two groups of civil engineers are surveying an area to prepare for the construction of a shopping center. The first group is full of new college graduates and it will take them four more hours than it takes the second group, which is full of seasoned professionals. The second group can complete the job in  $x$  hours. This means that in one hour, the first group can complete  $\frac{1}{x+4}$  of the job and the second group can complete  $\frac{1}{x}$  of the job. Working together, they can complete the surveying job in  $\frac{15}{4}$  hours. Determine how many hours it would take each team to complete the job individually by solving the equation  $\frac{1}{x+4} + \frac{1}{x} = \frac{4}{15}$  for  $x$ .

**85. Running:** Terrence and Alicia are competing in a marathon where the average running speed is  $x$  kilometers per hour. Terrence is running 2 kilometers per hour slower than the average running speed. Alicia is running 2 kilometers per hour faster than the average running speed. After a certain amount of time, Terrence ran 4 kilometers and Alicia ran 6 kilometers.

- Determine the speed of the average runner by solving the equation  $\frac{4}{x-2} = \frac{6}{x+2}$  for  $x$ .
- What was Terrence's average running speed?
- What was Alicia's average running speed?
- How long did it take Terrence to run 4 kilometers and Alicia to run 6 kilometers?



### WRITING & THINKING

In simplifying rational expressions, the result is a rational or polynomial expression. However, in solving equations with rational expressions, the goal is to find a value (or values) for the variable that will make the equation a true statement. Many students confuse these two ideas. To avoid confusing the techniques for adding and subtracting rational expressions with the techniques for solving equations, simplify the expression in part **a.** and solve the equation in part **b.** Explain, in your own words, the differences in your procedures. Assume no denominator has a value of 0.

**86. a.**  $\frac{10}{x} + \frac{31}{x-1} + \frac{4x}{x-1}$

**b.**  $\frac{10}{x} + \frac{31}{x-1} = \frac{4x}{x-1}$

**88. a.**  $\frac{3x}{x^2-4} + \frac{5}{x+2} + \frac{2}{x-2}$

**b.**  $\frac{3x}{x^2-4} + \frac{5}{x+2} = \frac{2}{x-2}$

**90. a.**  $\frac{2}{x+9} - \frac{2}{x-9} + \frac{1}{2}$

**b.**  $\frac{2}{x+9} - \frac{2}{x-9} = \frac{1}{2}$

**87. a.**  $\frac{-4}{x^2-16} + \frac{x}{2x+8} - \frac{1}{4}$

**b.**  $\frac{-4}{x^2-16} + \frac{x}{2x+8} = \frac{1}{4}$

**89. a.**  $\frac{7}{5x} + \frac{2}{x-4} - \frac{3}{5x}$

**b.**  $\frac{7}{5x} + \frac{2}{x-4} = \frac{3}{5x}$

## 1.1 EXERCISES

 PRACTICE

In Exercises 1–9, evaluate the given function for parts **a.**–**d.**

1.  $f(x) = 2x - 7$

a.  $f(5)$

b.  $f(-2)$

c.  $f(a + 1)$

d.  $f(a) + 1$

2.  $f(x) = 3x + 5$

a.  $f(2)$

b.  $f(-1)$

c.  $f(a + 1)$

d.  $f(a) + 1$

3.  $f(x) = x^2 - 2x + 1$

a.  $f(-2)$

b.  $f(3)$

c.  $f(a + 1)$

d.  $f(a) + 1$

4.  $f(x) = 3x^2 - x + 2$

a.  $f(-3)$

b.  $f(2)$

c.  $f(a + 1)$

d.  $f(a) + 1$

5.  $f(x) = x^3 + x^2 - 3x + 1$

a.  $f(-1)$

b.  $f(-3)$

c.  $f(a + 1)$

d.  $f(a) + 1$

6.  $f(x) = 2x^3 - 4x^2 + x - 6$

a.  $f(-2)$

b.  $f(4)$

c.  $f(a + 1)$

d.  $f(a) + 1$

7.  $f(x) = 4x^2 - 1$

a.  $f(3)$

b.  $f(a + 2)$

c.  $f(x + h)$

d.  $f(-2) - f(-1)$

8.  $f(x) = 2 - 3x^2$

a.  $f(5)$

b.  $f(a - 3)$

c.  $f(x + h)$

d.  $f(3) - f(2)$

9.  $f(x) = \sqrt{x+5}$

a.  $f(-1)$

b.  $f(a + 2)$ , where  $a \geq -7$

c.  $f(x + h)$

d.  $f(4) - f(1)$

10. Let  $f(x) = \sqrt{x^2 + 1}$ . Find **a.**  $f(\sqrt{3})$ , and **b.**  $f(a + 1)$ .

11. Let  $f(x) = \begin{cases} x - 4 & \text{if } x \leq 2 \\ x^2 - 6 & \text{if } x > 2 \end{cases}$ . Find **a.**  $f(-1)$ , **b.**  $f(2)$ , **c.**  $f(2.5)$ , and **d.**  $f(3)$ .

12. Let  $f(x) = \begin{cases} x^2 & \text{if } x < 0 \\ 3x - 2 & \text{if } x \geq 0 \end{cases}$ . Find **a.**  $f(0)$ , **b.**  $f(-2)$ , **c.**  $f(1.5)$ , and **d.**  $f(3)$ .

In Exercises 13–27, find  $f(x + h) - f(x)$ .

13.  $f(x) = 3x - 1$

14.  $f(x) = 5x - 2$

15.  $f(x) = x^2 + 4$

16.  $f(x) = x^2 - 3$

17.  $f(x) = 2x^2 + 1$

18.  $f(x) = 5 + 3x^2$

19.  $f(x) = x^2 - x$

20.  $f(x) = x^2 + 2x$

21.  $f(x) = 3x - x^2$

22.  $f(x) = 4x^2 - x$

23.  $f(x) = 2x^2 - 3x$

24.  $f(x) = x^3$

25.  $f(x) = x^3 - 1$

26.  $f(x) = x^3 + 7$

27.  $f(x) = x^3 + 5$

In Exercises 28–39, determine the domain of each function.

28.  $f(x) = \frac{3x+1}{(x-5)(x-6)}$

29.  $f(x) = \sqrt{2x+10}$

30.  $f(x) = \sqrt{x^2 + 2}$

31.  $f(x) = \frac{5}{\sqrt{x+10}}$

32.  $f(x) = \frac{2x}{x-2}$

33.  $f(x) = \frac{x-3}{x+1}$

34.  $f(x) = \frac{4}{x^2 - x - 12}$

35.  $f(x) = x - 3$

36.  $f(x) = 4 - 3x$

37.  $f(x) = \frac{1}{\sqrt{2x+5}}$

38.  $f(x) = \begin{cases} 3x+1 & \text{if } 0 \leq x < 4 \\ 5x-2 & \text{if } x \geq 4 \end{cases}$

39.  $f(x) = \begin{cases} 2-x^2 & \text{if } x \leq 2 \\ x-4 & \text{if } x > 2 \end{cases}$

In Exercises 40–51, use the vertical line test to determine whether or not each graph represents a function.

40.

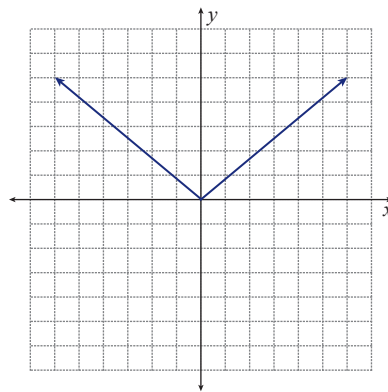

41.

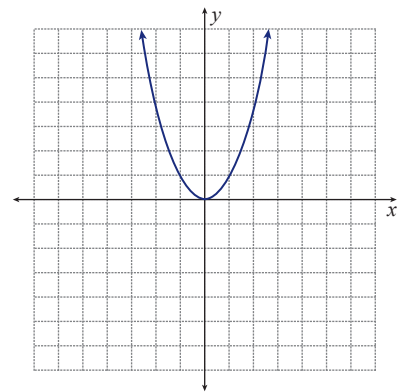

42.

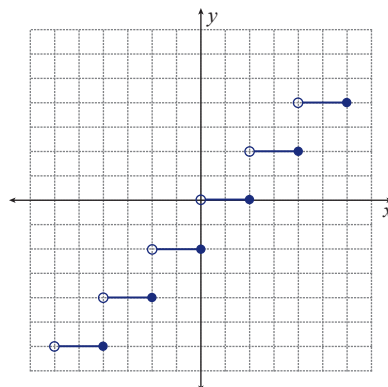

43.

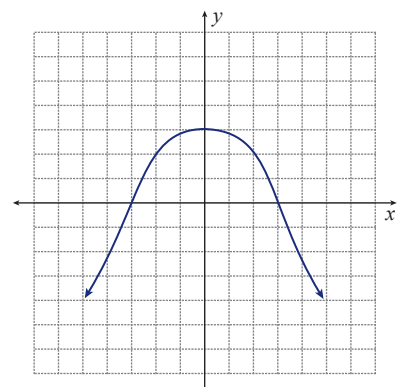

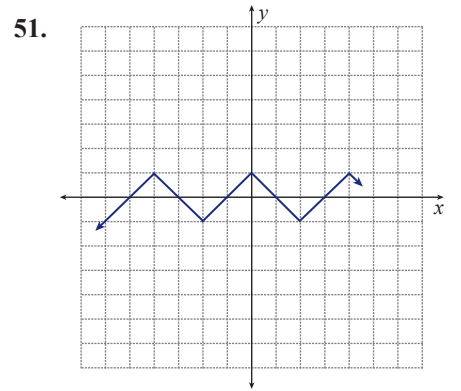
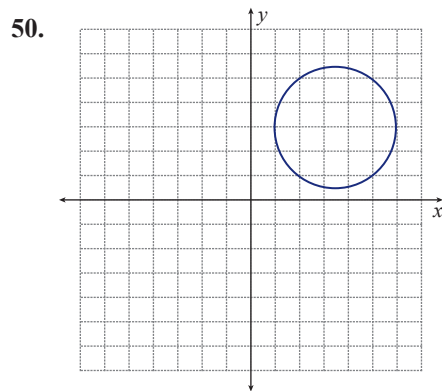
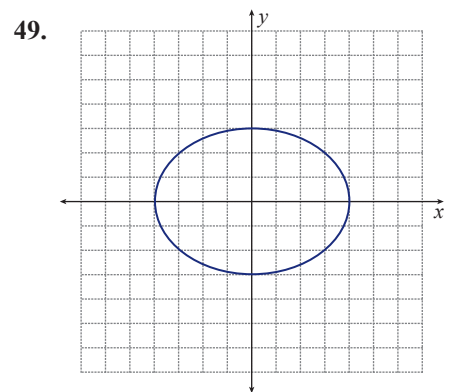
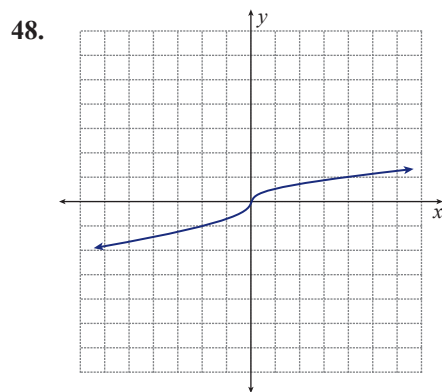
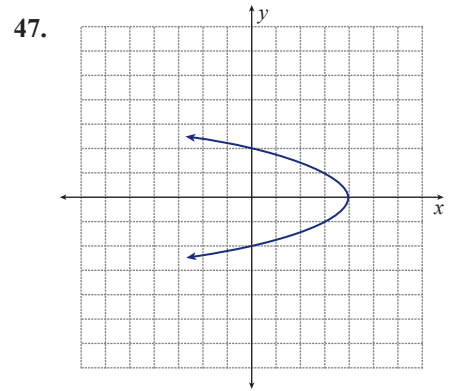
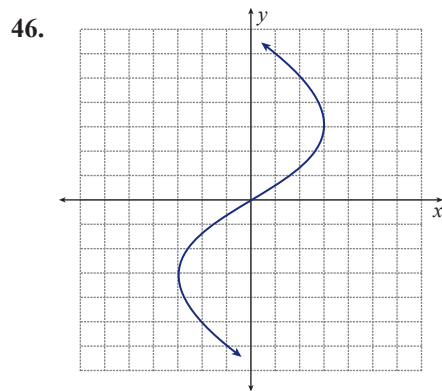
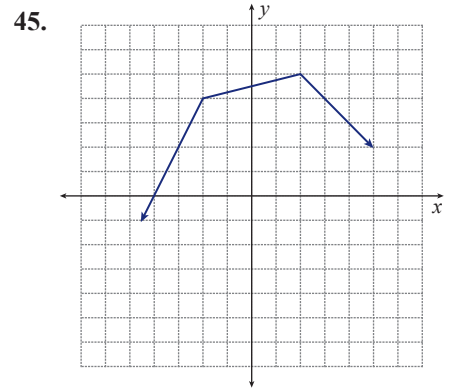
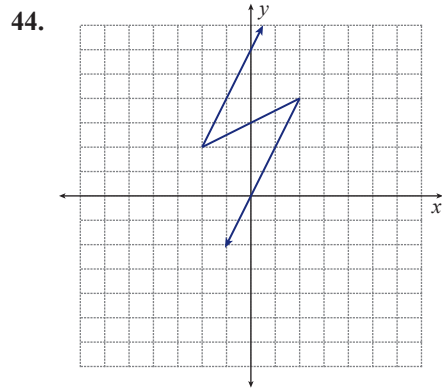

$$\text{c. } m = \frac{\Delta y}{\Delta x} = \frac{f(a+h) - f(a)}{h} = \frac{-2ah - h^2}{h} = \frac{h(-2a-h)}{h} = -2a-h$$

The difference quotient is the slope of the line containing the two points in part b.

## 1.2 EXERCISES

### PRACTICE

- Let  $f(x) = \frac{2x+1}{x^2}$ . Find **a.**  $f(1)$ , **b.**  $f(3)$ , **c.**  $f(3) - f(1)$ , **d.**  $\frac{f(3) - f(1)}{3-1}$ , and **e.** interpret the meaning in parts a.–d.
- Let  $f(x) = \frac{x^2 - 4}{x+3}$ . Find **a.**  $f(0)$ , **b.**  $f(2)$ , **c.**  $f(2) - f(0)$ , **d.**  $\frac{f(2) - f(0)}{2-0}$ , and **e.** interpret the result of part c.

In Exercises 3–23, let  $f(x) = \frac{1}{x}$ ,  $g(x) = x^2 - 2x$ , and  $h(x) = \sqrt{x}$ . Find and simplify each of the following expressions.

- |                      |                           |                                      |
|----------------------|---------------------------|--------------------------------------|
| 3. $f(x) + g(x)$     | 4. $f(x) - g(x)$          | 5. $f(x) \cdot h(x)$                 |
| 6. $g(x) \cdot h(x)$ | 7. $\frac{h(x)}{f(x)}$    | 8. $\frac{g(x)}{h(x)}$               |
| 9. $f(g(1))$         | 10. $g(f(2))$             | 11. $h(g(3))$                        |
| 12. $g(h(2))$        | 13. $f(h(3))$             | 14. $h(f(4))$                        |
| 15. $g(t+1)$         | 16. $f(t-3)$ , $t \neq 3$ | 17. $h(2t-1)$ , $t \geq \frac{1}{2}$ |
| 18. $f(g(t))$        | 19. $g(f(x))$             | 20. $f(h(x))$                        |
| 21. $g(h(x))$        | 22. $h(g(u))$             | 23. $h(f(u))$                        |

In Exercises 24–29, identify two functions  $h(x)$  and  $g(x)$  so that the given function  $f(x)$  can be expressed as  $f(x) = g(h(x))$ . Answers may vary.

- |                               |  |
|-------------------------------|--|
| 24. $f(x) = -\frac{5}{x+4}$   | 25. $f(x) = \sqrt[3]{1-6x^2}$                |
| 26. $f(x) =  2-7x $           | 27. $f(x) = (x^4 + 2)^{\frac{1}{3}}$         |
| 28. $f(x) = (2x^2 + 3x)^{-3}$ | 29. $f(x) = \frac{\sqrt{x-3}}{x^2 - 6x + 9}$ |

## Example 9: Perimeter

A rectangular lot is fenced on three sides. An adjacent building forms the fourth side (see diagram). If the total length of the fencing is 48 feet, write a function that represents the area of the rectangle. Determine a good viewing rectangle and graph the function.

## Solution

Let  $x$  = width of the rectangle. Since the total length of the fence is 48 feet and two sides are each of length  $x$ , then the length of the third side must be  $48 - 2x$ . Since the enclosed area is the product of length times width, we have

$$A(x) = x(48 - 2x).$$

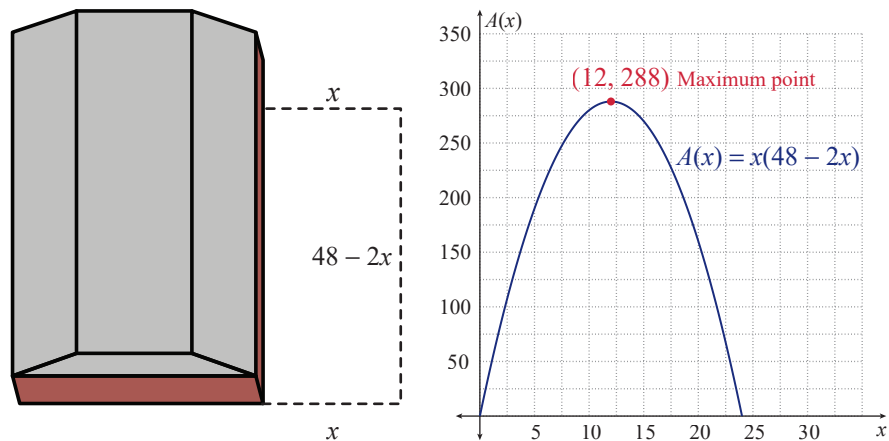

The significance of the highest point (at  $x = 12$ ) is that when the width is 12, the maximum area is enclosed ( $288 \text{ ft}^2$ ). Any other dimensions for the fence reduce total enclosed area.

## 1.3 EXERCISES

 PRACTICE

Find the break-even point given the revenue and cost functions in Exercises 1–4.

1.  $R(x) = 15x$   
 $C(x) = 5x + 30$

2.  $R(x) = 27x$   
 $C(x) = 14x + 442$

3.  $R(x) = 24x - 0.2x^2$   
 $C(x) = 8x + 300$

4.  $R(x) = 9x - 0.7x^2$   
 $C(x) = 2x + 11.2$

Find the equilibrium point given the supply and demand functions in Exercises 5–8.

$$\begin{aligned} 5. \quad S(x) &= 2x + 3 \\ D(x) &= 15 - x \end{aligned}$$

$$\begin{aligned} 6. \quad S(x) &= 4x + 7 \\ D(x) &= 33 - 1.2x \end{aligned}$$

$$\begin{aligned} 7. \quad S(x) &= x^2 + x \\ D(x) &= 35 - x \end{aligned}$$

$$\begin{aligned} 8. \quad S(x) &= x^2 + 3 \\ D(x) &= 51 - 2x \end{aligned}$$

In Exercises 9–18, the quantity represented by  $y$  is related to the quantity represented by  $x$  in one of the following ways:

- (a)  $y$  is directly proportional to  $x$
- (b)  $y$  is inversely proportional to  $x$
- (c)  $y$  is directly proportional to the square of  $x$
- (d)  $y$  is inversely proportional to the square of  $x$
- (e) other

Match the given formula to the best choice of (a) through (e).

$$9. \quad y = 32x$$

$$10. \quad y = \frac{32}{x}$$

$$11. \quad y = 16x^2$$

$$12. \quad y = \frac{-32}{x^2}$$

$$13. \quad y = -x$$

$$14. \quad y = 2x + 3$$

$$15. \quad y = \pi x$$

$$16. \quad y = (x - 1)^2$$

$$17. \quad y = \frac{x}{10}$$

$$18. \quad y = \frac{wxv}{stu}$$

### APPLICATIONS

For Exercises 19–23, use the following situation:

Two students create a downloadable app which connects dots on a grid so that two players can play “Chase the Rabbit.” They have developed a website on which to promote and sell the app for \$5.00 and they pay an outside vendor \$0.50 per purchase to manage the payments. They also pay another student \$27/day (5 days a week) to monitor a customer service email box to answer questions and relay orders.

Let  $x$  denote the number of copies of the app sold, let  $C(x)$  be the weekly total cost function (linear), and let  $R(x)$  be the revenue function.

19. **a.** Write the expression for  $C(x)$ .  
**b.** Determine the weekly cost of selling 500 copies of the app.
20. **a.** Write the revenue function.  
**b.** How much revenue is produced by the sale of 500 copies of the app.

21.
  - a. Write the profit function.
  - b. Determine the profit from the sale of 500 copies of the app.
22. How many copies of the app must be sold in order to break even?
23. A business professor estimates that the campus craze for the game could become national, and, therefore, the game could be marketed nationally. If 100 colleges were to become market sites, find a profit function for all 100 colleges together. Assume total profits and the number of colleges involved are directly proportional.

For Exercises 24–28, use the following information:

An ideal gas satisfies a law which may be stated as  $\frac{PV}{T} = 0.821n$  where  $P$  is the pressure in atmospheres (atm),  $V$  is the volume in liters (L),  $T$  is the temperature in kelvins (K) ( $K = 273 + C$ , where  $C$  is the temperature in degrees Celsius), and  $n$  is the number of moles (gram molecular weights). Thus, for one mole of gas, pressure and volume are indirectly proportional for a constant temperature, pressure and temperature are directly proportional for a fixed volume, and volume and temperature are directly proportional for a fixed pressure.

Assume, if necessary, that there is 1 mole ( $6.023 \times 10^{23}$  molecules) present.

24. What volume is occupied by 1 mole of gas at a temperature of 300 K and a pressure of 2 atm?
25. A fixed volume of gas is heated from a temperature of 200 K and 0.5 atm of pressure to 300 K. What is the new pressure?
26. A gas at a pressure of 2 atm expands, at constant temperature, from 10 L to 15 L. What is the new pressure?
27. One mole of gas occupies a volume of 2 L and has a temperature of 136.5 K. What is the pressure in atmospheres?
28. A gas has a volume of 2 L, a temperature of 30 °C and a pressure of 1 atm. When the gas is heated to 60 °C and its volume is compressed to a volume of 1.25 L, what is its new pressure? (**Hint:** For this problem,  $n \neq 1$ .)
29. **Modeling in business:** The manager of a pie shop sells his pies for \$6.50. The overhead is \$378 per day and each pie costs \$1.10 to make.
  - a. Write the revenue function.
  - b. Write the cost function.
  - c. Write the profit function.
  - d. Find the break-even point.
30. **Modeling in business:** A certain style of athletic shoe costs \$11.80 per pair to produce. The fixed costs are \$864 per week. The shoes can be sold for \$19.00 per pair.
  - a. Write the revenue function.
  - b. Write the cost function.
  - c. Write the profit function.
  - d. Find the break-even point.

- 31. Modeling in manufacturing:** A manufacturer of golf clubs finds that the fixed costs are \$5780 per week and the cost of producing each set of clubs is \$73.00. Each set of clubs can be sold for \$243.00.
- Write the revenue function.
  - Write the cost function.
  - Write the profit function.
  - Find the break-even point.
- 32. Modeling in business:** A soft drink company has fixed costs of \$4000 per day. The variable costs are \$2.75 per case of soda. Each case sells for \$5.25.
- Write the revenue function.
  - Write the cost function.
  - Write the profit function.
  - Find the break-even point.
- 33. Modeling in production:** The cost of producing 200 pens is \$290. Producing 250 pens would cost \$297.50.
- Find the average cost per pen for additional 50 pens over 200.
  - Assuming the total cost function is linear, write an equation for the cost of producing  $x$  pens.
  - What are the fixed costs?
- 34. Modeling in production:** The Blue Umbrella Company can produce 500 umbrellas per week at a cost of \$1800. It would cost \$1950 to produce 600 umbrellas.
- Find the average cost of each of the additional 100 umbrellas over 500.
  - Assuming the total cost is a linear function, write an equation for the cost of producing  $x$  umbrellas.
  - What are the fixed costs?
- 35. Revenue-profit:** It has been determined that the cost of producing  $x$  units of a certain item is  $11x + 500$ . The demand function is given by  $p = D(x) = 31 - 0.5x$ .
- Write the revenue function.
  - Write the profit function.
- 36. Modeling in sales:** The manager of a men's store knows he can sell 60 pairs of a certain style of sock when the price is \$1.20 per pair. If the price is \$1.50, he can sell only 48 pairs of socks. The total cost function for  $x$  pairs of socks is  $C(x) = 0.70x + 15$  dollars.
- Assuming the demand function is linear, write an equation for  $D(x)$ .
  - Write the revenue function.
  - Write the profit function.
- 37. Modeling in manufacturing:** A manufacturer of TVs can sell 800 TVs to his dealers at \$384 each. If the price is \$380, he can sell 1000 TVs. The total cost of producing  $x$  TVs is  $C(x) = 3600 + 250x - 0.01x^2$  dollars.
- Assuming the demand function is linear, write an equation for  $D(x)$ .
  - Write the revenue function.
  - Write the profit function.

- 38. Revenue:** Suppose the revenue  $R$  from the sale of a product is directly proportional to the number of units  $x$  of the product that are sold. Suppose also that the revenue from the sale of 65 units of the product is \$1820.
- Write a function for  $R$  in terms of  $x$ .
  - Find the revenue if 75 units are sold.
- 39. Interest:** Suppose the annual interest  $I$  earned on an investment is directly proportional to the amount of money invested  $P$ . Suppose also that an investment of \$8200 earns an annual interest of \$512.50.
- Write a function for  $I$  in terms of  $P$ .
  - Find the annual interest earned by \$6000.
- 40. Interest:** What will \$6000 accumulate to if it is deposited in a bank for three years and earns 5% a year with annual compounding?
- 41. Price:** Suppose that for a certain product, the price per item  $p$  is inversely proportional to the number of items sold  $x$ . Suppose also that the price per item is \$8.50 when 40 items are sold.
- Write a function for  $p$  in terms of  $x$ .
  - Find the price if 34 items are sold.
- 42. Demand:** Pat has decided to produce a limited number of prints from one of her paintings. She plans to issue  $x$  prints, where  $0 < x \leq 50$ . If she wants her revenue to be \$5000, write a function for the demand  $D(x)$ .
- 43. Number of orders:** The owner of a camera shop expects to sell 800 cameras of a particular style during the year. How many orders will the dealer need to place with his distributor if each order is for  $x$  cameras?
- 44. Salary:** A salesperson's weekly salary depends on the amount of her sales. Her salary is \$250 per week plus a commission of 8% of her weekly sales in excess of \$2500. Write a function for her salary if her sales were  $x$  dollars.
- 45. International calls:** For an international call, the telephone company charges 65 cents for the first 3 minutes or less, plus 15 cents for each additional minute. Write a cost function for a call  $x$  minutes long.
- 46. Car rental:** The rate for renting a car at a local agency is \$22.50 per day plus \$0.10 for each mile driven in excess of 100. If a car is rented for one day, write a function for the cost in terms of the number of miles driven.
- 47. Agriculture:** A farmer cultivates bananas. They cost him 38 cents per bunch to produce. He is able to sell only 85% of those he produces. If he sells his bananas at 75 cents per bunch, find a function for his profit in terms of the number of bunches he produces.
- 48. Retail profit:** A grocery store bought bags of frozen corn for 59 cents per bag and stored it in two freezers. During the night, one freezer defrosted and ruined 14 bags. If the remaining frozen corn was sold for 98 cents per bag, find a function for the profit in terms of the number of bags bought.

49. **Retail profit:** It costs Liz \$12 to build a picture frame. She estimates that, if she charges  $x$  dollars per frame, she can sell  $60 - x$  frames per week. Write a function for her weekly profit.
50. **Retail profit:** A toy retailer pays \$3 each for a particular doll. He estimates that, if he charges  $x$  dollars for each doll, he will be able to sell  $300 - 20x$  dolls. Write a function for his profit.
51. **Area:** The perimeter of a rectangle is 276 feet. If the rectangle is  $x$  feet long, write a function for the area  $A(x)$ .
52. **Perimeter:** The area of a rectangle is  $426 \text{ cm}^2$ . If the length of the rectangle is  $x$  centimeters, write a function for the perimeter  $P(x)$ .
53. **Perimeter:** The area of a rectangle is  $288 \text{ ft}^2$ . If the length of the rectangle is  $x$  feet, write a function for the perimeter  $P(x)$ .
54. **Area:** The perimeter of a rectangle is 197 inches. If the rectangle is  $x$  inches wide, write a function for the area  $A(x)$ .
55. **Construction:** The maintenance department at the city zoo wants to build a pen and divide it as shown in the diagram. If the department has a total of 720 feet of fencing, write a function for the area in terms of  $x$ .

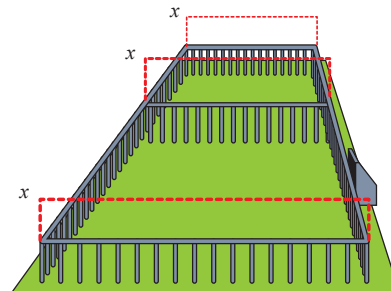

56. **Cafeteria costs and revenue:** After applying federal reimbursement funds, a certain high school's breakfast program has daily operating costs (in dollars) given by  $C(x) = 0.5x + 300$ , where  $x$  is the number of students served. The school charges \$0.75 per student for breakfast.
- If the school usually serves breakfast to 1000 students, how much is the average daily loss in operations?
  - How many students need to buy breakfast on any given day in order to break even?
57. **Break-even point:** If a vendor of hot dogs at high school baseball games profits \$100 on the sale of 300 hot dogs and \$130 on the sale of 360 hot dogs, how many must be sold in order to break even? Assume there is a linear relationship between profit and the number of hot dogs sold.

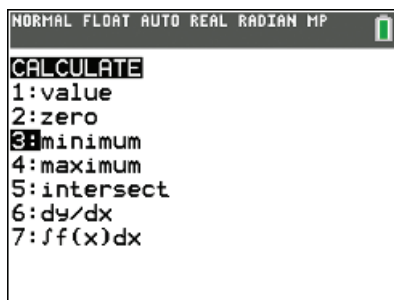

FIGURE 12

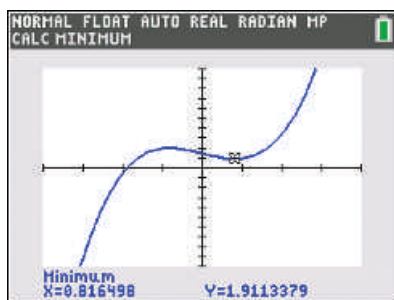

FIGURE 13

## Finding a Minimum or Maximum Value of a Function

For the function in Example 4, note that there is an interesting dip downward between  $x = 0$  and  $x = 2$ . Let us determine the minimum  $y$ -value in this interval. With the function  $x^3 - 2x + 3$  typed into **Y1**, and with a window that includes the interval from  $x = 0$  to  $x = 2$ , press **graph** and then **2nd trace** (for the **CALCULATE** menu), and select **3:minimum**. You can do this by using the down arrow and pressing **enter**, or just by pressing **3**.

You will be prompted for a left bound; press **0** and **enter**. You will then be prompted for a right bound; press **2** and **enter**. Finally, you will be prompted for a guess; press **1** and **enter**. The result

Minimum  
X=0.816498 Y=1.9113379

will appear at the bottom of the screen. Thus, the minimum value of the function,  $y = 1.9113379$ , occurs at  $x = 0.816498$ . Similarly, we can find a maximum value of a function by selecting **4:maximum** from the **CALCULATE** menu.

## 1.4 EXERCISES

### 💡 PRACTICE

In Exercises 1–8, express each function (using parentheses,  $^$ ,  $\div$ , etc.) in a form suitable for typing into a graphing calculator.

1.  $f(x) = 1 + 3x + \sqrt{x}$
2.  $f(x) = 3x - 2 + \sqrt[3]{x}$
3.  $f(x) = \frac{3x}{\sqrt{x-1}}$
4.  $f(x) = \frac{1 + \sqrt{x}}{2 - 3x}$
5.  $f(x) = \frac{(-3x + 16)^4}{3x + 6}$
6.  $f(x) = \sqrt{2 + 5x + \sqrt{x}}$
7.  $f(x) = \left(2x^{\frac{2}{3}} + 3x^{\frac{5}{3}}\right)^5$
8.  $f(x) = \left(9x^{\frac{1}{5}} + 2x^{\frac{3}{5}}\right)^{10}$

### 📊 TECHNOLOGY

In Exercises 9–22, graph the given function in the standard window  $[-10, 10]$  by  $[-10, 10]$ . Explain in a sentence why the standard window is not suitable for the graph of the function. Then find a more appropriate window, which reveals the significant parts of the graph.

9.  $f(x) = \frac{3x - 25}{\sqrt{x^2 + 5}}$
10.  $f(x) = (3x + 4)^2 (5x - 25)^2$
11.  $f(x) = (6x + 30)^2 (3x - 15)^2$
12.  $f(x) = (40 + 3x)\sqrt{16 - x}$
13.  $f(x) = 35 + 17x - x^2 - x^3$
14.  $f(x) = 210 - 80x + x^3$

15.  $f(x) = 35 + 56x - 14x^2$

16.  $f(x) = 25 + 50x - 10x^2$

17.  $f(x) = \sqrt[3]{x^3 - x^2 - x - 50}$

18.  $f(x) = \sqrt[3]{x^4 - 3x^2 - 3x - 30}$

19.  $f(x) = (10 + 2x - 25x^2)^{\frac{1}{3}}$

20.  $f(x) = (30 - 11x + x^2)^{\frac{1}{3}}$

21.  $f(x) = (12 - 6x - x^2)^{\frac{4}{3}}$

22.  $f(x) = (x^3 - x - 100)^{\frac{1}{3}}$

Graph each function in the window shown in Exercises 23–30. Make a table of  $x$ - and  $y$ -values for the values  $x = -2, -1, 0,$  and  $2$ . Then find all the zeros of the function in the given  $x$ -interval.

23.  $f(x) = 10 + 5x - 6x^3$ ;  $[-4, 4]$  by  $[-20, 20]$

24.  $f(x) = \frac{5^x + 3}{25x^2 + 3x + 3} - 2$ ;  $[-4, 4]$  by  $[-5, 5]$

25.  $f(x) = \frac{x\sqrt[3]{x-5}}{1+x}$ ;  $[-2, 8]$  by  $[-5, 5]$

26.  $f(x) = \frac{(2 + 3x - x^2)(14 - x)}{\sqrt{x^2 + 20}}$ ;  $[-5, 20]$  by  $[-5, 5]$

27.  $s(x) = (x - 3)(-16x^2 + 32x - 70)$ ;  $[-3, 8]$  by  $[-200, 400]$

28.  $s(x) = (x^2 + 3)(3 - 40x + x^2)^{\frac{1}{2}}$ ;  $[-5, 5]$  by  $[-200, 200]$

29.  $u(x) = (3 - 12x + 18x^{\frac{3}{2}})^{\frac{1}{2}}$ ;  $[-5, 5]$  by  $[-8, 12]$

30.  $u(x) = \frac{(32 - 11x)^2(x + 3)}{\sqrt{12 + x}}$ ;  $[-5, 9]$  by  $[-1200, 1600]$

For Exercises 31–40, graph the function in a suitable window and find the smallest  $y$ -value possible, or the smallest in the  $x$ -interval specified.

31.  $f(x) = x^2 - 104x + 2724$

32.  $f(x) = \frac{-1 - x^2 - 3x^3}{5^x}$

33.  $f(x) = x^3 - 17x + 5$ ;  $-3 \leq x \leq 5$

34.  $f(x) = \frac{\sqrt[3]{x} - 150}{5 + x^2}$

35.  $f(x) = x^{1.5} - 8x - 15$

36.  $f(x) = x^{1.8} - x - 100$

37.  $f(x) = 2^x - 50x$

38.  $f(x) = (1.5)^{x+1} - (x+1)^5$ ;  $-5 \leq x \leq 5$

39.  $f(x) = 17^x - x^{17}$ ;  $-2 \leq x \leq 2$

40.  $f(x) = (-x)(3^{-x})$

## 2.1 EXERCISES

 PRACTICE

In Exercises 1–6, determine the limits. In each case, make a suitable table, with four values, to support your answer. Choose the fourth value  $\pm 0.001$  from the indicated  $a$ -value.

1.  $\lim_{x \rightarrow 7^-} \left( \frac{x^2 - 49}{x - 7} \right)$

2.  $\lim_{x \rightarrow 7^+} \left( \frac{x^2 + 49}{x - 7} \right)$

3.  $\lim_{x \rightarrow 3^+} \left( \frac{x^3 - 9x^2 + 27x - 27}{x - 3} \right)$

4.  $\lim_{h \rightarrow 0^+} \left( \frac{\sqrt{4+h}}{h} \right)$

5.  $\lim_{a \rightarrow 1^+} \left( \frac{a^{10} - 1}{a - 1} \right)$

6.  $\lim_{n \rightarrow \sqrt{2}^-} \left( \frac{n^2 - 2}{n - \sqrt{2}} \right)$

Given the table for  $\lim_{x \rightarrow a^+} f(x)$  in Exercise 7 and  $\lim_{x \rightarrow a^-} f(x)$  in Exercises 8–9, **a.** give the value for  $a$  and **b.** determine the limit, if there is one.

7.

$x$	$y$
2.500	0.2222
2.100	0.2439
2.010	0.2494
2.001	0.2499

8.

$x$	$y$
3.800	15.60
3.900	15.80
3.990	15.98
3.999	15.998

9.

$x$	$y$
3.000	3.43
3.100	11.99
3.140	313.90
3.141	843.60

10. **a.** Complete the table.

$x$	$f(x) = 3x - 1$
1	
1.4	
1.8	
1.9	
1.99	
1.999	

**b.** Find  $\lim_{x \rightarrow 2^-} (3x - 1)$ .

11. **a.** Complete the table.

$x$	$f(x) = x^2 - 2$
0	
-0.4	
-0.8	
-0.9	
-0.99	
-0.999	

**b.** Find  $\lim_{x \rightarrow -1^+} (x^2 - 2)$ .

12. **a.** Complete the table.

$x$	$f(x) = \frac{x^2 - 1}{x + 1}$
2	
1.6	
1.2	
1.1	
1.01	
1.001	

**b.** Find  $\lim_{x \rightarrow 1^+} \left( \frac{x^2 - 1}{x + 1} \right)$ .

13. **a.** Complete the table.

$x$	$f(x) = x^2 + 3$
2	
2.4	
2.8	
2.9	
2.99	
2.999	

**b.** Find  $\lim_{x \rightarrow 3^-} (x^2 + 3)$ .

14. a. Complete the table.

$x$	$f(x) = \frac{1}{x-4}$
3	
3.4	
3.8	
3.9	
3.99	
3.999	

b. Find  $\lim_{x \rightarrow 4^+} \left( \frac{1}{x-4} \right)$ .

16. a. Complete the table.

$x$	$f(x) = \frac{x^2 - 4}{x + 2}$
-1	
-1.4	
-1.8	
-1.9	
-1.99	
-1.999	

b. Find  $\lim_{x \rightarrow -2^+} \left( \frac{x^2 - 4}{x + 2} \right)$ .

15. a. Complete the table.

$x$	$f(x) = \frac{x}{x+2}$
-3	
-2.6	
-2.2	
-2.1	
-2.01	
-2.001	

b. Find  $\lim_{x \rightarrow -2^-} \left( \frac{x}{x+2} \right)$ .

17. a. Complete the table.

$x$	$f(x) = \frac{x-3}{x^2 - 2x - 3}$
4	
3.6	
3.2	
3.1	
3.01	
3.001	

b. Find  $\lim_{x \rightarrow 3^+} \left( \frac{x-3}{x^2 - 2x - 3} \right)$ .

Find In Exercises 18–23, use the graph of  $y = f(x)$  to find the limits.

18.  $\lim_{x \rightarrow -1^-} f(x)$

19.  $\lim_{x \rightarrow -1^+} f(x)$

20.  $\lim_{x \rightarrow 2^-} f(x)$

21.  $\lim_{x \rightarrow 2^+} f(x)$

22.  $\lim_{x \rightarrow 3^-} f(x)$

23.  $\lim_{x \rightarrow 3^+} f(x)$

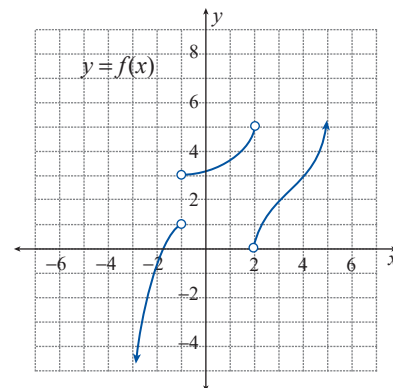

In Exercises 24–29, use the graph of  $y = f(x)$  to find the limits.

24.  $\lim_{x \rightarrow -1^-} f(x)$

25.  $\lim_{x \rightarrow -1^+} f(x)$

26.  $\lim_{x \rightarrow 0^-} f(x)$

27.  $\lim_{x \rightarrow 0^+} f(x)$

28.  $\lim_{x \rightarrow 3^-} f(x)$

29.  $\lim_{x \rightarrow 3^+} f(x)$

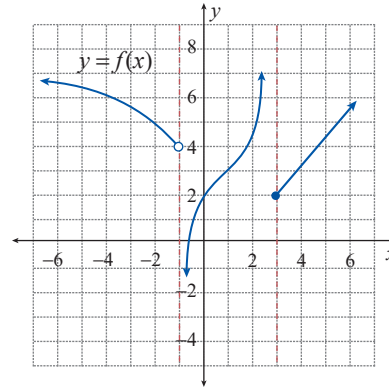

In Exercises 30–35, use the graph of  $y = f(x)$  to find the limits.

30.  $\lim_{x \rightarrow 0^-} f(x)$

31.  $\lim_{x \rightarrow 0^+} f(x)$

32.  $\lim_{x \rightarrow 4^-} f(x)$

33.  $\lim_{x \rightarrow 4^+} f(x)$

34.  $\lim_{x \rightarrow 2^-} f(x)$

35.  $\lim_{x \rightarrow 2^+} f(x)$

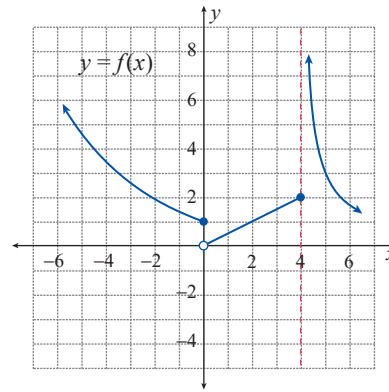

Find the one-sided limits indicated in Exercises 36–59.

36.  $\lim_{x \rightarrow 2^+} (5x - 3)$

37.  $\lim_{x \rightarrow -1^+} (2x + 7)$

38.  $\lim_{x \rightarrow 0^-} (4 - 3x)$

39.  $\lim_{x \rightarrow 3^-} (1 - 6x)$

40.  $\lim_{x \rightarrow 2^-} (x^2 - 3x + 1)$

41.  $\lim_{x \rightarrow -5^+} (x^2 + 4x - 2)$

42.  $\lim_{x \rightarrow -4^+} (x^2 - x + 3)$

43.  $\lim_{x \rightarrow -3^-} (x^2 + 2x - 3)$

44.  $\lim_{x \rightarrow 10^-} (0.01x^2 + 7x - 30)$

45.  $\lim_{x \rightarrow 10^+} (0.2x^2 - 5x + 6)$

46.  $\lim_{x \rightarrow 0^+} \left( \frac{x-3}{x} \right)$

47.  $\lim_{x \rightarrow 0^-} \left( \frac{2x+1}{x} \right)$

48.  $\lim_{x \rightarrow 1^+} \left( \frac{x-2}{x-1} \right)$

49.  $\lim_{x \rightarrow 1^-} \left( \frac{x-2}{x-1} \right)$

50.  $\lim_{x \rightarrow 2^-} \left( \frac{1}{x+2} \right)$

51.  $\lim_{x \rightarrow 2^+} \left( \frac{1}{x+2} \right)$

52.  $\lim_{x \rightarrow 3^+} \left( \frac{1}{x+1} \right)$

53.  $\lim_{x \rightarrow 1^+} \left( \frac{1}{x-5} \right)$

$$54. f(x) = \begin{cases} 2-3x & \text{if } x < 2 \\ x-1 & \text{if } x \geq 2 \end{cases}$$

$$\text{a. } \lim_{x \rightarrow 2^-} f(x)$$

$$\text{b. } \lim_{x \rightarrow 2^+} f(x)$$

$$56. f(x) = \begin{cases} 3x+1 & \text{if } 0 \leq x \leq 4 \\ x^2-3 & \text{if } x > 4 \end{cases}$$

$$\text{a. } \lim_{x \rightarrow 4^-} f(x)$$

$$\text{b. } \lim_{x \rightarrow 4^+} f(x)$$

$$58. f(x) = \begin{cases} 3-2x & \text{if } x < 1 \\ x & \text{if } 1 \leq x \leq 4 \\ \frac{1}{x-4} & \text{if } x > 4 \end{cases}$$

$$\text{a. } \lim_{x \rightarrow 1^-} f(x) \quad \text{b. } \lim_{x \rightarrow 1^+} f(x)$$

$$\text{c. } \lim_{x \rightarrow 4^-} f(x) \quad \text{d. } \lim_{x \rightarrow 4^+} f(x)$$

$$55. f(x) = \begin{cases} x^2+2 & \text{if } 0 \leq x \leq 3 \\ 2x+5 & \text{if } x > 3 \end{cases}$$

$$\text{a. } \lim_{x \rightarrow 3^-} f(x)$$

$$\text{b. } \lim_{x \rightarrow 3^+} f(x)$$

$$57. f(x) = \begin{cases} x^3 & \text{if } x < 2 \\ x^2+5 & \text{if } x \geq 2 \end{cases}$$

$$\text{a. } \lim_{x \rightarrow 2^-} f(x)$$

$$\text{b. } \lim_{x \rightarrow 2^+} f(x)$$

$$59. f(x) = \begin{cases} x^2-1 & \text{if } 0 \leq x < 2 \\ 3 & \text{if } 2 \leq x \leq 5 \\ \frac{1}{x-5} & \text{if } x > 5 \end{cases}$$

$$\text{a. } \lim_{x \rightarrow 2^-} f(x) \quad \text{b. } \lim_{x \rightarrow 2^+} f(x)$$

$$\text{c. } \lim_{x \rightarrow 5^-} f(x) \quad \text{d. } \lim_{x \rightarrow 5^+} f(x)$$

### 🔑 APPLICATIONS

- 60. Parking rates:** The rate for parking in the short-term lot (maximum of 24 hours) at the airport is \$1.00 for the first hour plus \$0.75 for each additional hour or part thereof, with a maximum cost of \$7.00. The function for the cost of parking on this lot for  $t$  hours (up to 24 hours) is as follows.

$$C(t) = \begin{cases} 1.00 & \text{for } 0 < t \leq 1 \\ 1.75 & \text{for } 1 < t \leq 2 \\ 2.50 & \text{for } 2 < t \leq 3 \\ 3.25 & \text{for } 3 < t \leq 4 \\ 4.00 & \text{for } 4 < t \leq 5 \\ 4.75 & \text{for } 5 < t \leq 6 \\ 5.50 & \text{for } 6 < t \leq 7 \\ 6.25 & \text{for } 7 < t \leq 8 \\ 7.00 & \text{for } 8 < t \leq 24 \end{cases}$$

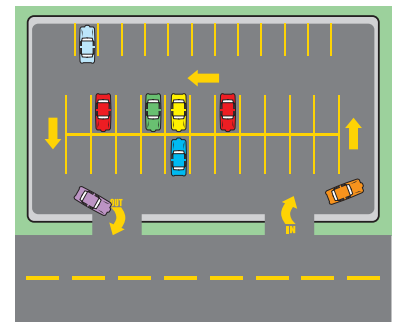

- Graph the function for  $0 < t \leq 24$  hr.
- Find  $\lim_{t \rightarrow 3^-} C(t)$ .
- Find  $\lim_{t \rightarrow 3^+} C(t)$ .
- Find  $\lim_{t \rightarrow 8^-} C(t)$ .
- Find  $\lim_{t \rightarrow 8^+} C(t)$ .

### ✍️ WRITING & THINKING

- 61.** Suppose  $f(x)$  and  $g(x)$  are polynomials and  $f(t) = 0 = g(t) = 0$  for some  $t$ . If

$$\lim_{x \rightarrow t^-} \frac{f(x)}{g(x)} = L, \text{ must } \lim_{x \rightarrow t^+} \frac{f(x)}{g(x)} \text{ also be } L?$$

## Indeterminate Form

A limit expression of the type  $\lim_{x \rightarrow a} \left( \frac{g(x)}{f(x)} \right)$  is called an **indeterminate form** of type  $\frac{0}{0}$  if  $\lim_{x \rightarrow a} g(x) = 0$  and  $\lim_{x \rightarrow a} f(x) = 0$ .

A strategy of solving such a problem is given by the two-step method illustrated in the previous example.

1. Replace the quotient with a simplified expression after factoring.
2. Evaluate the new limit problem by substitution if the denominator does not have a limit of 0 as  $x \rightarrow a$ .

## 2.2 EXERCISES

 PRACTICE

In Exercises 1–12, use the graph to find the indicated limits, if they exist.

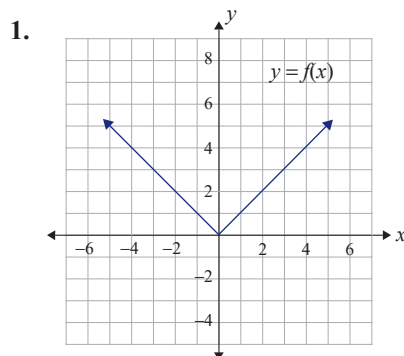

- a.  $\lim_{x \rightarrow 0^-} f(x)$     b.  $\lim_{x \rightarrow 0^+} f(x)$   
 c.  $\lim_{x \rightarrow 0} f(x)$     d.  $\lim_{x \rightarrow 2} f(x)$

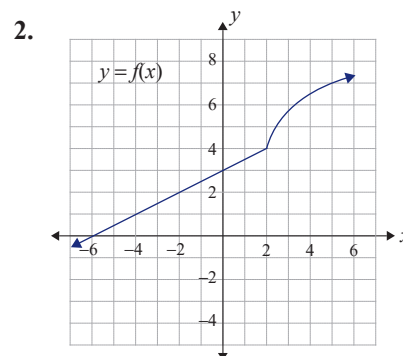

- a.  $\lim_{x \rightarrow 2^-} f(x)$     b.  $\lim_{x \rightarrow 2^+} f(x)$   
 c.  $\lim_{x \rightarrow 2} f(x)$     d.  $\lim_{x \rightarrow 0} f(x)$

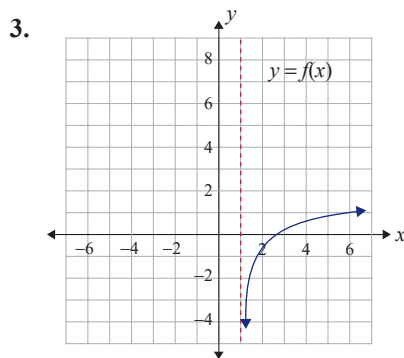

- a.  $\lim_{x \rightarrow 1^+} f(x)$     b.  $\lim_{x \rightarrow 6^-} f(x)$   
 c.  $\lim_{x \rightarrow 6^+} f(x)$     d.  $\lim_{x \rightarrow 6} f(x)$

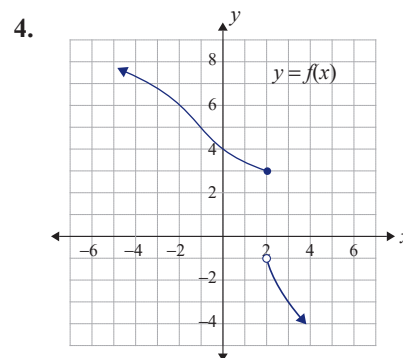

- a.  $\lim_{x \rightarrow 2^-} f(x)$     b.  $\lim_{x \rightarrow 2^+} f(x)$   
 c.  $\lim_{x \rightarrow 2} f(x)$     d.  $\lim_{x \rightarrow 0} f(x)$

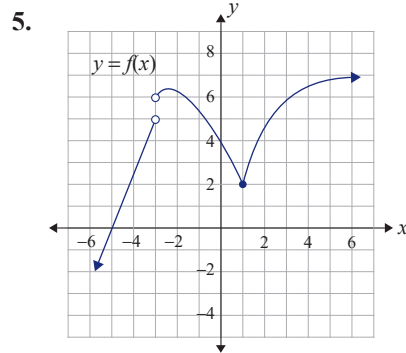

- a.  $\lim_{x \rightarrow -3^-} f(x)$     b.  $\lim_{x \rightarrow -3^+} f(x)$   
 c.  $\lim_{x \rightarrow -3} f(x)$     d.  $\lim_{x \rightarrow 1^-} f(x)$   
 e.  $\lim_{x \rightarrow 1^+} f(x)$     f.  $\lim_{x \rightarrow 1} f(x)$

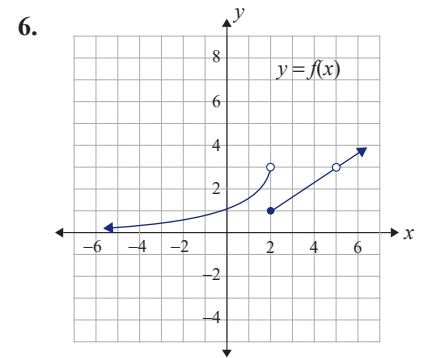

- a.  $\lim_{x \rightarrow 2^-} f(x)$     b.  $\lim_{x \rightarrow 2^+} f(x)$   
 c.  $\lim_{x \rightarrow 2} f(x)$     d.  $\lim_{x \rightarrow 5^+} f(x)$   
 e.  $\lim_{x \rightarrow 5^-} f(x)$     f.  $\lim_{x \rightarrow 5} f(x)$

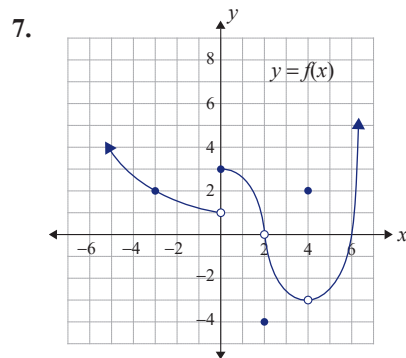

- a.  $\lim_{x \rightarrow 0^-} f(x)$     b.  $\lim_{x \rightarrow 0^+} f(x)$   
 c.  $\lim_{x \rightarrow 0} f(x)$     d.  $\lim_{x \rightarrow 4^-} f(x)$   
 e.  $\lim_{x \rightarrow 4^+} f(x)$     f.  $\lim_{x \rightarrow 4} f(x)$

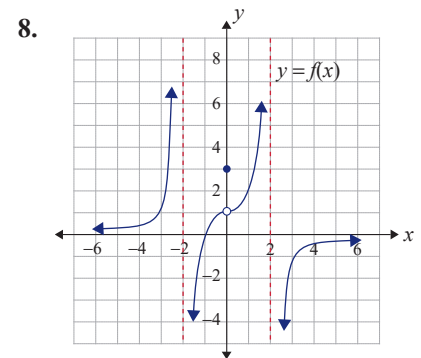

- a.  $\lim_{x \rightarrow -2^-} f(x)$     b.  $\lim_{x \rightarrow -2^+} f(x)$   
 c.  $\lim_{x \rightarrow 0^-} f(x)$     d.  $\lim_{x \rightarrow 0^+} f(x)$   
 e.  $\lim_{x \rightarrow 0} f(x)$     f.  $\lim_{x \rightarrow 3} f(x)$

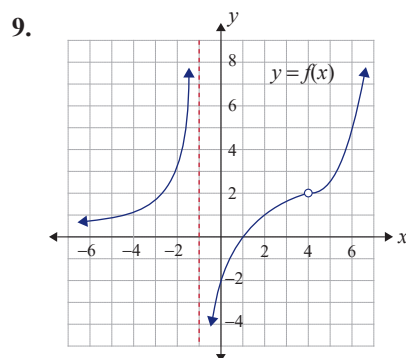

- a.  $\lim_{x \rightarrow -1^-} f(x)$     b.  $\lim_{x \rightarrow -1^+} f(x)$   
 c.  $\lim_{x \rightarrow 4^-} f(x)$     d.  $\lim_{x \rightarrow 4} f(x)$

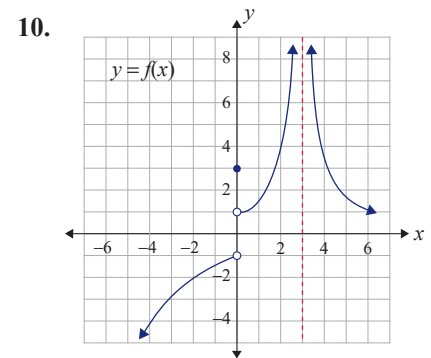

- a.  $\lim_{x \rightarrow 0^-} f(x)$     b.  $\lim_{x \rightarrow 0^+} f(x)$   
 c.  $\lim_{x \rightarrow 0} f(x)$     d.  $\lim_{x \rightarrow 3^-} f(x)$

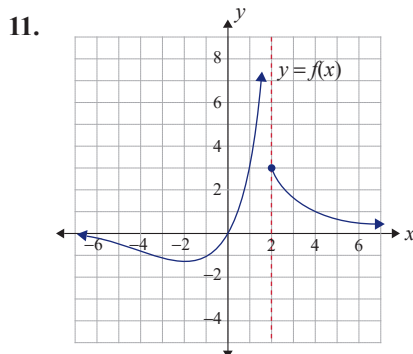

- a.  $\lim_{x \rightarrow 2^-} f(x)$     b.  $\lim_{x \rightarrow 2^+} f(x)$   
 c.  $\lim_{x \rightarrow 2} f(x)$     d.  $\lim_{x \rightarrow 0} f(x)$

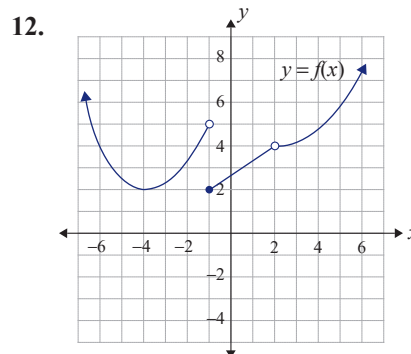

- a.  $\lim_{x \rightarrow -1^-} f(x)$     b.  $\lim_{x \rightarrow -1^+} f(x)$   
 c.  $\lim_{x \rightarrow -1} f(x)$     d.  $\lim_{x \rightarrow 2} f(x)$

In Exercises 13–19, determine the limit by first simplifying the expression algebraically.

13.  $\lim_{x \rightarrow 0} \left( \frac{x^3 + 2x}{2x^2 + x} \right)$

14.  $\lim_{x \rightarrow 3} \left( \frac{3 - 13x + 4x^2}{x - 3} \right)$

15.  $\lim_{x \rightarrow 6} \left( \frac{x^2 - 36}{x - 6} \right)$

16.  $\lim_{x \rightarrow -7} \left( \frac{x - 7}{x^2 - 49} \right)$

17.  $\lim_{h \rightarrow 0} \left( \frac{f(3+h) - f(3)}{h} \right), f(x) = x^2 - 2$

18.  $\lim_{h \rightarrow 0} \left( \frac{f(2-h) - f(2)}{h} \right), f(x) = 1 - x + x^2$

19.  $\lim_{x \rightarrow 4} \left( \frac{x^4 - 256}{x^2 - 16} \right)$

### 🔗 APPLICATIONS

20. **Salary:** Erin is paid a weekly salary of \$12 per hour plus time-and-a-half for overtime (time in excess of 40 hours, but no more than 60 hours). Her salary is given by the function

$$S(t) = \begin{cases} 12t & \text{if } 0 < t \leq 40 \\ 480 + 18(t - 40) & \text{if } 40 < t \leq 60 \end{cases}$$

where  $t$  is the time in hours,  $0 < t \leq 60$ .

- a. Find  $\lim_{t \rightarrow 40^-} S(t)$ .    b. Find  $\lim_{t \rightarrow 40^+} S(t)$ .    c. Find  $\lim_{t \rightarrow 40} S(t)$ .

### 📏 WRITING & THINKING

21. Suppose  $f(x)$  and  $g(x)$  are equal for all  $x$ -values except  $x = t$ .

- a. Is  $\lim_{x \rightarrow t^-} f(x) = \lim_{x \rightarrow t^-} g(x)$  true?  
 b. What about  $\lim_{x \rightarrow t^+} f(x) = \lim_{x \rightarrow t^+} g(x)$ ?  
 c. Is  $\lim_{x \rightarrow t} f(x) = \lim_{x \rightarrow t} g(x)$  necessarily true?

## Example 7: Properties of Limits

Find  $\lim_{x \rightarrow -\infty} \left( \frac{x^3 + x^2 - x + 1}{x^2 - 4} \right)$ , if it exists.

## Solution

$$\begin{aligned} \lim_{x \rightarrow -\infty} \left( \frac{x^3 + x^2 - x + 1}{x^2 - 4} \right) &= \lim_{x \rightarrow -\infty} \left( \frac{\frac{x^3}{x^3} + \frac{x^2}{x^3} - \frac{x}{x^3} + \frac{1}{x^3}}{\frac{x^2}{x^3} - \frac{4}{x^3}} \right) \\ &= \lim_{x \rightarrow -\infty} \left( \frac{1 + \frac{1}{x} - \frac{1}{x^2} + \frac{1}{x^3}}{\frac{1}{x} - \frac{4}{x^3}} \right) \\ &= \frac{1}{0} \end{aligned}$$

Divide each term by the highest power of  $x$  present, which in this function is  $x^3$ .

Simplify.

Since  $\frac{1}{0}$  is undefined, the limit is either  $+\infty$  or  $-\infty$ . (See Example 3.)

Investigating the expression shows that the highest power is  $x^3$ . This term will dominate for very large values of  $x$  and will be negative for negative values of  $x$ . Thus

$$\lim_{x \rightarrow -\infty} \left( \frac{x^3 + x^2 - x + 1}{x^2 - 4} \right) = -\infty.$$

Summary of Limits for Rational Functions as  $x \rightarrow +\infty$  (or  $x \rightarrow -\infty$ )

Consider the function

$$f(x) = \frac{a_n x^n + a_{n-1} x^{n-1} + \cdots + a_0}{b_m x^m + b_{m-1} x^{m-1} + \cdots + b_0},$$

where  $a_n \neq 0$  and  $b_m \neq 0$ .

**Case 1:** For  $m = n$ ,  $\lim_{x \rightarrow +\infty} f(x) = \frac{a_n}{b_m}$ .

**Case 2:** For  $m > n$ ,  $\lim_{x \rightarrow +\infty} f(x) = 0$ .

**Case 3:** For  $m < n$ ,  $\lim_{x \rightarrow +\infty} f(x) = +\infty$ . (Or  $-\infty$  depending on the signs of  $a_n$  and  $b_m$ .)

## 2.3 EXERCISES

## PRACTICE

In Exercises 1–28, find the indicated limit, if it exists.

1.  $\lim_{x \rightarrow -2} 6$

2.  $\lim_{x \rightarrow 4} 2x$

3.  $\lim_{x \rightarrow 3^-} (x^2 + 1)$

4.  $\lim_{x \rightarrow -3^+} (5 - 2x^2)$       5.  $\lim_{x \rightarrow 1^+} \left( \frac{x+2}{x-1} \right)$       6.  $\lim_{x \rightarrow 1^-} \left( \frac{x+2}{x-1} \right)$
7.  $\lim_{x \rightarrow \frac{1}{3}} \left( \frac{3x+1}{x+2} \right)$       8.  $\lim_{x \rightarrow 0^+} \left( \frac{x+4}{x-4} \right)$       9.  $\lim_{x \rightarrow 0^-} \left( \frac{x}{x^2+2x} \right)$
10.  $\lim_{x \rightarrow 0^-} \left( \frac{2x^2+x}{x} \right)$       11.  $\lim_{x \rightarrow +\infty} \left( \frac{x}{x^2+3} \right)$       12.  $\lim_{x \rightarrow +\infty} \left( \frac{2x^2+7}{3x^2-2} \right)$
13.  $\lim_{x \rightarrow -\infty} \left( \frac{x^3+64}{x^2-2x+1} \right)$       14.  $\lim_{x \rightarrow -\infty} \left( \frac{4x-x^3}{x^2+2x-7} \right)$       15.  $\lim_{x \rightarrow 2} \left( \frac{x^2-x-2}{x^2-4} \right)$
16.  $\lim_{x \rightarrow -3} \left( \frac{x^2-9}{x^2+2x-3} \right)$       17.  $\lim_{x \rightarrow 0^+} \left( 4 - \frac{3}{x} \right)$       18.  $\lim_{x \rightarrow 1^-} \left( 2x + \frac{5}{x-1} \right)$
19.  $\lim_{x \rightarrow +\infty} \left( 8 + \frac{1}{x} \right)$       20.  $\lim_{x \rightarrow -\infty} \left( 11 - \frac{2}{x^2} \right)$       21.  $\lim_{x \rightarrow 4} \sqrt{x+5}$
22.  $\lim_{x \rightarrow 2} \sqrt{3x+10}$       23.  $\lim_{x \rightarrow 1} (\sqrt{x}-3)$       24.  $\lim_{x \rightarrow 4} (\sqrt{x}+6)$
25. a.  $\lim_{x \rightarrow 4} \left( \frac{\sqrt{x}-2}{x-4} \right)$  [Hint:  $x-4 = (\sqrt{x}+2)(\sqrt{x}-2)$ ]  
 b.  $\lim_{x \rightarrow 9} \left( \frac{x-9}{\sqrt{x}-3} \right)$  [Hint:  $x-9 = (\sqrt{x}+3)(\sqrt{x}-3)$ ]
26. a.  $\lim_{h \rightarrow 0} \frac{\sqrt{2+h}-\sqrt{2}}{h}$  [Hint: Multiply by  $\frac{\sqrt{2+h}+\sqrt{2}}{\sqrt{2+h}+\sqrt{2}}$ , simplify the numerator, and calculate the limit.]  
 b.  $\lim_{h \rightarrow 0} \frac{\sqrt{5x+h}-\sqrt{5x}}{h}$
27.  $\lim_{x \rightarrow +\infty} \left( \frac{x^2+3x-4}{x^2+5x-9} \right)$       28.  $\lim_{x \rightarrow -\infty} \left( \frac{x^2+x+1}{2x^3+3x^2+x-2} \right)$
29. For the function  $f(x) = \begin{cases} -3 & \text{if } x \leq 1 \\ x-4 & \text{if } x > 1 \end{cases}$ , find the following limits.  
 a.  $\lim_{x \rightarrow 1^-} f(x)$     b.  $\lim_{x \rightarrow 1^+} f(x)$     c.  $\lim_{x \rightarrow 1} f(x)$     d.  $\lim_{x \rightarrow 2} f(x)$
30. For the function  $f(x) = \begin{cases} 2x+1 & \text{if } x < 0 \\ x^2+1 & \text{if } x \geq 0 \end{cases}$ , find the following limits.  
 a.  $\lim_{x \rightarrow 0^-} f(x)$     b.  $\lim_{x \rightarrow 0^+} f(x)$     c.  $\lim_{x \rightarrow 0} f(x)$     d.  $\lim_{x \rightarrow -2} f(x)$

31. For the function  $f(x) = \begin{cases} 5-x & \text{if } x \leq 2 \\ x^2-1 & \text{if } x > 2 \end{cases}$ , find the following limits.

a.  $\lim_{x \rightarrow 2^-} f(x)$    b.  $\lim_{x \rightarrow 2^+} f(x)$    c.  $\lim_{x \rightarrow 2} f(x)$    d.  $\lim_{x \rightarrow 0} f(x)$

32. For the function  $f(x) = \begin{cases} x^3+4 & \text{if } x \leq -2 \\ \sqrt{x^2+5} & \text{if } x > -2 \end{cases}$ , find the following limits.

a.  $\lim_{x \rightarrow -2^-} f(x)$    b.  $\lim_{x \rightarrow -2^+} f(x)$    c.  $\lim_{x \rightarrow -2} f(x)$    d.  $\lim_{x \rightarrow -1} f(x)$

### APPLICATIONS

33. **Utility costs:** The Municipal Gas Company uses the following function for computing their customers' monthly gas bills:

$$C(x) = \begin{cases} 0.37x + 3.00 & \text{if } 0 < x \leq 24 \\ 0.78x - 6.84 & \text{if } x > 24 \end{cases},$$

where  $x$  is the number of therms (thermal units) used and  $C(x)$  is the cost in dollars.

a. Find  $\lim_{x \rightarrow 24^-} C(x)$ .   b. Find  $\lim_{x \rightarrow 24^+} C(x)$ .   c. Find  $\lim_{x \rightarrow 24} C(x)$ .

34. **Income tax:** A federal income tax schedule can be given by the function

$$T(x) = \begin{cases} 0.15x & \text{if } 0 < x \leq 23,900 \\ 0.28x - 3107 & \text{if } 23,900 < x \leq 61,650 \\ 0.33x - 6189.50 & \text{if } 61,650 < x \leq 123,790 \end{cases},$$

where  $x$  is the taxable income in dollars,  $0 < x \leq 123,790$ , and  $T(x)$  is in dollars.

a. Find  $\lim_{x \rightarrow 23,900^-} T(x)$ .   b. Find  $\lim_{x \rightarrow 23,900^+} T(x)$ .

c. Find  $\lim_{x \rightarrow 23,900} T(x)$ .   d. Find  $\lim_{x \rightarrow 61,650} T(x)$ .

35. **Average cost:** A manufacturer of golf clubs estimates that if  $x$  sets of golf clubs are produced, then the average cost of producing each set is  $A(x) = 73 + \frac{5780}{x}$  dollars. What will be the average cost of producing each set in the long run  $\left(\lim_{x \rightarrow +\infty} A(x)\right)$ ?

36. **Dictation rate:** It has been determined that after  $t$  weeks of class, a certain student in an intermediate shorthand class can take dictation at a rate of  $W(t) = 60 + \frac{70t^2}{t^2+15}$  words per minute. What will be this student's rate of taking dictation in the long run  $\left(\lim_{t \rightarrow +\infty} W(t)\right)$ ?

## 2.4 EXERCISES

 PRACTICE

In Exercises 1–8, use the graph of  $y = f(x)$  to answer the questions regarding the function.

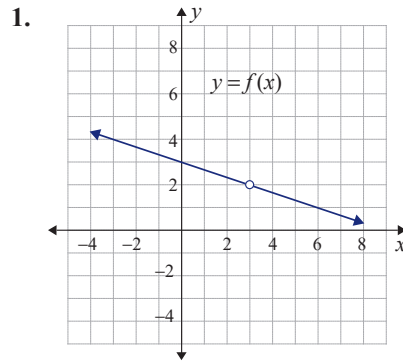

- Find  $\lim_{x \rightarrow 3^-} f(x)$ .
- Find  $\lim_{x \rightarrow 3^+} f(x)$ .
- Find  $f(3)$ .
- Is  $f(x)$  continuous at  $x = 3$ ? Explain.

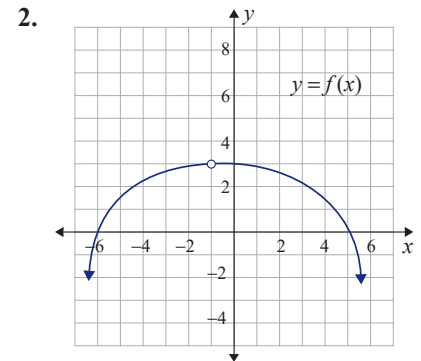

- Find  $\lim_{x \rightarrow -1^-} f(x)$ .
- Find  $\lim_{x \rightarrow -1^+} f(x)$ .
- Find  $f(-1)$ .
- Is  $f(x)$  continuous at  $x = -1$ ? Explain.

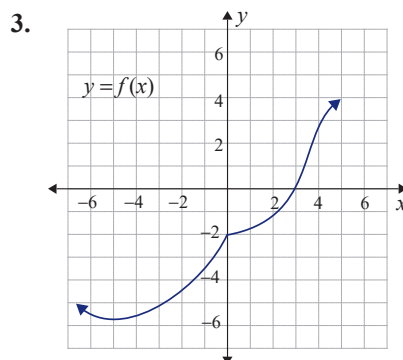

- Find  $\lim_{x \rightarrow 0^-} f(x)$ .
- Find  $\lim_{x \rightarrow 0^+} f(x)$ .
- Find  $f(0)$ .
- Is  $f(x)$  continuous at  $x = 0$ ? Explain.

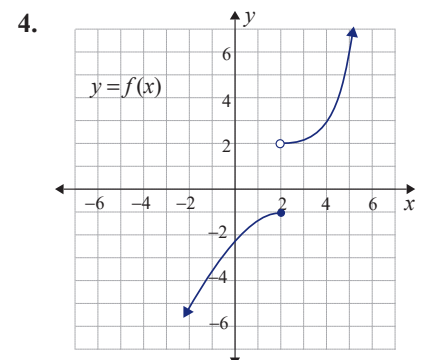

- Find  $\lim_{x \rightarrow 2^-} f(x)$ .
- Find  $\lim_{x \rightarrow 2^+} f(x)$ .
- Find  $f(2)$ .
- Is  $f(x)$  continuous at  $x = 2$ ? Explain.

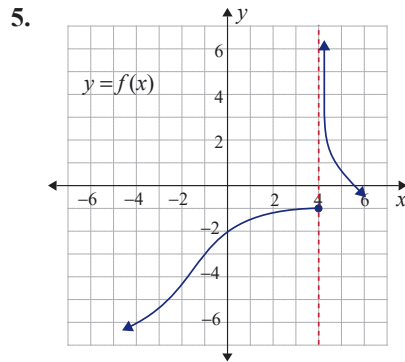

- Find  $\lim_{x \rightarrow 4^-} f(x)$ .
- Find  $\lim_{x \rightarrow 4^+} f(x)$ .
- Find  $f(4)$ .
- Is  $f(x)$  continuous at  $x = 4$ ? Explain.

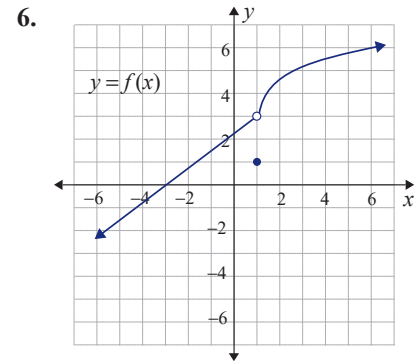

- Find  $\lim_{x \rightarrow 1^-} f(x)$ .
- Find  $\lim_{x \rightarrow 1^+} f(x)$ .
- Find  $f(1)$ .
- Is  $f(x)$  continuous at  $x = 1$ ? Explain.

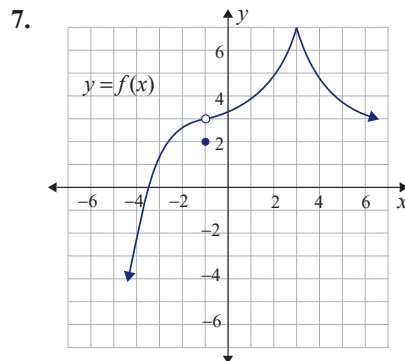

- Is  $f(x)$  continuous at  $x = -1$ ? Explain.
- Is  $f(x)$  continuous at  $x = 3$ ? Explain.

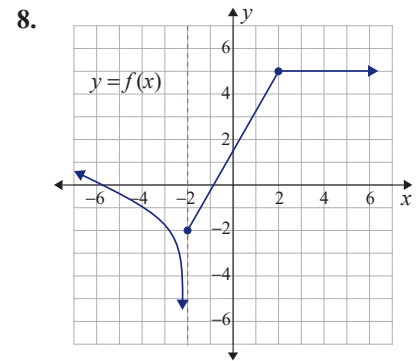

- Is  $f(x)$  continuous at  $x = 2$ ? Explain.
- Is  $f(x)$  continuous at  $x = -2$ ? Explain.

In Exercises 9–12, use the graph of  $y = f(x)$  to find the points of discontinuity, if any exist. Determine what type of discontinuity each is.

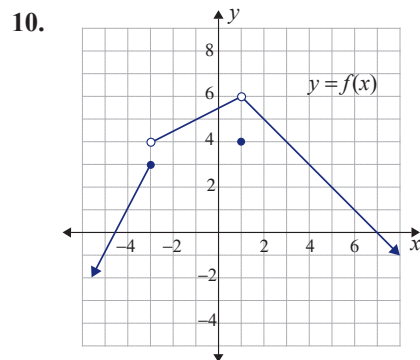
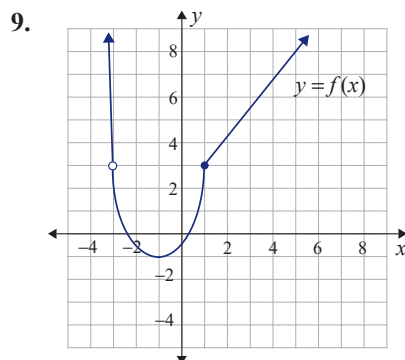

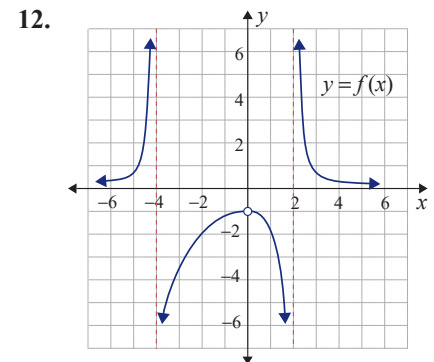
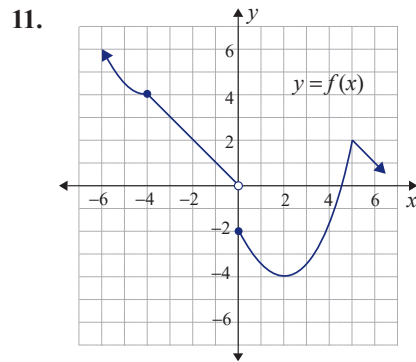

In Exercises 13–20, use the definition of continuity to determine whether or not the function is continuous at the given value of  $x$ .

13.  $f(x) = 3 - 2x$ ;  $x = 1$

14.  $f(x) = 5x - x^2$ ;  $x = 0$

15.  $f(x) = \frac{x^2 - x - 2}{x - 2}$ ;  $x = 2$

16.  $f(x) = \frac{x + 1}{x^2 - 1}$ ;  $x = 0$

17.  $f(x) = \begin{cases} 2x + 1 & \text{if } x \leq 1 \\ 3 & \text{if } x > 1 \end{cases}$ ;  $x = 1$

18.  $f(x) = \begin{cases} x^2 & \text{if } x \leq 2 \\ 2x & \text{if } x > 2 \end{cases}$ ;  $x = 2$

19.  $f(x) = \begin{cases} 1 - 3x & \text{if } x < 0 \\ 4x & \text{if } x \geq 0 \end{cases}$ ;  $x = 0$

20.  $f(x) = \begin{cases} \frac{x}{x - 3} & \text{if } x \neq 3 \\ 2 & \text{if } x = 3 \end{cases}$ ;  $x = 3$

In Exercises 21–28, find the points of discontinuity for each function, if any exist. Determine what type of discontinuity each is.

21.  $f(x) = 2x^2 + 3x - 1$

22.  $f(x) = 3x^2 - x + 7$

23.  $f(x) = \frac{5}{x + 3}$

24.  $f(x) = \frac{x + 8}{x}$

25.  $f(x) = \frac{x}{x^2 - 9}$

26.  $f(x) = \frac{2}{x^2 - 4x}$

27.  $f(x) = \begin{cases} 2 + 3x & \text{if } x \leq 1 \\ x^2 + 4 & \text{if } x > 1 \end{cases}$

28.  $f(x) = \begin{cases} x^2 + 1 & \text{if } x \leq 2 \\ 2x - 1 & \text{if } x > 2 \end{cases}$

In Exercises 29–32, find a value for  $k$  so that the given function will be continuous at the indicated value for  $x$ .

29.  $f(x) = \begin{cases} 3x & \text{if } x \leq 2 \\ x^2 + k & \text{if } x > 2 \end{cases}$ ;  $x = 2$

30.  $f(x) = \begin{cases} 7 & \text{if } x < -3 \\ k - 2x & \text{if } x \geq -3 \end{cases}$ ;  $x = -3$

31.  $f(x) = \begin{cases} 3x - k & \text{if } x \leq 1 \\ \frac{x^2 - 3x + 2}{x - 1} & \text{if } x > 1 \end{cases}$ ;  $x = 1$

32.  $f(x) = \begin{cases} \frac{x^2 + 3x}{x} & \text{if } x < 0 \\ 2x^2 - k & \text{if } x \geq 0 \end{cases}$ ;  $x = 0$

 APPLICATIONS

**33. Pricing:** A leather craft store has the following pricing policy for a belt buckle:

$$C(x) = \begin{cases} 0.79x & \text{if } 0 < x < 12 \\ 0.71x & \text{if } 12 \leq x < 50, \\ 0.67x & \text{if } x \geq 50 \end{cases},$$

where  $x$  is the number of buckles and  $C(x)$  is in dollars.

- Graph the function  $C(x)$ .
- Is  $C(x)$  a continuous function? Explain your answer.

**34. Salary:** A salesperson's weekly salary is determined by the function

$$S(x) = \begin{cases} 550 & \text{if } 0 < x < 10,000 \\ 0.06x & \text{if } x \geq 10,000 \end{cases},$$

where  $x$  is the weekly sales.

- Graph the function  $S(x)$ .
- Is  $S(x)$  a continuous function? Explain your answer.

**35. Cost of a phone call:** The cost of an overseas call is given by the function

$$C(x) = \begin{cases} 9.00 & \text{if } 0 < x \leq 3 \\ 0.95x + 6.15 & \text{if } x > 3 \end{cases},$$

where  $C(x)$  is in dollars and  $x$  is in minutes.

- Graph the function  $C(x)$ .
- Is  $C(x)$  a continuous function? Explain your answer.

**36. Revenue:** The revenue from the sale of a particular model of wireless speaker is given by the function

$$R(p) = \begin{cases} 84p & \text{if } 0 < p \leq 20 \\ 144p - 3p^2 & \text{if } p > 20 \end{cases},$$

where  $p$  is the price in dollars.

- Graph the function  $R(p)$ .
- Is  $R(p)$  a continuous function? Explain your answer.

## Solution

a.  $\Delta d = d_3 - d_0 = 144 - 0 = 144$  ft

Using data from Table 1

b.  $\frac{\Delta d}{\Delta t} = \frac{144 \text{ ft}}{3 \text{ sec}} = 48 \frac{\text{ft}}{\text{sec}}$

Using  $\Delta t = t_3 - t_0 = 3 - 0 = 3$  sec

c. We do not know how fast the ball is traveling when  $t = 3$  seconds. This is a question of instantaneous velocity, which we will discuss later.

## 2.5 EXERCISES

 PRACTICE

In Exercises 1–2, use the graph of  $f(x)$  to answer the questions.

1. What is the average rate of change of  $f(x)$  from  $x_1 = 1$  to  $x_2 = 5$ ?
2. What is the average rate of change of  $f(x)$  from  $x_1 = 5$  to  $x_2 = 8$ ?

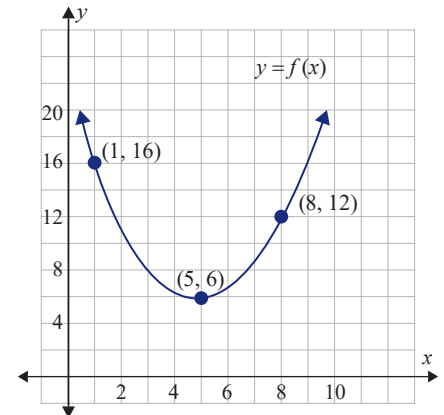

Use the graph to solve Exercises 3–4. The variable  $t$  is the number of hours since midnight and  $f(t)$  is the temperature at time  $t$ .

3. What is the average rate of change of  $f(t)$  from  $t = 0$  to  $t = 2$ ?
4. What is the average rate of change of  $f(t)$  from  $t = 6$  to  $t = 12$ ?

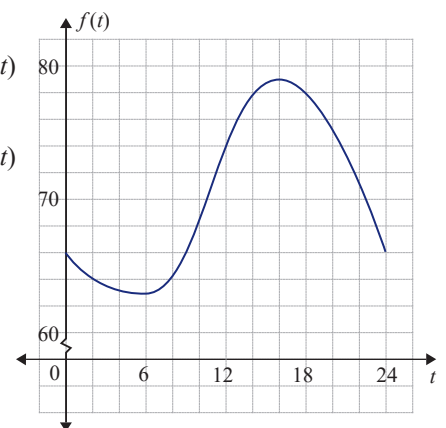

In Exercises 5–14, find the average rate of change of the given functions between the given values of  $x_1$  and  $x_2$ .

5.  $f(x) = 5x + 3$ ;  $x_1 = 1$ ,  $x_2 = 3$

6.  $f(x) = 3x + 8$ ;  $x_1 = -2$ ,  $x_2 = 1$

7.  $f(x) = 2x^2 - x - 3$ ;  $x_1 = 2$ ,  $x_2 = 2.5$

8.  $f(x) = 3x^2 - 2x - 1$ ;  $x_1 = 1$ ,  $x_2 = 1.5$

9.  $f(x) = \frac{-2}{2x-1}$ ;  $x_1 = 3$ ,  $x_2 = 3.5$       10.  $f(x) = \frac{2}{3x+2}$ ;  $x_1 = 0.5$ ,  $x_2 = 1$
11.  $f(x) = \sqrt{x}$ ;  $x_1 = 1$ ,  $x_2 = 2.5$       12.  $f(x) = \sqrt{x-3}$ ;  $x_1 = 4$ ,  $x_2 = 4.44$
13.  $f(x) = 2x - \sqrt{x}$ ;  $x_1 = 4$ ,  $x_2 = 4+h$       14.  $f(x) = \frac{3}{x+1}$ ;  $x_1 = x$ ,  $x_2 = x+h$

### APPLICATIONS

15. The population (in millions) for a country is modeled by

$$P(t) = 250 + 0.8t - 0.002t^2,$$

where  $t$  is the number of years since 2000.

- Interpret the meaning of  $P(0) = 250$ .
  - What population was predicted for 2010?
  - What was the average rate of change of population from 2000 to 2010?
16. The electrical charge on a new cell phone declines according to the formula  $f(t) = 10 - 0.2t^2 - 0.5t$ , where  $t$  is the time in hours following a full charge and  $f(t)$  is a measure of the charge. What is the average rate of change from  $t = 0$  to  $t = 5$ ?
17. When a factory operates from 6:00 a.m. to 6:00 p.m., its total fuel consumption varies according to the formula  $f(t) = 0.8t^2 - 0.1\sqrt{t} + 10$ , where  $t$  is the time in hours after 6:00 a.m. and  $f(t)$  is the number of barrels of fuel oil.
- How much fuel oil is consumed by noon?
  - What is the average rate of consumption from 6:00 a.m. to 12:00 p.m.?
18. The population of bacteria in a lab experiment for a biology class is given by  $f(t) = 4.4\sqrt{t} - 0.9t + 3$ , where  $t$  is the time in hours after 2:00 p.m. and  $f(t)$  is the population in suitable units.
- What is the population at 2:00 p.m.?
  - The lab is over at 4:00 p.m. What is the new population of bacteria?
  - What is the average rate of change of bacteria from 2:00 p.m. to 4:00 p.m.?

## 2.6 EXERCISES

 PRACTICE

Use the graph to solve Exercises 1–3. The variable  $t$  is the number of hours since midnight and  $f(t)$  is the temperature at time  $t$ .

1. Roughly estimate the instantaneous rate of change of  $f(t)$  at 3:00 p.m. (**Hint:** Extend an imaginary tangent line so as to come close to or to intersect points with integer coordinates.)
2. Estimate the time  $t$  for the lowest temperature  $f(t)$ .
3. Estimate the time  $t$  for the fastest increase in temperature  $f(t)$ .

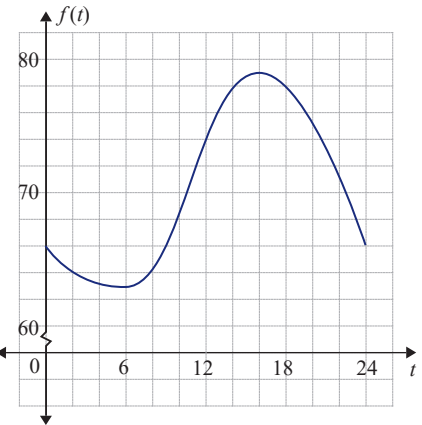

4. Sketch one graph so that all of the following statements are true.
 

<p>(a) <math>f'(x)</math> is positive for <math>-2 \leq x \leq 6</math>.</p> <p>(c) <math>f'(6) = 0</math></p>	<p>(b) <math>f'(x) &lt; 0</math> for <math>x &gt; 6</math></p> <p>(d) <math>f(6) = 10</math> and <math>f(0) = 1</math></p>
--	--
5. Interpret the meaning of  $f(3) = 14$  and  $f'(3) = 7$  for the function  $f(x) = 2 + x + x^2$ .

 APPLICATIONS

In Exercises 6–15, determine what the slope  $f'$  represents in terms of the subject in the problem.

6.  $f(t)$  is the distance in feet traveled by a car in  $t$  minutes.
7.  $f(s)$  is the total money spent in a department store by  $s$  customers.
8.  $f(n)$  is the number of birds nesting in woods with  $n$  trees per acre.
9.  $f(x)$  is the total cost of manufacturing  $x$  toasters.
10.  $f(u)$  is the total revenue from the sale of  $u$  car radios.
11.  $f(t)$  is the speed of a race car after  $t$  seconds.
12.  $f(v)$  is the total amount of information in bytes fed into a server at Castle Manufacturing Company in  $v$  seconds.
13.  $f(x)$  is the vertical distance in meters traveled by a test rocket in  $x$  seconds.
14.  $f(s)$  is the grade point average of freshmen at Sullivan Technical College where  $s$  is the average SAT score of the freshman class.
15.  $f(t)$  is the cost of calculus books at college bookstores in the United States where  $t$  is the time in years since 1980.

16. Suppose  $f(x)$  is the number of gallons of gas used by a car after it has traveled  $x$  miles.
- Suppose the car gets 20 miles/gallon. What is  $f(100)$ ?
  - Is  $f'(100)$  positive or negative?
  - Would  $f'(100)$  be greater for a subcompact car or for an SUV?
17. Suppose  $f(x)$  denotes the production units for input  $x$  in labor units (man-hours). Suppose  $f(500) = 2000$  and  $f'(500) = 3$ .
- Interpret  $f(500) = 2000$  and  $f'(500) = 3$ .
  - Estimate the increased production if  $x$  is increased from 500 to 501.
18. Suppose  $f(x)$  is the total number of students on a college campus that have the flu and  $x$  is the number of days after the first case is reported. Interpret  $f(8) = 9$  and  $f'(8) = 3$ .
19. Suppose  $f(x)$  is the cost of a Toyota Camry and  $x$  is the age of the car.
- Is  $f'(x)$  positive or negative?
  - Interpret the meaning of  $f'(3) = -2500$ .
20. Average prices for one-bedroom condominiums have steadily risen in Charleston, SC since 2000, according to local reports. Suppose  $f(x) = 3000x + 72,000$  is the cost of a one-bedroom condo and  $x$  is the number of years since 2000.
- Interpret  $f(0) = 72,000$ .
  - Interpret  $f'(x) = 3000$ .
  - Interpret  $f(3) = 81,000$ .
21. Suppose  $f(x)$  denotes the weight of a cancerous tumor  $x$  weeks after discovery. Interpret  $f(3) = 4$  grams and  $f'(3) = 0.4$  grams/week.
22. Water boils at 212 °F and at 100 °C. Water freezes at 32 °F and 0 °C. Let  $F$  denote temperature in degrees Fahrenheit and let  $x$  be temperature in degrees Celsius.
- Write a formula  $F(x) = mx + b$ , which can convert Celsius input  $x$  into Fahrenheit output  $F$ .
  - Use the value of  $m$  to write a formula for  $F'(x)$ .
23. **Birth rate:** The fertility decline in many countries can be modeled by an appropriate equation. In Bangladesh, from 1970 to 2000, patterns of fertility changed according to the equation  $y = -0.11x + 6.45$ , where  $x$  is the time in years beginning in 1970 and  $y$  is the average number of children per woman. (Source: Lori Ashford, "World Population Highlights 2004," BRIDGE Population Reference Bureau, August 2004.)
- What number is  $f(20)$  and what does it represent?
  - What number is  $f'(20)$  and what does it represent?
24. **Birth rate:** Patterns of fertility changed in India from 1970 to 2000 according to the equation  $y = -0.068x + 5.22$ , where  $x$  is the number of years after 1970 and  $y$  is the average number of children per woman. (Source: Lori Ashford, "World Population Highlights 2004," BRIDGE Population Reference Bureau, August 2004.)
- What number is  $f(30)$  and what does it represent?
  - What number is  $f'(30)$  and what does it represent?

- 25. Birth rate:** In China, from 1964 to the present, the death rate has remained nearly constant at about 8 deaths per 1000 persons. However, the yearly birth rate, in births per 1000 people, has declined in most years according to the formula  $f(x) = -0.641x + 35.8$ , where  $x$  is the number of years since 1964. (Source: Nancy E. Riley, “China’s Population: New Trends and Challenges,” *Population Bulletin*, Vol. 20, No. 2, June 2004.)
- What number is  $f(30)$  and what does it represent?
  - What number is  $f'(30)$  and what does it represent?
- (Note: See Exercise 36 in Section 2.8 for a similar problem using a more accurate model than the linear model given here. Both models are based on the same data.)

 TECHNOLOGY

Use a graphing calculator in Exercises 26–29 to find the slope of  $f(x)$  at the given point. Sketch the graph of  $f(x)$  and the tangent line at the given point on your paper.

- $f(x) = \frac{4+2x}{\sqrt{x}}$ ; (16, 9)
- $f(x) = x^3$ ; (3, 27)
- $f(x) = 2 - 3x + x^2$ ; (1, 0)
- $f(x) = 10^x$ ; (2, 100)
- For the function  $f(x) = 4 - x - 2x^2$ , find a window including the point (0, 4) so that the graph of the function and the tangent at (0, 4) are indistinguishable.
- For the function  $f(x) = x^3$ , make a table with headings  $a$ ,  $f(a)$ , and  $f'(a)$ . Then substitute numbers using  $a = -1, 0, 1, 2, 3, 4$ . Give a formula for  $f'(x)$ .
- Locate (with a graphing calculator) the  $x$ - and  $y$ -coordinates of the lowest point on the graph  $f(x) = x^2 - 6x + 11$ . What is the slope at the lowest point?
- For the function  $y = x^2$  add a column to Table 3 to include the  $y$ -intercepts of the tangent line. What curiosity do you observe in the table?
- Find the **1n** button on your graphing calculator and sketch a graph of  $y = \ln x$  on your calculator using the window  $[-2, 8]$  by  $[-0.5, 2]$ . What is the slope at the point (1, 0)? Sketch the graph and tangent on your paper.
- On  $f(x) = \sqrt{x}$ , locate the  $x$ - and  $y$ -coordinates of the point at which the slope is exactly 1. (Hint: Find  $(a, \sqrt{a})$  so that  $f'(a) = 1$ .)
- A bacteria culture in a lab grows according to the formula  $y = 1600(2^t)$  where  $t$  is time in hours and  $y$  is the quantity of bacteria.
  - Interpret the meaning of  $f'(1)$ .
  - Determine  $f''(1)$  using a graphing calculator.
- Sketch  $f(x) = (x+10)(x-5)(x-10)$  on a graphing calculator. Give the window used.
  - Locate the points  $(a, f(a))$  for which  $f'(a) = 0$ .
  - What is the value of  $f'(2)$ ?

38. Sketch  $y = \frac{1}{x}$  on a graphing calculator. Find the  $x$ - and  $y$ -coordinates of any point with slope  $-25$ .
39. Suppose  $f(x) = 2x^2$ . Create a table of values for the slope of  $f'(x)$  (see Table 4). Guess a formula for  $f'(x)$ .

At the beginning of this section we listed a few other ways to denote the derivative. A more complete list of commonly used notations is as follows:

$$f'(x), y', \frac{dy}{dx}, \frac{d}{dx}f(x), f'_x, D_x(f(x)), \text{ and } f'.$$

### Example 6: Using Derivative Notation

Find  $D_x(h(x))$  where  $h(x) = \frac{18}{x^3}$ .

#### Solution

$$h(x) = \frac{18}{x^3} = 18x^{-\frac{2}{3}}$$

Rewrite the expression to be a polynomial-like function.

$$\begin{aligned} D_x(h(x)) &= D_x\left(18x^{-\frac{2}{3}}\right) = h'(x) = 18 \cdot \left(-\frac{2}{3} \cdot x^{-\frac{2}{3}-1}\right) \\ &= \frac{-18(2)}{3} x^{-\frac{5}{3}} \\ &= -12x^{-\frac{5}{3}} \end{aligned}$$

Use the Power Rule with  $c = 18$  and  $r = -\frac{2}{3}$  to find the derivative.

## 2.7 EXERCISES

### PRACTICE

In Exercises 1–10, use the definition of the derivative to find  $f'(x)$ .

1.  $f(x) = 10$

2.  $f(x) = -5x$

3.  $f(x) = -x + 1$

4.  $f(x) = 6x^2$

5.  $f(x) = x - x^2$

6.  $f(x) = \frac{1}{2}x^2 + 3x - 9$

7.  $f(x) = x^3 - 4$

8.  $f(x) = \frac{1}{3}x - x^3$

9.  $f(x) = -\frac{1}{x}$

10.  $f(x) = \frac{2}{x^2}$

Use the rules of differentiation learned so far to find the derivative for each of the functions in Exercises 11–32.

11.  $f(x) = 4$

12.  $f(x) = 3x$

13.  $f(x) = 7x - 2$

14.  $y = 12$

15.  $y = -x$

16.  $y = x + 3$

17.  $y = 4x^2$

19.  $y = \frac{7}{x}$

21.  $y = \frac{1}{2x^3}$

23.  $g(x) = 3\sqrt{x}$

25.  $h(t) = t^{2.3}$

27.  $f(x) = 3x^{0.8}$

29.  $f(u) = \frac{1}{\sqrt{u}}$

31.  $f(x) = -5x^{\frac{3}{4}}$

18.  $y = -\frac{8}{7}x^7$

20.  $y = \frac{4}{x^5}$

22.  $g(x) = \frac{4}{3x^2}$

24.  $h(x) = 2\sqrt[3]{x}$

26.  $h(t) = t^{-1.4}$

28.  $f(u) = 2u^{0.1}$

30.  $f(x) = \frac{2}{\sqrt[4]{x}}$

32.  $f(x) = 6x^{-\frac{2}{3}}$

## 2.8 EXERCISES

 PRACTICE

Use the various rules of differentiation to find the derivative for each of the functions in Exercises 1–10.

1.  $y = x^3 - 7x$

2.  $y = 4x^2 - 9x + 2$

3.  $y = 0.3x^2 - 4x + 6$

4.  $y = 120 + 8x - 0.2x^2$

5.  $y = x^3 - 6x^2 + 5x + 2$

6.  $y = \frac{1}{3}x^3 - \frac{1}{2}x^2 - 3x + 4$

7.  $y = 2x^{\frac{3}{2}} + 4x^{\frac{1}{2}} - 5$

8.  $y = 2x^{-\frac{2}{3}} + 3x^{\frac{1}{3}} + 7$

9.  $f(t) = 2t^{-\frac{1}{2}} + t^{\frac{1}{2}} + t$

10.  $f(x) = 3x^{-\frac{1}{3}} - 2x^{-\frac{1}{2}} + 1$

In Exercises 11–20, use algebraic techniques to rewrite each function as a sum or difference; then find the derivative.

11.  $y = (x+1)(2x-3)$

12.  $y = \sqrt{x}(2x^2 + x - 3)$

13.  $f(v) = v^{\frac{3}{2}}(v^2 + 2v - 1)$

14.  $f(v) = v^{\frac{1}{3}}(6 - 4v + v^2)$

15.  $f(x) = \frac{x^4 + 5x^3}{x^2}$

16.  $f(x) = \frac{6x^2 + 1}{x^3}$

17.  $g(t) = \frac{t-2}{\sqrt{t}}$

18.  $g(t) = \frac{t^2 + 3}{\sqrt[3]{t}}$

19.  $g(x) = \frac{4x + 5x^{\frac{1}{2}} - 1}{\sqrt{x}}$

20.  $g(x) = \frac{3\sqrt{x} + 4x - 2}{x^2}$

In Exercises 21–26, confirm your results with a graphing calculator.

21. Let  $f(x) = x^3 + 2x - 4$ .

- Find the slope of the tangent line at  $x = -1$ .
- Find the equation of the tangent line at  $x = -1$ .

22. Let  $f(x) = 2x^3 - x^2 - 3x$ .

- Find the slope of the tangent line at  $x = 2$ .
- Find the equation of the tangent line at  $x = 2$ .

23. Let  $g(x) = x^2 + 6x + 5$ .

- Find the slopes of the tangent lines at  $x = -1$ ,  $x = -3$ , and  $x = -4$ .
- Find the equations of the tangent lines at  $x = -1$ ,  $x = -3$ , and  $x = -4$ .
- Sketch the graphs of the curve and the three tangent lines.

24. Let  $g(x) = x^2 - 8x + 12$ .
- Find the slopes of the tangent lines at  $x = 2$ ,  $x = 4$ , and  $x = 5$ .
  - Find the equations of the tangent lines at  $x = 2$ ,  $x = 4$ , and  $x = 5$ .
  - Sketch the graphs of the curve and the three tangent lines.
25. Let  $f(x) = 8 - x^2$ .
- Find the slopes of the tangent lines at  $x = -2$ ,  $x = 0$ , and  $x = 1$ .
  - Find the equations of the tangent lines at  $x = -2$ ,  $x = 0$ , and  $x = 1$ .
  - Sketch the graphs of the curve and the three tangent lines.
26. Let  $f(x) = 10 - 3x - x^2$ .
- Find the slopes of the tangent lines at  $x = -3$ ,  $x = -2$ , and  $x = 0$ .
  - Find the equations of the tangent lines at  $x = -3$ ,  $x = -2$ , and  $x = 0$ .
  - Sketch the graphs of the curve and the three tangent lines.

### APPLICATIONS

27. **Velocity of a rocket:** A model rocket is fired vertically upward. The height after  $t$  seconds is  $s(t) = 192t - 16t^2$  feet.
- Find the velocity at  $t = 0$  seconds.
  - Find the velocity at  $t = 4$  seconds.
  - When will the velocity be zero?
28. **Velocity of a particle:** A particle moving in a straight line is at a distance of  $s(t) = 2.5t^2 + 18t$  feet from its starting point after  $t$  seconds, where  $0 \leq t \leq 12$ .
- Find the velocity at  $t = 6$ .
  - Find the velocity at  $t = 9$ .
29. **Population:** A city's population  $t$  years from now can be estimated from the formula  $P(t) = 9000 + 500t - 72\sqrt{t}$ .
- Find the rate at which the city is growing after 4 years.
  - Find the rate at which the city is growing after 9 years.
30. **Cost:** The total cost of producing  $x$  units of a product is given by  $C(x) = 4000 + 25x - 0.2x^2$  dollars, where  $0 \leq x \leq 50$ .
- Find the rate of change in the cost when  $x = 10$ .
  - Find the rate of change in the cost when  $x = 30$ .
31. **Fuel consumption:** When a factory operates from 6:00 a.m. to 6:00 p.m., its total fuel consumption varies according to the formula  $f(t) = 0.9t^2 - 0.3t^{0.5} + 20$ , where  $t$  is the time in hours after 6:00 a.m. and  $f(t)$  is number of barrels of fuel oil.
- How much fuel oil is consumed by noon?
  - What is the rate of consumption of fuel at 10:00 a.m.?
  - What is the average rate of consumption from 6:00 a.m. to 2:00 p.m.?
32. **Population:** The population of bacteria in a lab experiment for BIOL 403 at Nevada Tech is given by  $f(x) = 2.2x^{1.5} - 0.7x + 2$ , where  $x$  is the time in hours after 2:00 p.m. and  $f(x)$  is population in suitable units.
- What is the population at 2:00 p.m.?
  - The lab is over at 4:00 p.m. What is the new population of bacteria?
  - What is the average rate of change of bacteria from 2:00 p.m. to 4:00 p.m.?
  - What is the instantaneous rate of change of bacteria at 3:00 p.m.?

- 33. Electrical charge:** The electrical charge on a new cell phone declines according to the formula  $C(t) = 15 - 0.1t^2 - 0.5t$ , where  $t$  is the time in hours following a full charge and  $C(t)$  is a measure of the charge.
- To the nearest hour, how long does it take for the charge to be fully depleted?
  - What is the instantaneous rate of change, in charge units per hour, at  $t = 4$ ?
  - What is the average rate of change from  $t = 0$  to  $t = 4$ ?
- 34. Spreading a rumor:** The number of college students at Salis Technical College who have not heard a new rumor is approximated by the formula  $N(x) = 300(1 - 0.004x^2)$ , where  $x$  is the number of days following the start of a new rumor.
- How many days does it take for 90 percent of the students to hear the rumor?
  - What is the instantaneous rate of change in students after one day? Interpret the meaning of this number.
  - Why is the slope negative in this exercise?
- 35. Birth rate:** The fertility decline in many countries can be modeled by a quadratic equation. In China, from the late 1960s to the present, the number of births per woman has declined according to the formula  $f(x) = 0.00675x^2 - 0.3215x + 5.585$ , where  $x$  is the number of years after 1969. (Source: Nancy E. Riley, "China's Population: New Trends and Challenges," *Population Bulletin*, Vol. 20, No. 2, June 2004.)
- What was the number of births per woman in 1969?
  - What was the number of births per woman in 1999?
  - What was the rate of change of this fertility rate in 1979?
- 36. Birth rate:** In China, from 1964 to the present, the death rate has remained nearly constant at approximately 8 deaths per 1000 people. The yearly birth rate, in births per 1000 people, has declined in most years according to the formula  $f(x) = -0.00191x^3 + 0.134x^2 - 3.16x + 44.5$ , where  $x$  is the number of years since 1964. (Source: Nancy E. Riley, "China's Population: New Trends and Challenges," *Population Bulletin*, Vol. 20, No. 2, June 2004.)
- What number is  $f(30)$  and what does it represent?
  - What number is  $f'(30)$  and what does it represent?
  - In what year, according to the model, did the number of new births equal the number of deaths?
- 37. Population growth:** The percentage of older persons in China (age 60 and over) has grown since the 1950s according to the formula  $f(x) = 0.003727x^2 - 0.105x + 7.063$ , where  $x$  is the number of years since 1953. (Source: Nancy E. Riley, "China's Population: New Trends and Challenges," *Population Bulletin*, Vol. 20, No. 2, June 2004.)
- What was the percentage of older persons in China in 1953?
  - What is the percentage of older persons projected to be in the year 2025?
  - At what rate was the percentage changing in 2000?

- 38. Population growth:** The population in billions of people in the lesser developed countries has varied according to the formula  $P(x) = \frac{4.953}{10^4}x^2 - 0.007352x + 1.7748$ , where  $x$  is the number of years since 1900. (Source: Population Reference Bureau, "Transition's in World Population," *Population Bulletin*, Vol. 59, No. 1, 5, March 2004.)
- What was the population in 1950?
  - At what rate was the population changing in 1950?
  - What population was projected for 2020 in these countries?
- 39. Death rate:** The death rate in Mexico has varied since 1920 according to the formula  $M(x) = -\frac{2.076}{10^4}x^3 + 0.033x^2 - 1.785x + 43.07$ , where  $x$  is the number of years since 1920. (Source: Population Reference Bureau, "Transition's in World Population," *Population Bulletin*, Vol. 59, No. 1, 5, March 2004.)
- What was the death rate in 1950?
  - At what rate was the death rate changing in 1950?
  - What was the death rate in 2000?
  - In what year did the formula predict that no one would die?
- 40. Birth rate:** The function  $f(x) = 0.00375x^2 - 0.2355x + 5.595$  gives the average number of births per woman in Thailand where  $x$  denotes the number of years since 1970. (Source: Lori Ashford, "World Population Highlights 2004," BRIDGE Population Reference Bureau, August 2004.)
- What number is  $f(10)$  and what does it represent?
  - What number is  $f'(10)$  and what does it represent?
- 41. Birth rate:** In Argentina, from 1970 to 2000, the average number of births per woman was given by the function  $f(x) = -0.001x^2 + 0.014x + 3.14$ , where  $x$  is the number of years after 1970. (Source: Lori Ashford, "World Population Highlights 2004," BRIDGE Population Reference Bureau, August 2004.)
- What number is  $f(30)$  and what does it represent?
  - What number is  $f'(30)$  and what does it represent?

### Example 5: Marginal Propensity

If the marginal propensity to save is  $S'(x) = 0.02x$ , what is the marginal propensity to consume?

### Solution

$$\begin{aligned} C'(x) &= 1 - S'(x) \\ &= 1 - 0.02x \end{aligned}$$

We replace  $S'(x)$  with  $0.02x$ .

## 2.9 EXERCISES

### PRACTICE

In Exercises 1–10, create an appropriate function of the type indicated.

- The cost of producing  $x$  leather belts is given by  $C(x) = 220 + 0.4x$ . Determine the average cost function.
- The cost of manufacturing a certain class of screws for wall hangers is given by  $C(x) = 800 + 0.0005x + 0.00002x^2$ . Determine the average cost function.
- A vendor charges \$3 for a hot dog. What is the demand function? What is the revenue function?
- The Knoll Industrial Supply Company charges for 55-gallon drums using the demand function  $p(x) = 22.5 - 0.5x$ . What is the revenue function?
- A supplier of souvenir T-shirts charges street vendors for each order based on a setup fee of \$50 and an item charge of \$1.15 per T-shirt. What is the cost function for the vendor?
- A supplier of souvenir T-shirts has setup costs of \$25 and shirts cost \$0.40 each. What is the cost function?
- The answer to Exercise 5 is also a revenue function for the supplier of T-shirts. Using the answers to Exercises 5 and 6, determine a profit function for the supplier of T-shirts.
- For the supplier in Exercise 6, what is the average cost function?
- A department store's cost estimate for a line of rocker-recliner chairs is given by  $C(x) = 100 + 150x$ . The store sells them for \$450 each.
  - What is the average cost function?
  - What is the demand function?
  - What is the revenue function?
  - What is the profit function?

10. A shoe store estimates a certain line of dress shoes has costs given by  $C(x) = 1500 + 30x + 0.05x^2$ . The store charges \$75 per pair.
- What is the average cost function?
  - What is the demand function?
  - What is the revenue function?
  - What is the profit function?
11. Suppose that total national consumption is given by a function  $C(x) = 200 - 0.6x - 0.05x^{0.6}$ , where  $x$  is the total national income.
- Determine the marginal propensity to consume.
  - Determine the marginal propensity to save.
12. If the marginal propensity to save of a certain country is given by  $S'(x) = 0.4x + 0.3$ , determine the marginal propensity to consume.
13. The average cost  $\bar{C}(x)$  of a product is  $\frac{C(x)}{x}$ , where  $C(x)$  is the total cost function.
- What is the average cost function if its total cost function is  $C(x) = 30 + 2x + 0.003x^2$ ?
  - What is the rate of change of average cost?
  - What value of  $x$  results in a minimum average cost?
14. The average cost of a product is given by  $A(x) = 20x^{-1} + 3$ .
- Determine the cost function for the product.
  - Determine the marginal cost function.

### APPLICATIONS

15. The weekly cost of producing  $x$  electric drills is given by the function

$$C(x) = 2400 + 28x + 0.25x^2.$$

- Find  $C(10)$ ,  $C(20)$ , and  $C(30)$ .
  - Find the marginal cost function.
  - Find  $C'(10)$ ,  $C'(20)$ , and  $C'(30)$ .
  - Find the average cost function and the marginal average cost function.
  - Find the marginal average cost when  $x = 10$ ,  $x = 20$ , and  $x = 30$ .
16. The total cost function for producing  $x$  units of a product is given by

$$C(x) = \frac{1}{3}x^3 - \frac{1}{2}x^2 + 7x + 18.$$

- Find  $C(3)$ ,  $C(4)$ , and  $C(6)$ .
- Find the marginal cost function.
- Find  $C'(3)$ ,  $C'(4)$ , and  $C'(6)$ .
- Find the average cost function and the marginal average cost function.
- Find the marginal average cost when  $x = 3$ ,  $x = 4$ , and  $x = 6$ .

17. The total cost of producing  $x$  units of a commodity is given by

$$C(x) = 60 + 10x - 0.5x^2.$$

- Find  $C(4)$ ,  $C(6)$ , and  $C(9)$ .
- Find the marginal cost function.
- Find  $C'(4)$ ,  $C'(6)$ , and  $C'(9)$ .
- Find the average cost function.
- Find the marginal average cost when  $x = 4$ ,  $x = 6$ , and  $x = 9$ .

18. The total cost of producing  $x$  wireless speakers is given by the function  $C(x) = 300 + 24x - 0.4x^2 + 0.1x^3$ .
- Find  $C(2)$ ,  $C(3)$ , and  $C(5)$ .
  - Find the marginal cost function.
  - Find  $C'(2)$ ,  $C'(3)$ , and  $C'(5)$ .
  - Find the average cost function and the marginal average cost function.
  - Find the marginal average cost if  $x = 4$ .
19. A manufacturer has determined that the revenue from the sale of  $x$  cell phones is given by  $R(x) = 94x - 0.03x^2$  dollars. The cost of producing  $x$  cell phones is  $C(x) = 10,800 + 34x$  dollars.
- Find the profit function  $P(x)$ .
  - Find  $P(200)$ ,  $P(400)$ , and  $P(600)$ .
  - Find the marginal profit function  $P'(x)$ .
  - Find  $P'(200)$ ,  $P'(400)$ , and  $P'(600)$ .
  - Find any break-even points.
20. The revenue from the sale of  $x$  fire extinguishers is estimated to be  $R(x) = 54x - 0.4x^2$  dollars. The total cost of producing  $x$  fire extinguishers is  $C(x) = 400 + 30x - 0.2x^2$  dollars.
- Find the profit function  $P(x)$ .
  - Find  $P(20)$ ,  $P(40)$ , and  $P(60)$ .
  - Find the marginal profit function  $P'(x)$ .
  - Find  $P'(20)$ ,  $P'(40)$ , and  $P'(60)$ .
  - Find any break-even points.
21. A company that produces and sells compact refrigerators has found that the revenue from the sale of  $x$  refrigerators is  $R(x) = 100x - 0.1x^2$  dollars. The cost function is given by  $C(x) = 2070 + 25x + 0.1x^2$  dollars.
- Find the profit function  $P(x)$ .
  - Find  $P(60)$ ,  $P(80)$ , and  $P(100)$ .
  - Find the marginal profit function  $P'(x)$ .
  - Find  $P'(60)$ ,  $P'(80)$ , and  $P'(100)$ .
  - Find any break-even points.
22. A manufacturer has determined that the cost and the revenue of producing and selling  $x$  telescopes are  $C(x) = x^2 + 20x + 1050$  dollars and  $R(x) = 140x - 0.5x^2$  dollars, respectively.
- Find the profit function  $P(x)$ .
  - Find  $P(30)$ ,  $P(35)$ , and  $P(40)$ .
  - Find the marginal profit function  $P'(x)$ .
  - Find  $P'(30)$ ,  $P'(35)$ , and  $P'(40)$ .
  - Find any break-even points.

23. The owner of a leather craft shop has determined that he can sell  $x$  attaché cases if the price is  $p = D(x) = 46 + 0.25x$  dollars. The total cost for these cases is  $C(x) = 0.15x^2 + 6x + 190$  dollars.
- Find the revenue function  $R(x)$ .
  - Find the profit function  $P(x)$ .
  - Find  $P(25)$ ,  $P(30)$ , and  $P(40)$ .
  - Find the marginal profit function  $P'(x)$ .
  - Find  $P'(25)$ ,  $P'(30)$ , and  $P'(40)$ .
24. A firm can sell  $x$  items of a product when the price is  $p = D(x) = 3.00 - 0.001x$  dollars. The total production costs are  $C(x) = 0.002x^2 + 0.72x + 260$  dollars.
- Find the revenue function  $R(x)$ .
  - Find the profit function  $P(x)$ .
  - Find  $P(300)$ ,  $P(375)$ , and  $P(400)$ .
  - Find the marginal profit function  $P'(x)$ .
  - Find  $P'(300)$ ,  $P'(375)$ , and  $P'(400)$ .
25. A local publishing company prints a special magazine each month. It has been determined that  $x$  magazines can be sold monthly when the price is  $p = D(x) = 5.50 - 0.0004x$ . The total cost of producing the magazine is  $C(x) = 0.0002x^2 + x + 4650$  dollars.
- Find the revenue function  $R(x)$ .
  - Find the profit function  $P(x)$ .
  - Find  $P(3000)$ ,  $P(3500)$ , and  $P(4000)$ .
  - Find the marginal profit function  $P'(x)$ .
  - Find  $P'(3000)$ ,  $P'(3500)$ , and  $P'(4000)$ .
26. A sales representative for a company that produces skateboards can sell  $x$  units of their deluxe model if the price is  $p = D(x) = 79.9 - 0.03x$  dollars. The total cost for these skateboards is given by  $C(x) = 0.08x^2 + 5.1x + 5800$  dollars.
- Find the revenue function  $R(x)$ .
  - Find the profit function  $P(x)$ .
  - Find  $P(320)$ ,  $P(340)$ , and  $P(350)$ .
  - Find the marginal profit function  $P'(x)$ .
  - Find  $P'(320)$ ,  $P'(340)$ , and  $P'(350)$ .
27. A certain model car has a valuation in dollars given by the formula  $f(x) = 12,519.3 - 1391.1x$ , for  $0 \leq x \leq 7$ , where  $x$  is the age of the car in years.  $x = 0$  corresponds to this calendar year.
- What is  $f(0)$ ? Interpret this number.
  - What is the marginal valuation? Interpret this number.
28. Based on averaging results at a certain state college, a relationship between grades and SAT scores was found to be  $f(s) = 1.36 + 0.00141s$ , where  $s$  is a student's SAT score and  $f(s)$  is the student's graduating GPA (GPA based on 4.0 maximum score).
- What is the expected GPA for a student with an SAT score of 1000?
  - What is the marginal GPA? Interpret this number.

Exercises 29–31 deal with projections of world population based on estimates of fertility around the world. Use the following background information:

The Total Fertility Rate (TFR) is the average number of children a woman will have. The United Nations projects world population according to assumptions about TFR values. In general, lower values promote economic well-being and lower world population. (Source: Population Reference Bureau, “Transitions in World Population,” *Population Bulletin*, Vol. 59, No. 1, 36, March 2004.)

**29. Total fertility rate:** Using a TFR of 1.5, the UN projects total world population, in billions, will be modeled by  $F(t)$  where  $t$  is the number of years after 2000 and

$$F \text{ is the function } F(t) = -\frac{2.1}{10^6}t^4 + \frac{1.6}{10^4}t^3 - 0.00457t^2 + 0.0994t + 6.03.$$

- Give the marginal population function  $F'(t)$ .
- Determine the estimate of world population in 2030.
- What is the marginal population in 2030? Interpret this number.

**30. Total fertility rate:** Using a TFR of 2.0, the UN projects total world population, in billions, will be modeled by  $G(t)$  where  $t$  is the number of years after 2000 and

$$G \text{ is the function } G(t) = -\frac{2.1}{10^6}t^4 + \frac{1.66}{10^4}t^3 - 0.0045t^2 + 0.113t + 6.03.$$

- Give the marginal population function  $G'(t)$ .
- Determine the estimate of world population in 2030.
- What is the marginal population in 2030? Interpret this number.

**31. Total fertility rate:** Using a TFR of 2.5, the UN projects total world population, in billions, will be modeled by  $H(t)$  where  $t$  is the number of years after 2000 and

$$H \text{ is the function } H(t) = -\frac{2.6}{10^6}t^4 + \frac{1.87}{10^4}t^3 - 0.00396t^2 + 0.116t + 6.05.$$

- Give the marginal population function  $H'(t)$ .
- Determine the estimate of world population in 2030.
- What is the marginal population in 2030? Interpret this number.



### WRITING & THINKING

**32.** An economics professor claimed that the average cost was a minimum if the average cost equaled the marginal cost. Do you agree? Explain why or why not.

**33.** “The average revenue  $\frac{R(x)}{x}$  is not usually studied in the context of business economics.” Argue for or against this statement.

**⚠ CAUTION**

If the rules of differentiation have been followed, then an answer may be correct even though it does not “look like” the answer given. Be sure to check with your instructor to see how much algebraic simplification is expected and whether or not one form is preferred over another.

**3.1 EXERCISES****💡 PRACTICE**

In Exercises 1–5, find  $f'(x)$  two ways: (1) multiply the factors first, then find the derivative, and (2) use the Product Rule.

1.  $f(x) = x^2(1 + 3x - 2x^2)$

2.  $f(x) = (x + 3)(x - 1)$

3.  $f(x) = x^{\frac{1}{2}}(1 + 3x^2)$

4.  $f(x) = x^{\frac{1}{2}}(1 + x^{\frac{1}{2}} - x^{\frac{3}{2}})$

5.  $f(x) = (2x + 3)(2x - 3)$

In Exercises 6–10, find  $g'(x)$  two ways: (1) divide the factors first, then find the derivative, and (2) use the Quotient Rule and simplify the answer.

6.  $g(x) = \frac{1 + 5x + x^2}{x}$

7.  $g(x) = \frac{2 + \sqrt{x}}{\sqrt{x}}$

8.  $g(x) = \frac{x^2 + 1}{x^5}$

9.  $g(x) = \frac{30x^2 - 10x^6}{5x}$

10.  $g(x) = \frac{3x^{\frac{1}{2}} - 5x^{\frac{3}{2}} + 7x^{\frac{5}{2}} - 9x^{\frac{7}{2}}}{x^{\frac{1}{2}}}$

In Exercises 11–34, use the Product Rule or Quotient Rule to find the derivative of each of the functions. Simplify your answers.

11.  $f(x) = x^3(x^2 + 5)$

12.  $f(x) = x^5(2x - x^3)$

13.  $f(t) = t^{\frac{1}{2}}(4t + 3)$

14.  $f(t) = t^{\frac{2}{3}}(4t^2 + 1)$

15.  $y = x^2\left(\sqrt{x} + \frac{1}{\sqrt{x}}\right)$

16.  $y = x^{-2}\left(3x + x^{\frac{1}{3}}\right)$

17.  $g(u) = (2u^2 + 3)(5 - 3u)$

18.  $g(u) = (3u^2 - 8)(u^2 + u)$

19.  $g(t) = \left(5 + \frac{1}{t}\right)\left(t^2 + \frac{1}{5}\right)$

20.  $f(t) = \left(1 - \frac{3}{t^2}\right)(2t^2 + t - 1)$

21.  $f(x) = \frac{3x}{x + 6}$

22.  $f(x) = \frac{7x^2}{2x - 1}$

23.  $f(x) = \frac{x + 8}{x - 7}$

24.  $f(x) = \frac{x^2 + 2x - 3}{x + 2}$

25.  $y = \frac{x^3 - 5}{x^2 + 1}$

26.  $y = \frac{2x^2 + 3x}{x^3 + 6}$

$$27. g(x) = \frac{\sqrt{x}}{x+9} \qquad 28. g(x) = \frac{6\sqrt{x}}{3x-4} \qquad 29. f(u) = \frac{u^2}{\sqrt{u}+1}$$

$$30. f(u) = \frac{7}{1-\sqrt[3]{u}} \qquad 31. f(t) = \frac{4-\sqrt{t}}{t^2+3} \qquad 32. f(t) = \frac{3-t}{4-5\sqrt{t}}$$

$$33. f(x) = \frac{x^2-5x}{1+2\sqrt[3]{x}} \qquad 34. f(x) = \frac{x(1+3\sqrt{x})}{\sqrt{x}+6}$$

In Exercises 35–44, you are given that  $f(x)$  and  $g(x)$  are differentiable functions and that  $f(2) = 3$ ,  $f'(2) = -1$ ,  $g(2) = -11$ , and  $g'(2) = 6$ . In each exercise, find the value of  $h'(2)$ .

$$35. h(x) = x \cdot f(x) \qquad 36. h(x) = \frac{f(x)}{2x+1}$$

$$37. h(x) = \frac{f(x)+3x}{f(x)-3x} \qquad 38. h(x) = \frac{g(x)}{f(x)}$$

$$39. h(x) = \frac{g(x)}{3x+10} \qquad 40. h(x) = (3x+5) \cdot f(x)$$

$$41. h(x) = \frac{16x+1}{f(x)-11x+1} \qquad 42. h(x) = f(x) \cdot g(x)$$

$$43. h(x) = \frac{f(x)}{g(x)} \qquad 44. h(x) = g(x) \cdot (1+3x)$$

In Exercises 45–50, find the equation of the line tangent to the graph of  $f(x)$  at the given point.

$$45. f(x) = \left(x + 5x^{\frac{1}{2}}\right)(6x^2 - 12x + 2); (4, 700)$$

$$46. f(x) = \frac{(11x^2 - 3x + 2)}{x^2 + 1}; (1, 5)$$

$$47. f(x) = \frac{2-3x}{5+2x}; (0, 0.4)$$

$$48. f(x) = (x^5 - 5)(x^3 - x - 1); (0, 5)$$

$$49. f(x) = \frac{20}{17x+3}; (1, 1)$$

$$50. f(x) = \frac{\sqrt{x}+2}{x^2-1}; \left(9, \frac{1}{16}\right)$$

51. Given  $f(x) = (1-x)(16-x^2)$ , find the  $(x, y)$ -coordinates on the graph where the tangent line is horizontal.

52. Given  $g(x) = (x-10)(x^2+2x+1)$ , find any  $(x, y)$ -coordinates on  $g(x)$  for which the tangent line is horizontal.

53. Find any point or points on the graph of  $y = (x-5)(x+10)$  so that the slope equals 25. Sketch a graph of  $y$  and the tangent line or lines.

54. Find any point or points on the graph of  $G(x) = (2x + 1)(x - 3)$  so that the slope is  $-20$ . Sketch a graph of  $G$  and the tangent line or lines.
55. Sketch a graph of  $F(x) = \frac{30x}{2x^2 + 5}$  on the  $x$ -interval  $[-5, 10]$ . Determine the  $(x, y)$ -coordinates of any point with a horizontal tangent line, and sketch this (or these) horizontal tangent(s). Round to the nearest hundredth.

### APPLICATIONS

56. **Bacterial growth:** It is estimated that the population of a bacterial culture after  $t$  hours is approximately  $N(t) = \frac{t^2 - 2t}{3\sqrt{t} + 2}$ , where  $N(t)$  is in thousands and  $2 \leq t \leq 10$ . Find the rate of growth after 4 hours.
57. **Marginal revenue:** The demand function for a particular item is given by  $D(x) = \frac{115}{3x + 1}$ . Find the marginal revenue when  $x = 3$ .
58. **Marginal profit:** The profit from the sale of  $x$  items is given by  $P(x) = (2 - 0.5x)(0.5x - 5)$ , where  $P(x)$  is in hundreds of dollars and  $2 \leq x \leq 10$ . Find the marginal profit when  $x = 5$ .
59. **Marginal cost:** The cost of producing  $x$  items of a product is given by  $C(x) = (0.1x + 100)(0.1x + 20) - 600$ . Find the marginal cost when  $x = 60$ .
60. **Velocity of a particle:** A particle is moving slowly along a line. Its position after  $t$  seconds is  $S(t) = \frac{t}{t^2 + 4}$  feet. Find the velocity when the particle has been moving for 3 seconds.
61. **Population growth:** It is estimated that  $t$  years from now the population of a city will be  $P(t) = (0.6t - 7)(0.5t + 6) + 85$  in thousands. How fast will the population be growing in 10 years?

To find how fast this measure was changing in 1988 (8 years since 1980), evaluate the derivative for  $t = 8$ .

$$P'(8) = \frac{8^3 + 72 \cdot 8}{(8^2 + 36)^{\frac{3}{2}}} = \frac{512 + 576}{(100)^{\frac{3}{2}}} = \frac{1088}{1000} = 1.088$$

In 1988, the air pollution measure was increasing at a rate of 1.088 units per year.

## 3.2 EXERCISES

### PRACTICE

Find the derivative for each function given in Exercises 1–40 and simplify your answer.

1.  $f(x) = (2x - 5)^4$

2.  $f(x) = (7x + 2)^3$

3.  $f(x) = (1 - 4x)^3$

4.  $f(x) = (3 - 5x)^5$

5.  $g(x) = (x^2 + 4)^{-2}$

6.  $g(x) = (x^2 - 8)^{-1}$

7.  $h(t) = (2t^2 + 3t)^{-3}$

8.  $h(t) = (4t^2 - t)^{-2}$

9.  $y = (2x^2 + 5x - 7)^2$

10.  $y = (4x^2 + 9x - 3)^3$

11.  $y = (x^3 + 1)^{\frac{1}{2}}$

12.  $y = (2x^3 - 5)^{\frac{1}{3}}$

13.  $y = \sqrt[3]{4x^2 + 1}$

14.  $y = \sqrt{7 + 4x^2}$

15.  $y = \sqrt[4]{1 - 2x^3}$

16.  $y = \sqrt[3]{5x^3 - 4}$

17.  $f(t) = 5t(t^3 + 3)^4$

18.  $f(x) = -7x(x^4 - 2)^3$

19.  $f(x) = 2x^3(x^2 - 8)^3$

20.  $f(t) = t(4 - 3t^2)^2$

21.  $g(x) = \frac{1}{\sqrt{x^2 - 6}}$

22.  $g(x) = \frac{5}{\sqrt{x^3 + 4}}$

23.  $g(t) = \frac{t}{\sqrt{t^2 + 8}}$

24.  $g(x) = \frac{x^2}{\sqrt[3]{x^2 + 6}}$

25.  $h(x) = \frac{\sqrt[3]{2x + 3}}{x^2}$

26.  $h(x) = \frac{\sqrt{5x - 2}}{x^3}$

27.  $y = (2x + 1)\sqrt{3x - 4}$

28.  $y = (4x + 3)\sqrt{x^2 + 3}$

29.  $y = (3x - 2)^2(5x + 1)^{-2}$

30.  $y = (2x + 7)^3(3x + 1)^{-4}$

31.  $f(t) = \frac{5t + 1}{(t - 1)^{\frac{2}{3}}}$

32.  $f(t) = \frac{t^2 + t + 1}{\sqrt{t^4 - 1}}$

33.  $g(t) = \left(\frac{2t + 5}{t + 1}\right)^3$

34.  $g(t) = \left(\frac{5t + 4}{t^2 - 3}\right)^4$

35.  $y = \left(\frac{x + 3}{4 - 2x}\right)^{\frac{1}{2}}$

36.  $y = \left(\frac{x^2}{4x + 1}\right)^{\frac{1}{3}}$

37.  $y = \sqrt{\frac{x + 2}{3x - 1}}$

38.  $y = \sqrt{\frac{x^2 + 6}{x^3}}$

39.  $y = \frac{x^2 + x}{\sqrt{7-2x}}$

40.  $y = \frac{(x^2 + 2)^2}{\sqrt{5x-3}}$

In Exercises 41–50, find  $\frac{dy}{du}$ ,  $\frac{du}{dx}$ , and  $\frac{dy}{dx}$ . Then evaluate  $\frac{dy}{dx}$  for the given value of  $x$ .

41.  $y = u^2 + 2$ ,  $u = 3x^2 + 1$ ;  $x = -1$

42.  $y = \sqrt{u+4}$ ,  $u = x^2 + x - 1$ ;  $x = 2$

43.  $y = \frac{1}{u^2}$ ,  $u = 2x^3 - 3x + 3$ ;  $x = 1$

44.  $y = \sqrt[3]{u}$ ,  $u = 2x^3 - 4x$ ;  $x = 2$

45.  $y = u^{\frac{3}{2}}$ ,  $u = x^3 - 2x^2$ ;  $x = 3$

46.  $y = \frac{1}{u^3}$ ,  $u = 3x + 1$ ;  $x = 1$

47.  $y = \sqrt[3]{u}$ ,  $u = 7x^2 + 1$ ;  $x = -3$

48.  $y = u^2 + 3u + 4$ ,  $u = x^3 - 5x - 2$ ;  $x = -2$

49.  $y = 2u^2 - 5u + 3$ ,  $u = 5x + 6$ ;  $x = 2$

50.  $y = 2u^3 - 3u + 1$ ,  $u = x^3 + 8$ ;  $x = 1$

In Exercises 51–56, use the given information to find  $h'(2)$ :  $f(2) = 3$ ,  $f'(2) = -1$ ,  $g(2) = 4$ ,  $g'(2) = 10$ ,  $g(3) = 8$ , and  $g'(3) = 7$ .

51.  $h(x) = (f(x) + 1)^3$

52.  $h(x) = \left(\frac{f(x)}{g(x)}\right)^2$

53.  $h(x) = g(f(x))$

54.  $h(x) = \sqrt{f(x) + g(x)}$

55.  $h(x) = (g(x))^3$

56.  $h(x) = (2 + 3 \cdot f(x))(g(x))^3$

Determine the equation of the tangent line for  $f(x)$  at the  $x$ -value indicated in Exercises 57–60.

57.  $f(x) = (3x - 1)^3$ ;  $x = 1$

58.  $f(x) = \left(\frac{x^2 + 1}{x + 1}\right)^3$ ;  $x = 2$

59.  $f(x) = (3x^2 + 2x + 8)^{\frac{1}{2}}$ ;  $x = 4$

60.  $f(x) = \sqrt{10x + 1}$ ;  $x = 8$

### APPLICATIONS

**61. Marginal revenue:** A dealer of microwave ovens estimates that he can sell  $x$  ovens per month when the demand function (price) is  $p = D(x) = 20\sqrt{280 - 4x}$  dollars.

- Find the revenue function  $R(x)$ .
- Find  $R(21)$ .
- Find the marginal revenue function  $R'(x)$ .
- Find  $R'(21)$ .

- 62. Marginal revenue:** The demand function (price) for a particular product is given by  $D(x) = 8\sqrt{25 - 5x + 0.25x^2}$  dollars, where  $x$  is the number of units (in hundreds) sold.
- Find the revenue function  $R(x)$ .
  - Find  $R(2)$ .
  - Find the marginal revenue function  $R'(x)$ .
  - Find  $R'(2)$ .
- 63. Population growth:** It is estimated that  $t$  years from now the population of Castle City will be  $P(t) = 10(40 + 2t)^2 - 1600t$ .
- What will the population be in 8 years?
  - Find the rate of change in population in 8 years.
- 64. Air pollution:** It is estimated that  $t$  years from now the level of air pollution in Bohrberg will be  $P(t) = \frac{0.6\sqrt{8t^2 + 11t + 60}}{(t+1)^2}$  parts per million. Find the rate of change in the pollution level in 7 years.
- 65. Pollution:** After a sewage spill, the level of pollution in San Remo Bay is estimated by  $P(t) = \frac{200t^2}{\sqrt{t^2 + 11}}$ , where  $t$  is the time in days since the spill occurred. How fast is the level changing after 5 days? Round to the nearest whole number.
- 66. Bacterial growth:** It is estimated that in  $t$  hours the population of bacteria in a culture will be  $P(t) = \frac{8000}{\sqrt{8 - 0.5t}}$ .
- What will be the population in 8 hours?
  - Find the rate of change in the population in 8 hours.
- 67. Rate of change of cost:** A manufacturer of vacuum cleaners estimates that the total cost of producing  $x$  vacuum cleaners is given by  $C(x) = -0.5x^2 + 56x + 800$  dollars. Records show that after  $t$  hours on a typical day, the number of units produced is given by  $x = 5\sqrt{t^2 + 5t}$ . Find the rate of change of total cost with respect to time at the end of
- 4 hours.
  - 5 hours.
- 68. Rate of change of profit:** A manufacturer has determined that the weekly profit from the sale of  $x$  items is given by  $P(x) = -x^2 + 280x - 4000$  dollars. It is estimated that after  $t$  days in any week,  $x = 0.5t^2 + 5t$  items will have been produced. Find the rate of change of profit with respect to time at the end of
- 4 days.
  - 5 days.

- 69. Pollution:** Studies show that the average level of certain pollutants in the air is given by  $L = 1 + 0.2x + 0.001x^2$  parts per million when the population is  $x$  thousand people. It is estimated that  $t$  years from now the population will be  $x = \frac{200}{\sqrt{7 - 0.5t}}$  in thousands. Find the rate of change of the level of pollutants after
- 6 years.
  - 12 years.
- 70. Security costs:** The annual cost for campus security is given by  $C(x) = 3x^2 - 32x + 16$  in thousands of dollars. It is estimated that the enrollment in  $t$  years will be  $x = 16 + 0.5t + 0.02t^2$  in thousands. Find the rate of change in security costs after
- 3 years.
  - 4 years.
- 71. Baseball attendance:** The average home attendance per week at a Class AA baseball park varied according to the formula  $N(t) = (3 + 0.2t)^{\frac{1}{2}}$ , where  $t$  is the number of weeks into the season ( $0 \leq t \leq 12$ ) and  $N$  is in thousands of persons.
- What was the attendance during the first week into the season?
  - Determine the number  $N'(5)$ .
  - Interpret the meaning of  $N'(5)$ .
- 72. Weekly attendance:** The semester after its student team won an intercollegiate Duplicate Bridge championship, the average weekly attendance at the University Union Building varied according to the formula  $B(t) = 100 - 50\left(1 - \frac{t}{16}\right)^{\frac{3}{2}}$ , where  $t$  is the number of weeks after the championship ( $0 \leq t \leq 16$ ) and  $B$  is the number of persons.
- What is  $B(0)$  and what does it represent?
  - Determine  $B'(t)$ .
  - What is  $B'(7)$ ? Interpret the meaning of this number.
- 73. Class registration:** The annual registration in university calculus classes varies according to the formula  $P(t) = 1 + \left(1 - \frac{t}{30}\right)^{2.5}$ , where  $t$  is the number of years since 2010 and  $P$  is in millions of students.
- Determine  $P(0)$  and explain its meaning.
  - Determine  $P'(t)$ .
  - Calculate  $P'(10)$  and explain its meaning.
- 74. Travel:** The number of passengers traveling from California to Central America and back on cruise ships is given by  $C(t) = (10t + 50)^{1.5}$ , where  $t$  is the number of years since 2005 and  $C$  is passenger count in thousands.
- When did the number of passengers hit 1,000,000 people ( $C = 1000$ )?
  - Compute  $C'(t)$ .
  - Calculate  $C'(12)$  and interpret its meaning.

$$\begin{aligned}
0 &= (16)^{\frac{1}{4}} \cdot \frac{3}{4} (81)^{-\frac{1}{4}} \frac{dy}{dt} + (81)^{\frac{3}{4}} \cdot \frac{1}{4} (16)^{-\frac{3}{4}} (4) \\
0 &= \cancel{2} \cdot \frac{\cancel{3}}{2\cancel{4}} \cdot \frac{1}{\cancel{3}} \cdot \frac{dy}{dt} + 27 \cdot \frac{1}{\cancel{4}} \cdot \frac{1}{8} \cdot \cancel{4} \\
0 &= \frac{1}{2} \cdot \frac{dy}{dt} + \frac{27}{8} \\
-\left(\frac{1}{2} \cdot \frac{dy}{dt}\right) &= \frac{27}{8} \\
\frac{dy}{dt} &= (-\cancel{2}) \frac{27}{\cancel{8}_4} \\
\frac{dy}{dt} &= -\frac{27}{4} = -6.75
\end{aligned}$$

Because the derivative is negative, the capital must **decrease** at a rate of  $\frac{27}{4} = 6.75$  units per month to keep the current level of production.

### 3.3 EXERCISES

#### PRACTICE

Use implicit differentiation to find  $\frac{dy}{dx}$  for each of the equations in Exercises 1–20.

1.  $2x^2 + y^2 = 4$

2.  $x^3 + y^3 = 5$

3.  $2x^3 + y^3 = 8$

4.  $x^2 - y^2 = 16$

5.  $\sqrt{x} + \sqrt{y} = 1$

6.  $x - \sqrt{y} = 2$

7.  $x^2y = 2$

8.  $xy^2 = -1$

9.  $x^2 + xy + y^2 = -1$

10.  $x^3 + 2xy - y^2 = 3$

11.  $4x^2 + 3xy + y^2 = 2x$

12.  $x^3 + y^3 = 3xy$

13.  $\frac{1}{x} + \frac{x}{y} = 2x$

14.  $x^2 + \frac{2x}{y} = \frac{1}{x^2}$

15.  $x^2 + \sqrt{xy} = 2y^2$

16.  $2y + \sqrt{xy} = 5x^2$

17.  $x^2y^2 + xy^3 = x^4$

18.  $x^3y + xy^3 = 3x^3$

19.  $x^2 + (y-2)^2 = 16$

20.  $x^2 + 4(y+3)^2 = 9$

In Exercises 21–30, use implicit differentiation to find  $\frac{dy}{dx}$  for the given equations; then find the slope of the tangent line at the given point.

- |  |   |
|--|---|
| 21. $4x^2 - 8y^3 = 24$ ; $(2, -1)$                 | 22. $3x^3 + 5y^2 + x = 1$ ; $(-1, 1)$           |
| 23. $x^2y - y^2 + 4x + 8 = 0$ ; $(1, 4)$           | 24. $5x^2 + xy^2 + 2x = 8$ ; $(-2, 2)$          |
| 25. $x^3 + 2xy - y^2 = 0$ ; $(3, -3)$              | 26. $4x^2 - 3xy + y^2 = 7$ ; $(2, 3)$           |
| 27. $\frac{1}{x} + \frac{x}{y^2} = 2x$ ; $(1, -1)$ | 28. $3x - \frac{2x}{y^2} + x^2 = 12$ ; $(3, 1)$ |
| 29. $2y + \sqrt{xy} = 5x^2$ ; $(2, 8)$             | 30. $x^2 - \sqrt{xy} = 2y^2 + 3x$ ; $(4, 1)$    |

In Exercises 31–40,  $x$  and  $y$  are functions of a third variable,  $t$ . Use implicit differentiation to find an expression for  $\frac{dy}{dt}$ .

- |                             |                         |                               |
|-----------------------------|-------------------------|-------------------------------|
| 31. $x^2 - 4y^2 = 16$       | 32. $3x^2 + y^4 = 4$    | 33. $x^3 + 5y^2 = 2x$         |
| 34. $6x^2 + 5x = 2y^2$      | 35. $\sqrt{xy} = 4$     | 36. $\sqrt{x} + \sqrt{y} = 3$ |
| 37. $x^2 + xy + y^2 = 3$    | 38. $x + 2xy - y^2 = 6$ | 39. $2xy + x^2 = y^3$         |
| 40. $x^2y^2 - y^3 + 4x = 0$ |                         |                               |

### APPLICATIONS

- 41. Retail sales:** The manager of an audio electronics store has determined that the number of stereo receivers and the number of speaker systems sold weekly are related by the equation  $0.9y^2 = 10x + xy$ , where  $x$  is the number of receivers and  $y$  is the number of speaker systems. Find  $\frac{dy}{dx}$  if  $x = 12$  and  $y = 20$ , and interpret your answer.
- 42. Retail sales:** The number of pairs of trousers  $x$  and the number of shirts  $y$  sold at a department store are related by the equation  $36x = 11y + 0.01x^2y$ . Find  $\frac{dy}{dx}$  when  $x = 10$  and  $y = 30$ , and interpret your answer.
- 43. Cobb-Douglas production:** The level of production of a company is given by  $P = 30x^{\frac{1}{3}}y^{\frac{2}{3}}$  units monthly, where  $x$  is the units of labor and  $y$  is the units of capital. The company is currently utilizing 64 units of labor and 27 units of capital. If labor is increased by 2 units per week, what will be the change in units of capital per week to maintain the current level of production?
- 44. Cobb-Douglas production:** The level of production of a company is given by  $P = 18x^{0.3}y^{0.7}$  units monthly, where  $x$  is the units of labor and  $y$  is the units of capital. The company is currently utilizing 35 units of labor and 24 units of capital. If capital is increased by 3 units per week, what will be the change in units of labor per week to maintain the current level of production?

45. **Rate of increase in cost:** The cost of producing  $x$  units of a product is given by the function  $C(x) = 0.02x^3 - x^2 + 8x + 200$ . The factory is currently producing 60 units per week but plans to increase production at a rate of 3 units per week. What will be the rate of increase in the total cost?

46. **Rate of decrease in cost:** The cost of producing  $x$  units of a commodity is given by the function  $C(x) = x^2 - 2x^{\frac{3}{2}} + 7x + 180$ . Currently, the production level is 36 units per day. The company plans to decrease production at a rate of 2 units per day. What will be the rate of decrease in the total cost?

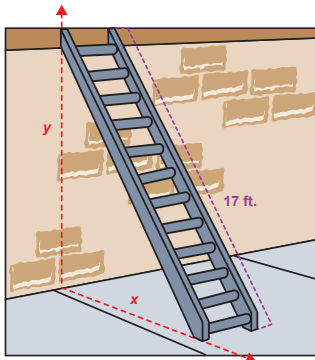

47. **Sliding ladder:** A 17 ft ladder is leaning against a wall. The bottom of the ladder is pulled away from the wall at a rate of 3 ft/sec. How fast is the top of the ladder moving down the wall when the top is 8 feet above the ground?

48. **Velocity:** Marijean is standing on a boat dock pulling in her boat by means of a rope attached to a boat at water level. Her hands are 6 feet above the water and she is pulling in the rope at a rate of 1.5 ft/sec. How fast is the boat approaching the dock if there are 10 feet of rope still out?

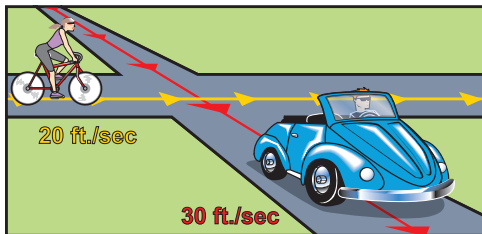
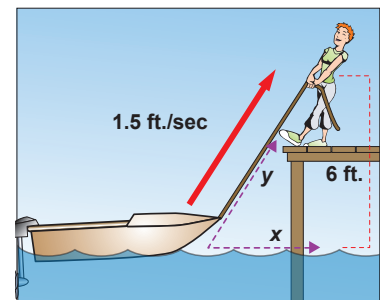

49. **Driving:** A car traveling south at 30 ft/sec crosses an intersection. When the car is 90 feet past the intersection, a bicyclist crosses the intersection traveling east at a rate of 20 ft/sec. How fast is the distance between the car and the bicycle increasing 5 seconds after the bicycle crosses the intersection?

50. **Distance to an airplane:** An airplane traveling at a height of 3000 feet crosses directly over an observer. The speed of the plane is 400 ft/sec. How fast is the distance between the observer and the plane changing after 10 seconds?

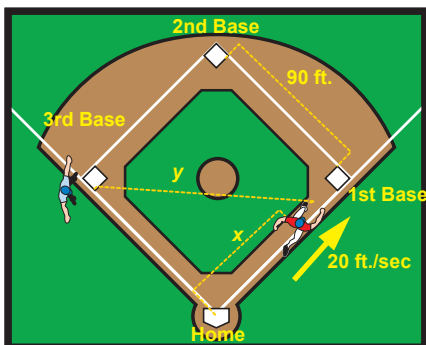
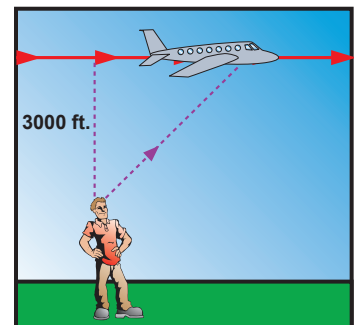

51. **Baseball:** A base runner heads towards first base with a speed of 20 ft/sec. A baseball diamond is a square, 90 feet on each side.

- How long will it take for the runner to reach first base?
- What is the runner's rate of change of distance from the umpire standing on third base (we will call this  $\frac{dy}{dt}$ )? (**Hint:** Use the diagram to get a relation between  $x$  and  $y$ .)
- What is the runner's speed when he arrives at first base?

- 52. Sailing:** A Coast Guard radar monitoring station on shore observed a sailboat on its radar grid. It was determined that the boat's east-west distance along the shoreline changed by the formula  $x = 12 + 0.1t$  and its seaward distance (north-south) changed by the formula  $y = 20 - 0.3t$ . Here,  $x$  and  $y$  are in miles and  $t$  is in minutes.
- What was the sailboat's position at  $t = 0$  minutes? Sketch this situation.
  - Determine  $\frac{dx}{dt}$  and  $\frac{dy}{dt}$ .
  - What is  $\frac{dy}{dx}$  at  $t = 10$ ? Interpret this number.
  - Where and when will the sailboat hit the shore (assuming it keeps its present heading)?
- 53. Bags of oranges:** Suppose the wholesale price in Miami of bags of oranges satisfies a demand equation of  $xp + 20p = 1040$ , where  $x$  is the number of bags supplied and  $p$  is the demand (unit price) in dollars.
- If 500 bags are available today, what is the unit price?
  - If the supply is increasing at the rate of 100 bags per day, at what rate is the price changing?
- 54. Dripping water:** The radius of a pan of water is 7 cm and water from a tap drips in at the rate of 10 cubic centimeters per minute.
- Determine  $\frac{dh}{dt}$ , where  $h$  is the height of water in the pan.
  - How long will it take to fill the pan to a height of 7 cm?
- 55. Demand:** The Arrow Marketing Group sells teddy bears with college logos to college and university gift shops. Their demand equation is  $px - 2800 = x$ , where  $x$  is the quantity of bears and  $p$  is the price in dollars that each sells for.
- How many bears can be sold (or "demanded") at \$4.50 apiece?
  - Determine a formula  $\frac{dx}{dp}$  and evaluate for  $p$  and  $x$  as in part a.
- 56. Electricity costs:** Electricity costs per semester at Mount State University are calculated by the formula  $C = 0.05x + 0.03y - 0.08xy$ , where  $x$  is a measure of student size and activity,  $y$  is dependent on the usage of various buildings and their efficiencies, and  $C$  is in millions of dollars.
- Determine  $C$  if  $x = 7$  and  $y = 9$ .
  - Determine a general formula for  $\frac{dy}{dx}$  and evaluate for  $x = 7$  and  $y = 9$ .

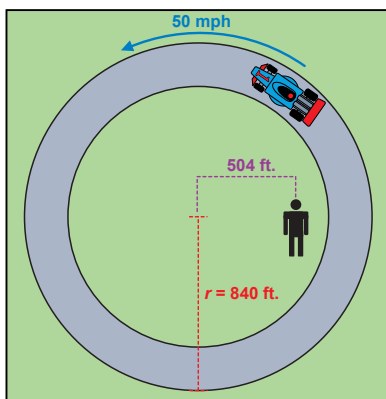

- 57. Race track:** A circular race track has a radius of 840 feet. At a certain point in time,  $t_0$ , an observer in a maintenance pit 504 feet from the center of the track clocks a car (when it is directly north of him) traveling counterclockwise along the track at a speed of 50 miles per hour from his right to left  $\left(\frac{dx}{dt}\right)$ . (Use 1 mile = 5280 feet.)
- Determine the location of the car on the track. Assume the center of the track is at the origin.
  - Determine a general equation for  $\frac{dy}{dx}$ .
  - What is  $\left.\frac{dy}{dx}\right|_{t=t_0}$ ? Interpret its meaning.
  - What is  $\frac{dy}{dt}$  at  $t = t_0$ ?

- 58. Chlorination costs:** Chlorination costs for the swimming pool at a spa are given by  $C = 0.27x + 2y - 0.001xy^2$ , where  $x$  is the number of weekly swimmers,  $y$  is the number of special functions, and  $C$  is in dollars.
- Determine  $C$  if  $x = 500$  and  $y = 4$ .
  - Determine a formula for  $\frac{dy}{dx}$  and evaluate at  $x = 500$  and  $y = 4$ .
- 59. Probability measurement:** The standard deviation,  $S$ , of a binomial random variable is given by  $S = \sqrt{np(1-p)}$ , where  $n$  is the number of trials or repetitions of an experiment and  $p$  is the probability of success on one outcome.  $S$  is a measure of how the data tends to vary from the center (or mean).
- For  $n = 768$  and  $p = 0.25$ , determine  $S$ .
  - Suppose we consider  $S$  as a fixed quantity. Determine  $\frac{dp}{dn}$  for  $n$  and  $p$  as in part a.

### Example 5: Graphing $f'(x)$

The graph for  $y = f(x)$  is given below. Identify the portions which show where  $f'(x)$  is negative, positive, or zero. Draw a possible graph of  $f'(x)$  by estimating the absolute values of the slopes on  $f(x)$ .

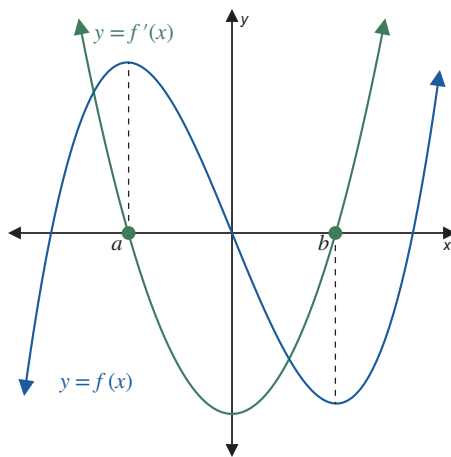
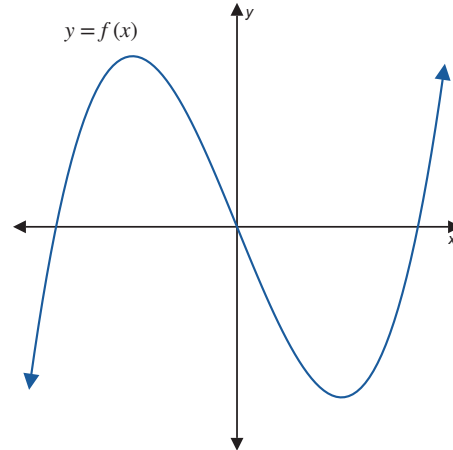

### Solution

Let  $x = a$  and  $x = b$  (say  $a < b$ ) denote the two  $x$ -values corresponding to the two local extremes. Then  $f'(a) = f'(b) = 0$ . In between  $a$  and  $b$ , the  $y$ -values decrease on the interval  $(a, b)$ ; therefore  $y'$  is negative. At  $x = b$ , the  $y$ -values start to increase (and  $y'$  becomes positive). Thus the graph of  $y'$  includes points  $(a, 0)$  and  $(b, 0)$  and lies below the  $x$ -axis (as  $y'$  is negative) from  $x = a$  to  $x = b$ . For  $x > b$  and  $x < a$ , the graph of  $y'$  lies above the  $x$ -axis. We draw a smooth curve from  $(a, 0)$  to  $(b, 0)$  and extend it in both directions above the  $x$ -axis. The low point for  $y'$  seems to occur near  $x = 0$  because the graph of  $y$  is steepest near  $(0, 0)$ .

## 3.4 EXERCISES

### 💡 PRACTICE

In Exercises 1–10, find the open intervals on which **a.**  $f$  is increasing, and **b.**  $f$  is decreasing.

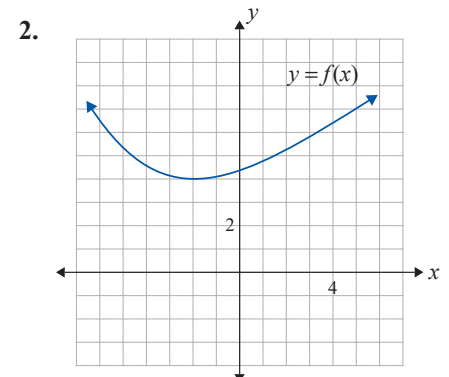
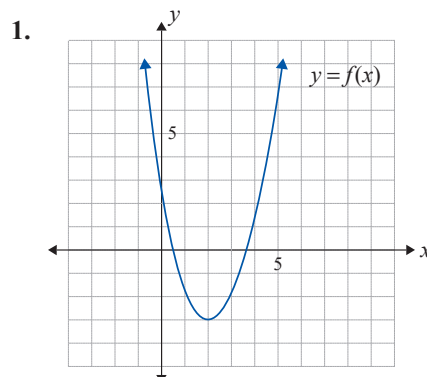

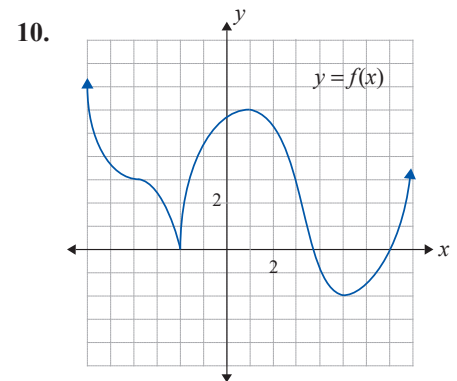
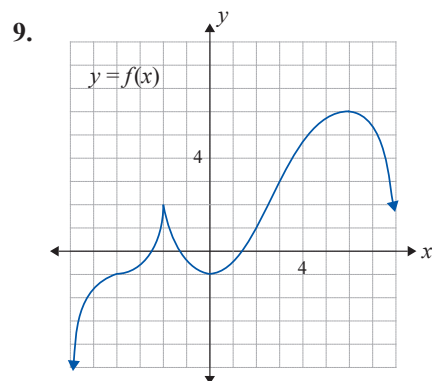
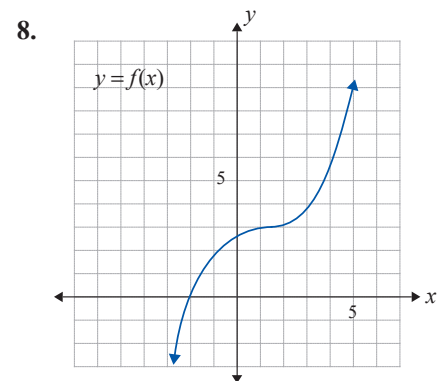
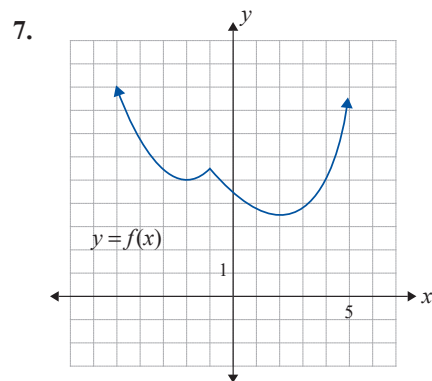
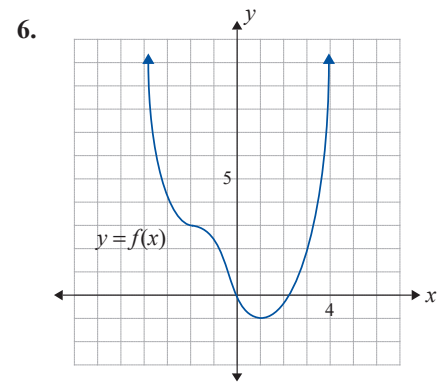
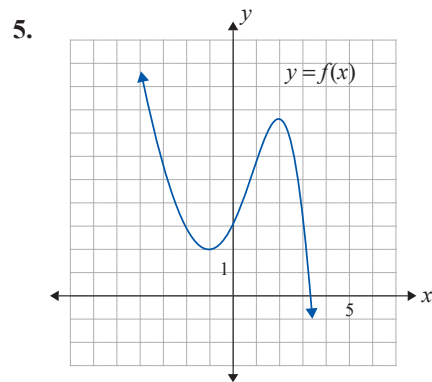
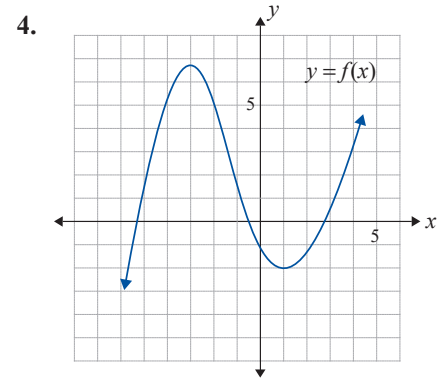
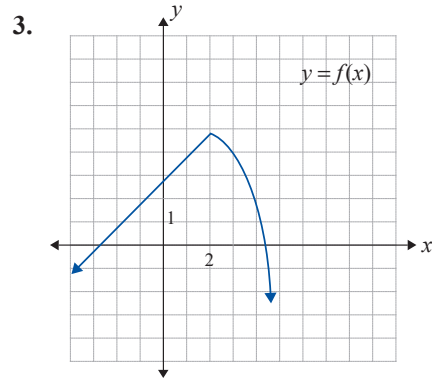

For each of the graphs of  $f(x)$  in Exercises 11–13, **a.** determine the open intervals on which the function is increasing and the open intervals on which it is decreasing, and **b.** sketch a possible graph of  $f'(x)$ .

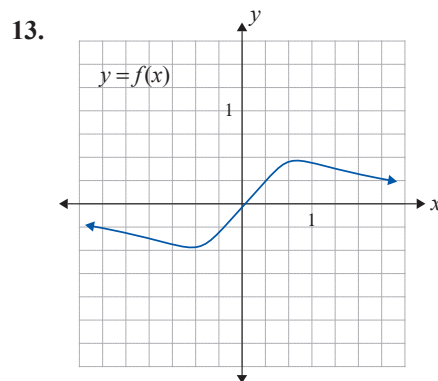
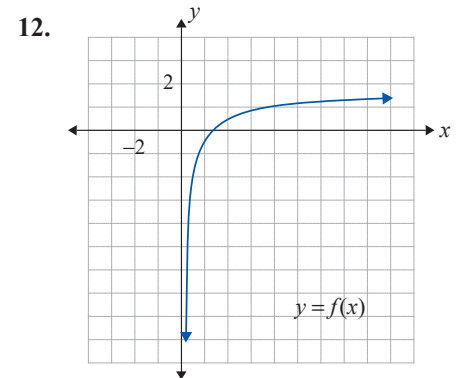
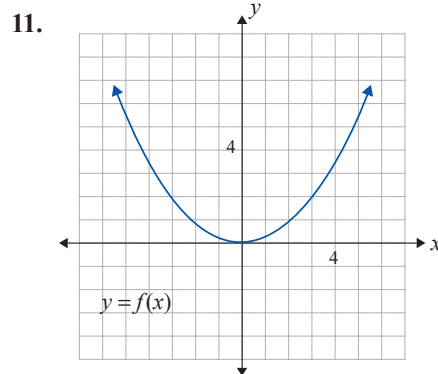

For each of the functions in Exercises 14–33, **a.** find all values of  $x$  that correspond to horizontal tangent lines, **b.** find the open intervals on which the function is increasing and the open intervals on which it is decreasing, and **c.** graph the function.

14.  $f(x) = x^2 - 8x + 3$

15.  $f(x) = 2x^2 + 12x - 1$

16.  $f(x) = 5 - 3x - x^2$

17.  $f(x) = 7x - 2x^2$

18.  $f(x) = 2 - 4x - 2x^2$

19.  $f(x) = 3x^2 - 4x + 2$

20.  $f(x) = (2x + 3)^2$

21.  $f(x) = (3x - 2)^2$

22.  $f(x) = 2x^3 - 5$

23.  $f(x) = 3x^3 + 4$

24.  $f(x) = x^3 - 3x^2 + 7$

25.  $f(x) = x^3 - 6x^2 - 4$

26.  $f(x) = x^3 - 3x^2 - 9x + 12$

27.  $f(x) = x^3 - x^2 - x$

28.  $f(x) = x^3 + \frac{1}{2}x^2 - 2x + 3$

29.  $f(x) = x^3 - x^2 - 5x + 2$

30.  $f(x) = \frac{1}{3}x^3 - x^2 - 8x + 10$

31.  $f(x) = \frac{1}{3}x^3 - 2x^2 + 3x - 6$

32.  $f(x) = \frac{1}{3}x^3 - \frac{3}{2}x^2 + 2x - 6$

33.  $f(x) = \frac{1}{3}x^3 + \frac{5}{2}x^2 + 4x + 11$

For each of the functions in Exercises 34–43, **a.** find all values of  $x$  that correspond to horizontal tangent lines, and **b.** find the open intervals on which the function is increasing and the open intervals on which it is decreasing.

34.  $f(x) = \frac{x-1}{x}$

35.  $f(x) = \frac{x}{x-2}$

36.  $f(x) = \frac{x^2-4}{x}$

37.  $f(x) = \frac{x^2-9}{x}$

38.  $f(x) = \frac{x^3+16}{x}$

39.  $f(x) = \frac{2x^3-27}{x^2}$

40.  $f(x) = \frac{x+2}{x-1}$

41.  $f(x) = \frac{x-5}{x+3}$

42.  $f(x) = 2x - \frac{125}{x^2}$

43.  $f(x) = x^2 + \frac{128}{x}$

### APPLICATIONS

44. **Revenue:** A store manager has determined that the revenue from the sale of  $x$  units of a product is given by  $R(x) = 32x - 0.4x^2$  dollars, where  $0 \leq x \leq 80$ . On what interval of sales is the revenue increasing, and on what interval of sales is it decreasing?
45. **Revenue:** A producer of computer software has determined that the revenue from the production and sale of  $x$  units is given by  $R(x) = 48x - 0.003x^2$  dollars, where  $0 \leq x \leq 10,000$ . For what interval of production is the revenue increasing, and for what interval is it decreasing?
46. **Profit:** The revenue from the sale of  $x$  coffee makers is given by  $R(x) = 40x - 0.4x^2$  dollars. The total cost is given by  $C(x) = 370 + 16x - 0.2x^2$  dollars, where  $0 \leq x \leq 100$ . Determine the interval(s) where the profit is increasing and where it is decreasing.
47. **Profit:** The revenue from the sale of  $x$  50-gallon aquariums is given by  $R(x) = 54x - 0.3x^2$  dollars. The total cost function is given by  $C(x) = 0.1x^2 + 4x + 200$  dollars, where  $0 \leq x \leq 100$ . Determine the interval of sales for which the profit is increasing and the interval for which it is decreasing.
48. **Population:** The population of the inner-city district of a city is given in thousands by  $P(t) = 24 - 0.3t + 0.01t^2$ , where  $t$  is the number of months after the implementation of an urban renewal project. How long will it be before the population starts to increase?
49. **Wildlife management:** In an attempt to naturally control the elk population in a national park, the U.S. Fish and Game Department has reintroduced the wolf into the area. It is estimated that the population of the elk herd will be  $P(t) = 600 + 12t - 4t^{\frac{3}{2}}$ , where  $t$  is the number of years after the reintroduction of the wolf. How long will it be before the elk population begins to decrease?
50. **Average cost:** The cost of producing  $x$  wireless speakers is given in dollars by  $C(x) = 320 + 30x + 0.2x^2$ , where  $x \geq 0$ . Determine the interval of production for which the average cost function is increasing.

- 51. Average cost:** The cost of producing  $x$  units of a product is given in dollars by  $C(x) = 250 + 45x - 0.2x^2$ , where  $x \geq 0$ . Show that the average cost function is always decreasing. (This case corresponds to situations in which increased production distributes the cost so that the cost per unit decreases.)

## 3.5 EXERCISES

 PRACTICE

For each of the functions in Exercises 1–20, **a.** find the critical values, and **b.** use the First Derivative Test to find any local extrema.

1.  $f(x) = 4x - x^2$

2.  $f(x) = 9x - x^2$

3.  $f(x) = x^2 + 6x - 2$

4.  $f(x) = x^2 - 10x + 12$

5.  $f(x) = \frac{1}{2}x^2 - 4x + 3$

6.  $f(x) = -\frac{1}{2}x^2 + 3x - 2$

7.  $f(x) = x^3 + x^2 - x + 3$

8.  $f(x) = x^3 + 2x^2 + x - 2$

9.  $f(x) = -x^3 - \frac{3}{2}x^2 + 18x + 6$

10.  $f(x) = 2x^3 + x^2 - 4x$

11.  $f(x) = x^3 - 3x + 6$

12.  $f(x) = x^3 + 3x^2 - 4$

13.  $f(x) = x + \frac{9}{x}$

14.  $f(x) = x - \frac{4}{x}$

15.  $f(x) = \frac{x^2 - 16}{x}$

16.  $f(x) = \frac{4x^2 - 9}{x}$

17.  $f(x) = 9x + x^{-1}$

18.  $f(x) = 25x + x^{-1}$

19.  $f(x) = 16x + x^{-2}$

20.  $f(x) = 54x - x^{-2}$

 APPLICATIONS

**21. Rate of dictation:** It has been determined that after  $t$  weeks of class, the average students in an intermediate shorthand class can take dictation at a rate of  $W(t) = 60 + \frac{70t^2}{t^2 + 15}$  words per minute. Show that the rate of dictation is an increasing function which approaches an upper bound.

**22. Court reporting:** A typical student in an intermediate court reporting class can reach a level of recording  $W(t) = 40 + \frac{35t^2}{t^2 + 20}$  words per minute after  $t$  hours of instruction and practice. Show that the number of words recorded per minute increases up to a certain level.

**23. Marathon running speed:** The speed at which a marathon runner travels varies over time. The function  $F(t) = 5 + \frac{5t^2}{t^2 + 200}$  describes the velocity of a particular runner at time  $t$  ( $F(t)$  is in miles/hour). Determine the intervals over which the function is increasing or decreasing. Is this particular runner an experienced runner? (Experienced runners run faster near the end of the race.)

**24. Heating:** A frozen pizza is placed in the oven at  $t = 0$ . The function  $F(t) = 30 + \frac{320t^2}{t^2 + 100}$  approximates the temperature of the pizza at time  $t$ . Show that the temperature approaches an upper bound. (The pizza will approach oven temperature as  $t \rightarrow \infty$ .)

- 25. Cooling:** A cup of hot coffee is placed in a room. The temperature in degrees Fahrenheit of the coffee is approximated by the function  $F(t) = 180 - \frac{100t^2}{t^2 + 40}$  where  $t$  is the number of minutes the coffee has been in the room. Show that the temperature function is a decreasing function, and find the temperature of the room. (The coffee approaches room temperature over time.)
- 26. Velocity and acceleration:** The velocity of a car varies according to the function  $F(t) = \frac{t^3}{1875} - \frac{119t^2}{1500} + \frac{53t}{15} + 5$ , where  $t$  is time ( $0 < t < 100$ ). Determine any local maximum and minimum velocities, and the times at which they occur. (Be sure to specify whether each is a maximum or minimum.)
- 27. Skydiving:** The velocity of a skydiver after parachute deployment is given by the formula  $F(t) = 180 - \frac{165t^2}{t^2 + 10}$ , where  $t$  is the time after deployment. Show that the function is decreasing, and determine the terminal velocity for the diver-parachute system. (The velocity approaches terminal velocity as  $t$  goes to infinity.)
- 28. Pressure:** The pressure in a pressure cooker is given by the function  $F(T) = 1 + \frac{3T^2}{T^2 + 180}$ , where  $T$  is the temperature inside the kettle. Show that the function is increasing, and determine the upper bound for pressure.
- 29. Space probe closing speed:** In order to minimize travel time, a fictional probe on its way to a distant star accelerates for part of the voyage, and then decelerates to enter orbit safely. The closing speed of the probe with the star is given by the function  $F(t) = \frac{t^2}{25} - 4t + 0.5$ , where  $t$  is the number of years after launch and  $F(t)$  is measured in percentage of light speed. At what time does the probe begin decelerating? What is the probe's maximum closing speed? (**Hint:** Closing speed is negative.)
- 30. Computation speed:** An experimental supercomputer is undergoing testing to determine whether it will meet the necessary specifications. The number of computations it can perform per second is found to be modeled by the function  $F(t) = \frac{89t^3}{441,000} - \frac{757t^2}{22,050} + \frac{2227t}{1470}$ , where  $0 < t < 100$  is the number of minutes after startup and  $F(t)$  is in quadrillions of computations/sec. Find all relative maximums and minimums for the function over the interval. Round to the nearest tenth. If the number of computations is zero at any time after startup, the computer crashes. Does the computer crash during testing?
- 31. Fuel economy:** The fuel consumption of an automobile is not constant. Fuel economy depends largely on the speed of the vehicle. The function  $F(v) = -\frac{8v^3}{19,125} + \frac{28v^2}{85} - \frac{288v}{85} + 80$  ( $F(v)$  is in miles per gallon) describes the fuel consumption of a new hybrid vehicle, where  $0 < v < 85$  is the velocity of the vehicle. On what intervals is the consumption increasing? Which velocities yield maximum efficiencies? (Remember, high efficiency means low consumption. Round to the nearest tenth.)

### Example 5: Maximizing Profits

A company finds that its profit in dollars for producing  $x$  units of a product in one week is given by  $P(x) = -2x^2 + 1600x$ . If the company is set up so that no more than 500 units can be manufactured in any one week, how many units should the company produce to maximize profit?

### Solution

The production restrictions indicate that  $x$  is in the closed interval  $[0, 500]$ . Find the critical values by setting  $P'(x) = 0$  and solving for  $x$  (Step 1).

$$P'(x) = -4x + 1600$$

Note that  $P'$  is defined for all  $x$  in  $[0, 500]$ .

$$0 = -4x + 1600$$

$$4x = 1600$$

$$x = 400$$

Now evaluate  $P(x)$  for  $x = 0$ ,  $x = 400$ , and  $x = 500$  (Step 2).

$$x = 0$$

$$P(0) = -2(0)^2 + 1600 \cdot 0 = 0$$

$$x = 400$$

$$P(400) = -2(400)^2 + 1600 \cdot 400 = 320,000 \quad \text{Absolute max}$$

$$x = 500$$

$$P(500) = -2(500)^2 + 1600 \cdot 500 = 300,000$$

The profit is maximized at \$320,000 when 400 units are produced (Step 3).

## 3.6 EXERCISES

### 💡 PRACTICE

In Exercises 1–8, find the absolute extrema for each graph of  $f(x)$  on the given interval.

1.  $[3, 5]$

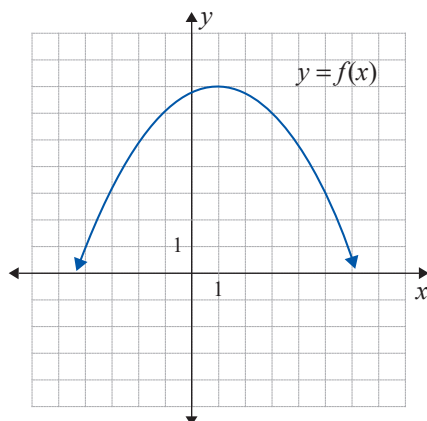

2.  $[-1, 4]$

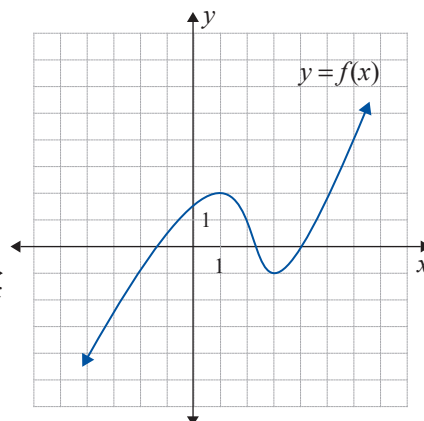

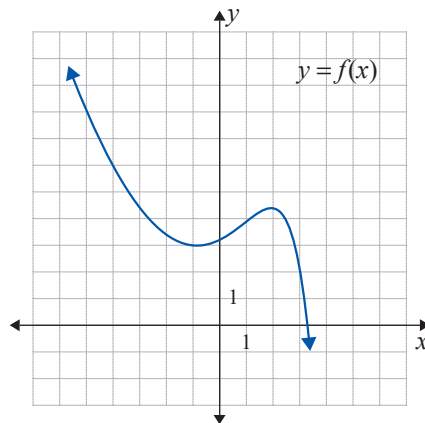
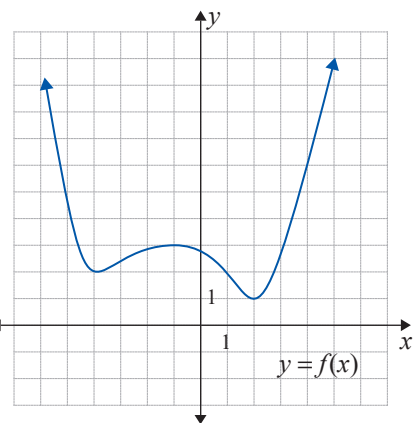
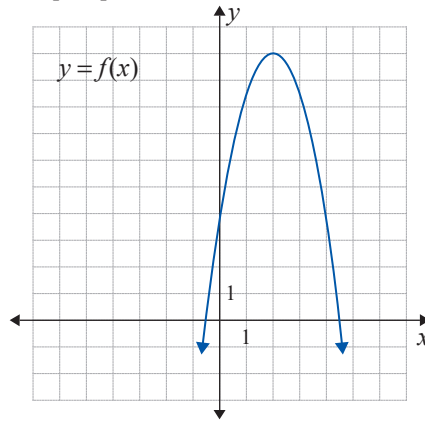
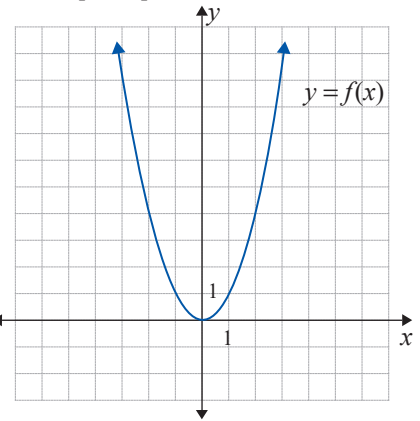
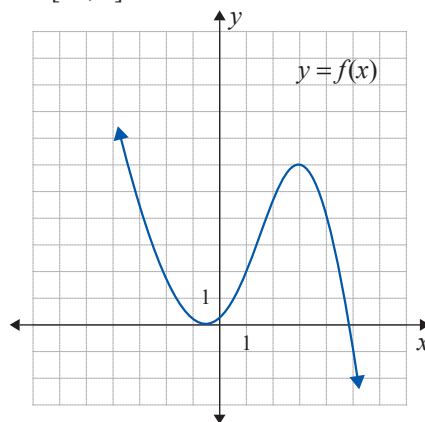
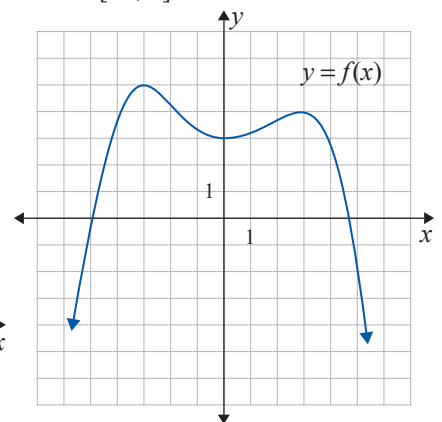
3.  $[-5, 3]$ 4.  $[-4, 4]$ 5.  $[1, 4]$ 6.  $[-2, 2]$ 7.  $[-3, 5]$ 8.  $[-4, 5]$ 

In Exercises 9–38, find the absolute extrema for each function on the given interval.

9.  $f(x) = x^2 - 8x$ ;  $[0, 5]$

10.  $f(x) = 3x^2 - 12x$ ;  $[0, 4]$

11.  $f(x) = 6 + 10x - x^2$ ;  $[3, 6]$

12.  $f(x) = 11 - 4x - x^2$ ;  $[-3, 0]$

13.  $f(x) = 14 - 3x$ ;  $[0, 4]$

14.  $f(x) = 7 + \frac{1}{2}x$ ;  $[-2, 4]$

15.  $f(x) = 8 - x^3$ ;  $[-1, 3]$

16.  $f(x) = x^3 + 4$ ;  $[-2, 2]$

17.  $f(x) = x^3 - 12x$ ;  $[-3, 4]$
18.  $f(x) = x^3 - 3x$ ;  $[-2, 3]$
19.  $f(x) = 2x^3 - x^2$ ;  $[0, 2]$
20.  $f(x) = x^3 + 2x^2$ ;  $[0, 3]$
21.  $f(x) = 9x - 3x^2 - x^3$ ;  $[-4, 2]$
22.  $f(x) = x^3 - 3x^2 - 24x$ ;  $[-3, 3]$
23.  $f(x) = 2x^3 - 3x^2 - 12x - 10$ ;  $[0, 4]$
24.  $f(x) = x^3 + 3x^2 - 24x$ ;  $[0, 3]$
25.  $f(x) = x^{\frac{2}{3}} - 4$ ;  $[-1, 8]$
26.  $f(x) = 3x^{\frac{2}{3}} + 2$ ;  $[-1, 4]$
27.  $f(x) = 3x^{\frac{1}{3}} - 4x$ ;  $[0, 1]$
28.  $f(x) = 3x^{\frac{2}{3}} + x$ ;  $[-9, 1]$
29.  $f(x) = \sqrt{x^2 + 4}$ ;  $[-1, 2]$
30.  $f(x) = \sqrt{9 - x^2}$ ;  $[-1, 2]$
31.  $f(x) = \sqrt[3]{x^2 - 1}$ ;  $[-2, 2]$
32.  $f(x) = (x^2 - 1)^{\frac{2}{3}}$ ;  $[-2, 2]$
33.  $f(x) = x + \frac{4}{x}$ ;  $\left[\frac{1}{2}, 3\right]$
34.  $f(x) = 2x + \frac{18}{x}$ ;  $[1, 4]$
35.  $f(x) = 4x + \frac{9}{x}$ ;  $[1, 3]$
36.  $f(x) = 9x + \frac{16}{x}$ ;  $[1, 2]$
37.  $f(x) = x^2 + \frac{16}{x}$ ;  $\left[\frac{1}{2}, 4\right]$
38.  $f(x) = x^2 + \frac{2}{x}$ ;  $[1, 4]$

### APPLICATIONS

39. **Revenue:** The weekly revenue from the sale of  $x$  units of a product is given by  $R(x) = 24x - 0.5x^2$  dollars. If the company is set up so that it can produce no more than 40 units per week, how many units should the company produce to maximize revenue?
40. **Revenue:** The revenue from the sale of  $x$  units of a product is given by  $R(x) = 12x - 0.04x^2$  thousand dollars, where  $0 \leq x \leq 250$ . How many units should be sold to maximize the revenue?
41. **Profit:** A manufacturer of telescopes has determined that the revenue from the production and sale of  $x$  telescopes is  $R(x) = 140x - 0.5x^2$  dollars. The cost function is given by  $C(x) = x^2 + 20x + 1050$  dollars. Find the level of production and sales that will maximize the profit if  $0 \leq x \leq 70$ .
42. **Profit:** A marketing analyst for a company that produces skateboards has determined that if the company sells  $x$  units of the deluxe model, the revenue function is  $R(x) = 79.9x - 0.03x^2$  dollars and the cost function is  $C(x) = 0.08x^2 + 5.1x + 5800$  dollars. Find the sales level that will yield maximum profit if  $0 \leq x \leq 380$ .
43. **Average cost:** The cost of producing  $x$  compact refrigerators is given by  $C(x) = 2880 + 35x + 0.2x^2$  dollars. Find the value of  $x$  that minimizes the average cost function if  $0 \leq x \leq 150$ .
44. **Average cost:** The cost of producing  $x$  electronic games is given by  $C(x) = 1080 + 42x + 0.3x^2$  dollars. Find the value of  $x$  that minimizes the average cost function if  $0 \leq x \leq 90$ .

- 45. Air quality:** The Air Quality Management District monitors the level of pollution in the air. On a good day, the level is approximately  $P(t) = 35 + \frac{126t}{0.5t^2 + 18}$  PSI (Pollution Standard Index), where  $t$  is the number of hours after 7:00 a.m. and  $0 \leq t \leq 11$ . At what time will the pollution level be a maximum?
- 46. Air quality:** On a moderately smoggy day, the level of nitrogen dioxide in the air is approximately  $N(t) = 0.126 + \frac{0.36t}{2t^2 + 40.5}$  ppm (parts per million), where  $t$  is the number of hours after 8:00 a.m. and  $0 \leq t \leq 10$ . At what time will the level of nitrogen dioxide reach its maximum?
- 47. Bacteria:** It is estimated that  $t$  hours after a particular bacterium is introduced into a culture, the population of bacteria in the culture will be  $P(t) = \frac{4800}{\sqrt{12 - 0.5t}}$ , where  $0 \leq t \leq 6$ . What will be the absolute maximum population? At what time  $t$  will this occur?
- 48. Population:** It is estimated that  $t$  years from now the population of a small community will be  $P(t) = \frac{5000}{\sqrt{25 + 0.4t}}$  people, where  $0 \leq t \leq 10$ . What will be the maximum population?
- 49. Altitude:** The altitude of an airplane following a certain flight path is given by the function  $F(t) = \frac{13t}{20} - \frac{3t^2}{200}$ , where  $t$  is in minutes, and  $F(t)$  is in thousands of feet. Find the absolute maximum of the function over the interval  $[0, 43]$ .
- 50. Velocity of a car:** The velocity of a car in miles per hour varies according to the function  $F(x) = \frac{x^2}{100} - \frac{19x}{25} + \frac{5349}{100}$ , where  $x$  denotes time in seconds. Find the absolute maximum and minimum velocities over the interval  $[0, 100]$ . Find the car's velocity at each endpoint.
- 51. Tire distortion:** When a car accelerates, its tires are distorted by the force exerted on them by the motor. For a certain model car, the distortion after the driver floors the accelerator is modeled by the function  $F(t) = 0.00026t^3 - 0.0533t^2 + 2.74014t$ , where  $0 < t < 100$  is the number of milliseconds after acceleration begins, and  $F(t)$  is a percentage of the tire's maximum flexibility (at  $F(t) = 100$ , the tire tears into pieces). Find the time when the maximum distortion occurs, and find the percentage that the tires are distorted. Do the tires survive the acceleration?
- 52. Pollution:** The amount of pollution (measured in parts per million) in a small river is given by the function  $F(t) = \frac{450t^3}{169} - \frac{18,225t^2}{169} + \frac{23,625t}{23} + \frac{260,675}{169}$ , where  $t$  is the number of years after 1980. Sometime after 1980, an environmental protection law was enacted to reduce the amount of pollution in the river, and in the same year the pollution levels began to decrease. Find the maximum pollution for  $0 \leq t \leq 20$ , and determine the year the law was enacted. (The largest integer less than the  $t$ -value specifies the year of enactment.)

**53. Profit:** The weekly revenue from the sale of a particular style of shirt is  $R(x) = 43x - 0.02x^2$  dollars. The total cost for the shirts is  $C(x) = 0.04x^2 + 13x + 1200$  dollars. Find the sales level that will yield maximum profit.

**54. Bacteria:** A bacteriologist doing research on antibiotics has discovered that a certain type of disease-causing bacteria can be effectively treated using a cocktail of two different antibiotics administered at specific intervals. The population changes in response to the antibiotics according to the function  $F(t) = -0.0224t^3 + 4.5676t^2 - 252.4610t + 5000$ , where  $t$  is in the interval  $[0, 200]$ . The maximum values of the function correspond to the times when the antibiotics were administered. At what times,  $t$ , are the antibiotics administered and what is the population of bacteria at those times?

**55. Gravitational pull:** A rocket traveling to the moon is affected by the gravity of Earth and of the moon. The total gravitational force exerted on the rocket is approximated by the function  $F(h) = \frac{43,750h^2}{3} - \frac{70,000h}{3} + 10,000$ , where  $0 < h < 1$  is the height of the object, given in percentage of the distance between Earth and the moon, and  $F(h)$  is measured in newtons. Find the height at which the minimum occurs and the gravitational force at that altitude. Additionally, there is an onboard experiment which can only be performed if the gravitational force falls below 1000 newtons. Can this experiment be performed?

**56. Population:** It is estimated that  $t$  years from now the population of a town will be  $P(t) = 4500 + \frac{400t}{t^2 + 4}$ , where  $0 \leq t \leq 5$ . Find the maximum population.

**57. Acceleration:** Due to many variable factors in car engines, acceleration is never constant. The acceleration of a particular car in a particular test is approximated by the function  $F(t) = -\frac{260t^3}{137} + \frac{2418t^2}{137} - \frac{7371t}{137} + 75$ , where  $0 \leq t \leq 5$  is the number of seconds after acceleration begins. What is the maximum acceleration of the car during this test? When does it occur? What is the minimum acceleration, and when does it occur?

**58. Power consumption:** A certain piece of equipment in a chemistry lab draws power according to the function

$$G(m) = (-6.087 \times 10^{-6})m^3 + (8.641 \times 10^{-3})m^2 - 1.751m + 1000,$$

where  $0 < m < 1000$  is the mass of the sample to be analyzed in grams and  $G$  is power consumption in watts. Find the sample mass which causes the equipment to draw the most power. How much power does the equipment draw for a sample of this mass?

- 59. Chemistry:** A certain chemical procedure requires the addition of reactants and catalysts at precise times to maintain reaction rates. The rate of reaction is given by the function

$$H(t) = (9.423 \times 10^{-7})t^3 - (1.230 \times 10^{-4})t^2 + (4.384 \times 10^{-3})t + 0.001,$$

where  $0 < t < 100$  is the number of seconds after beginning the reaction, and  $H(t)$  is measured in number of moles formed per second. Find the time at which a relative maximum reaction rate is reached and the number of moles per second being formed at that time. At what time was the second reactant/catalyst mixture added? (The reactant/catalyst mixture is added at a relative minimum.) Round to two decimal places.

- 60. Phone traffic:** Phone traffic varies greatly over the course of a day. A phone provider estimates that the number of international calls active per minute on a certain holiday is given by the function  $P(t) = -0.001t^3 + t^2 + 50t + 150,000$ , where  $0 < t < 1000$  is the number of minutes after 6.00 a.m. and  $P(t)$  is the number of active international calls. For what  $t$  does maximum phone traffic occur? How many calls are active at this time?

- 61. Stored energy:** While a rubber ball is moving, it has kinetic energy. When the ball impacts a hard surface, the kinetic energy is converted to potential energy, and then back to kinetic energy. This happens quite rapidly. The amount of potential energy after impact is approximated by the function  $E(t) = -\frac{3t^2}{80} + \frac{3t}{2}$ , where  $t$  is the number of nanoseconds after impact and  $t$  is in  $[0, 40]$ . When does the ball have maximum potential energy? How much potential energy does it have at its maximum?

- 62. Photosynthesis:** Plants absorb different amounts of light, depending on the wavelength of the light. A study of Rhododendron bushes show that they absorb light according to the formula  $L(w) = \frac{-2.22w^3}{10^{10}} + \frac{4.44w^2}{10^6} - \frac{2w}{10^3} + 0.444$ , where  $100 \leq w \leq 650$  is the wavelength of light in nanometers, and  $L(w)$  is the proportion of the light shone on the bush. What wavelength does Rhododendron absorb the best? What proportion of light of this wavelength does Rhododendron absorb?

- 63. Package delivery:** A study says that the package flow in the Southeast USA during the month of August follows the function  $D(t) = \frac{7t^3}{9300} - \frac{7t^2}{248} + \frac{7t}{31} + 1$ , where  $1 \leq t \leq 31$  is the day of the month, and  $D(t)$  is given in millions of packages. On which day are the most packages delivered? How many packages are delivered on this day?

We set  $f''(x) = 0$  and obtain

$$\begin{aligned} 16x - 12x^2 &= 0, \text{ so} \\ 4x(4 - 3x) &= 0. \end{aligned}$$

Thus  $x = 0$  and  $x = \frac{4}{3}$  will make  $f''(x)$  equal to zero. Both values give inflection points for  $f(x)$ .

We can use  $f'(x) = 0$  to locate the maximum and minimum points for  $f(x)$ .

$$\begin{aligned} f'(x) &= 0 \\ 8x^2 - 4x^3 &= 0 \\ 4x^2(2 - x) &= 0 \\ x &= 0, 2 \end{aligned}$$

In Figure 8, we observe  $x = 0$  corresponds to an inflection point (neither a maximum nor a minimum) and  $x = 2$  corresponds to the maximum point  $\left(2, \frac{31}{3}\right)$ .

In this problem, the algebraic solutions of  $f'(x) = 0$  and  $f''(x) = 0$  are of a familiar type. When these equations are too difficult for an algebraic solution, a graphing calculator is invaluable.

## 4.1 EXERCISES

### 💡 PRACTICE

- At each point marked on the graph of  $f$ , determine if  $f'$  is positive, negative, or zero. Determine if  $f''$  is positive, negative or zero.

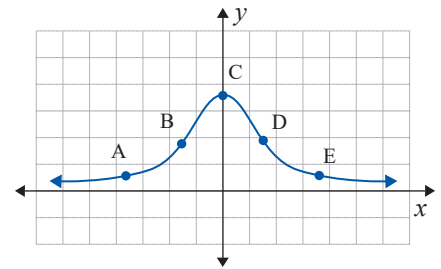

Draw a graph that satisfies the given conditions in Exercises 2–5.

- $f(5) = 9$ ,  $f'(5) = 2$ ,  $f''(5) = -2$
- $f(-5) = -9$ ,  $f'(-5) = 2$ ,  $f''(-5) = 2$
- $f(5) = -9$ ,  $f'(5) = 0$ ,  $f''(5) = 3$
- $f(0) = 12$ ,  $f'(0) = 0$ ,  $f''(0) = -3$

For Exercises 6–13, find  $f''(x)$ . Then evaluate  $f''(0)$ ,  $f''(1)$ , and  $f''(4)$ , if they exist.

- $f(x) = x^3 + x^2 + 3$
- $f(x) = x^3 - x^2 + 7$
- $f(x) = x^2 - 5\sqrt{x} + 1$
- $f(x) = x^2 + 2\sqrt{x} - 3$

10.  $f(x) = \sqrt{x-4}$

11.  $f(x) = \sqrt{2x+1}$

12.  $f(x) = \frac{x}{x+5}$

13.  $f(x) = \frac{x-2}{x+4}$

In Exercises 14–17, sketch a possible graph for  $f'(x)$  on the same coordinate axes as  $f(x)$ . Then locate all inflection points on the graph of  $f(x)$ .

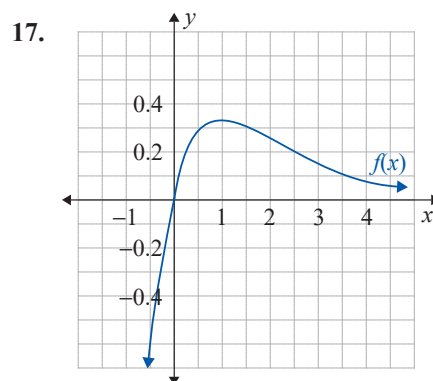
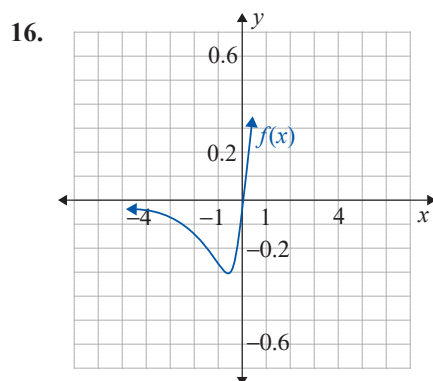
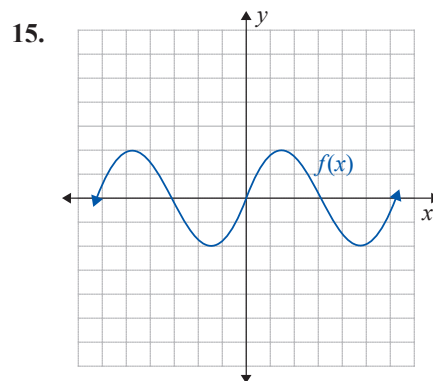
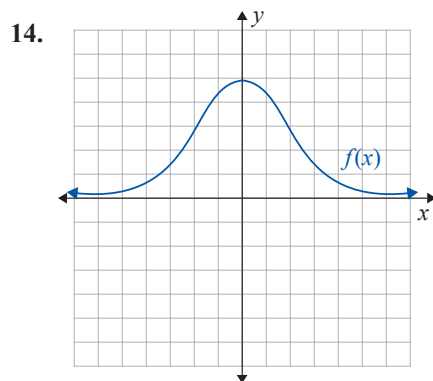

For each of the graphs in Exercises 18–21, list the interval(s) **a.** on which  $f$  is concave upward and **b.** on which  $f$  is concave downward; then **c.** locate all points of inflection.

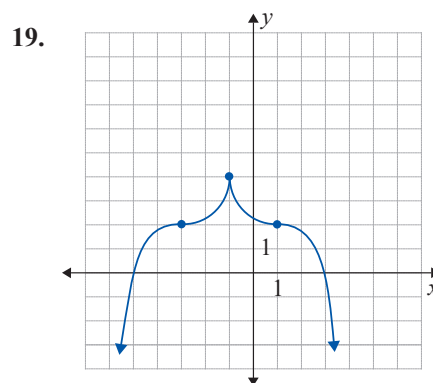
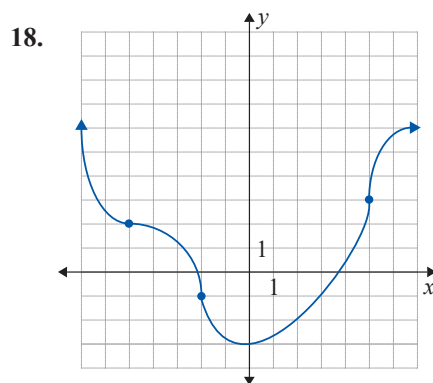

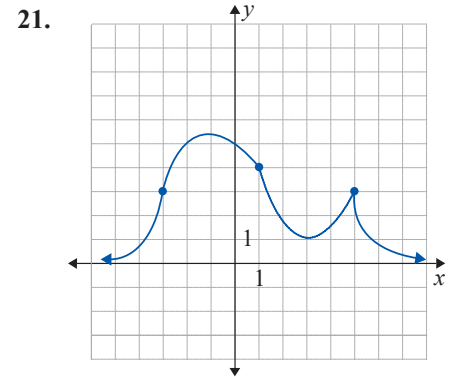
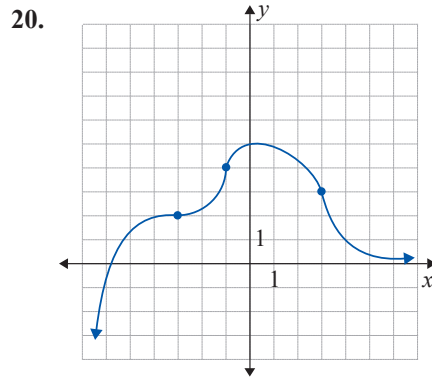

In Exercises 22–33, determine the intervals on which each function is **a.** concave upward and **b.** concave downward; then **c.** locate all points of inflection. Use the information gathered to sketch the function. Confirm the details with a graphing calculator.

22.  $f(x) = 2x^2 + 5x - 9$

23.  $f(x) = 5x^2 + 8x - 1$

24.  $f(x) = x^3 - 3x^2 + 7$

25.  $f(x) = x^3 + 6x^2 - 10$

26.  $f(x) = x^3 + 11x - 4$

27.  $f(x) = 5x^3 + 7x + 2$

28.  $f(x) = \frac{1}{3}x^3 - 2x^2 + x - 3$

29.  $f(x) = \frac{1}{3}x^3 + 3x^2 + 2x - 5$

30.  $f(x) = \sqrt[3]{2x+3}$

31.  $f(x) = \sqrt[3]{5x-3}$

32.  $f(x) = \frac{x}{x^2-4}$

33.  $f(x) = \frac{4x}{x^2-5}$

### WRITING & THINKING

In Exercises 34–37, give an example of a polynomial function that satisfies the conditions.

34.  $F(5) = 15$ ;  $F'(x)$  is nonzero, but  $F''(x) = 0$  for all  $x$ .

35.  $G(0) = 0$ ,  $G'(0) = 0$ , and  $G''(0) = 0$ ;  $G(x)$  is concave upward everywhere and has no inflection points.

36.  $H(4) = 0$ ;  $H'(x)$  is positive for  $x > 4$  and negative for  $x < 4$ .  $H(x)$  has no inflection points.

37.  $J(4) = 0$ ;  $J'(4)$  is zero but  $J'(x)$  is positive if  $x \neq 4$ ;  $J''(4) = 0$ .

### APPLICATIONS

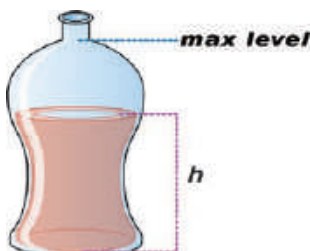

38. **Filtrate:** In a chemistry lab a filtrate drips slowly but continuously at a constant rate into a glass container shaped like the one shown. The container eventually fills to the base of the neck. Let  $t$  denote the passage of time and  $h$  be the height of the liquid.

**a.** Describe at what points on the bottle  $\frac{dh}{dt}$  will be a maximum and a minimum.

**b.** Sketch a graph of  $\frac{dh}{dt}$ . Are there any inflection points on a graph of  $y = h(t)$ ?

**c.** Add a sketch of  $y = h(t)$  on the same coordinate axes as in part **b.**

Testing shows that

$$S''(x) > 0 \quad \text{for } 0 < x < 50$$

and

$$S''(x) < 0 \quad \text{for } 50 < x < 80.$$

Concavity changes from upward on the left side of  $S(50)$  to downward on the other, signifying it is a point of diminishing returns.

Thus the point of diminishing returns is at  $(50, S(50)) = (50, 5100)$ . At the point of diminishing returns, \$50,000 are spent on advertising, and sales in tires are \$5,100,000.

## 4.2 EXERCISES

### PRACTICE

Find both the first and second derivatives for each of the functions in Exercises 1–12. Locate any relative maximum or minimum points and any points of inflection. Determine the intervals on which the function is concave upward or concave downward.

1.  $f(x) = 7x^2 - 28x + 8$

2.  $f(x) = 5x^2 - 9x + 2$

3.  $f(x) = 2x^3 + 5x - 1$

4.  $f(x) = 3x^3 + 6x - 8$

5.  $f(x) = x^3 + 2\sqrt{x} + 5$

6.  $f(x) = x^4 - 3\sqrt{x} + 2$

7.  $f(x) = (x^2 + 7)^2$

8.  $f(x) = (2x^2 - 5)^2$

9.  $f(x) = \sqrt{x^2 + 3}$

10.  $f(x) = \sqrt[3]{x^2 + 9}$

11.  $f(x) = \frac{3x}{x^2 + 1}$

12.  $f(x) = \frac{2x + 1}{x^2 - 4}$

In Exercises 13–16, find all inflection points. Apply the Second Derivative Test at possible maximum/minimum points. Make a sketch of the graph and confirm your results with a graphing calculator.

13.  $f(x) = (x + 5)\sqrt[3]{x}$

14.  $f(x) = (x^2 + 1)\sqrt[3]{x}$

15.  $f(x) = 2x\sqrt[3]{x+1}$

16.  $f(x) = (x + 10)\sqrt[3]{x^2 + 10}$

In Exercises 17–30, use the Second Derivative Test to find all local extrema, if the test applies. Otherwise, use the First Derivative Test.

17.  $f(x) = x^2 - 3x + 5$

18.  $f(x) = 8 + 7x - 2x^2$

19.  $f(x) = x^3 - 3x^2 + 8$

20.  $f(x) = x^3 + 6x^2 - 10$

21.  $f(x) = x^3 - 12x + 3$

22.  $f(x) = x^3 - 3x + 4$

23.  $f(x) = \frac{2}{3}x^3 - x^2 - 4x - 2$

24.  $f(x) = \frac{1}{3}x^3 + x^2 - 3x - 1$

25.  $f(x) = x^4 - 8x^2 + 7$

26.  $f(x) = x^4 - 2x^2 + 3$

27.  $f(x) = x^4 + 2x^3 - 4$

28.  $f(x) = x^4 - 6x^3 + 8$

29.  $f(x) = 2x + \frac{8}{x}$

30.  $f(x) = \frac{x^2 + 9}{x}$

 **APPLICATIONS**

**31. Point of diminishing returns:** Find the point of diminishing returns for the sales function  $S(x) = 112 + 1.8x^2 - 0.1x^3$ , where  $x$  represents thousands of dollars spent on advertising,  $0 \leq x \leq 10$ , and  $S$  is sales in thousands of dollars.

**32. Point of diminishing returns:** The sales function for a product is given by  $S(x) = 204 + 6.3x^2 - 0.25x^3$ , where  $x$  represents thousands of dollars spent on advertising,  $0 \leq x \leq 12$ , and  $S$  is sales in thousands of dollars. Find the point of diminishing returns.

**33. Marginal cost:** The cost function for a particular product is given by  $C(x) = 0.1x^3 - 2.4x^2 + 24x + 190$  dollars, where  $0 \leq x \leq 12$ . Find the minimum marginal cost.

**34. Marginal cost:** Find the minimum marginal cost of a product if the cost function is given by  $C(x) = 0.0001x^3 - 0.036x^2 + 16.8x + 1900$  dollars, where  $0 \leq x \leq 150$ .

**35. Law enforcement:** Due to the rapid increase in major crimes, the mayor of a large city plans to organize a major crime task force. It is estimated that for every 1000 persons in the city, the numbers of major crimes will be  $N(t) = 56 + 3t^2 - 0.8t^{\frac{5}{2}}$ , where  $t$  is the number of months after the task force is organized and  $0 \leq t \leq 12$ .

- Find the maximum  $N(t)$ .
- Find the maximum rate of increase in  $N(t)$ .

**36. Meteorology:** Meteorology records for a certain city suggest that for the month of June, the temperature between midnight and 6:00 p.m. can be approximated by  $T(t) = -0.04t^3 + 1.14t^2 - 7.2t + 66$  degrees, where  $t$  is the number of hours after midnight and  $0 \leq t \leq 18$ .

- Find the maximum and minimum temperatures.
- Find the maximum rate of increase in the temperature.

 **WRITING & THINKING**

**37.** Given  $f(x) = px^3 + bx + 10$ , answer the following questions.

- Suppose  $p$  and  $b$  are positive numbers. What can be said about maximum/minimum points and points of inflection?
- Suppose  $p$  and  $b$  have opposite signs (one is positive and the other negative). What can be said about maximum/minimum points and points of inflection?
- If the constant term 10 is changed to some other value, do your responses to parts **a.** and **b.** change?
- Put your answers to parts **a.**, **b.**, and **c.** together in a “Lab Report” that discusses the coefficients in the given polynomial  $y = px^3 + bx + c$ .

## Example 5: Graphing the Derivative

Consider the given graph of a function.

- Identify the local extrema and locate the point(s) of inflection.
- Determine the intervals on which  $f(x)$  is increasing and on which  $f(x)$  is decreasing, and identify the intervals on which  $f(x)$  is concave upward and concave downward.
- Sketch on the same coordinate plane a possible graph of  $f'(x)$ .

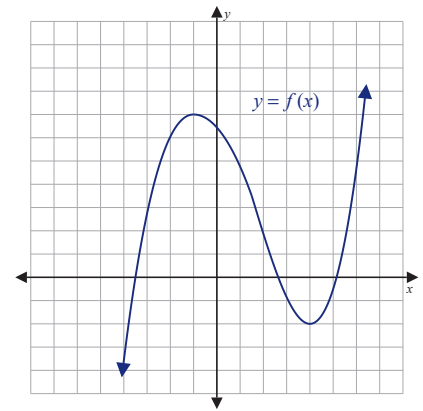

## Solution

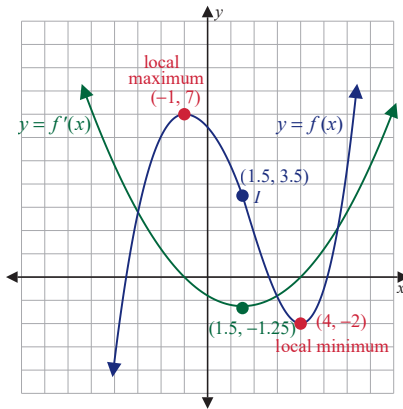

- A local maximum is located at  $(-1, 7)$ , and a local minimum is located at  $(4, -2)$ . There is a point of inflection at about  $(1.5, 3.5)$ .
- The function is increasing on the intervals  $(-\infty, -1)$  and  $(4, +\infty)$ . It is decreasing on the interval  $(-1, 4)$ . The function is concave downward on the interval  $(-\infty, 1.5)$  and concave upward on  $(1.5, +\infty)$ .
- The slope of  $f(x)$  is positive but decreasing from  $-\infty < x < -1$ , and is 0 at  $x = -1$ . The slope then becomes negative and continues decreasing until  $x = 1.5$  at which point slope is a minimum. Then the slope starts to increase from some negative value (which we estimate to be  $-1.25$ ) to 0 (at  $x = 4$ ). It then becomes positive and continues increasing.

## 4.3 EXERCISES

## PRACTICE

In Exercises 1–16, sketch the graph of a continuous function that satisfies all the given conditions.

- $f(-1) = 2$
  - $f'(-1) = 0$
  - $f'(x) < 0$  if  $x < -1$
  - $f'(x) > 0$  if  $x > -1$
  - $f''(x) > 0$  for all  $x$
- $f(3) = 4$
  - $f'(3) = 0$
  - $f''(x) < 0$  if  $x > 3$
  - $f''(x) > 0$  if  $x < 3$
  - $f'''(x) < 0$  for all  $x$
- $f(-2) = 4, f(-1) = 1, f(1) = -1$
  - $f'(-2) = 0, f'(1) = 0$
  - $f'(x) < 0$  if  $-2 < x < 1$
  - $f'(x) > 0$  if  $x < -2$  or  $x > 1$
  - $f'''(-1) = 0$
  - $f''(x) < 0$  if  $x < -1$
  - $f''(x) > 0$  if  $x > -1$
- $f(0) = -2, f(2) = 0, f(3) = 3$
  - $f'(0) = 0, f'(3) = 0$
  - $f''(x) < 0$  if  $x < 0$  or  $x > 3$
  - $f''(x) > 0$  if  $0 < x < 3$
  - $f''(2) = 0$
  - $f'''(x) < 0$  if  $x > 2$
  - $f'''(x) > 0$  if  $x < 2$

5. a.  $f(-3) = 5, f(-1) = 2, f(0) = -1$   
 b.  $f'(-3) = 0, f'(0) = 0$   
 c.  $f'(x) < 0$  if  $x < 0$  and  $x \neq -3$   
 d.  $f'(x) > 0$  if  $x > 0$   
 e.  $f'''(-3) = 0, f'''(-1) = 0$   
 f.  $f'''(x) < 0$  if  $-3 < x < -1$   
 g.  $f'''(x) > 0$  if  $x < -3$  or  $x > -1$
6. a.  $f(1) = 2, f(2) = 3, f(4) = 4,$   
 $f(6) = 2$   
 b.  $f'(1) = 0, f'(4) = 0$   
 c.  $f'(x) < 0$  if  $x > 4, x < 1$   
 d.  $f'(x) > 0$  if  $1 < x < 4$
7. a.  $f(x) = ax^3 + bx + c$   
 b.  $f(0) = 0$   
 c.  $f(1) = 15$   
 d.  $f'(-1) = 0$  and  $x = -1$  is a local max  
 e.  $f'''(x) > 0$  if  $x < 10$
8. a.  $f(10) = 5$   
 b.  $f'(5) = 0$   
 c.  $f''(5) = 10$   
 d.  $f''(x) < 0$  if  $x > 10$
9. a.  $f''(x) > 0$  if  $x < 5$   
 b.  $f''(5) = 0$   
 c.  $f''(x) < 0$  if  $x > 5$   
 d.  $f'(x) > 0$  for all  $x$
10. a.  $f(4) = 8$   
 b.  $f'(4) = 0$   
 c.  $f''(4) = 8$
11. a.  $f(-5) = 4$   
 b.  $f'(-5) = 0$   
 c.  $f''(-5) = -2$
12. a.  $f(x) = ax^2 + bx + c$   
 b.  $f'(-3) = 0$   
 c.  $f''(-3) = 2$
13. a.  $f(x) = ax^3 + bx^2 + cx + d$   
 b.  $f(0) = 25$   
 c.  $f'(4) = 0, f'(-4) = 0$   
 d.  $f''(4) = 48, f''(-4) = -48$
14. a.  $f(x) = ax^2 + bx + c$   
 b.  $f(0) = 79$   
 c.  $f'(5) = 0$   
 d.  $f''(x) = 6$
15. a.  $f(x) = ax^3 + bx^2 + cx + d$   
 b.  $f(0) = 2$   
 c.  $f'(0) = 5$   
 d.  $f''(0) = 4$   
 e.  $f'''(1) = 12$
16. a.  $f(x) = ax^3 + bx$   
 b.  $f'(0) = -12$   
 c.  $f'(2) = 0$

For each of the functions in Exercises 17–36, determine  $f'(x)$  and  $f''(x)$ . Then complete a summary table like those in Examples 3 and 4. Use this table to sketch the graph of the function. (If available, use a graphing calculator to obtain a suitable window and confirm the accuracy of your calculations.)

17.  $f(x) = x^2 - 4x + 7$
18.  $f(x) = x^2 + 6x - 8$
19.  $f(x) = 6 + 5x - x^2$
20.  $f(x) = 2 + 3x - 2x^2$
21.  $f(x) = x^3 + 3x^2 - 6$
22.  $f(x) = \frac{1}{3}x^3 - 4x + 3$
23.  $f(x) = \frac{1}{3}x^3 + x^2 - 3x + 5$
24.  $f(x) = 2x^3 - 3x^2 - 12x + 5$
25.  $f(x) = x^4 - 2x^2 + 4$
26.  $f(x) = x^4 - 8x^2 - 3$
27.  $f(x) = \frac{1}{4}x^4 - x^3 + 5$
28.  $f(x) = x^4 + 4x^3 + 12$
29.  $f(x) = x^4 - 4x + 7$
30.  $f(x) = 3x^4 - 4x^3 + 3$

31.  $f(x) = (x+5)(x-3)^2$
32.  $f(x) = (x+1)^2(x-10)^2$
33.  $f(x) = (2x+1)(x-8)^3$
34.  $f(x) = (x-5)(x-10)(x+3)$
35.  $f(x) = 2x(5x+8)^3$
36.  $f(x) = 16x(21+x)^3$
37. Suppose that  $f(x) = mx^2 + 6x + 4$ . Determine a value of  $m$  so that  $f(x)$  has a minimum at  $x = -1$ .
38. Given  $y = 4x^2 + nx + 8$ , determine a value for  $n$  so that  $y$  has a minimum at  $x = 2$ .
39. Determine a value for  $m$  such that at  $x = 1$  the tangent to the function  $f(x) = mx^2 + 6x + 1$  has an equation of  $y = 12x - 2$ .
40. Determine a value for  $m$  so that  $y = 4x^3 + mx^2$  has an inflection point at  $x = -10$ .

### APPLICATIONS

41. In an action movie, the hero is seen fighting the villain inside a plane, which has a large hole in its side. The hero (actually a movie stuntman) is then thrown from the plane. He falls quickly and soon reaches a constant velocity. The hero opens his parachute but it deploys slowly, as if he is having trouble, but finally, in triumph, all is well and he drifts steadily and slowly to the ground.
- Draw a graph of the hero's vertical distance to the ground, represented by  $y$ , versus time  $t$  (in seconds).
  - Describe any interesting points on the graph with points in the movie narrative.
42. The effectiveness of a certain medical injection is modeled by  $E(t) = 0.01t(100 - t)$ , where  $t$  is time in minutes and  $E$  is a measure of concentration in the bloodstream. Effectiveness readings above 9.0 are satisfactory and readings above 30 are dangerous.
- If an injection is given at midnight, when are the readings satisfactory? When do they become too low?
  - How high do the effectiveness readings get?
  - The supervising nurse and the resident pharmacologist must assign a schedule for injections. For the next week, assuming injected dosages are additive, give a reasonable schedule for injections so that the patient's  $E$ -reading stays at or above 9 but never exceeds 30.
43. The productivity rating of an individual worker at the Cruz Corporation assembly line is based on the number of tasks accomplished, mistakes made, and responsiveness to difficulties encountered. The average of all scores allows the company to use a simple model based on time on the floor given by  $PR = -0.4x^3 + 2x^2 + 10x + 5$ , where  $x$  is in hours at work. A PR score of 20 is acceptable and a score of 40 is highly unusual.
- When are workers' scores the highest?
  - Design an 8-hour day where workers do the most demanding jobs for about 6 hours and have 2 hours for less stressful work. Explain your reasoning.

 **WRITING & THINKING**

44. Is it possible for a polynomial  $y = ax^2 + bx + c$  to have an inflection point?

## 4.4 EXERCISES

 PRACTICE

For each of the rational functions in Exercises 1–12, find **a.** any vertical asymptotes, **b.** any horizontal asymptotes, and **c.** any oblique asymptotes.

1.  $f(x) = \frac{1}{x-4}$

2.  $f(x) = -\frac{3}{x+6}$

3.  $f(x) = \frac{2x}{x+8}$

4.  $f(x) = \frac{5x}{2x+1}$

5.  $f(x) = \frac{x+2}{x^2+1}$

6.  $f(x) = \frac{x-7}{x^2+3}$

7.  $f(x) = \frac{5x^2}{3x^2-2x-1}$

8.  $f(x) = \frac{2x^2}{x^2+3x}$

9.  $f(x) = \frac{x^2-4}{x}$

10.  $f(x) = \frac{3x^2+2}{x}$

11.  $f(x) = \frac{x^2+1}{x+1}$

12.  $f(x) = \frac{x^2-5}{x-2}$

In Exercises 13–22, sketch the graph of each rational function. Show any asymptotes on each graph.

13.  $f(x) = -\frac{2}{x+5}$

14.  $f(x) = \frac{4}{x-3}$

15.  $f(x) = \frac{2x}{x+1}$

16.  $f(x) = \frac{3x}{x-2}$

17.  $f(x) = \frac{x-2}{x-1}$

18.  $f(x) = \frac{x+4}{2x+1}$

19.  $f(x) = 2x + \frac{2}{x}$

20.  $f(x) = 3x + \frac{12}{x}$

21.  $f(x) = \frac{3x^2+6}{x}$

22.  $f(x) = \frac{2x^2+1}{3x}$

 APPLICATIONS

23. Junker Renovation completely overhauls junked or abandoned cars. Data shows their 1970s models hold their value quite well. The value  $F(x)$  of one of these cars is given by  $F(x) = 70 - \frac{15x}{x+1}$  where  $x$  is the number of years since repurchase and  $F$  is in hundreds of dollars.

- What is the initial resale price of a car?
- Find all asymptotes.
- Sketch the function.
- What is the long-term value of one of these cars?

24. The average cost  $A(x)$  is the total cost  $C(x)$  divided by the quantity  $x$ . Thus  $A(x) = \frac{C(x)}{x}$ . If the total cost function for a product is  $C(x) = 3x + 12$ , graph the average cost  $A(x)$ . If there are any asymptotes, locate them and interpret their meaning.

25. A product's total costs are given by  $C(x) = 0.03x^2 + 24x + 10$ .
- Graph the average cost function, locating any asymptotes.
  - What is the meaning of the asymptotes for average cost?
26. The Polar Pollution Control Company removes debris from old motors. Suppose the cost  $F(x)$  of removing  $x$  percent of the pollutants is given by  $F(x) = \frac{100,000}{100-x}$ , where  $x$  is a percentage,  $0 \leq x < 100$ , and  $F$  is in dollars.
- Determine  $\lim_{x \rightarrow 0^+} F(x)$  and  $\lim_{x \rightarrow 100^-} F(x)$  and interpret their meanings.
  - What percentage can be removed at a cost of \$3000?
  - Show that  $F(x)$  is always increasing. Does this make sense in the context of the problem?
27. The cost of camel rides in Tunisia is modeled by the function  $F(x) = 40 - \frac{20x}{x+3}$ , where  $x$  is the number of years since 2000 and  $F$  is a national average cost in dinars.
- What was the cost of a camel ride in 2002?
  - What are the asymptotes for  $F$  and which is significant in the problem?
  - When was the average cost 26 dinars?
28. The sugar level concentration in the bloodstream of a certain diabetes patient is modeled by  $S(t) = 1 + \frac{0.2t}{t^2 + 2}$ , where  $S$  is in suitable units and  $t$  is the time in hours following a meal of allowed carbohydrate content.
- Which asymptotes play a role here?
  - For  $0 \leq t \leq 6$ , what is the highest  $S$ -value and when does it occur? (If this level exceeds 4, the patient will become ill.)
  - Are there any inflection points? What is the meaning in the context of the problem of an inflection point?
29. Data suggests a professional football team will win  $F(x)$  games (out of 17) if the salary of the superstar players increases. For one team, the function  $F$  is given by  $F(x) = 8 + \frac{6x - 96}{0.125x^2 - 4x + 34}$ , where  $x$  is the average salary (in millions) of the superstars (players earning at least one million dollars).
- Are there any asymptotes of consequence in the problem?
  - What average salary gives the biggest return on games won, according to this model? (Here return is total games won.)
30. If administrative assistants at Bookworm Publications make phone follow-ups after textbook reviews, more colleges and universities will adopt a new statistics book. The publisher noticed that new book sales varied in the second year according to  $S(x) = A_0 - \frac{(x+200)}{x^2}$ , where  $S$  is total sales and  $x$  is the number of phone calls made to colleges which have adopted the book.  $A_0$  denotes the sales from the previous year.
- Assuming  $A_0 = 2500$ , what sales can Bookworm Publications expect if they make 100 follow-up phone calls?
  - What is the horizontal asymptote and what is its significance?

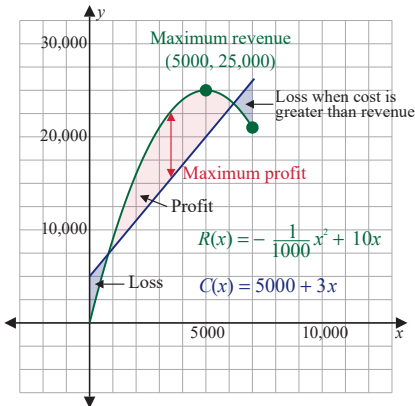

Thus, a maximum profit occurs if the company produces and sells 3500 calculators, which is only half its production capabilities. The price for each calculator would be

$$p = -\frac{1}{1000}(3500) + 10 = \$6.50.$$

The graph shown illustrates the relationship between profit, revenue, and cost. Note that maximum revenue and maximum profit do not necessarily occur at the same level of production and sales.

## 4.5 EXERCISES

### APPLICATIONS

- Minimizing inventory costs:** An appliance store owner estimates that he will sell 125 vacuum cleaners of a particular model. It costs \$12 to store one vacuum cleaner for one year. There is a fixed cost of \$30 for each order. Find the lot size and the number of orders per year that will minimize inventory costs.
- Minimizing inventory costs:** A hardware store sells 96 chainsaws per year. It costs \$5 to store one chainsaw for one year. There is a fixed reordering cost of \$15. Find the lot size and the number of orders per year that will minimize inventory costs.
- Minimizing inventory costs:** An art gallery owner expects to sell 90 copies of a limited-edition print during the next year. It costs \$1.50 to store one copy for one year. For each order she places, there is a fixed cost of \$7.50, plus \$0.50 for each copy. Find the lot size and the number of times the gallery owner should order per year to minimize her inventory costs.
- Minimizing inventory costs:** The owner of Lamps-4-U expects to sell 180 brass lamps during the year. For each order he places, there is a fixed cost of \$18, plus \$2 for each lamp ordered. It costs \$5 to store one lamp for one year. In what lot size and how many times per year should he reorder to minimize the inventory costs?
- Minimizing inventory costs:** A T-shirt company sells 4000 sweatshirts per year. To reorder, there is a fixed cost of \$6 plus \$0.80 for each sweatshirt. It costs \$1.20 to store one sweatshirt for one year. In what lot size and how many times per year should an order be placed to minimize inventory costs?
- Minimizing inventory costs:** An office supply store sells 7500 pink highlighters per year. It costs \$0.15 to store one pink highlighter for one year. To reorder these highlighters, there is a fixed cost of \$22.50, plus \$0.10 for each highlighter. In what lot size and how many times per year should an order be placed to minimize inventory costs?
- Minimizing inventory costs:** A snowmobile dealer in Minnesota expects to sell 960 snowmobiles during the next year. It costs \$9 to store one snowmobile for one year. To reorder, there is a fixed cost of \$67.50, plus \$7.50 for each snowmobile. In what lot size and how many times per year should an order be placed to minimize inventory costs?

8. **Minimizing inventory costs:** A car dealer expects to sell 1320 cars during the next year. It costs \$660 to store one car for one year. To reorder, there is a fixed cost of \$225, plus \$304 for each car. Find the lot size and the number of orders that should be placed so inventory costs will be minimized.
9. **Maximizing revenue:** A chain of discount stores sells 84 weather radios per month at \$20 each. The owners estimate that for each \$1 increase in price, they will sell 3 fewer radios per month. How much should they charge for their weather radios to maximize their revenue?
10. **Maximizing revenue:** A farmer estimates that if he plants 30 grapefruit trees per acre, the average yield per tree will be 480 pounds. For each additional tree planted per acre, the yield per tree will be reduced by 12 pounds. How many trees should be planted per acre to maximize the yield?
11. **Maximizing revenue:** Sam operates a chain of convenience stores. He estimates that he can sell 600 small packs of gum per day if he charges 75 cents each. Sam determines that for each 10-cent reduction in price, he will sell an additional 80 packs per day. How much should he charge for the small packs of gum to maximize his revenue?
12. **Maximizing revenue:** A sporting goods store sells 200 baseball gloves per month at \$36 each. The owner estimates that for each \$2 increase in price, he will sell 5 fewer gloves. Find the price that will maximize revenue.
13. **Maximizing revenue:** A sports arena has 40 roaming soda salespeople, each of whom sells 200 sodas per event. Management estimates that for each additional salesperson, the yield per salesperson decreases by 4. How many additional salespeople should management hire to maximize the number of sodas sold?
14. **Maximizing revenue:** Ms. Wills owns a 16-rack dry stack boat storage facility. The unit rent per rack is currently \$400 per month, and all racks are rented. Each time rent is increased by \$20, one boat owner will move out. Find the rental price that will maximize Ms. Wills' revenue.
15. **Linear demand function:** A local amusement park found that if the admission was \$7, about 1000 customers per day were admitted. When the admission was dropped to \$6, the park had about 1200 customers per day. Assuming a linear demand function, determine the admission price that will yield maximum revenue.
16. **Linear demand function:** A department store manager has determined that when the price of a tank top was \$12, she sold 100 tank tops per month. However, only 80 tank tops were sold per month when the price was raised to \$14. Assuming a linear demand function, determine the price that would maximize the revenue.
17. **Linear demand function:** The cost of producing  $x$  units of an item is  $C(x) = 10x + 20$ . When the selling price is \$20, twenty-one items are sold. However, when the price is \$16, twenty-three items are sold. Assuming the demand function is linear, determine the price per unit and the number of units sold that will maximize the profit.

- 18. Linear demand function:** The manager of a bakery knows he can sell 60 small bags of donut holes when the price is \$1.20 each. If the price is \$1.50, only 48 bags are sold. The total cost function for  $x$  bags is  $C(x) = 0.70x + 15$  dollars. Assuming a linear demand function, determine the price per bag and the number of bags sold that will maximize the profit.
- 19. Linear demand function:** The manufacturer of microwave ovens can sell 800 to his dealers at \$392 each. If the price is \$380, he can sell 1000. The total cost of producing  $x$  microwaves is  $C(x) = 3600 + 250x - 0.01x^2$  dollars. Assuming the demand function is linear, find the price per microwave and the number of microwaves sold that will maximize profit.
- 20. Linear demand function:** A candy store can sell 180 lollipops at 62 cents each. The store can sell 220 lollipops if the price is 54 cents each. The total cost of producing  $x$  lollipops is  $C(x) = 3050 - 10x + 0.04x^2$  cents. Find the number of lollipops that should be produced to maximize profit.
- 21. Profit:** Suppose  $P(x)$  represents profit on the sales of  $x$  cell phones. Suppose  $P(25,000) = 12,000$ ,  $P'(25,000) = 2$ , and  $P''(25,000) = -3$ .
- Is the company making money or losing it? How much?
  - If sales are increased, will the profits rise or fall? By how much?
  - What is the meaning of  $P''(25,000) = -3$ ?
- 22. Profit:** Suppose the monthly marginal profit from John's online tutoring service is  $P'(x) = 3$ , where  $x$  is the number of subscribers.
- The profit function is (choose one): linear, quadratic, or a polynomial of degree 3 or higher.
  - Suppose monthly costs are  $C(x) = 9x + 20$ . Assuming initial revenue is 0, what is the revenue function?
- 23. Profit:** Suppose the demand for a product is \$12 and the total costs are  $C(x) = 0.3x^2 + 2x + 5$ .
- What is the revenue function?
  - What is the profit function?
  - What is the maximum value of the profit?
- 24. Average cost:**  $A(x) = \frac{C(x)}{x}$  gives average cost.
- Calculate a formula for  $A'(x)$ .
  - Set  $A'(x) = 0$  and solve for  $C'(x)$ .
  - If average costs are minimal, describe a relationship between average cost and marginal cost. That is, interpret the result of part **b**.
- 25. Average cost:** Suppose that a company's average cost is  $A(x) = 0.2x + 3$ .
- Determine the cost function.
  - Determine the marginal average cost.
  - Determine the marginal cost.

- 26. Earnings:** Suppose a company's earnings are given by  $E(x) = P(x) + I(x)$ , where  $x$  is the number of years since 2018,  $P(x)$  is the annual profit function, and  $I(x)$  is the intangible growth (the growth in value of the company's intangible assets such as its good name). If  $P(x) = 1.3x + 2$  and  $I(x) = 0.25x + 1$  for a certain company, determine the following.
- The marginal earnings for year  $x$
  - The actual earnings for 2020
  - The average earnings formula (earnings per year since 2018)
- 27. Value:** The value of a new business franchise grows according to the formula  $V(x) = 10 + \frac{10x}{1+0.5x}$ . Here  $V$  is in thousands of dollars and  $x$  is the number of years after 2012.
- What is the expected value in 2022?
  - Is the value  $V$  increasing or decreasing in 2022?
  - Is the rate of increase in value changing? What has this to do with  $V'$  or  $V''$ ?
- 28. Value:** The timber value of a small stand of pine trees is given by  $V(x) = 50\left(1 - \frac{1}{x+2}\right)$ , where  $x$  is the number of years after 2000 and  $V$  is in dollars.
- What was the value in 2000?
  - At what rate was the value changing in 2010?
  - What asymptotes are present and what is their significance in the problem?



### WRITING & THINKING

- 29. Sales function:** A sales function  $S(t)$  for a new product is shown in the figure.  $S(t)$  is total sales (quantity of items) and  $t$  is time in months since the product's release. Copy this graph onto your paper and add a graph of a possible  $S'(t)$ . Locate approximately the point of inflection on your curve for  $S$ .

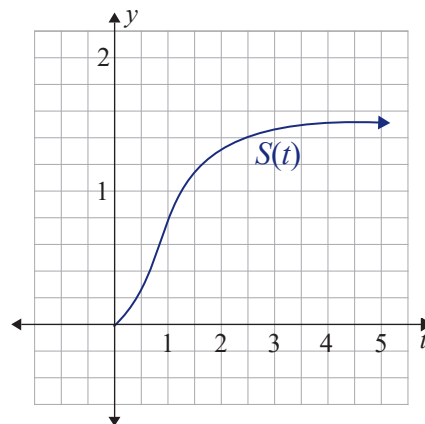

- 30. Cost function:** A certain cost function  $C(x)$  satisfies  $C(10) = 20$ ,  $C(20) = 40$ , and  $C(30) = 60$ . Suppose  $C''(10) = -2$ ,  $C''(20) = 0$ , and  $C''(30) = 2$ . Draw a suitable function.

- b. The projectile hits the ground when  $s(t) = 0$ .

$$-16t^2 + 160t + 176 = 0$$

Solve  $s(t) = 0$  for  $t$ .

$$-16(t^2 - 10t - 11) = 0$$

$$-16(t - 11)(t + 1) = 0$$

$$t = 11 \text{ or } \cancel{t = -1}$$

Time cannot be negative, so we discard the  $t = -1$ .

Thus the projectile hits the ground 11 seconds after it is fired.

- c. The projectile's velocity when it hits the ground is  $v(11)$ . From part a. we know

$$v(t) = -32t + 160.$$

So

$$v(11) = -32(11) + 160$$

$$= -352 + 160$$

$$= -192 \text{ ft/sec.}$$

The negative sign indicates the projectile is falling.

The projectile will be falling at a rate of 192 ft/sec when it hits the ground.

## 4.6 EXERCISES

### APPLICATIONS

- Volume of a box:** A rectangular box with no top is to be made from a piece of cardboard that is 24 in. by 24 in. Equal squares are to be cut from each corner and the sides folded to form the box. What size should the squares be to maximize the volume of the box?
- Volume of a box:** A rectangular box with no top is to be made from a piece of cardboard that is 20 in. by 20 in. Equal squares are to be cut from each corner and the sides folded to form the box. What size should the squares be to maximize the volume of the box?
- Volume of a box:** Equal squares are to be cut from each corner of a rectangular piece of thin sheet metal, and the sides are to be folded to form a box. If the piece of metal is 8 in. by 15 in., find the dimensions of the box having maximum volume.
- Volume of a box:** Equal squares are to be cut from each corner of a rectangular piece of thin sheet metal, and the sides are to be folded to form a box. If the piece of metal is 10 in. by 16 in., find the dimensions of the box having maximum volume.
- Surface area:** A rectangular box is designed to have a square base and an open top. The volume is to be 864 in.<sup>3</sup>
  - What dimensions will give a minimum surface area?
  - What is the minimum surface area?

6. **Surface area:** A rectangular box is designed to have a square base and an open top. The volume is to be  $256 \text{ in.}^3$
- What dimensions will give a minimum surface area?
  - What is the minimum surface area?
7. **Container design:** A container manufacturer is asked to design a closed rectangular shipping crate with a square base. The volume is  $10 \text{ ft}^3$ . The material for the top and sides costs \$2 per square foot and the material for the bottom costs \$3 per square foot. Find the dimensions of the box that will minimize the total cost.
8. **Container design:** A container manufacturer is asked to design a closed rectangular shipping crate with a square base. The volume is  $36 \text{ ft}^3$ . The material for the top costs \$1 per square foot, the material for the sides costs \$0.90 per square foot, and the material for the bottom costs \$1.40 per square foot. Find the dimensions of the box that will minimize the total cost of material.
9. **Container design:** An investor plans to manufacture rectangular box containers whose bottom and top measure  $x$  by  $3x$ . The box must contain 18 cubic feet. The top and bottom will cost \$2 per square foot, and the four sides will cost \$3 per square foot. What should the height  $h$  be so as to minimize costs?
10. **Area:** A rectangular plot is to be enclosed with an existing block wall as one side. If there are 680 ft of fencing available for the other three sides, find the dimensions that will maximize the area.
11. **Area:** A rectangular play area is to be enclosed with the side of a house as one of the sides. If there are 74 ft of fencing available for the other three sides, find the dimensions that will maximize the area.

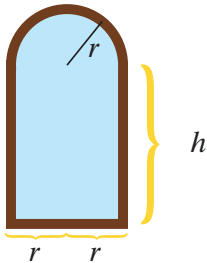

12. **Window area:** A front window on a new home is designed as a rectangle with a semicircle on the top. If the window is designed to let in a maximum amount of light, and the architect fixes the perimeter of the entire window at 600 inches, determine the radius  $r$  and rectangular height  $h$  so as to maximize the area.
13. **Wall construction:** An old stone wall makes two legs of a right angle, one 40 feet long and the other 20 feet long. A constructor is told to add 220 feet of new stone fence to complete a rectangular fence. How should he complete the fence so as to maximize the enclosed area? Determine the maximum enclosed area he may obtain.

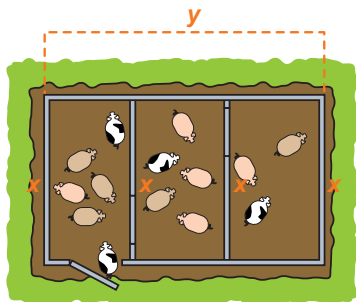

14. **Construction:** A warehouse is being constructed with a total floor area of  $2200 \text{ ft}^2$ . A single partition is built to divide the building into storage area and office space. The exterior walls cost \$160 per foot, and the interior wall costs \$120 per foot. Find the dimensions of the warehouse that will minimize the cost.

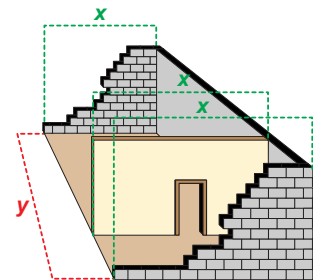

15. **Construction:** A farmer wants to build a rectangular pen and then divide it with two interior fences. The total area is to be  $2484 \text{ ft}^2$ . The exterior fence costs \$18 per foot, and the interior fence costs \$16.50 per foot. Find the dimensions of the pen that will minimize the cost.

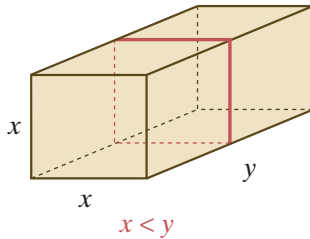
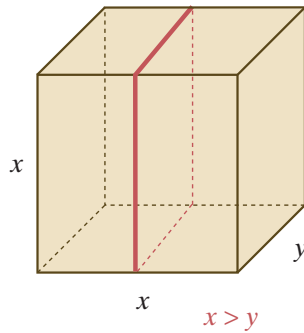

**16. Shipping:** The Postal Service has a limit of 108 in. on the combined length and girth of a rectangular package to be sent by parcel post. Find the dimensions of the package of maximum volume that has a square cross section. (**Hint:** There are two different answers, depending on the shape of the box. The two shapes are shown here. The girth is defined to be the smallest perimeter of a rectangular cross section of the box.)

**17. Shipping:** An independent parcel service has a limit of 130 in. on the combined length and girth of a rectangular package it will ship. Find the dimensions of the package of maximum volume that has a square cross section. (**Hint:** There are two different answers. The girth is defined to be the smallest perimeter of a rectangular cross section of the box.)

**18. Pipeline construction:** An oil company wishes to run a pipeline from a drilling platform located 5 miles offshore to a shipping terminal 16 miles down the coast. The costs are \$130,000 per mile to lay the pipeline underwater and \$120,000 per mile to lay the pipeline over land. Find the location of point P (as illustrated in the diagram) so that the total cost of laying pipe will be minimized.

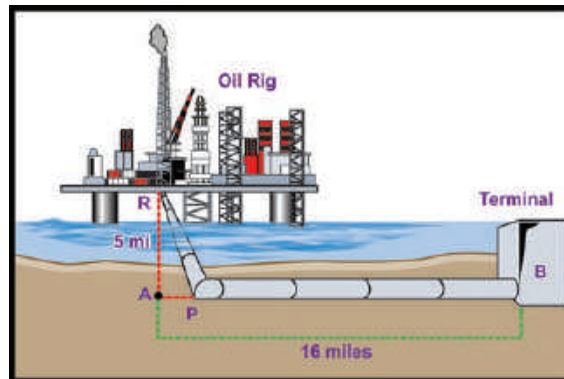

**19. Power line construction:** The U.S. Forest Service wishes to run a power line to a fire lookout tower located in a wooded area. The tower is 4 miles from the nearest road and the power source is 7 miles down that road. It costs \$5000 per mile to run the line through the forest and \$3000 per mile to run the line along the road. Find the location of point P (as illustrated in the diagram) so that the total cost of running the power line will be minimized.

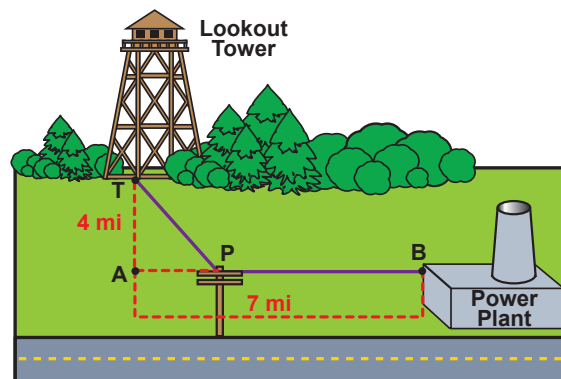

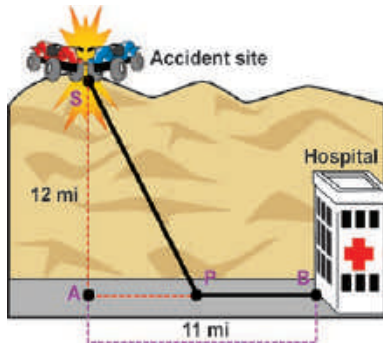

20. **Minimum time:** The Off-Roaders, an all-terrain vehicle club, were driving their four-wheelers in the desert when one member had a serious accident. At the time, they were 12 miles from the nearest paved road. The nearest hospital was located 11 miles down the paved road. If they can average 20 mph on the desert and 52 mph on the road, locate point P on the road toward which they should drive in order to minimize the time needed to get to the hospital.
21. **Minimum time:** A man is on the bank of a river that is 0.6 miles wide. He wants to reach a point on the opposite shore that is 1.5 miles downstream. If he can row a boat across the river at 4 mph and walk at 5 mph, find the location P, on the opposite shore, to which he should row in order to minimize the total time he would need to reach the point downstream.

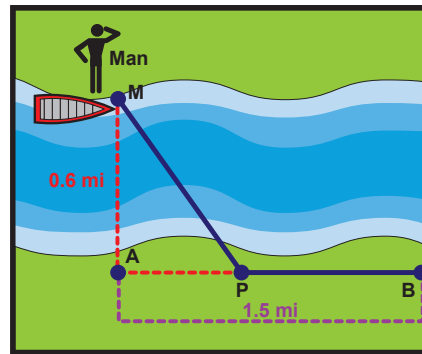

22. **Distance and velocity:** A particle is moving along a straight line such that the distance traveled at the end of  $t$  seconds is given by  $s(t) = 7t^2 + 30t$  feet.
- Find the velocity if  $t = 2$  seconds.
  - How far has the particle traveled?
23. **Distance and velocity:** A ball is rolled down an incline. The distance (in feet) of the ball from the starting point after  $t$  seconds is given by  $s(t) = 19t + 8t^2$ .
- Find the velocity after 3 seconds.
  - How far has the ball traveled in 3 seconds?
24. **Distance and velocity:** A projectile is fired vertically, and its height (in feet) after  $t$  seconds is given by  $s(t) = 104t - 16t^2$ .
- Find the maximum height of the projectile.
  - When does the projectile hit the ground?
  - How fast is the projectile moving when it hits the ground?
25. **Distance and velocity:** A stone is projected vertically. The height (in feet) of the stone at time  $t$  (in seconds) is given by  $s(t) = -16t^2 + 112t + 128$ .
- What is the maximum height of the stone?
  - When will the stone hit the ground?
  - What is the speed of the stone when it hits the ground?
26. **Distance and velocity:** A child rolls a hoop down a hilly street. The distance traveled (in feet) after  $t$  seconds is given by  $s(t) = 4t + t^2$ .
- How far has the hoop traveled in 3 seconds?
  - What was the speed at 3 seconds?
  - At what rate was the speed changing at  $t = 3$ ?

## 4.7 EXERCISES

 PRACTICE

Find the differential for each of the functions in Exercises 1–14.

1.  $y = x^3 + 5$

2.  $y = 4x^3 + x - 7$

3.  $u = (2t^2 + 1)^2$

4.  $u = (5t + 9)^2$

5.  $A = \pi r^2$

6.  $A = x(44 - 2x)$

7.  $V = \frac{4}{3}\pi r^3$

8.  $V = x^3$

9.  $S = 4x^2 + \frac{1350}{x}$

10.  $C = 75 + 10x - 0.6\sqrt{2x}$

11.  $C = 40 + 3x + 0.4\sqrt{x}$

12.  $S = 2\pi r^2 + \frac{90\pi}{r}$

13.  $P = -0.2x^2 + 75x - 2400$

14.  $P = -0.3x^2 + 84x - 870$

For each of the functions given in Exercises 15–22, use the given values for  $x$  and  $\Delta x$  to find **a.**  $\Delta y$ , **b.**  $dy$ , and **c.**  $\Delta y - dy$ .

15.  $y = x^2 - 3x + 4$ ,  $x = 3$ ,  $\Delta x = 0.2$

16.  $y = x^2 + 5x - 9$ ,  $x = 2$ ,  $\Delta x = 0.15$

17.  $y = (2x^2 - 4)^3$ ,  $x = -2$ ,  $\Delta x = 0.04$

18.  $y = (x^2 + x - 1)^3$ ,  $x = -3$ ,  $\Delta x = 0.05$

19.  $y = 20\left(x - \frac{24}{x}\right)$ ,  $x = 2$ ,  $\Delta x = -0.12$

20.  $y = 2x^2 + \frac{125}{x^2}$ ,  $x = 5$ ,  $\Delta x = -0.15$

21.  $y = \sqrt{3x + 4}$ ,  $x = 7$ ,  $\Delta x = 0.5$

22.  $y = \sqrt{12 - 5x}$ ,  $x = 2$ ,  $\Delta x = 0.07$

Use differentials to approximate the indicated roots in Exercise 23–30. Express your answer as  $a \pm \frac{b}{c}$ , where  $a$  is the nearest integer.

23.  $\sqrt{37}$

24.  $\sqrt{65}$

25.  $\sqrt[3]{26}$

26.  $\sqrt[3]{126}$

27.  $\sqrt{50.4}$

28.  $\sqrt{79.5}$

29.  $\sqrt[3]{62.3}$

30.  $\sqrt[3]{218.3}$

 APPLICATIONS

**31. Cost:** A total cost function (in dollars) is given by  $C(x) = 375 + 9x + 0.01x^2$ . Use differentials to estimate the change in cost when the level of production is increased from 60 to 62 units.

**32. Cost:** A total cost function (in dollars) is given by  $C(x) = 930 + 15x + 0.2x^2$ . Using differentials, estimate the change in cost from  $x = 100$  to  $x = 101$ .

**33. Profit:** The weekly revenue (in dollars) from the sale of  $x$  coffee makers is given by  $R(x) = 40x$ . The total cost function is given by  $C(x) = 370 + 16x + 0.2x^2$ . Use differentials to approximate the change in profit if the weekly sales are increased from 25 to 28 coffee makers.

- 34. Profit:** The monthly revenue from the sale of  $x$  50-gallon aquariums is given by  $R(x) = 54x - 0.3x^2$  dollars. The total cost function is given by  $C(x) = 0.1x^2 + 4x + 200$  dollars. Using differentials, find the approximate change in profit if the monthly sales are increased from 40 to 44 aquariums.
- 35. Population:** It is estimated that  $t$  years from now the population of a city will be  $P(t) = 10(4000 + 2t^2) - 1600t$ . Use differentials to estimate the change in population as  $t$  changes from 6 to 6.25 years.
- 36. Bacterial population:** It is estimated that  $t$  hours from now the population of bacteria in a culture will be  $P(t) = \frac{8000}{\sqrt{8 - 0.5t}}$ . Use differentials to estimate the change in population as  $t$  changes from 8 to 8.3 hours.
- 37. Volume:** The edge of a cube measures 18 in. with a possible error in measurement of 0.02 in. Use differentials to estimate the possible error in computing the volume.
- 38. Fiberglass coating:** A cube is 12 in. on a side. It is to be covered with a fiberglass coating 0.25 in. thick. Use differentials to estimate the volume of the fiberglass coating.
- 39. Measurement error:** A manufacturer of cargo containers receives an order for a cube-shaped container. The specifications state that the volume should be  $125 \text{ ft}^3$ , with a maximum error of no more than  $1 \text{ ft}^3$ . Using differentials, find the possible error in the length of the edges.
- 40. Melting ice:** A block of ice is in the form of a 10 in. cube. If it melts uniformly until the volume changes to  $972 \text{ in.}^3$ , approximate the change in the length of each edge by using differentials.
- 41. Volume of a weather balloon:** A spherical weather balloon is being inflated. Use differentials to find the approximate change in the volume if the radius changes from 20 to 21.5 inches. (**Hint:**  $V = \frac{4}{3}\pi r^3$ .)
- 42. Volume of a tumor:** A spherical cancer tumor is being treated with an experimental drug. The radius of the tumor has been reduced from 1.6 to 1.4 cm. Use differentials to estimate the change in the volume of the tumor. (**Hint:**  $V = \frac{4}{3}\pi r^3$ .)

So far, we have used the formula  $A = Pe^{rt}$  to calculate the future value  $A$  of an account that will result from an investment  $P$  in the present. Now, suppose we know the future value to be accumulated and would like to determine how much should be deposited today to guarantee that future amount. We solve the formula  $A = Pe^{rt}$  for  $P$  to obtain

$$P = Ae^{-rt}.$$

We call  $P$  the **present value** of  $A$ .

#### Example 4: Initial Deposit Amount

Suppose that the grandparents of a child would like to make a one-time investment now to help pay for the child's college education in 20 years. How much should they deposit in an account earning 10 percent interest compounded continuously, so that the value of the account will accumulate to \$20,000?

#### Solution

$$\begin{aligned} P &= Ae^{-rt} \\ &= 20,000e^{-0.10 \cdot 20} && \text{We use } A = 20,000, r = 0.10, \text{ and } t = 20. \\ &\approx 20,000(0.135335283) \\ &\approx \$2706.71 \end{aligned}$$

That is, \$2706.71 (invested at 10 percent compounded continuously for 20 years) is the present value of \$20,000.

## 5.1 EXERCISES

### PRACTICE

Use a calculator to evaluate the expressions in Exercises 1–8. Round your answers to the nearest hundredth.

1.  $10^{2.3}$
2.  $2^{1.5}$
3.  $e^{-0.5}$
4.  $e^{2.1}$
5.  $e^3$
6.  $e^{-1}$
7.  $2e^{-1.6}$
8.  $3e^{2.5}$
9. Let  $f(x) = 9^{\frac{x}{2}}$ .
  - a. Find  $f(0)$ .
  - b. Find  $f(1)$ .
  - c. Find  $f(3)$ .
10. For  $y = -2e^{x^2+1}$ , find the value of  $y$  (rounded to two decimal places) if
  - a.  $x = 1$ ,
  - b.  $x = 0$ ,
  - c.  $x = -1$ .

Graph each of the functions in Exercises 11–26.

- |                      |                      |                                      |                                      |
|----------------------|----------------------|--------------------------------------|--------------------------------------|
| 11. $y = 4^x$        | 12. $y = 5^x$        | 13. $y = \left(\frac{2}{3}\right)^x$ | 14. $y = \left(\frac{1}{4}\right)^x$ |
| 15. $y = 3^{-2x}$    | 16. $y = 2^{-3x}$    | 17. $y = 2^{x-1}$                    | 18. $y = 2^{x+1}$                    |
| 19. $y = 3e^x$       | 20. $y = 2e^{-x}$    | 21. $y = e^{-1.5x}$                  | 22. $y = e^{2x}$                     |
| 23. $y = 6e^{-0.5x}$ | 24. $y = 10e^{0.5x}$ | 25. $y = e^{-x^2}$                   | 26. $y = 5e^{-x^2}$                  |

### APPLICATIONS

27. **Compound interest:** Suppose that \$5000 is invested at an annual interest rate of 6 percent for 4 years. Find the total amount available if the interest is compounded:
- |                  |                                 |
|------------------|---------------------------------|
| a. annually,     | b. semiannually,                |
| c. quarterly,    | d. daily (using 360 days/year), |
| e. continuously. |                                 |
28. **Compound interest:** Suppose that \$3000 is deposited in a saving account at the rate of 8 percent per year. Find the total amount available at the end of 5 years if the interest is compounded:
- |                  |                                 |
|------------------|---------------------------------|
| a. annually,     | b. semiannually,                |
| c. quarterly,    | d. daily (using 360 days/year), |
| e. continuously. |                                 |
29. **Compound interest:** How much money must be deposited in a savings account that pays interest at a rate of 7 percent per year compounded quarterly so that after 5 years the balance will be \$12,000?
30. **Compound interest:** Matt's father is planning to open a savings account to help pay for Matt's college education. He has found a bank that will pay 8 percent interest compounded monthly. How much will he need to deposit initially so that in 4 years the balance will be \$20,000?
31. **Compound interest:** Maggie has \$8000 to invest for 2 years. She has two different accounts she can use. One account will pay 8 percent interest compounded monthly. The other account will pay 7.5 percent compounded continuously. Which is the better investment, and by how much?
32. **Reliability:** The reliability of a certain type of flashlight battery is given by  $f(t) = e^{-0.05t}$ , where  $f$  is the fraction of the batteries that last  $t$  hours. What fraction of the batteries produced are still working after 20 hours of use?
33. **Drug concentration:** The concentration of a certain drug in the body fluids is given by  $C = C_0 e^{-0.4t}$ , where  $C_0$  is the initial dose and  $t$  is the time in hours elapsed after the dose is administered. If 20 mg of the drug is given, how much of the drug will remain in the body after 8 hours?
34. **Bee population:** A colony of bees grows according to the formula  $P = P_0 e^{0.18t}$ , where  $P_0$  is the number of bees present initially and  $t$  is the time in days. How many bees will be present after 6 days if there were 1200 bees initially?

- 35. Advertising:** A radio station estimates that during an intense advertising campaign, the total number of people  $N$  who will hear a commercial is given by  $N = A(1 - e^{-0.03t})$ , where  $A$  is the number of people in the broadcasting area and  $t$  is the number of hours after the first time the commercial is run. If there are 500,000 people in the area, how many will hear the commercial during the first 20 hours of the ad campaign?
- 36. Reliability:** Studies show that the fraction  $P$  of light bulbs that have burned out after  $t$  hours of use is given by  $P = 1 - e^{-0.03t}$ . What fraction of the bulbs have burned out after 24 hours?
- 37. Depreciation:** The value  $V$  of a machine at the end of  $t$  years is given by  $V = C(1 - r)^t$ , where  $C$  is the original cost of the machine and  $r$  is the rate of depreciation. Find the value at the end of 6 years of a machine that costs \$8400 if  $r = 0.15$ .
- 38. Depreciation:** The value  $V$  of a machine at the end of  $t$  years is given by  $V = C(1 - r)^t$ , where  $C$  is the original cost of the machine and  $r$  is the rate of depreciation. A machine that is 5 years old is valued at \$4000. If the rate of depreciation is 12 percent, find the original cost of the machine.
- 39. Present value:** Mr. and Mrs. Jackson want to accumulate another \$50,000 as part of their retirement fund in 15 years with a one-time deposit now. If the interest is to be figured at 8 percent compounded continuously, what should the Jacksons' initial deposit be?
- 40. Present value:** If a trust fund is designed to have a value of \$600,000 in 25 years and interest is compounded continuously at 9 percent, what is the present value of this amount?

### Example 5: Continuous Compounding Interest

The formula  $A = Pe^{rt}$  represents the amount accumulated when a principal is compounded continuously (as discussed in Section 5.1). How long will it take a principal  $P$  to double if interest is compounded continuously at 10 percent?

#### Solution

If  $P$  is doubled, then the amount  $A$  is  $2P$ .

$$\begin{aligned} Pe^{0.10t} &= 2P & r &= 10\% = 0.10 \\ e^{0.10t} &= 2 \\ 0.10t &= \ln 2 \\ t &= \frac{\ln 2}{0.10} \approx \frac{0.6931}{0.10} = 6.931 \end{aligned}$$

The principal will double in approximately 6.9 years.

So far we discussed the natural logarithms and we saw that  $y = e^x$  and  $y = \ln x$  are inverse functions.

Now, suppose  $B$  is a positive number and  $B > 1$ . The exponential function with base  $B$ , specifically  $f(x) = B^x$ , has an inverse function, and we denote this inverse by  $f^{-1}(x) = \log_B x$ . The inverse is the **logarithmic function with base  $B$** . It follows that  $B^{\log_B x} = x$  and  $\log_B(B^x) = x$ .

Note that  $\log_{10} x$  is called the **common logarithm**, and is usually written  $\log x$ .

Historically, the natural logarithms (base  $e$ ) and common logarithms (base 10) have proved sufficient for computations and most theoretical purposes. For this reason, tables for base  $e$  and base 10 are built into all graphing calculators. Such calculators normally have a button labeled “ln” for the natural logarithm and a button labeled “log” for the common logarithm.

## 5.2 EXERCISES

### PRACTICE

In Exercises 1–6, write each exponential equation as a logarithmic equation.

- $e^{0.5} \approx 1.648721$
- $e^{1.6} \approx 4.953032$
- $e^{-2.1} \approx 0.122456$
- $e^{-0.3} \approx 0.740818$
- $e^{0.25} \approx 1.284025$
- $e^{-0.42} \approx 0.657047$

In Exercises 7–12, write each logarithmic equation as an exponential equation.

- $\ln(1.822119) \approx 0.6$
- $\ln(12.182494) \approx 2.5$

9.  $\ln(23.6) \approx 3.161247$

10.  $\ln(0.697676) \approx -0.36$

11.  $\ln(0.069460) \approx -2.6670$

12.  $\ln 3 \approx 1.098612$

In Exercises 13–22, use the inverse relationship between  $f(x) = e^x$  and  $g(x) = \ln x$  to simplify each expression.

13.  $e^{\ln(4.6)}$

14.  $e^{\ln(0.7)}$

15.  $\ln(e^3)$

16.  $\ln(e^{-0.86})$

17.  $\ln \sqrt[3]{e}$

18.  $\ln \frac{1}{e^2}$

19.  $e^{\ln(5x)}$

20.  $e^{\ln(x+4)}$

21.  $\ln(e^{2t-1})$

22.  $\ln(e^{1-0.2t})$

In Exercises 23–34, use the properties of logarithms to rewrite each expression as the logarithm of a single expression. Be sure to use positive exponents and avoid radicals.

23.  $\ln x + 3 \ln y$

24.  $\frac{1}{2}(\ln x + \ln y)$

25.  $\ln x - \ln y + \ln z$

26.  $\ln x + \ln y - \frac{1}{2} \ln z$

27.  $\ln x + \ln(x+3)$

28.  $\ln(x+4) + \ln(x-1)$

29.  $2 \ln x - \ln(x+1)$

30.  $\ln(x^2+2) - \frac{1}{2} \ln x$

31.  $\ln(x^2-2x+1) - \ln(x-1)$

32.  $3 \ln x + \frac{1}{2} \ln(x+5)$

33.  $\ln(x+3) + \ln(x+1) - \frac{1}{2} \ln x$

34.  $\ln(x^2-3x-4) - \ln(x-4)$

In Exercises 35–46, use the properties of logarithms to rewrite each expression as a sum, difference, or constant multiple of logarithms. Replace all radicals with exponents.

35.  $\ln(x^3y^2)$

36.  $\ln((xy)^{-2})$

37.  $\ln \sqrt[3]{\frac{x}{y}}$

38.  $\ln \sqrt[3]{xy^2}$

39.  $\ln \left( \frac{15x}{\sqrt{y}} \right)$

40.  $\ln \left( \frac{\sqrt{3x}}{y^4} \right)$

41.  $\ln \sqrt{4x+1}$

42.  $\ln(x\sqrt{2x+3})$

43.  $\ln \frac{e}{(x+2)^2}$

44.  $\ln \left( \left( \frac{x-5}{e^x} \right)^2 \right)$

45.  $\ln(x^2-16)$

46.  $\ln(x^2-3x-10)$

In Exercises 47–60, use the properties of logarithms to solve each equation.

47.  $2e^{2x+1} = 26$

48.  $e^{2x+3} = 3.5$

49.  $e^{-0.6t} = 0.8$

50.  $6e^{-0.4t} = 48$

51.  $3 \cdot 5^x = 54$

52.  $4^{2x} = 0.016$

53.  $10^{3x-1} = 8.6$

54.  $10^{1-2x} = 72$

55.  $\ln x + \ln(2x) = \ln 18$

56.  $\ln(x+4) + \ln(x-4) = \ln 9$

57.  $\ln(x+1) + \ln(x-1) = 0$

58.  $\ln(x+5) + \ln(x-5) = 0$

59.  $\ln(x^2 + 4x - 5) - \ln(x+5) = 1$

60.  $\ln(x^2 + 2x - 3) - \ln(x-1) = 2$

 **APPLICATIONS**

**61. Compound interest:** A deposit of \$5000 is made into an account that pays interest at an annual rate of 9.6 percent. Find the time required for the investment to double if the interest is compounded as indicated. Round to the nearest hundredth of a year.

- a. annually                      b. quarterly                      c. monthly

**62. Compound interest:** A deposit of \$2000 is made into an account that pays 8.4 percent annual interest. Find the time required for the account to be worth \$3600 if the interest is compounded as indicated. Round to the nearest hundredth of a year.

- a. annually                      b. quarterly                      c. monthly

**63. Interest compounded continuously:** A deposit of \$5000 is made into an account that pays interest at a rate of 8 percent compounded continuously. Find the time required for the amount to double. Round to the nearest hundredth of a year.

**64. Interest compounded continuously:** Anna deposited \$6000 into an account that pays 7.6 percent annual interest compounded continuously. How long will it take for the balance to reach \$10,000? Round to the nearest hundredth of a year.

**65. Depreciation:** The value  $V$  of a machine  $t$  years after it was purchased is given by  $V = C(1-r)^t$ , where  $C$  is the original cost and  $r$  is the rate of depreciation. A machine is purchased for \$12,000. If  $r = 0.16$ , in how many years will the machine be worth only \$6000? Round to the nearest hundredth of a year.

**66. Depreciation:** The value  $V$  of a machine  $t$  years after it was purchased is given by  $V = C(1-r)^t$ , where  $C$  is the original cost and  $r$  is the rate of depreciation. The owner of a furniture shop purchased a special saw for \$8600. She plans to depreciate the saw at a rate of 12 percent per year. In how many years will the value of the saw be \$2380? Round to the nearest hundredth of a year.

**67. Printing costs:** The total cost in dollars of printing  $x$  thousand copies of a book is given by  $C(x) = 9000 + 40,000 \ln(0.5x + 1)$ .

- a. Find  $C(2)$ ,  $C(8)$ , and  $C(10)$ .  
 b. Find the cost of printing 12,000 copies.  
 c. If the total cost of printing is \$100,000, how many books are printed?

**68. City planning:** To plan for the future needs of the city, the Department of Public Works uses the function  $P(t) = 36,000 + 8400 \ln(0.8t + 1)$  to estimate the population  $t$  years from now.

- a. What is the city's current population?  
 b. Find  $P(2)$ ,  $P(6)$ , and  $P(10)$ .  
 c. In how many years will the population reach 60,000? Round to the nearest hundredth of a year.

By testing values, we find that  $f(x)$  is decreasing on the interval  $(0, e^{-1})$  and increasing on the interval  $(e^{-1}, +\infty)$ .

Taking the second derivative of  $f(x)$ , we find that  $f''(x) = \frac{1}{x} > 0$  for all  $x$  on the interval  $(0, +\infty)$ . Therefore,  $f(x)$  is concave upward on the interval  $(0, +\infty)$ .

A local (and absolute) minimum occurs at the critical value  $x = e^{-1}$ , and

$$\begin{aligned} f(e^{-1}) &= e^{-1} \ln(e^{-1}) \\ &= e^{-1}(-1) = -e^{-1}. \end{aligned}$$

**Note:** One easy point to get without a calculator is  $(1, 0)$  (recall that  $\ln 1 = 0$ ). Therefore, it is possible to notice that  $1 \cdot \ln 1 = 0$ , and  $(1, 0)$  is an  $x$ -intercept.

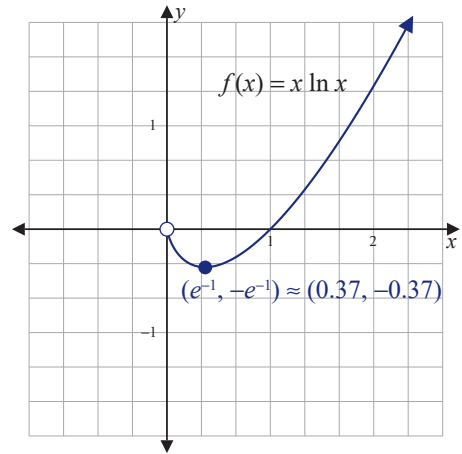

## 5.3 EXERCISES

### 💡 PRACTICE

Find the derivative of each of the functions in Exercises 1–32.

1.  $f(x) = x^2 - \ln x$

2.  $f(x) = 4x^2 + \ln(x^2)$

3.  $f(x) = 25 + x \ln x$

4.  $f(x) = (x^2 + 1) \ln x$

5.  $y = \frac{\ln x}{x}$

6.  $y = \frac{x^2}{\ln x}$

7.  $y = (\ln x)^3$

8.  $y = \sqrt{\ln x}$

9.  $f(x) = \ln(5x + 3)$

10.  $f(x) = \ln(7x - 2)$

11.  $f(x) = \ln(x^2 + 2)$

12.  $f(x) = \ln(x^2 + 3x)$

13.  $f(x) = \ln \sqrt{2x^2 - 1}$

14.  $f(x) = \ln \sqrt{x^3 + 4}$

15.  $y = \ln((4x + 3)^2)$

16.  $f(x) = \ln((x^2 - 4)^3)$

17.  $y = \sqrt{x} \ln(x^2 + 2)$

18.  $y = \frac{\ln(5x + 2)}{x^3}$

19.  $y = \frac{\ln(x^2 + 2x - 1)}{x}$

20.  $y = x^{-2} \ln(x^2 - 3x + 4)$

21.  $y = \log_3(9x)$

22.  $f(x) = \log_2(7x^2 + 9)$

23.  $y = 3x \log x$

24.  $f(x) = \frac{\log_5(x)}{x^2}$

25.  $f(x) = \ln((3x+1)(x^2+3))$

26.  $f(x) = \ln(x^2(4x-1))$

27.  $f(x) = \ln((2x-1)^2(x^2-2))$

28.  $f(x) = \ln(\sqrt{4x-7}(6x+7))$

29.  $y = \ln\left(\frac{x+1}{x-2}\right)$

30.  $y = \ln\left(\frac{3x-1}{x+5}\right)$

31.  $f(x) = \ln\left(\frac{x^2-5}{2x+9}\right)$

32.  $f(x) = \ln\sqrt{\frac{4x+3}{x^2-6}}$

For Exercises 33–38, determine a formula for  $f''(x)$ . Use your calculator (if necessary) to solve the equation  $f''(x) = 0$  and locate any possible inflection points.

33.  $f(x) = \frac{x}{\ln x}$

34.  $f(x) = (2x + x^2) \ln x$

35.  $f(x) = 3x^2 \ln x$

36.  $f(x) = \ln(x^3)$

37.  $f(x) = (\ln x)^3$

38.  $f(x) = \ln x + x^2 + 3x + 2$

Use logarithmic differentiation to find the derivatives of the functions in Exercises 39–46.

39.  $y = (2x-5)^3 \sqrt{x^2-2x}$

40.  $y = (4-5x)^4 (7x+2)^{\frac{2}{3}}$

41.  $y = (x^2+2)^4 (x^2-1)^{-\frac{1}{3}}$

42.  $y = (3x-2)^5 \sqrt{x^2+x}$

43.  $y = \frac{(2x+x^2)^3}{(4x-9)^2}$

44.  $y = \frac{\sqrt[3]{x^2+4}}{(2-5x)^3}$

45.  $y = \frac{(x+2)^2 (3x+4)^2}{\sqrt{x-6}}$

46.  $y = \frac{(x^2-3)^2 \sqrt{x^2+3x}}{x+7}$

In Exercises 47–52, find the absolute extrema for each of the functions on the indicated interval.

47.  $f(x) = x - \ln x; [0.5, 2]$

48.  $f(x) = x^2 - 8 \ln x; [0.3, 4]$

49.  $f(x) = \frac{x}{\ln x}; [1.2, 3]$

50.  $f(x) = \frac{\ln x}{x^2}; [1, 2]$

51.  $f(x) = x^2 - \ln(x^3); [1, e]$

52.  $f(x) = \ln(3+2x-x^2); [0, 2.5]$

Using the curve-sketching techniques discussed in Chapter 4, sketch the graph of each function in Exercises 53–58.

53.  $f(x) = 4x \ln x$

54.  $f(x) = x^2 \ln x$

55.  $f(x) = x - 3 \ln x$

56.  $f(x) = 4x - \ln(x^2)$

57.  $f(x) = \frac{\ln x}{x}$

58.  $f(x) = \frac{\ln x}{x^2}$

### APPLICATIONS

- 59. Marginal revenue:** A retailer has determined that the revenue from the sale of  $x$  end tables is given by the function  $R(x) = 96x + \ln(4x^2 + 15)$  dollars. Find the marginal revenue.
- 60. Advertising:** An automobile dealer has estimated that he can sell  $N(x) = 420 + 72 \ln(1 + 0.5x)$  cars annually, where  $x$  (in thousands of dollars) is the amount spent on advertising.
- Find the number of cars sold if \$6000 is spent on advertising.
  - Find the rate of change in number of cars sold if \$6000 is spent on advertising.
- 61. Revenue:** The daily demand for a product is given by  $p = -8 \ln(0.01x)$ , where  $p$  is the price in dollars when  $x$  units are sold and  $0 < x \leq 100$ . Find the maximum daily revenue.
- 62. Revenue:** The demand for a product is given by  $p = 14 - 6.5 \ln x$ , where  $x$  is the number of units (in thousands) that can be sold at a price  $p$  dollars and  $2 \leq x \leq 8$ . Find the maximum revenue.
- 63. Insect population:** Mediterranean fruit flies are discovered in a citrus orchard. The Department of Agriculture has determined that the population of flies  $t$  hours after the orchard has been sprayed with pesticide is approximated by  $N(t) = 25 - 5t \ln(0.04t) - t$ , where  $0 < t \leq 25$ .
- Find  $N(3)$ ,  $N(10)$ ,  $N(25)$ .
  - What will be the maximum number of flies in the orchard?
- 64. Air quality:** The Air Quality Management Board estimates that  $t$  hours after midnight in a major city the level of ozone in the air is about  $N(t) = 0.013 - 0.007t \ln(0.026t)$  parts per million, where  $0 < t \leq 18$ .
- Find  $N(6)$ ,  $N(10)$ ,  $N(18)$ .
  - Find the maximum level of pollution.

$$\begin{aligned}\frac{dy}{dx} &= (\ln 10) \cdot (10^{-2x}) \cdot \frac{d}{dx}(-2x) \\ &= (\ln 10) \cdot (10^{-2x}) \cdot (-2) \\ &= -2 \ln 10 \cdot (10^{-2x})\end{aligned}$$

## 5.4 EXERCISES

### PRACTICE

Find the first and second derivative of each of the functions in Exercises 1–8.

- |                        |                              |
|------------------------|------------------------------|
| 1. $f(x) = 3e^x$       | 2. $f(x) = -6e^x$            |
| 3. $f(x) = x^2 + 5e^x$ | 4. $f(x) = 4x^2 - 2e^x$      |
| 5. $f(x) = xe^x$       | 6. $f(x) = -7x^2e^x$         |
| 7. $f(x) = 9^x$        | 8. $f(x) = 3 \cdot 5^{2x-1}$ |

For Exercises 9–18, find a formula for  $f'(x)$  and determine the slope  $f'(a)$  at the point where  $x = a$  is given.

- |  |  |
|--|--|
| 9. $f(x) = e^x \ln x$ ; $x = 1$            | 10. $f(x) = e^x \ln(x+4)$ ; $x = 1$      |
| 11. $f(x) = \frac{e^x}{e^x - 1}$ ; $x = 2$ | 12. $f(x) = \frac{e^x}{\ln x}$ ; $x = e$ |
| 13. $f(x) = 2e^{4x}$ ; $x = -1$            | 14. $f(x) = 8e^{-3x}$ ; $x = 4$          |
| 15. $f(x) = 3e^{2x+1}$ ; $x = 0$           | 16. $f(x) = 5e^{\frac{x}{2}}$ ; $x = 0$  |
| 17. $f(x) = 10^{\frac{2}{x}}$ ; $x = 2$    | 18. $f(x) = -x \cdot 3^{-x}$ ; $x = 0$   |

For Exercises 19–22, find a formula for  $f'(x)$  and use it to determine the intervals on which  $f(x)$  is increasing or decreasing.

- |                             |                             |
|-----------------------------|-----------------------------|
| 19. $f(x) = e^{1-x^2}$      | 20. $f(x) = e^{-0.04x^2}$   |
| 21. $f(x) = (e^{2x} - 4)^2$ | 22. $f(x) = (e^{4x} + 2)^3$ |

For Exercises 23 and 24, determine  $f'(x)$  and use it to determine the intervals on which  $f(x)$  is increasing or decreasing. Determine for each function if there is a horizontal asymptote. Confirm your results with a graphing calculator.

- |                                    |  |
|------------------------------------|--|
| 23. $f(x) = \sqrt{e^{-0.2x} + 11}$ | 24. $f(x) = \frac{1}{\sqrt{3e^x + 1}}$ |
|------------------------------------|--|

Find  $f'(x)$  and use it to argue whether or not there is an oblique asymptote for each of the functions in Exercises 25 and 26.

25.  $f(x) = \ln(e^x + 1)$

26.  $f(x) = \ln\sqrt{5 + e^{2x}}$

In Exercises 27–34, find the absolute extrema of the given function on the indicated interval.

27.  $f(x) = xe^{2x}$ ;  $[-2, 1]$

28.  $f(x) = xe^{\frac{x}{3}}$ ;  $[-4, 0]$

29.  $f(x) = x^2e^{-x}$ ;  $[-1, 2]$

30.  $f(x) = 2x^2e^{-x}$ ;  $[-2, 3]$

31.  $f(x) = 5e^{1-x^2}$ ;  $[-2, 1]$

32.  $f(x) = 3xe^{-x^2}$ ;  $[-2, 2]$

33.  $f(x) = (2x + 3)e^{-0.2x}$ ;  $[1, 4]$

34.  $f(x) = (4x - 1)e^{-0.5x}$ ;  $[0, 3]$

For each of the functions in Exercises 35–40, **a.** find any critical values, **b.** find any hypercritical values, **c.** find all intervals of concavity, and **d.** sketch the graph of the function. If available, confirm your results with a graphing calculator.

35.  $f(x) = xe^{-0.4x}$

36.  $f(x) = 2xe^{-0.5x}$

37.  $f(x) = 4x^2e^{-x}$

38.  $f(x) = 3x^2e^{-x}$

39.  $f(x) = e^x + e^{-x}$

40.  $f(x) = \frac{e^x}{x}$

### APPLICATIONS

- 41. Revenue:** The demand for a product is given by  $D(x) = 140e^{-0.05x}$ , where  $x$  is the number of units sold each week and  $0 \leq x \leq 30$ .
- Find the number of units sold that will yield maximum revenue.
  - Find the price per unit that will yield maximum revenue.
- 42. Revenue:** The demand equation for a certain product is given by  $D(x) = 210e^{-0.025x}$ , where  $x$  is the number of units sold each week and  $0 \leq x \leq 60$ .
- Find the number of units sold that will yield the maximum revenue.
  - Find the price per unit that will yield maximum revenue.
- 43. Advertising:** An automobile manufacturer is planning a television advertisement campaign to introduce a new model for their truck. It is estimated that  $N(t) = 600(1 - e^{-0.02t})$  people (in thousands) will have seen the advertisement after  $t$  days of advertising. How fast is  $N$  increasing at the end of 7 days?
- 44. Insect population:** The mosquito population of a pool of water is estimated to be  $P(t) = 400 + 1400e^{-0.3t}$ , where  $t$  is the number of hours after the pool has been treated. Find the rate of change in the population at the end of 5 hours.
- 45. Bacterial population:** The population of bacteria in an experimental culture is estimated by  $N(t) = \frac{10,000}{1 + 9e^{-0.14t}}$ , where  $t$  is the number of hours after the experiment begins. How fast is the population changing at the end of 5 hours?

- 46. Disease control:** The elk herd in a national park has been infected by a contagious disease. The number of infected animals is estimated by  $N(t) = \frac{600}{1 + 49e^{-0.36t}}$ , where  $t$  is the number of days after the disease was discovered. How fast is the disease spreading after 4 days?
- 47.** Suppose the value of the inventory of original Winchester rifles at Bill's Antique Firearms Company has increased according to the formula  $r(t) = \frac{8500}{1 + 10e^{-0.6t}}$ , where  $r$  is the average value (in dollars) of one of their rifles and  $t$  is the number of years since 2000.
- What was the average value of a rifle in 2000? In 2005?
  - At what rate was  $r$  changing in 2005? In 2006?
  - If there is an inflection point for  $r(t)$ , locate it and explain its significance in the application.
  - When is the rate of increase of  $r$  at a maximum?
- 48.** Suppose an advertising campaign for the sale of a new magazine, *Dungeons and Creeps*, causes sales to vary according to the formula  $S(t) = 8(1 - 0.3e^{-0.2t+1})$ , where  $S$  is monthly sales in thousands of magazines and  $t$  is time in months since the ad campaign started.
- What were the monthly sales when the ad campaign started?
  - What was the rate at which sales were changing after 4 months into the campaign?
  - What are the long-term monthly sales expectations?
- 49.** A research scientist determines that a mass of algae in a pond grows according to  $A(t) = 1 + 2te^{-0.5t}$ , where  $A$  represents the mass-density of algae in the pond in suitable units and  $t$  is the time in months ( $t = 0$  corresponds to April 1<sup>st</sup>).
- What day of the year corresponds to a maximum  $A$ -value?
  - When does the rate of decline in algae reach its maximum?
- 50.** A certain calculus student recalls information according to the formula  $p = 70e^{-0.6x} + 30$ , where  $p$  is the percentage of information retained after  $x$  weeks.
- After 4 weeks, what percentage of a lesson is retained?
  - After 4 weeks, at what rate is the percentage changing?
  - What does the model predict a few months after the calculus course is over?
- 51.** Inexpensive videos detailing the championship basketball season of Castle High School are sold locally by a civic club to raise money for next year's team. The total sales are given by  $S = \frac{12,500}{1 + 15e^{-0.5x}}$ , where  $S$  is the total number of videos sold after  $x$  weeks.
- What are the total sales after 3 weeks?
  - What is the rate of change of sales after 3 weeks?
  - After about how many weeks will the total sales begin to level off?
  - When is the sales rate increasing fastest? Illustrate this point graphically.

 **WRITING & THINKING**

52. a. Find the equation of the tangent line to  $f(x) = 2e^{-x^2+1} + 4$  at the point where  $x = 2$ .  
 b. Discuss the advantages and disadvantages of using the tangent line to get values of  $f(x)$  for  $x \geq 2$  rather than the function itself.
53. Determine  $k$  in the equations that follow by finding  $f'(0)$ . Use logarithmic differentiation.  
 a. Let  $f(x) = 10^x$ . Determine the value of  $k$  in the formula  $f'(x) = k \cdot 10^x$ .  
 b. Let  $y = f(x) = \pi^x$ . Determine  $k$  in the formula  $f'(x) = ky$ .
54. In a psychological experiment, Calculus I students repeatedly took a test that asked them to find the derivatives of ten functions. The students' responses are modeled by  $R(t) = 100(1 - 2^{-t})$ , where  $t$  is the number of times the test has been given and  $R$  is the percentage of students scoring 90% or better on the test. Here,  $0 \leq t \leq 6$  and  $0 \leq R \leq 100$ .  
 a. Use a graphing calculator to sketch the graph of  $R(t)$ .  
 b. Interpret  $R(2) = 75$ .  
 c. Interpret  $R'(2) = 17.3$ .  
 d. Why is  $R(3) \neq 75 + 17.3$ ?

 **TECHNOLOGY**

Use a graphing calculator to graph  $f(x)$  and  $f'(x)$ . Then locate all extrema and all inflection points, if any.

55.  $f(x) = e^{-x^2} \ln(x^2 + 2)$

56.  $f(x) = \ln \frac{2 + 3e^{-x}}{x + 2}$

Thus, initially, there are 200 grams of the isotope present. We want to find the time it takes for there to be 100 grams left (half of the initial amount of 200 grams).

Therefore, we want to find  $t$  in the equation

$$100 = 200e^{-0.05t}.$$

We divide both sides of the equation by 200 and then use the definition of natural logarithm:

$$\begin{aligned}\frac{100}{200} &= \frac{200e^{-0.05t}}{200} \\ \frac{1}{2} &= e^{-0.05t} \\ -0.05t &= \ln \frac{1}{2}.\end{aligned}$$

Thus,

$$t = \frac{\ln \frac{1}{2}}{-0.05} \approx 13.86.$$

The half-life of the isotope is about 13.86 years.

## 5.5 EXERCISES

### APPLICATIONS

- Population:** The population of a city is growing exponentially at a rate of 3.5 percent per year. The population was 8400 in 2000.
  - Find an exponential function that represents the population  $t$  years after 2000.
  - What was the population in the year 2010?
  - When was the population 12,800?
- Bee population:** A swarm of bees grows exponentially at a rate of 4 percent hourly. Initially, there were 900 bees in the swarm.
  - Find an exponential function for the number of bees in the swarm after  $t$  hours.
  - How many bees are in the swarm after 6 hours?
  - How many hours will it take for the swarm to double in size? Round your answer to the nearest tenth.
- Cost:** In 2018, the cost of a medium pizza was about \$9.00. In 2021, the cost was \$12.00. If the cost is growing exponentially, predict the cost of a medium pizza in 2027?
- Ant colony:** A colony of ants is growing exponentially. When first observed, the colony contained about 400 ants. If at the end of 9 days there are about 700 ants, approximately how many ants will be present at the end of 15 days?
- Cell growth:** A cell culture grows from 1000 to 1600 cells in 12 hours. If the rate of growth is proportional to the size, when will the culture contain 2000 cells?

6. **Bacterial population:** A bacteria culture grows at a rate proportional to its size. If the population doubles every 6 hours, how long will it take for the population to be three times its initial size?
7. **Demand for oil:** The demand for oil in the United States doubles every 8 years. How long will it take for the demand to triple?
8. **Inflation:** The amount of goods and services that costs \$100 on January 1, 2015 costs \$139.10 on January 1, 2018. Estimate the cost of the same goods and services on January 1, 2025. Assume the cost is growing exponentially.
9. **Interest compounded continuously:** One thousand dollars is deposited in a savings account where the interest is compounded continuously. After 4 years, the balance will be \$1366.15. When will the balance be \$1870.00?
10. **Half-life:** The decay rate for a radioactive isotope is 2.6 percent per year. Find its half-life.
11. **Half-life:** The decay rate of a radioactive isotope is 6.5 percent per year. Find its half-life.
12. **Half-life:** The half-life of a radioactive material is 1480 years. After how many years will only 20 percent of the material remain?
13. **Archaeological dating:** A wooden carving found at an archaeological dig contains about 34 percent of its carbon-14. Approximately how old is the carving?
14. **Archaeological dating:** Bones from the skeleton of an animal have lost 62 percent of their carbon-14. Estimate the age of the bones.
15. **Atmospheric pressure:** As the elevation above sea level is increased, the atmospheric pressure declines exponentially. The pressure at sea level is approximately 15 lb/in.<sup>2</sup> and the pressure at 3000 feet of elevation is about 13 lb/in.<sup>2</sup> Find the pressure at 5000 ft.
16. **Drug concentration:** The concentration of a drug in the body fluids is known to decline exponentially. If 20 mg of a drug is administered and 8 mg remains after 3 hours, how much will remain after 5 hours?
17. **Depreciation:** It is determined that the value of a piece of machinery declines exponentially. A machine that was purchased 5 years ago for \$65,000 is worth \$35,000 today. What will be the value of the machine 5 years from now?
18. **Population:** The population of a certain economically depressed union is declining exponentially at a rate of 1.5 percent. If the population in 2010 was 30,000, estimate the population in 2030.
19. **Reliability:** Studies show that the fraction  $P$  of light bulbs that have burned out after  $t$  hours of use is given by  $P = 1 - e^{-0.03t}$ . What fraction of the bulbs have burned out after 50 hours? How long will it be before half of the bulbs have burned out?

- 20. Advertising:** A radio station estimates that during an intense advertising campaign, the number of people  $N$  who will hear a commercial is given by  $N = A(1 - e^{-0.02x})$ , where  $A$  is the number of people in the broadcasting area and  $x$  is the number of times the commercial is run. There are 60,000 people in the area.
- How many people will hear the commercial if it is run 20 times?
  - How many times should the station plan to run the commercial to be certain that at least 30,000 people hear it?
- 21. Ecology:** The Department of Fisheries has begun a reclamation project at a lake where the fish population was nearly destroyed by agricultural chemicals. They estimate that the population of fish in  $t$  years will be  $P = 6000 - 5200e^{-0.28t}$ .
- What was the initial population?
  - What will be the population after 4 years?
  - How long will it take for the population to be 5000 fish?
- 22. Advertising:** The manager of The Sound Lab has determined that after an intense advertising campaign, the monthly sales of a particular wireless speaker can be approximated by  $N = 300 + 180e^{-0.04t}$  units, where  $t$  is the number of months after the campaign.
- Find the monthly sales initially.
  - Find the monthly sales when  $t = 6$ .
  - When will the monthly sales be 400 units?
- 23. Skills development:** Beverly is making a small souvenir to give to each person attending her family reunion. The length of time, in minutes, she takes to make the  $n^{\text{th}}$  one is given by the function  $T(n) = 12 + 30e^{-0.1n}$ . How long will it take her to make the 30<sup>th</sup> souvenir?
- 24. Dairy farming:** The number of dairy farmers in a particular state who are feeding a new supplement to their milking cows is given by the function  $W(t) = 340(1 - e^{-0.09t})$ , where  $t$  is the number of months the supplement has been available. How long will it be before 200 farmers are feeding the supplement to their cows?
- 25. Cost:** The total cost function for a local company is given by  $C(t) = 12 - ce^{-kt}$  in thousands of dollars, where  $t$  is the time in months. The fixed costs are \$5000 and the total cost after 2 months is \$10,200. Find the total cost at the end of 6 months.
- 26. Skills development:** The time that it takes a service attendant to change a tire is given by the function  $T(x) = 4.4 + Ce^{-kx}$  minutes, where  $x$  is the number of tires the attendant has changed before. It takes Patrick 15 minutes to change the first tire ( $x = 0$ ) and 9.3 minutes to change the seventh tire. How long will it take him to change the eleventh tire?

## Solution

- a. The quantity demanded is  $x$  and  $x = F(p)$ .

$$\begin{aligned}x &= F(1.70) \\ &= 180 - 30(1.70) \\ &= 129\end{aligned}$$

$$\text{b. } E = -\frac{pF'(p)}{F(p)} = -\frac{p(-30)}{180 - 30p} = \frac{p}{6 - p}$$

$$\text{c. } E(1.70) = \frac{30(1.70)}{180 - 30(1.70)} = \frac{51}{129} = \frac{17}{43}$$

- d. Since  $E < 1$ , the demand is inelastic and so an increase in price will bring a decrease in demand and an increase in revenue.

$$\begin{aligned}\text{e. } R &= xp = (180 - 30p)p \\ &= 180p - 30p^2\end{aligned}$$

Thus,  $R' = 180 - 60p$ . Setting  $R' = 0$ , we obtain  $60p = 180$ , so  $p = \$3.00$  per loaf.

Since  $R'' = -60$ , the function  $R$  is concave down at  $p = 3$  and this price gives a maximum for the revenue.

## 5.6 EXERCISES

 PRACTICE

For each of the demand functions in Exercises 1–16, find **a.** the function describing the elasticity of demand and **b.** the value of  $x$  that maximizes the revenue.

- |                                       |  |
|---------------------------------------|--|
| 1. $p = D(x) = 84 - 3x$               | 2. $p = D(x) = 144 - 1.5x$               |
| 3. $p = D(x) = 520 - 2.6x$            | 4. $p = D(x) = 480 - 3.2x$               |
| 5. $p = D(x) = 200e^{-0.2x}$          | 6. $p = D(x) = 67e^{-0.1x}$              |
| 7. $p = D(x) = 88e^{-0.025x}$         | 8. $p = D(x) = 130e^{-0.04x}$            |
| 9. $p = D(x) = \sqrt{150 - x}$        | 10. $p = D(x) = \sqrt{180 - 2x}$         |
| 11. $p = D(x) = \sqrt{162 - 3x}$      | 12. $p = D(x) = \sqrt{255 - 2.5x}$       |
| 13. $p = D(x) = 18 - \sqrt{x}$        | 14. $p = D(x) = 21 - 2\sqrt{x}$          |
| 15. $p = D(x) = 363 - x^2, x \leq 18$ | 16. $p = D(x) = 600 - 0.5x^2, x \leq 34$ |

 APPLICATIONS

- 17. Maximum revenue:** The demand function for an electric pencil sharpener is given by  $p = D(x) = 19.2 - 0.4x$  dollars. Find the level of production for which the revenue is maximized.
- 18. Maximum revenue:** The demand function for a popular stereo receiver is given by  $p = D(x) = 540 - 0.05x^2$  dollars. Find the level of production for which the revenue is maximized.
- 19. Elastic demand:** The demand function for an exclusive wool blanket is given by  $p = D(x) = 33 - 2\sqrt{x}$  dollars, where  $x$  is in thousands of blankets. Find the level of production for which the demand is elastic.
- 20. Elastic demand:** Find the levels of production for which the demand is elastic if the demand is given by  $p = D(x) = \sqrt{207 - 3x}$  dollars.
- 21. Elastic demand:** An arcade sells video games and determines that  $x = 30\left(1 - e^{-\frac{p}{10}}\right)$ , where  $x$  is the number of video games demanded for a unit price  $p$ .
- Determine the quantity demanded when  $p = \$10$  per game.
  - Determine  $E$  and interpret the result at  $p = \$10$ .
  - What revenue is generated at  $p = \$10$ ?
- 22. Elastic demand:** Lucky Blooms sells a new rose variety that has established a demand of  $x = f(p) = \frac{e^{\frac{p}{3}} + 350}{e^{\frac{p}{2}}}$ .
- Determine the quantity demanded when  $p = \$3$ .
  - Determine  $E$  and interpret the result at  $p = \$3$ .
- 23. Elastic demand:** The demand for a product is given by  $x = F(p) = \frac{1800}{10 + \ln(1 + p)}$ .
- If  $p = 20$ , determine  $E$  and interpret the results.
  - What is the revenue function  $R$ ?
  - Use  $R'$  to determine if  $R$  is increasing at  $p = 20$ . Is your answer consistent with part a.?
- 24. Elastic demand:** Suppose a product has a demand function  $x = F(p) = 300e^{-\frac{p}{10}}$ .
- Find the elasticity function.
  - Is the demand elastic or inelastic at  $p = \$20$ ?
  - Determine the unit price which maximizes revenue.
  - Discuss whether or not your answers to b. and c. are consistent.
- 25. Elastic demand:** Suppose the demand for a product is  $p = D(x) = 300e^{-\frac{x^2}{200}}$ .
- Determine the unit price if the quantity  $x = 5$ .
  - What is formula for  $D'(x)$ ?
  - What is the elasticity at  $x = 5$ ?
  - Determine the value of  $x$  which maximizes revenue.

speed at  $t = 0$ . Thus  $C_1 = -200$  m/s. We use  $-200$  rather than  $+200$  since the direction of the meteor is toward the origin (so  $s$  is decreasing due to the speed). Therefore,

$$v(t) = -30t^2 + 64t - 200.$$

Since  $v = \frac{ds}{dt}$ , we can say  $ds = v \cdot dt$ . Integrating again, we have

$$\int ds = \int v \cdot dt = \int (-30t^2 + 64t - 200) \cdot dt.$$

Integrating a second time gives

$$\begin{aligned} s &= -30\left(\frac{1}{3}t^3\right) + 64\left(\frac{1}{2}t^2\right) - 200t + C_2 \\ s &= -10t^3 + 32t^2 - 200t + C_2. \end{aligned}$$

Once again there is a constant of integration to evaluate. If at the time of initial measurement the distance of the meteor from Earth is 50,000 kilometers, then  $s(0) = 50,000,000$  meters.

$$50,000,000 = s(0) = -10(0)^3 + 32(0)^2 - 200(0) + C_2 = C_2$$

Here we see  $C_2 = 50,000,000$  meters, the initial distance of the meteor from Earth.

It is typical of “acceleration” problems that there are two integrations, two constants of integration to evaluate, and two additional pieces of data necessary for this evaluation. It is common to use the notation  $v_0$  and  $s_0$  to denote initial ( $t = 0$ ) values of velocity and distance.

One case of special interest is a body falling due to Earth’s gravity. In this case, the acceleration  $a$  is a constant. As before,  $a = \frac{dv}{dt}$  so  $dv = a \cdot dt$ . Integrating both sides gives

$$v = at + C.$$

The constant  $C$  is  $v_0$ , the initial velocity. That is,  $v = at + v_0$ . Since  $\frac{ds}{dt} = v$ ,  $ds = v \cdot dt$ . One more integration gives

$$\begin{aligned} s &= \int ds = \int (at + v_0) dt = a\left(\frac{1}{2}t^2\right) + v_0t + s_0 \\ s &= \frac{1}{2}at^2 + v_0t + s_0. \end{aligned}$$

## 6.1 EXERCISES

### PRACTICE

In Exercises 1–12, show that the function  $F(x)$  is an antiderivative of the function  $f(x)$  by differentiating  $F$ .

- $F(x) = 4x - 1$ ,  $f(x) = 4$
- $F(x) = 6x$ ,  $f(x) = 6$
- $F(x) = 3x^2 + 5x + 2$ ,  $f(x) = 6x + 5$

$$4. F(x) = \frac{1}{2}x^2 - 4x + e^{2x} - 1, \quad f(x) = x - 4 + 2e^{2x}$$

$$5. F(x) = \ln x - \frac{1}{x} - 4e^{x^2}, \quad f(x) = \frac{1}{x} + \frac{1}{x^2} - 8xe^{x^2}$$

$$6. F(x) = \ln x^3 + \frac{1}{x^2} + 6, \quad f(x) = \frac{3}{x} - \frac{2}{x^3}$$

$$7. F(x) = (x^2 + 3)^4 - 1, \quad f(x) = 8x(x^2 + 3)^3$$

$$8. F(x) = 3(5x - 1)^{\frac{2}{3}} + 8, \quad f(x) = \frac{10}{\sqrt[3]{5x - 1}}$$

$$9. F(x) = \frac{5}{3}(e^x - 4)^3 + e, \quad f(x) = 5e^x(e^x - 4)^2$$

$$10. F(x) = 3e^{x^2-1} - 7, \quad f(x) = 6xe^{x^2-1}$$

$$11. F(x) = \ln(x^2 + 5x - 3) - \sqrt{5}, \quad f(x) = \frac{2x + 5}{x^2 + 5x - 3}$$

$$12. F(x) = \ln(e^{3x} - x) + \sqrt{11}, \quad f(x) = \frac{3e^{3x} - 1}{e^{3x} - x}$$

Find the indefinite integrals in Exercises 13–32.

$$13. \int 7 dx$$

$$14. \int \frac{2}{3} dx$$

$$15. \int 5x^4 dx$$

$$16. \int -2x^{-3} dx$$

$$17. \int (x^2 - 3) dx$$

$$18. \int (x^4 + 5) dx$$

$$19. \int \left( \frac{1}{3} - e^t \right) dt$$

$$20. \int (e^t + t) dt$$

$$21. \int \left( \frac{1}{y} + y^3 \right) dy$$

$$22. \int \left( \frac{1}{\sqrt{y}} - \frac{1}{y} \right) dy$$

$$23. \int \left( 4x^2 + \frac{2}{x} + \frac{1}{x^2} \right) dx$$

$$24. \int \left( 9x - \frac{3}{x} - \frac{1}{\sqrt{x}} \right) dx$$

$$25. \int (2\sqrt[3]{x} + 5\sqrt{x}) dx$$

$$26. \int \left( \sqrt{x} + 6e^x - \frac{5}{x} \right) dx$$

$$27. \int \left( 4e^y - 2y^5 - \frac{1}{5} \right) dy$$

$$28. \int \left( y^{\frac{3}{2}} + 5y^{-\frac{2}{3}} - y^{-1} \right) dy$$

$$29. \int \left( \frac{2}{\sqrt[3]{t}} + \frac{7}{t^3} \right) dt$$

$$30. \int \left( 2t^{\frac{5}{2}} + \frac{4}{t} - \sqrt{3} \right) dt$$

$$31. \int \left( \frac{2}{3}e^x + x^{-\frac{3}{2}} - 7x^{-1} \right) dx$$

$$32. \int \left( 0.25e^x + 4x^{-\frac{1}{4}} \right) dx$$

In Exercises 33–38, perform the indicated multiplication and then integrate.

33.  $\int x^3(2x-1)dx$

34.  $\int x^2(3x-5)dx$

35.  $\int (3t+2)^2 dt$

36.  $\int (5x+6)^2 dx$

37.  $\int \sqrt{y}(y^2+2y-1)dy$

38.  $\int \sqrt{y}(4-3y-2y^2)dy$

In Exercises 39–44, simplify the indicated quotient and then integrate.

39.  $\int \frac{3x^2+5x-4}{x^2} dx$

40.  $\int \frac{x^3-6x^2+x}{x^2} dx$

41.  $\int \frac{4+\sqrt{x}-3x}{x} dx$

42.  $\int \frac{5x^2-2x+3}{\sqrt{x}} dx$

43.  $\int \frac{x^{\frac{3}{2}}+6-2xe^x}{x} dx$

44.  $\int \frac{4x^2+4\sqrt{x}-7x}{x^2} dx$

45. Find the antiderivative  $F(x)$  that satisfies the given condition.

a.  $F'(x) = x^2 - e^x$ ,  $F(0) = 1$

b.  $F'(x) = 6x^2 + x - 10$ ,  $F(0) = 0$

c.  $\frac{dF}{dx} = \frac{10}{\sqrt{x}}$ ,  $F(1) = 20$

d.  $\frac{dF}{dx} = 6e^x - 2$ ,  $F(0) = -10$

46. Given that  $f'(x) = x^2 - 2$ , determine the function  $f(x)$  with the given constant of integration  $C$ . Draw all three functions on the same coordinate system.

a.  $C = -1$

b.  $C = 1$

c.  $C = 3$

47. Given  $f'(x) = 6x^2 - 24x$ .

a. Determine the  $x$ -values at which  $f(x)$  has a local maximum or minimum.

b. Determine whether there is an inflection point.

c. Given  $f(1) = -9$ , sketch  $f$  and determine if the answers to part a. are correct.

## APPLICATIONS

48. **Cost:** The weekly marginal cost of producing  $x$  ice cream makers is  $28 + 0.05x$  dollars per ice cream maker. Find the cost function if the fixed costs are \$2400.

49. **Cost:** The marginal cost of producing  $x$  clock radios is  $0.3x^2 - 0.8x + 24$  dollars per clock radio. The fixed costs are \$1500. Find the cost function.

50. **Revenue:** The marginal revenue from selling  $x$  irons is  $94 - 0.06x$  dollars per iron. Find the revenue function. (**Hint:**  $R(0) = 0$ .)

51. **Revenue:** The marginal revenue from selling  $x$  floor lamps is  $100 - 0.2x$  dollars per lamp. Find the revenue function. (**Hint:**  $R(0) = 0$ .)

- 52. Profit:** The marginal profit from the production and sale of  $x$  cameras is estimated to be  $24 - 0.4x$  dollars per unit.
- Find the firm's profit function if the profit from the production and sale of 80 units is \$240.
  - What is the profit from the sale of 90 units?
- 53. Profit:** A manufacturer has determined that the marginal profit from the production and sale of  $x$  wireless speakers is approximately  $120 - 3x$  dollars per speaker.
- Find the profit function if the profit from the production and sale of 30 speakers is \$1200.
  - What is the profit from the sale of 40 speakers?
- 54. Population:** The population of a community is growing at a rate given by  $\frac{dP}{dt} = 120 - 15t^{\frac{1}{2}}$  people per year. Find a function to describe the population  $t$  years from now if the present population is 8600 people.
- 55. Rodent control:** Animal control officers have implemented a program to eliminate rats in a community. They estimate that the population of rats is changing at a rate of  $\frac{dP}{dt} = 24t^{\frac{1}{2}} - 40t$  rats per month. Find a function for the rat population  $t$  months from now if the current population is estimated to be 6300 rats.
- 56. Air quality:** The air quality control office estimates that for a population of  $x$  thousand people, the level of pollution in the air is increasing at a rate of  $\frac{dL}{dx} = 0.2 + 0.002x$  parts per million per thousand people. Find a function to estimate the level of the pollutants if the level is 5.4 parts per million when the population is 20,000 people.
- 57. Ecology:** Biologists are treating a stream contaminated with bacteria. The level of contamination is changing at a rate of  $\frac{dN}{dt} = -\frac{960}{t^2} - 240$  bacteria per cubic centimeter per day, where  $t$  is the number of days since the treatment began. Find a function  $N(t)$  to estimate the level of contamination if the level after 1 day was about 5720 bacteria per cubic centimeter.
- 58. Height:** An object is projected vertically so that the velocity after  $t$  seconds is given by  $v(t) = 96 - 32t$  feet per second.
- Find the height function  $s(t)$  if  $s(0) = 18$  feet.
  - What will be the height after 3 seconds?
- 59. Distance:** A vehicle travels in a straight line for  $t$  minutes with a velocity  $v(t) = 72t - 6t^2$  feet per minute, for  $0 \leq t \leq 10$ .
- Find the distance function  $s(t)$  if  $s(0) = 0$ .
  - How far will the vehicle travel in 5 minutes?
  - How far will the vehicle travel in 10 minutes?

- 60. Distance:** A particle moves along an axis with velocity given by  $v(t) = 3t - 1$ , where  $t$  is in seconds and  $v$  is in ft/s.
- Determine the acceleration,  $a(t)$ .
  - What is the distance function,  $s(t)$ , if  $s(0) = 5$ ?
- 61. Distance:** A meteor falls partly under the influence of Earth's gravity at a velocity given by  $v(t) = 200 + 30t + 24t^{\frac{1}{2}}$  for  $0 \leq t \leq 24$ , where  $t$  is in hours and  $v$  is in miles per hour.
- Determine the acceleration.
  - Determine the distance function if  $s(0) = 5000$  miles.

**WRITING & THINKING**

- 62. a.** Compute the derivative of  $y = e^{mx+b}$  where  $m$  and  $b$  are constants. Use your answer to determine an integration formula for  $\int e^{mx+b} dx$ .
- b.** Compute the derivative of  $y = \frac{1}{e^{mx+b}}$  where  $m$  and  $b$  are constants. Use your answer to determine an integration formula for  $\int \frac{1}{e^{mx+b}} dx$ .

## 6.2 EXERCISES

 PRACTICE

In Exercises 1–36, use the technique of substitution to perform each integration.

1.  $\int (x+4)^7 dx$

2.  $\int (y-6)^{-3} dy$

3.  $\int 2x(x^2-1)^{\frac{1}{2}} dx$

4.  $\int 3x^2(x^3-5)^{\frac{1}{3}} dx$

5.  $\int \frac{1}{t+2} dt$

6.  $\int \frac{1}{x-11} dx$

7.  $\int \frac{3t^2}{t^3+4} dt$

8.  $\int \frac{1}{y^2-8} \cdot 2y dy$

9.  $\int e^{y+5} dy$

10.  $\int e^{x-9} dx$

11.  $\int e^{-0.2x} (-0.2) dx$

12.  $\int e^{0.5t} (0.5) dt$

13.  $\int \frac{1}{5x+3} dx$

14.  $\int (3y-2)^{-2} dy$

15.  $\int \frac{1}{\sqrt{4x-1}} dx$

16.  $\int e^{-4x} dx$

17.  $\int xe^{2x^2} dx$

18.  $\int \frac{x}{2x^2+5} dx$

19.  $\int \frac{x}{(3x^2-1)^2} dx$

20.  $\int y^2 e^{-2y^3} dy$

21.  $\int \frac{2t+1}{t^2+t-4} dt$

22.  $\int (x^2+3x-1)^4 (2x+3) dx$

23.  $\int 5ye^{-y^2} dy$

24.  $\int \frac{e^{\sqrt{t}}}{\sqrt{t}} dt$

25.  $\int 6x\sqrt{5+2x^2} dx$

26.  $\int \frac{e^t}{e^t-1} dt$

27.  $\int \frac{4}{x^2} e^{\frac{1}{x}} dx$

28.  $\int 4y^3 \sqrt{3y^2+7} dy$

29.  $\int e^{2x} (1-3e^{2x})^2 dx$

30.  $\int \frac{4x+10}{x^2+5x+2} dx$

31.  $\int \frac{\ln x}{x} dx$

32.  $\int \frac{\ln 4x}{x} dx$

33.  $\int \frac{1}{x \ln x} dx$

34.  $\int \frac{(\ln x)^2}{x} dx$

35.  $\int \frac{e^x - e^{-x}}{e^x + e^{-x}} dx$

36.  $\int \frac{7x}{e^{x^2}} dx$

In Exercises 37–40, divide first and then integrate.

37. a.  $\int \frac{x-1}{x-2} dx$       **(Hint:**  $\frac{x-1}{x-2} = 1 + \frac{1}{x-2}$  **)**

b.  $\int \frac{x+3}{x+1} dx$       **(Hint:**  $\frac{x+3}{x+1} = 1 + \frac{2}{x+1}$  **)**

38. a. Rework Exercise 37a and substitute  $u = x - 2$ .b. Rework Exercise 37b and substitute  $u = x + 1$ .

39.  $\int \frac{x+2}{x+4} dx$

40.  $\int \frac{x+5}{x-3} dx$

In Exercises 41–44, find a function  $f(x)$  given  $f'(x)$  and one  $(x, y)$ -value.

41.  $f'(x) = 10xe^{5x^2}$ ;  $(0, 11)$

42.  $f'(x) = \frac{3}{x-5}$ ;  $(6, 5)$

43.  $f'(x) = (2x+2)^5$ ;  $(-1, 10)$

44.  $f'(x) = \frac{12x^2}{(x^3+6)^2}$ ;  $\left(0, -\frac{2}{3}\right)$

### APPLICATIONS

45. **Appreciation:** The value  $V$  of a painting is increasing at a rate of  $4500(25 - 1.8t)^{-\frac{3}{2}}$  dollars per year. The painting originally sold for \$1000.

- Write a function for its value  $t$  years after the original sale.
- What will the painting be worth 5 years after the original sale?

46. **Skills development:** It is estimated that after  $t$  weeks of practice, students in a typing class can increase their speed  $24e^{-0.2t}$  words per minute for each additional week of practice.

- If their initial speed was 0 words per minute ( $S(0) = 0$ ), write a function to represent their speed after  $t$  weeks of practice.
- How fast can they type after 10 weeks (to the nearest word)?

47. **Price:** After the NBA championship basketball game, the price of a souvenir cap changes at the rate of  $-\frac{1}{2x}$  dollars per cap, where  $x$  is the number of caps sold (in thousands). Write a function for the price  $p$  if  $p(10) = 12.85$ .

48. **Profit:** The marginal profit from the production and sale of  $x$  units of a product is estimated to be  $\frac{100}{1+0.5x} - 4.5$  dollars per unit. If  $P(0) = -60$ , find the profit function  $P(x)$ .

- 49. Daily production:** Records show that  $t$  hours after starting work on a typical day, an employee can assemble bikes at a rate of  $\frac{6t+15}{\sqrt{t^2+5t}}$  per hour. Find the daily production function  $N(t)$  if  $N(0) = 0$ .
- 50. Position of a particle:** A particle is moving in a straight line with the velocity  $v(t) = \sqrt{2t+7}$  feet per second, where  $t$  represents time in seconds. Find the position function  $s(t)$  if  $s(0) = 0$ .
- 51. Position of a projectile:** The velocity of a projectile moving in a straight line  $t$  seconds after it is fired is given by  $v(t) = 36 + \frac{60}{(t+1)^2}$  feet per second. Find the position function  $s(t)$  if  $s(1) = 10$ .
- 52.** The marginal value for a tract of land is  $V' = \frac{20}{2t+1}$ , where  $t$  is time in years since 2000 and  $V$  is in thousands of dollars.  
**a.** Determine the function  $V$  in terms of  $t$  if  $V(0) = 20$ .  
**b.** What was the value of the land in 2015?
- 53.** A point mass moving on a horizontal axis has a deceleration given by  $a(t) = -48(2t+1)^2$ , where  $t$  is time in seconds and  $a$  is in feet per second per second.  
**a.** If  $v(0) = 6$  ft/s, determine a velocity function  $v(t)$ .  
**b.** If  $s(0) = -\frac{3}{4}$  feet, determine a distance function  $s(t)$ .
- 54.** The number of viewers of a new TV show grew at a rate  $V'(t) = 900e^{0.3t-4}$  all summer long, where  $V$  is the total number of viewers in thousands and  $t$  is the number of weeks since June 1<sup>st</sup>.  
**a.** Determine  $V(t)$  if  $V(0) = 100$ .  
**b.** At what rate is  $V$  changing when  $t = 5$ ?  
**c.** When will the show hit 1,000,000 viewers ( $V = 1000$ )?
- 55.** Suppose in a medieval country, from 1200 to 1300, the life expectancy of a female serf changed at the rate  $f'(t) = \frac{0.3}{1+0.01t}$ , where  $t$  is time in years after 1200 and  $f(t)$  is the average age of death.  
**a.** What are the units of  $f'(t)$ ?  
**b.** Determine  $f(t)$  if  $f(0) = 30$ .  
**c.** What was the life expectancy of a female serf in 1300?
- 56.** A new evening school is growing at the rate of  $p'(t) = \frac{150}{\sqrt{1+0.2t}}$ , where  $p(t)$  is the total evening school student population and  $t$  is the time in years after 2000. The initial enrollment was 1500 students.  
**a.** How fast was enrollment changing in 2002?  
**b.** What was the expected enrollment in 2005?

## 6.3 EXERCISES

 PRACTICE

In Exercises 1–2, find the area of the shaded region.

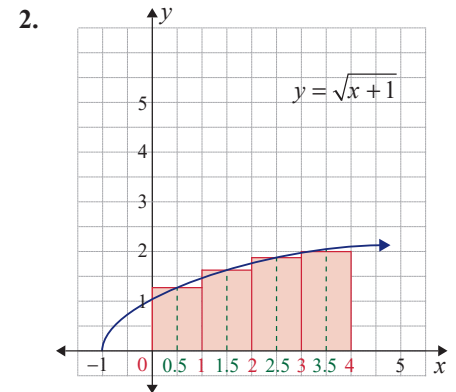
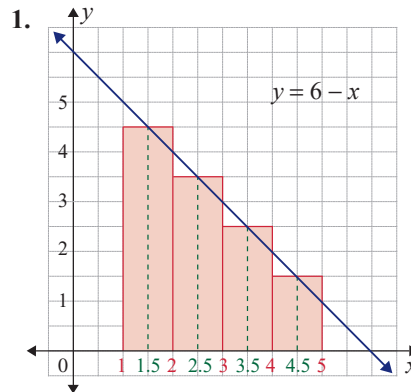

In Exercises 3–7, find the Riemann sum  $S_n$  for the given function, interval, and value of  $n$ .

- $f(x) = x^2$ ;  $[a, b] = [0, 4]$ ;  $n = 4$ ;  $c_1 = 0.5, c_2 = 1.5, c_3 = 2.5, c_4 = 3.5$
- $f(x) = 9 - x^2$ ;  $[a, b] = [-3, 2]$ ;  $n = 5$ ;  $c_1 = -2.5, c_2 = -1.5, c_3 = -0.5, c_4 = 0.5, c_5 = 1.5$
- $f(x) = \sqrt{2 - x}$ ;  $[a, b] = [-2, 2]$ ;  $n = 4$ ; Use the midpoint of each subinterval for the value of each  $c_k$ .
- $f(x) = \frac{1}{x+2}$ ;  $[a, b] = [-1, 3]$ ;  $n = 4$ ; Use the midpoint of each subinterval for the value of each  $c_k$ .
- $f(x) = 2 + x^2$ ;  $[a, b] = [0, 4]$ ;  $n = 4$ ; Use the midpoint of each subinterval for the value of each  $c_k$ .

 WRITING & THINKING

Use four rectangles to estimate the area between the graph of the given function and the  $x$ -axis on the given interval. Construct three estimates for the function: the first using the left endpoints of the subintervals as the sample points, the second using the right endpoints of the subintervals, and the third using the midpoints of the subintervals. Can you tell which are guaranteed to be underestimates or overestimates? (**Hint:** Consider the increasing/decreasing and concavity features of the graph. It is helpful to make a sketch.)

- $f(x) = \sqrt{x}$  on  $[0, 4]$
- $f(x) = \frac{x^3}{16}$  on  $[0, 4]$
- $f(x) = \frac{1}{x}$  on  $[1, 5]$
- $f(x) = \sqrt{4 - x^2}$  on  $[-2, 2]$
- $f(x) = e^{2-x}$  on  $[0, 2]$

## 6.4 EXERCISES

 PRACTICE

In Exercises 1–32, evaluate each definite integral.

1.  $\int_{-1}^0 5x^2 dx$

2.  $\int_1^4 \frac{1}{x} dx$

3.  $\int_0^3 (1 + e^x) dx$

4.  $\int_0^2 6e^x dx$

5.  $\int_3^5 \frac{1}{x-2} dx$

6.  $\int_1^9 \sqrt{x} dx$

7.  $\int_{-4}^{-2} \frac{1}{x^2} dx$

8.  $\int_2^4 (7x + 2) dx$

9.  $\int_{-1}^3 (4x + 1) dx$

10.  $\int_{-2}^1 \frac{4}{x+3} dx$

11.  $\int_{-1}^3 e^{x+1} dx$

12.  $\int_2^3 (x^2 + 2x - 4) dx$

13.  $\int_1^4 x(x^2 - 3) dx$

14.  $\int_1^8 \left(1 + \frac{1}{\sqrt[3]{x}}\right) dx$

15.  $\int_0^3 \frac{1}{3x+1} dx$

16.  $\int_1^3 2e^{-1.5x} dx$

17.  $\int_3^5 \frac{1}{(3x+1)^2} dx$

18.  $\int_{-1}^0 \sqrt{3x+4} dx$

19.  $\int_2^3 (3-2x)^4 dx$

20.  $\int_0^2 \frac{x}{\sqrt[3]{x^2+4}} dx$

21.  $\int_2^6 \frac{3x}{x^2-3} dx$

22.  $\int_3^5 \frac{x+2}{x^2+4x+3} dx$

23.  $\int_0^1 e^x (e^x + 1) dx$

24.  $\int_0^5 xe^{-0.24x^2} dx$

25.  $\int_1^3 xe^{x^2-1} dx$

26.  $\int_1^2 (x-1)(2x^2-4x+1)^2 dx$

27.  $\int_6^7 \frac{x-3}{\sqrt{x^2-6x+4}} dx$

28.  $\int_1^8 \left(2x^{\frac{2}{3}} - x^{-2}\right) dx$

29.  $\int_0^1 \frac{e^x}{e^x+1} dx$

30.  $\int_1^4 \frac{\ln x}{x} dx$

31.  $\int_1^3 \frac{1+\ln x}{x} dx$

32.  $\int_2^4 \frac{1}{x^2} e^{\frac{1}{x}} dx$

For Exercises 33–38, find the average value of the function on the given interval.

33.  $f(x) = x^2 + 6$ ;  $[1, 4]$

34.  $f(x) = 4x^2 - 3x + 1$ ;  $[-1, 3]$

35.  $f(x) = \sqrt{x+1}$ ;  $[3, 8]$

36.  $f(x) = \sqrt[3]{2x+1}$ ;  $[0, 13]$

37.  $f(x) = 2e^{-0.25x}$ ;  $[0, 4]$

38.  $f(x) = 1 + e^{-0.4x}$ ;  $[0, 5]$

 APPLICATIONS

- 39. Pollution:** The level of pollution in San Felipe Bay, due to an oil spill, is estimated to be  $f(t) = \frac{1800t}{\sqrt{t^2 + 11}}$  parts per million, where  $t$  is the time in days since the spill occurred. Find the average level of pollution during the first 5 days after the spill occurred.
- 40. Bacterial population:** It is estimated that the number of bacteria present in a culture  $t$  hours after bacteria are introduced to the culture is given by  $N(t) = \frac{8000}{\sqrt{8 - 0.5t}}$ . Find the average number of bacteria present during the first 8 hours.
- 41. Average production:** The daily production level for a product is given by  $N(t) = 240 - 240e^{-0.2t}$  units, where  $t$  is the time in hours after production begins. Find the average production during the first 4 hours.
- 42. Average marginal profit:** The marginal profit from the production and the sale of  $x$  barbecue grills is given by  $P'(x) = 52 - 0.8x$  dollars per grill. Find the average marginal profit for the first 40 grills produced and sold.

b. Integrate from  $x = 200$  to  $x = 400$ .

$$\begin{aligned} \int_{200}^{400} (20 - 0.05x) dx &= 20x - 0.025x^2 \Big|_{200}^{400} \\ &= [20(400) - 0.025(400)^2] - [20(200) - 0.025(200)^2] \\ &= (8000 - 4000) - (4000 - 1000) \\ &= 1000 \end{aligned}$$

His profit changes by \$1000 when sales increase from 200 to 400 frames.

Note that from parts a. and b. we see that the profit on sales for the first 200 frames ( $x = 0$  to  $x = 200$ ) is greater than the profit for the second 200 frames ( $x = 200$  to  $x = 400$ ). This result is quite reasonable because the marginal profit,  $P'(x) = 20 - 0.05x$ , is decreasing by 5 cents per frame. In this problem, the fixed costs are relevant. Suppose the fixed costs are \$1000. Then  $P(x) = 20x - 0.025x^2 - 1000$  dollars, and  $P(200) = \$2000$ , which is the **net profit**. The integral from  $x = 0$  to  $x = 200$  gives the increase in profits,  $P(200) - P(0) = 2000 - (-1000) = 3000$ .

## 6.5 EXERCISES

### 💡 PRACTICE

For Exercises 1–18, find the total area bounded by the  $x$ -axis and the curve  $y = f(x)$  on the indicated interval.

- $f(x) = 3x + 1$ ,  $[0, 5]$
- $f(x) = 7 - 2x$ ,  $[-1, 3]$
- $f(x) = x^2 + 1$ ,  $[-2, 2]$
- $f(x) = 0.5x^2 + 2$ ,  $[1, 4]$
- $f(x) = x^3 + 2$ ,  $[-1, 1]$
- $f(x) = 2x^3 - 1$ ,  $[1, 2]$
- $f(x) = x^2 + x + 1$ ,  $[-1, 3]$
- $f(x) = x^2 + 2x - 3$ ,  $[1, 3]$
- $f(x) = \frac{4}{x+1}$ ,  $[0, 3]$
- $f(x) = \frac{3}{2x+1}$ ,  $[0, 2]$
- $f(x) = 3e^{0.6x}$ ,  $[0, 5]$
- $f(x) = 1 + e^{-0.3x}$ ,  $[0, 4]$
- $f(x) = x^2 - 2x - 8$ ,  $[2, 5]$
- $f(x) = x^2 + 3x - 4$ ,  $[0, 4]$
- $f(x) = \begin{cases} 2 - x & \text{if } -1 \leq x \leq 2 \\ x^2 - 4 & \text{if } 2 \leq x \leq 3 \end{cases}$
- $f(x) = \begin{cases} x^2 & \text{if } -2 \leq x \leq 1 \\ 2x - 1 & \text{if } 1 \leq x \leq 2 \end{cases}$
- $f(x) = \begin{cases} x + 2 & \text{if } -2 \leq x \leq 0 \\ \sqrt{x+4} & \text{if } 0 \leq x \leq 5 \end{cases}$
- $f(x) = \begin{cases} 1 - 2x & \text{if } -2 \leq x \leq 0 \\ e^{2x} & \text{if } 0 \leq x \leq 1.5 \end{cases}$

 APPLICATIONS

- 19. Profit:** The marginal profit for a certain style of sports jacket is given by  $P'(x) = 56 - 0.8x$  dollars per jacket, where  $x$  is the number of jackets produced and sold weekly. Find the profit for the first 50 jackets that are produced and sold. (Ignore any fixed costs.)
- 20. Profit:** The marginal profit of an important product is given by  $P'(x) = 10 - 0.015e^{0.6x}$  dollars per item, where  $x$  is the number of items produced and sold. Find the profit for the first 8 items. (Ignore any fixed costs.)
- 21. Cost:** The marginal cost of a product is given by  $15 + \frac{4}{\sqrt{x}}$  dollars per unit, where  $x$  is the number of units produced. The current level of production is 100 units weekly. If the level of production is increased to 169 units weekly, find the increase in the total costs.
- 22. Revenue:** The marginal revenue from the sale of  $x$  bottles of a wine is given by  $8.4 - 0.3\sqrt{x}$  dollars per bottle. Find the increase in total revenue if the number of bottles sold is increased from 225 to 350.
- 23. Wildlife management:** The manager of a wildlife preserve has started a management program to control the population of the preserve's bison herd. It is estimated that the population will continue to grow according to the function  $N'(t) = 15 - 6t^{\frac{1}{2}}$  bison per year, where  $t$  is the number of years after implementation of the plan and  $0 \leq t \leq 5$ . Find the increase in the population during the first 4 years of the program.
- 24. Bacterial population:** It is estimated that  $t$  hours after some particular bacteria are introduced into a culture, the population will be increasing at a rate of  $P'(t) = \frac{1200}{(12 - 0.5t)^{\frac{1}{2}}}$  bacteria per hour. Find the increase in the population during the first 6 hours.

 WRITING & THINKING

In Exercises 25 and 26, explain the meaning of the shaded region in each graph.

25.

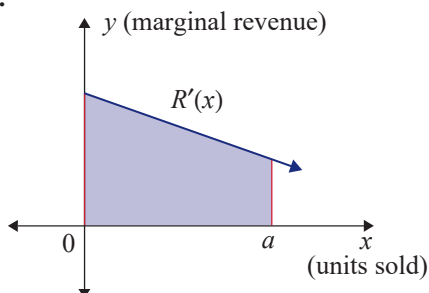

26.

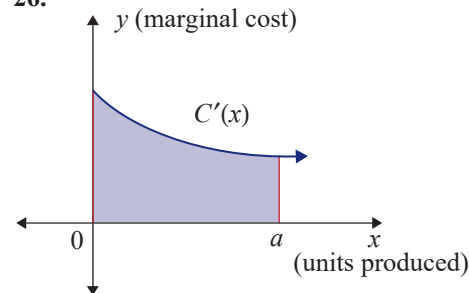

1. The domain is  $[0, 1]$ .
2. The range is  $[0, 1]$ .
3.  $f(0) = 0$  and  $f(1) = 1$ .
4.  $f(x) \leq x$  for all  $x$  in the interval  $[0, 1]$ .

#### Example 4: Using a Lorenz Curve

Suppose that  $f(x) = 0.6x^2 + 0.4x$  represents a Lorenz curve for some country.

- a. What percent of the country's total income is earned by the lower 50 percent of the families in this country?
- b. Find the coefficient of inequality.

#### Solution

$$\text{a. } f(0.5) = 0.6(0.5)^2 + 0.4(0.5) = 0.35$$

Since we want the lower 50% of families, set  $x = 0.5$ .

The lower 50 percent of the families earn 35 percent of the country's total income.

$$\begin{aligned} \text{b. } & 2 \int_0^1 [x - (0.6x^2 + 0.4x)] dx \\ &= 2 \int_0^1 [(0.6x - 0.6x^2)] dx \\ &= 2 \left[ \frac{0.6x^2}{2} - \frac{0.6x^3}{3} \right]_0^1 \\ &= 2 \left[ \left( \frac{0.6(1)^2}{2} - \frac{0.6(1)^3}{3} \right) - \left( \frac{0.6(0)^2}{2} - \frac{0.6(0)^3}{3} \right) \right] \\ &= 2[(0.3 - 0.2) - 0] \\ &= 0.2 \end{aligned}$$

Combine terms in the integrand before finding the antiderivative.

The coefficient of inequality is 0.2.

## 6.6 EXERCISES

### PRACTICE

In Exercises 1–16, find the area of the region bounded by the graphs of the given equations.

1.  $y = x^2$ ,  $y = x - 1$ ,  $x = -1$ ,  $x = 4$
2.  $y = x^2 + 2$ ,  $y = x$ ,  $x = 2$ ,  $x = 5$
3.  $y = x^3$ ,  $y = x^2$ ,  $x = 0$ ,  $x = 1$
4.  $y = x^2 + 1$ ,  $y = 1 - 2x$ ,  $x = 0$ ,  $x = 3$

5.  $y = \sqrt{2x+1}$ ,  $y = 3x+2$ ,  $x = 0$ ,  $x = 2$     6.  $y = e^{x-1}$ ,  $y = x$ ,  $x = 1$ ,  $x = 4$
7.  $y = e^{-x}$ ,  $y = x+1$ ,  $x = 0$ ,  $x = 3$     8.  $y = x^2 + 1$ ,  $y = e^{-0.2x}$ ,  $x = 0$ ,  $x = 4$
9.  $y = \frac{1}{x}$ ,  $y = \frac{5}{2} - x$ ,  $x = \frac{1}{2}$ ,  $x = 2$     10.  $y = \frac{1}{x+1}$ ,  $y = e^{0.7x}$ ,  $x = 0$ ,  $x = 2$
11.  $y = x+1$ ,  $y = x^2 + x$     12.  $y = x^2 + 1$ ,  $y = 6 - x$
13.  $y = \sqrt{x}$ ,  $y = x^2$     14.  $y = x^2 - 6x$ ,  $y = -x^2$
15.  $y = x^2 - 2x - 3$ ,  $y = 2x + 2$     16.  $y = x^2 + 5x - 1$ ,  $y = 2 - x^2$

For Exercises 17–21, determine the area pictured (check each answer using a graphing calculator if possible). In each case, you must determine the limits of integration if necessary.

17.

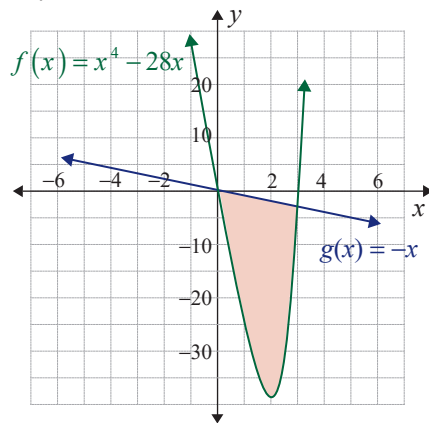

18.

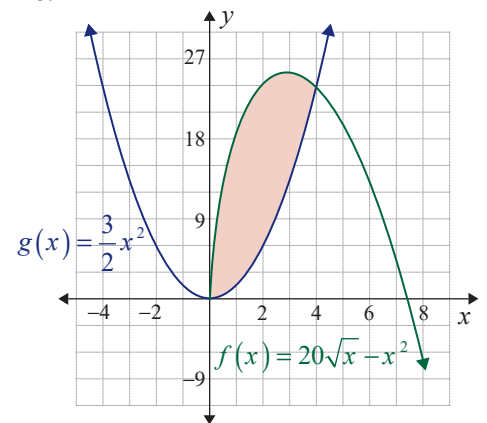

19.

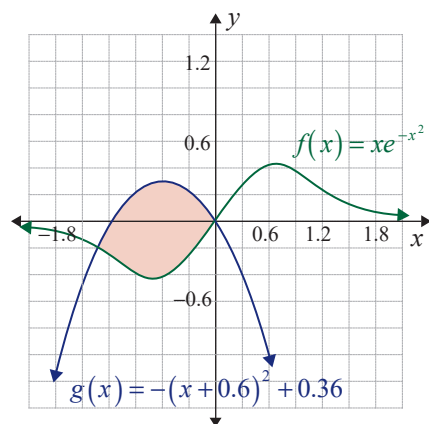

20.

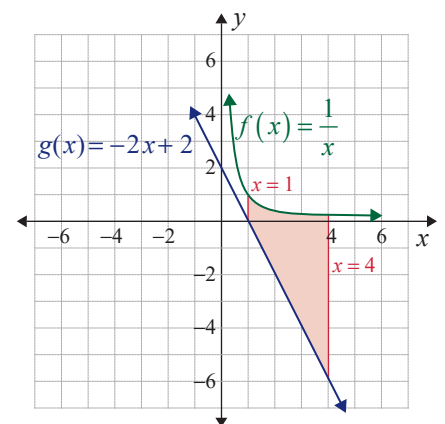

21.

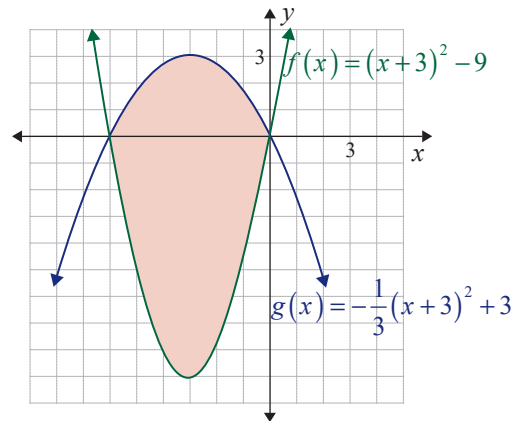

For each of the demand and supply functions in Exercises 22–25, find **a.** the equilibrium point, **b.** the consumers' surplus, and **c.** the producers' surplus.

22.  $D(x) = 18 - 0.4x$ ,  $S(x) = 3 + 0.1x$ ,  $0 \leq x \leq 40$

23.  $D(x) = 24 - 0.2x$ ,  $S(x) = 10 + 0.5x$ ,  $0 \leq x \leq 100$

24.  $D(x) = 1000 - 30x$ ,  $S(x) = 200 + 0.5x^2$ ,  $0 \leq x \leq 30$

25.  $D(x) = 66 - 5\sqrt{x}$ ,  $S(x) = 16 + x$ ,  $0 \leq x \leq 120$

### 🔑 APPLICATIONS

**26. Consumers' surplus:** The demand function for a particular product is given by the function  $D(x) = 24 - 0.6x - 0.03x^2$ . If  $x_E = 10$  units, find the consumers' surplus.

**27. Consumers' surplus:** Find the consumers' surplus for a product if the demand function is given by  $D(x) = \frac{800}{x+4}$  and  $x_E = 4$  units.

**28. Producers' surplus:** Find the producers' surplus for a product if the supply function is given by  $S(x) = 9e^{0.4x}$  and  $x_E = 5$  units.

**29. Producers' surplus:** The supply function for a product is given by the function  $S(x) = \sqrt{16 + 1.5x}$ . If  $x_E = 6$  units, find the producers' surplus.

**30. Consumers' and producers' surplus:** The demand curve for a product is given by  $D(x) = 18 - 3x$  and the corresponding supply curve is  $S(x) = 3x + 6$ . Find the consumers' surplus and the producers' surplus.

**31. Consumers' and producers' surplus:** The demand curve for a product is given by  $D(x) = 125 - 15x$  and the corresponding supply curve is  $S(x) = 50 + 10x$ . Find the equilibrium point, the CS, and the PS.

- 32. Lorenz curve:** The income distribution of a small country is estimated by the Lorenz curve  $f(x) = \frac{13}{18}x^2 + \frac{5}{18}x$ .
- What percentage of the country's total income is earned by the lower 80 percent of its families? Round to the nearest percentage point.
  - Find the coefficient of inequality.
- 33. Lorenz curve:** The Lorenz curve for estimating the income distribution of a country is given by  $f(x) = \frac{7}{16}x^2 + \frac{9}{16}x$ .
- What percentage of the country's total income is earned by the lower 70 percent of its families? Round to the nearest percentage point.
  - Find the coefficient of inequality.
- 34. Lorenz curve:** A study shows that the income distribution of farmers in a certain state is estimated by  $f(x) = 0.47x^3 + 0.24x^2 + 0.29x$ .
- What percentage of the state's farming income is earned by the lower 60 percent of the state's farmers? Round to the nearest percentage point.
  - Find the coefficient of inequality.
- 35. Lorenz curve:** In a certain state the income distribution for the lumber and the logging industry is estimated by  $f(x) = 1.16x^3 - 0.82x^2 + 0.66x$ .
- What percentage of the state's lumber and logging income is earned by the lower 50 percent of the companies? Round to the nearest percentage point.
  - Find the coefficient of inequality.
- 36. Lorenz curve:** The income distribution for a certain country in 1996 was estimated by the function  $f(x) = 0.34x + 0.66x^2$ . In 2000, the income distribution was estimated by the function  $f(x) = 0.3x + 0.72x^2 - 0.02x^3$ .
- Find the coefficient of inequality for each of the years.
  - Which year had a more equitable income distribution?
- 37. Lorenz curve:** The income distribution for country  $A$  is estimated by the function  $f(x) = 0.24x + 0.72x^2 + 0.04x^3$ . The income distribution for country  $B$  is estimated by the function  $f(x) = 0.28x + 0.69x^2 + 0.03x^3$ .
- Find the coefficient of inequality for each of the two countries.
  - Which country has a more equitable income distribution?

 TECHNOLOGY

For Exercises 38–41, use a graphing calculator to determine the area.

38.

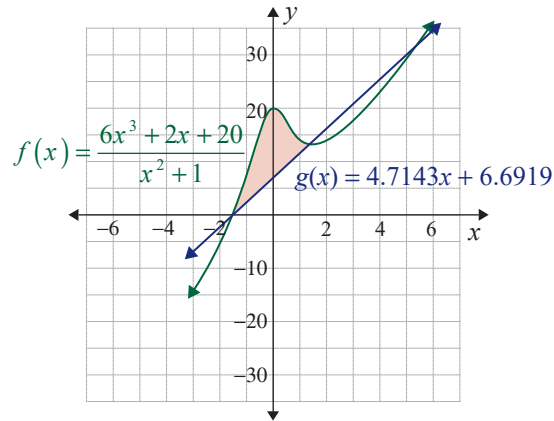

39.

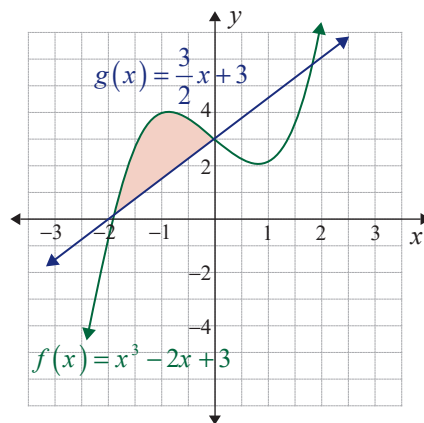

40.

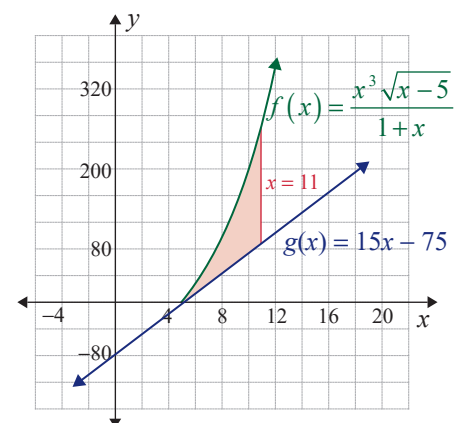

41.

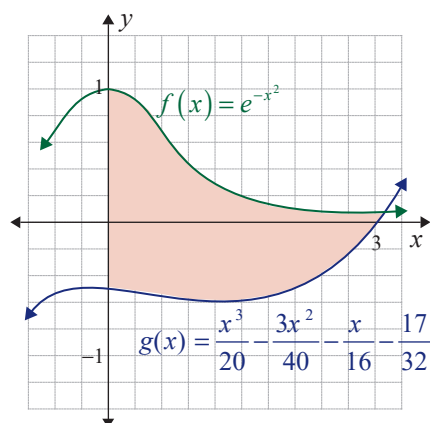

Thus the final form for  $P(t)$  is  $P(t) = \frac{10,000}{1 + 99e^{-0.14t}}$ .

Table 1 contains the general solutions of differential equations that arise in three basic growth applications.

Application	Differential Equation	General Solution
Unbounded growth	$\frac{dy}{dt} = ky$	$y = Ce^{kt}$
Bounded growth	$\frac{dy}{dt} = k(M - y)$	$y = M + Ce^{-kt}$
Logistic curve	$\frac{dy}{dt} = ky(M - y)$	$y = \frac{M}{1 + Ce^{-Mkt}}$

**TABLE 1:** General Solutions for Growth Applications

## 6.7 EXERCISES

### PRACTICE

In Exercises 1–12, verify that the differential equation has the given function as a particular solution.

1.  $\frac{dy}{dx} = 6$ ,  $y = 6x - 1$

2.  $\frac{dy}{dx} = 3x - 2$ ,  $y = \frac{3}{2}x^2 - 2x - 4$

3.  $\frac{dy}{dx} = 3 + y$ ,  $y = e^x - 3$

4.  $x \frac{dy}{dx} - x + 2 = 0$ ,  $y = x - 2 \ln x + 7$

5.  $\frac{dy}{dx} = y^{\frac{3}{2}}$ ,  $y = \frac{4}{(5-x)^2}$

6.  $\frac{dy}{dx} = -0.5y$ ,  $y = 3e^{-0.5x}$

7.  $2 \frac{dy}{dx} + 3y = 1$ ,  $y = \frac{1}{3} - 2e^{-1.5x}$

8.  $x \frac{dy}{dx} = xy + y$ ,  $y = 4xe^x$

9.  $2x^2y'' - xy' - 2y = 4 - 15x$ ,  $y = 3x^2 + 5x - 2$

10.  $x^2y'' + xy' - y + \ln x = 0$ ,  $y = x + \ln x$

11.  $x^2y'' - xy' + y = 0$ ,  $y = x \ln x$

12.  $y'' - 2y' + y = 0$ ,  $y = e^x(x + 2)$

In Exercises 13–20, find the solution of each separable differential equation.

13.  $\frac{dy}{dx} = 3x + \frac{1}{x}$

14.  $\frac{dy}{dx} = -3xy$

15.  $\frac{dy}{dx} = \frac{2y-1}{x+1}$

16.  $x \frac{dy}{dx} = \frac{x^2 + 1}{y^2}$

17.  $\frac{dy}{dx} = -0.4y$

18.  $\frac{dy}{dx} = -2(26 - y)$

19.  $\frac{dy}{dx} = (1 - 5x)y^2$

20.  $\frac{dy}{dx} = (x^2 + 1)e^{-y}$

In Exercises 21–32, solve each initial-value problem or obtain a general solution as indicated. (Refer to Table 1 in the text if necessary.)

21.  $\frac{dy}{dx} = 0.6y(20 - y)$

22.  $\frac{dy}{dx} = 0.3y(50 - y)$

23.  $\frac{dy}{dx} = 0.25y$ ,  $y = 5$  when  $x = 0$

24.  $\frac{dy}{dx} = -3x$ ,  $y = 10$  when  $x = 2$

25.  $x \frac{dy}{dx} = y + 1$ ,  $y = 14$  when  $x = 3$

26.  $\frac{dy}{dx} = -2xy$ ,  $y = 18$  when  $x = 0$

27.  $\frac{dy}{dx} = -6x^2y^2$ ,  $y = 2$  when  $x = 1$

28.  $\frac{dy}{dx} = \frac{xy}{x^2 + 1}$ ,  $y = 7$  when  $x = 0$

29.  $\frac{dy}{dx} = 8x + 2xy$ ,  $y = 10$  when  $x = 0$

30.  $\frac{dy}{dx} = 0.3(80 - y)$ ,  $y = 60$  when  $x = 0$

31.  $\frac{dy}{dx} = 0.8y(40 - y)$ ,  $y = 30$  when  $x = 0$

32.  $\frac{dy}{dx} = 0.04y(60 - y)$ ,  $y = 10$  when  $x = 0$

### APPLICATIONS

33. **Elasticity of demand:** The elasticity of demand for a product is given by  $E = 1.5$ . Find the demand function  $p = D(x)$  if  $D(8) = 24$ .

34. **Elasticity of demand:** The elasticity of demand for a product is given by  $E = 2$ . Find the demand function  $p = D(x)$  if  $D(25) = 30$ .

35. **Elasticity of demand:** The elasticity of demand for a product is given by  $E = \frac{2(120 - x)}{x}$ . Find the demand function  $p = D(x)$  if  $D(20) = 180$ .

36. **Elasticity of demand:** The elasticity of demand for a product is given by  $E = \frac{60 - 0.4x}{0.2x}$ . Find the demand function  $p = D(x)$  if  $D(70) = 28$ .

- 37. Resale value:** The resale or salvage value  $V$  of a machine decreases at a rate proportional to its value. Thus  $\frac{dV}{dt} = -kV$ , where  $t$  is the machine's age in years and  $k$  is its rate of decrease in value.
- Find the expression for the value when the machine is  $t$  years old if the original value was \$24,000 and the rate of decrease is 6 percent.
  - Find the value of the machine when it is 7 years old.
- 38. Drug concentration:** The amount  $A$  of a drug remaining in a body  $t$  hours after an injection decreases at a rate proportional to the amount present. This suggests the differential equation  $\frac{dA}{dt} = -kA$ . The amount of a certain drug decreases at a rate of 3 percent per hour. Find the amount of the drug remaining in the body 4 hours after an injection of 20 cc of the drug.
- 39. Newton's Law of Cooling:** Newton's Law of Cooling states that the rate at which the temperature  $T$  of an object changes is proportional to the difference between the temperature of the object and the temperature of the surrounding medium. That is  $\frac{dT}{dt} = -k(T - M)$ , where  $k$  is the constant of proportionality,  $t$  is time, and  $M$  is the constant temperature of the medium.
- Solve the differential equation for  $T(t)$ .
  - Find  $T(5)$ , if  $T(0) = 78^\circ$ ,  $M = 26^\circ$ , and  $k = 0.3$ .
- 40. Newton's Law of Cooling:** The temperature of a roast was  $160^\circ$  when it was removed from an oven and placed in a room with constant temperature of  $76^\circ$ . After 10 minutes, the temperature of the roast was  $152^\circ$ . Find the temperature 20 minutes after the roast was removed from the oven. (See Exercise 39.)
- 41. Spread of a rumor:** In a small community with a population of 2800, a rumor about the mayor was started. The rate at which the rumor spread was approximated by  $\frac{dN}{dt} = 0.0003N(2800 - N)$  people per day, where  $N$  is the number of people who have heard the rumor  $t$  days after the rumor was started.
- Write an equation for  $N(t)$ , assuming that 20 people have heard the rumor at  $t = 0$ .
  - How many days will it take for 1500 people to hear the rumor? Round to the nearest day.
- 42. Spread of a disease:** The population of seals on an island is about 600. Biologists estimate that there are 12 seals with a very infectious disease. The disease will spread at a rate  $\frac{dN}{dt} = 0.006N(600 - N)$  seals per day, where  $N$  is the number of infected seals  $t$  days after the discovery of the disease.
- Write a function  $N(t)$  for the number of seals infected  $t$  days after the discovery of the disease.
  - At what time  $t$  will 300 seals will be infected? Round to the nearest day.

## Example 4: Integration by Parts

Evaluate the definite integral  $\int_1^5 x\sqrt{x-1} dx$ .

## Solution

$u = x$	$dv = \sqrt{x-1} dx$
$du = dx$	$v = \int (x-1)^{\frac{1}{2}} dx = \frac{2}{3}(x-1)^{\frac{3}{2}}$

Now we evaluate the definite integral using the formula for integration by parts.

$$\begin{aligned}
 \int u dv &= uv - \int v du \\
 \int_1^5 x\sqrt{x-1} dx &= x \cdot \frac{2}{3}(x-1)^{\frac{3}{2}} \Big|_1^5 - \int_1^5 \frac{2}{3}(x-1)^{\frac{3}{2}} dx \\
 &= \frac{2}{3}x(x-1)^{\frac{3}{2}} \Big|_1^5 - \frac{2}{3} \cdot \frac{2}{5}(x-1)^{\frac{5}{2}} \Big|_1^5 \\
 &= \frac{2}{3}x(x-1)^{\frac{3}{2}} - \frac{4}{15}(x-1)^{\frac{5}{2}} \Big|_1^5 \\
 &= \left[ \frac{10}{3}(4)^{\frac{3}{2}} - \frac{4}{15}(4)^{\frac{5}{2}} \right] - (0) \\
 &= \frac{80}{3} - \frac{128}{15} \\
 &= \frac{400}{15} - \frac{128}{15} \\
 &= \frac{272}{15}
 \end{aligned}$$

## 7.1 EXERCISES

 PRACTICE

In Exercises 1–16, use the technique of integration by parts to find the integrals.

1.  $\int xe^{2x} dx$

2.  $\int 3xe^{-x} dx$

3.  $\int 2ye^{0.5y} dy$

4.  $\int 5te^{0.4t} dt$

5.  $\int \ln t dt$

6.  $\int y^2 \ln y dy$

7.  $\int x^3 \ln 5x dx$

8.  $\int 8x \ln 3x dx$

9.  $\int x\sqrt{x+2} dx$

10.  $\int x\sqrt{x-3} dx$

11.  $\int x(x+4)^{-2} dx$

12.  $\int x(x-1)^{-3} dx$

13.  $\int \frac{t}{2e^{0.6t}} dt$

14.  $\int y^2 e^{3y} dy$

15.  $\int \sqrt{x} \ln 7x dx$

16.  $\int 3x(x-6)^{-\frac{2}{3}} dx$

In Exercises 17–22, use the technique of integration by parts to evaluate each definite integral. Round your answer to the nearest hundredth.

17.  $\int_0^2 xe^{-2x} dx$

18.  $\int_0^3 (x+1)e^{-0.5x} dx$

19.  $\int_0^1 (x+2)e^{-4x} dx$

20.  $\int_0^4 (1-2x)e^{1.2x} dx$

21.  $\int_{-2}^3 \frac{x}{\sqrt{6+x}} dx$

22.  $\int_0^4 x\sqrt{1+2x} dx$

In each of Exercises 23–30, identify the  $u$  and  $dv$  which would solve the integral using integration by parts. Then evaluate the integral and round your answer to the nearest hundredth.

23.  $\int_0^1 4x(3x+1)^5 dx$

24.  $\int_1^2 \frac{x}{\sqrt{2x+5}} dx$

25.  $\int_{-1}^2 (x+1)(x+2)^{\frac{3}{2}} dx$

26.  $\int_1^4 \sqrt{x} \ln x dx$

27.  $\int_1^5 x^2 \ln x dx$

28.  $\int_1^3 \frac{\ln t}{t^2} dt$

29.  $\int_0^6 \ln(x+1) dx$

30.  $\int_1^2 (2x+1) \ln x dx$

In Exercises 31–40, use the technique of substitution or integration by parts to evaluate the integrals.

31.  $\int 5te^{-2t} dt$

32.  $\int 5te^{-2t^2} dt$

33.  $\int \sqrt{3x} \ln x dx$

34.  $\int \frac{\ln x}{x} dx$

35.  $\int 3x(2x^2-1)^{\frac{3}{2}} dx$

36.  $\int 3x(2x-1)^{\frac{3}{2}} dx$

37.  $\int \frac{(\ln x)^2}{x} dx$

38.  $\int x \ln x^2 dx$

39.  $\int \frac{e^x}{1-e^x} dx$

40.  $\int \frac{x}{\sqrt{5x^2-3}} dx$

## APPLICATIONS

**41. Demand for a natural resource:** The demand for a natural resource  $t$  years from now will be increasing at a rate of  $te^{0.01t}$  million units per year. If the current demand is 80 million units, write a function for the demand  $t$  years from now.

**42. Revenue:** The marginal revenue for  $x$  units of a product is given by  $R'(x) = (200 - 30x)e^{-0.15x}$  dollars per unit. Find the revenue function  $R(x)$  if  $R(0) = 0$ .

**43. Revenue:** The marginal revenue for  $x$  units of a product is given by  $R'(x) = 18 - 0.4 \ln x$  dollars per unit, where  $x \geq 1$ . Find the revenue function if  $R(1) = \$18.40$ .

**44. Resale value:** The value of a machine depreciates at a rate of  $-200t(t+1)^{-2}$  dollars per year, where  $t$  is the age (in years) of the machine. If the original cost of the machine is \$540, find a function for the value of the machine when it is  $t$  years old.

$$\begin{aligned}
 PV &= (50,000 + 2000t)(-10e^{-0.10t}) \Big|_0^5 - \int_0^5 (-10e^{-0.10t})(2000dt) && \text{Using the parts} \\
 &= (50,000 + 2000t)(-10e^{-0.10t}) \Big|_0^5 + 20,000 \int_0^5 e^{-0.10t} dt && \text{formula, } uv - \int vdu \\
 &= (50,000 + 2000t)(-10e^{-0.10t}) \Big|_0^5 + (-200,000e^{-0.10t}) \Big|_0^5 \\
 &= 60,000(-10e^{-0.5}) + 500,000 - 200,000(e^{-0.5}) + 200,000 \\
 &= 700,000 - 800,000e^{-0.5} \\
 &\approx 700,000 - 800,000(0.6065307) \\
 &\approx 700,000 - 485,225 = 214,775
 \end{aligned}$$

The present value of the new store's income stream is approximately \$214,775.

## 7.2 EXERCISES

### APPLICATIONS

- Annuity:** Estimate the amount of an annuity if \$1000 is deposited annually for 10 years at a rate of 8 percent compounded continuously.
- Annuity:** An amount of \$6000 is invested in an account each year for 8 years. Find the approximate balance at the end of the 8 years if the account pays interest at a rate of 7 percent compounded continuously.
- Annuity:** Christine has decided to invest \$2000 each year into an IRA account that pays interest at the rate of 9 percent compounded continuously. Find the amount in the account at the end of 15 years.
- Annuity:** Bob and Ann plan to deposit \$4000 per year into their retirement account. If the account pays interest at a rate of 8.4 percent compounded continuously, approximately how much will be in their account after 12 years?
- Annuity:** Bryan plans to deposit \$1200 each year into an annuity. If the account pays interest at a rate of 7.5 percent compounded continuously, find the approximate balance of his account after 10 years.
- Annuity:** Seven thousand dollars is invested in an annuity account each year for 4 years. Find the approximate balance in the account after 4 years if the rate of interest is 6.8 percent compounded continuously.
- Income stream:** Find the value of an income stream after 7 years if the rate of flow is estimated to be \$200,000 annually and the income is invested at a rate of 8 percent compounded continuously.
- Income stream:** The owner of a local convenience store estimates that the store will generate an annual income of \$340,000 for the next 4 years. If the rate of interest is 9 percent compounded continuously, find the value of the income stream.

9. **Income stream:** What is the eventual sum accumulated by an income stream of \$1200 per year for 15 years assuming continuous compounding at an annual rate of 5%?
10. **Income stream:** A hot dog stand profits by \$90 per day (or \$32,850 per year) over salaries and expenses. Assuming continuous compounding at an annual rate of 4%, what will be the accumulated profits in 6 years?
11. **Income stream:** A real estate investment is expected to generate an income flow of \$12,000 annually for the next 6 years. Find the amount of the income stream if the interest rate is 7.8 percent compounded continuously.
12. **Income stream:** Find the value of an income stream after 5 years if  $R(t) = 3600e^{0.02t}$  is the rate of flow of revenue and the income is deposited at a rate of 7 percent compounded continuously.
13. **Income stream:** A certain investment has a continuous flow of money at a rate of  $R(t) = 7200e^{0.01t}$ . Find the value of this flow after 4 years if the interest rate is 8.2 percent compounded continuously.
14. **Income stream:** The rate of income from a number of vending machines is estimated by  $R(t) = 80e^{0.015t}$  thousand dollars per year. If the receipts are reinvested into an account paying 5.5 percent compounded continuously, find the amount of the income stream after 5 years.
15. **Income stream:** Find the value of an income stream in 6 years if the rate of flow of income at time  $t$  is estimated by the function  $R(t) = 2000 + 800t$  dollars per year and the income is reinvested at 8 percent compounded continuously.
16. **Income stream:** Find the value of an income stream if  $R(t) = 50 + 0.2t$  is the rate of flow of revenue reinvested at 6 percent compounded continuously for 8 years.
17. **Income stream:** Find the value of an income stream if  $R(t) = 80 + 1.2t$  is the rate of flow of revenue reinvested at 6.4 percent compounded continuously over the next 6 years.
18. **Income stream:** The profit from a number of soft drink machines is estimated to be at the rate of  $R(t) = 15 + 0.8t$  thousand dollars per year. If the profits are deposited into an account paying 6.5 percent compounded continuously, find the amount of the income stream after 7 years.
19. **Income stream:** It is estimated that a computer will save accounting fees at a small company at a rate of  $R(t) = 4 + 0.6t$  thousand dollars per year. If the savings are reinvested at 5 percent compounded continuously, find the amount of the income stream after 4 years.
20. **Income stream:** Find the present value of an income stream with  $R(t) = 60 - 0.4t$ ,  $r = 8$  percent, and  $T = 20$ .
21. **Income stream:** Find the present value of an income stream with  $R(t) = 150 - t$ ,  $r = 12$  percent, and  $T = 10$ .

22. **Income stream:** The rate of flow of an income stream is estimated by  $R(t) = 6000e^{0.015t}$  for the next 4 years. Find the present value of this flow if the interest rate is 6 percent compounded continuously.
23. **Income stream:** The rate of flow of an income stream for the next 6 years is estimated by  $R(t) = 10,000e^{-0.01t}$ . Find the present value of this flow if the interest rate is 8.5 percent compounded continuously.
24. **Income stream:** Sandy estimates that the profits from his ice cream store will be  $R(t) = 24 + 3.6t$  thousand dollars per year for the next 5 years. Find the present value of the store if the current interest rate is 10 percent compounded continuously.
25. **Income stream:** An income stream is expected to generate revenues at a rate given by  $R(t) = 18 + 2.4t$  thousand dollars per year for the next 6 years. Find the present value of the stream if the interest rate is 8.5 percent compounded continuously.
26. **Income stream:** Elco Grain Company expects their profits to be  $R(t) = 30 + 12e^{0.02t}$  thousand dollars per year for the next 4 years. If the current interest rate is 8 percent compounded continuously, find the present value of the company.

 **WRITING & THINKING**

27. In Figure 1, replace the column information with  $100e^{0.01(5)}$ ,  $100e^{0.01(4)}$ ,  $100e^{0.01(3)}$ ,  $100e^{0.01(2)}$ ,  $100e^{0.01(1)}$ ,  $100e^{0.01(0)}$ . This suggests that the future value of an annuity could be given by  $\int_0^N Pe^{rt} dt$ . Does this give the same result as the formula for the future value of an annuity shown in the lesson? Explain why or why not.

$$\begin{aligned}\int \frac{1}{(x+2)(x+3)} dx &= \frac{1}{3-2} \ln \left| \frac{x+2}{x+3} \right| + C_2 \\ &= \ln \left| \frac{x+2}{x+3} \right| + C_2 \\ &= \ln|x+2| - \ln|x+3| + C_2\end{aligned}$$

Now combining the parts gives the result.

$$\begin{aligned}\int \frac{x+1}{x^2+5x+6} dx &= 3\ln|x+3| - 2\ln|x+2| + C_1 + \ln|x+2| - \ln|x+3| + C_2 \\ &= 2\ln|x+3| - \ln|x+2| + C \quad \text{Where } C = C_1 + C_2\end{aligned}$$

## 7.3 EXERCISES

### PRACTICE

Use Table 1 to find the following integrals.

- |                                       |                                       |                                      |
|---------------------------------------|---------------------------------------|--------------------------------------|
| 1. $\int \frac{1}{4x+3} dx$           | 2. $\int \sqrt{9x+2} dx$              | 3. $\int e^{-0.15x} dx$              |
| 4. $\int \ln x dx$                    | 5. $\int \frac{1}{(2x-5)^2} dx$       | 6. $\int \frac{x}{x+6} dx$           |
| 7. $\int x\sqrt{3x-4} dx$             | 8. $\int \frac{x}{(2x+1)(x-2)} dx$    | 9. $\int \sqrt{x^2+36} dx$           |
| 10. $\int x^4 \ln x dx$               | 11. $\int \frac{1}{x^2-16} dx$        | 12. $\int \frac{1}{x(4x-3)} dx$      |
| 13. $\int \frac{1}{(x+8)(5x-1)} dx$   | 14. $\int \frac{1}{2+e^{3x}} dx$      | 15. $\int 7x^5 \ln x dx$             |
| 16. $\int x^4 e^{-2x} dx$             | 17. $\int \frac{1}{8-5e^{-0.7x}} dx$  | 18. $\int \frac{1}{(0.3x+2)^2} dx$   |
| 19. $\int \frac{2}{x(3x-1)} dx$       | 20. $\int \frac{4}{x^2-8} dx$         | 21. $\int 14\sqrt{6x-5} dx$          |
| 22. $\int \frac{13}{(4x-1)(2x+3)} dx$ | 23. $\int \frac{8}{x(0.4x+1)} dx$     | 24. $\int 2x\sqrt{3x-4} dx$          |
| 25. $\int x^3 e^{1.5x} dx$            | 26. $\int \sqrt{x^2+9} dx$            | 27. $\int \frac{x}{(x-7)(5x+2)} dx$  |
| 28. $\int \sqrt{x^2-15} dx$           | 29. $\int \frac{1}{\sqrt{x^2-12}} dx$ | 30. $\int \frac{6}{24-9e^{3.1x}} dx$ |

Type the function, the variable of integration  $x$ , the lower limit, the upper limit, a right parenthesis, and **enter**. The four items within the parentheses must be separated by commas. (**Note:** You may use any number for the upper limit; for this function 100 works well.)

The calculator will return **0.0442551719**, a more accurate answer than the result from Method 1 (see Figure 7).

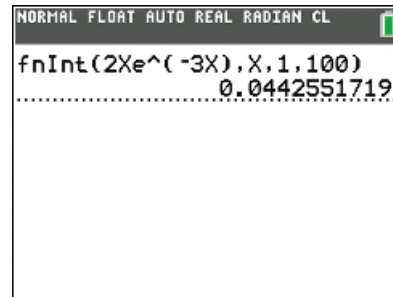

FIGURE 7

## 7.4 EXERCISES

### 💡 PRACTICE

In Exercises 1–10, find the limit if it exists.

1.  $\lim_{b \rightarrow +\infty} \frac{1}{b}$

2.  $\lim_{b \rightarrow +\infty} \frac{1}{\sqrt[3]{b}}$

3.  $\lim_{b \rightarrow +\infty} \frac{\sqrt{b}}{20}$

4.  $\lim_{b \rightarrow +\infty} e^{0.1b}$

5.  $\lim_{b \rightarrow +\infty} e^{-4b}$

6.  $\lim_{b \rightarrow +\infty} (-12 \ln b)$

7.  $\lim_{b \rightarrow +\infty} \left( 2 + \frac{9}{\sqrt{3b+1}} \right)$

8.  $\lim_{b \rightarrow +\infty} (5 + e^{-2b})$

9.  $\lim_{b \rightarrow +\infty} (7b^4 e^{-b})$

10.  $\lim_{b \rightarrow +\infty} (7b+2)^{\frac{2}{3}}$

In Exercises 11–34, determine whether the improper integrals are convergent or divergent, and evaluate those that are convergent.

11.  $\int_2^{+\infty} \frac{4}{x^3} dx$

12.  $\int_1^{+\infty} \frac{1}{\sqrt[3]{x}} dx$

13.  $\int_8^{+\infty} x^{-\frac{2}{3}} dx$

14.  $\int_4^{+\infty} 5x^{-\frac{3}{2}} dx$

15.  $\int_{20}^{+\infty} 3e^{-x} dx$

16.  $\int_4^{+\infty} e^{-2x} dx$

17.  $\int_2^{+\infty} e^{\frac{x}{3}} dx$

18.  $\int_2^{+\infty} 4e^{-0.5x} dx$

19.  $\int_2^{+\infty} e^{1.5x} dx$

20.  $\int_{-1}^{+\infty} \frac{1}{80} e^{0.16x} dx$

21.  $\int_0^{+\infty} \frac{1}{(x+3)^2} dx$

22.  $\int_0^{+\infty} \frac{4}{\sqrt{3x+1}} dx$

23.  $\int_{-1}^{+\infty} \frac{2}{\sqrt[3]{2x+3}} dx$

24.  $\int_2^{+\infty} (3x+2)^{\frac{4}{3}} dx$

25.  $\int_0^{+\infty} \frac{5}{x+1} dx$

26.  $\int_0^{+\infty} (5x+4)^{-\frac{3}{2}} dx$

27.  $\int_0^{+\infty} x^2 e^{-x^3} dx$

28.  $\int_0^{+\infty} -4xe^{x^2} dx$

29.  $\int_1^{+\infty} xe^{1-x^2} dx$

30.  $\int_0^{+\infty} 7xe^{-x^2} dx$

31.  $\int_2^{+\infty} \frac{1}{x(\ln x)^3} dx$

32.  $\int_e^{+\infty} \frac{1}{x \ln x} dx$

33.  $\int_0^{+\infty} xe^{-x} dx$

34.  $\int_0^{+\infty} xe^{-0.2x} dx$

In Exercises 35–38, find the area, if it exists, of the region under the curve  $y = f(x)$  on the given interval of the  $x$ -axis.

35.  $f(x) = \frac{4}{x^2}, x \geq 2$

36.  $f(x) = 3e^{-x}, x \geq 0$

37.  $f(x) = \frac{3}{x}, x \geq 6$

38.  $f(x) = 2e^{0.8x}, x \geq 0$

### WRITING & THINKING

39. The integral  $\int_1^{+\infty} \frac{1}{x^p} dx$  converges if and only if (choose all that apply):

- $0 < p < 1$
- $p \neq 1$
- $p$  is an integer greater than or equal to 2
- $p > 1$
- $p$  is positive
- none of the above

### TECHNOLOGY

40. Integrate  $\int_1^{+\infty} 2xe^{-3x} dx$  by evaluating the limit and compare your answer to the calculator values obtained at the end of the section.

### Solution

We must evaluate  $\int_0^{+\infty} t(0.01e^{-0.01t}) dt$ . We use either integration by parts or formula 20 from Table 1 in Section 7.3 to get the antiderivative

$$-te^{-0.01t} - \frac{1}{0.01}e^{-0.01t} = -\frac{t}{e^{0.01t}} - \frac{100}{e^{0.01t}}.$$

Now we evaluate the integral using limits:  $\mu = \lim_{b \rightarrow +\infty} \left( -\frac{b}{e^{0.01b}} - \frac{100}{e^{0.01b}} \right) - (0 - 100) = 100$ , since the limit expression goes to zero. Thus, the average duration of a hair appointment is 100 minutes, or 1 hour and 40 minutes.

Note that the constant  $k$  in the probability density function for an exponential distribution is all that is needed to find the mean value; that is,  $\mu = \frac{1}{k}$ .

## 7.5 EXERCISES

### PRACTICE

In Exercises 1–12, show that each function is a probability density function on the given interval. If the function is not a probability density function on the given interval, explain why.

1.  $f(x) = \frac{3}{16}\sqrt{x}$ ,  $[0, 4]$

2.  $f(x) = \frac{4}{45}\sqrt[3]{x}$ ,  $[1, 8]$

3.  $f(x) = \frac{4}{15}\left(\frac{1}{2}x + 1\right)$ ,  $[-1, 2]$

4.  $f(x) = \frac{1}{4}(x + 1)$ ,  $[0, 2]$

5.  $f(x) = \frac{3}{68}(x - \sqrt{x})$ ,  $[1, 9]$

6.  $f(x) = \frac{2}{13}\left(x + \frac{2}{x}\right)$ ,  $[2, 4]$

7.  $f(x) = \frac{1}{2x}$ ,  $[1, e^2]$

8.  $f(x) = \frac{1}{3x}$ ,  $[1, e^3]$

9.  $f(x) = \frac{3}{32}(4 - x^2)$ ,  $[-2, 2]$

10.  $f(x) = 6(\sqrt{x} - x)$ ,  $[0, 1]$

11.  $f(x) = 2e^{-2x}$ ,  $[0, +\infty)$

12.  $f(x) = \frac{1}{10}e^{-0.1x}$ ,  $[0, +\infty)$

In Exercises 13–20, **a.** determine the value of  $k$  such that the function is a probability density function on the given interval and **b.** determine the average or expected value of  $x$ .

13.  $f(x) = k(3 - x)$ ,  $[0, 3]$

14.  $f(x) = k(5 - 2x)$ ,  $[-1, 2]$

15.  $f(x) = \frac{k}{\sqrt{x}}$ ,  $[1, 4]$

16.  $f(x) = ke^{2x}$ ,  $[0, 1]$

17.  $f(x) = ke^{-0.25x}$ ,  $[0, +\infty)$

18.  $f(x) = ke^{-0.5x}$ ,  $[2, +\infty)$

19.  $f(x) = \frac{k}{x^3}$ ,  $[1, 4]$

20.  $f(x) = \frac{k}{(x+1)^2}$ ,  $[0, 7]$

21. An experiment has the probability density function  $f(x) = \frac{2}{9}(3x - x^2)$ , where  $0 \leq x \leq 3$ . Find the probability that  $x$  is between 1 and 2.
22. The probability density function for an experiment is  $f(x) = \frac{1}{3x}$ , where  $1 \leq x \leq e^3$ . Find the probability that  $x$  is between 1 and 10.
23. The exponential probability density function for an experiment is given by  $f(x) = 0.4e^{-0.4x}$ , where  $x \geq 0$ . What is the probability that  $x \geq 10$ ?
24. The outcomes of an experiment are distributed exponentially according to  $f(x) = 0.7e^{-0.7x}$ , where  $x \geq 0$ . What is the probability that  $10 \leq x \leq 20$ ?

### APPLICATIONS

25. **Waiting time:** The average waiting time in minutes for a shuttle at the airport parking lot has the probability density function  $f(t) = \frac{1}{20}$ , where  $0 \leq t \leq 20$ . What is the probability that you will wait at least 12 minutes? What is the average waiting time?
26. **Travel time:** The length of time  $t$  (in minutes) it requires Frank to get to work ranges from 25 to 40 minutes. The probability density function is  $f(t) = \frac{1}{15}$ , where  $25 \leq t \leq 40$ . If Frank allots himself 36 minutes to get to work, what is the probability that he will be late? If he leaves his house at 8:00 a.m., what is his average arrival time?
27. **Reaction time:** The length of time  $t$  (in seconds) that it takes the body to react to the injection of a particular drug has the probability density function  $f(t) = \frac{81}{40t^3}$ , where  $1 \leq t \leq 9$ . What is the probability that it will take at least 6 seconds for the body to react to the drug? What is the average waiting time for the body to react?
28. **Waiting time:** The length of time  $t$  (in minutes) that you and your friends will wait to be seated at a popular restaurant has the probability density function  $f(t) = \frac{26}{25(t+1)^2}$ , where  $0 \leq t \leq 25$ . What is the probability that you will wait between 5 and 10 minutes?
29. **Reliability:** A particular TV model has a 2-year warranty. The probability density function for the number of years  $t$  that this TV model will last without needing any repairs is  $f(t) = 0.15e^{-0.15t}$ . What is the probability that this type of TV will need repairs before it is 2 years old?
30. **Traffic spacing:** On the freeway, the distance  $x$  (in feet) between your car and the car behind you has the probability density function  $f(x) = 0.02e^{-0.02x}$ , where  $x \geq 0$ . What is the probability that the car behind you is within 30 feet of you?

We have considered only solids of revolution in which a region is rotated about the  $x$ -axis. The formula we used would need some adjustment if the region were rotated about some other horizontal line, since the radius of revolution would be represented by some expression other than  $f(x)$ . Such solids of revolution will not be considered in this course.

## 7.6 EXERCISES

### PRACTICE

Find the volume of the solid generated when the region bounded by the graphs of the given equations and the  $x$ -axis is rotated about the  $x$ -axis.

1.  $y = x, x = 0, x = 2$

2.  $y = 3x, x = 1, x = 3$

3.  $y = 2\sqrt{x}, x = 0, x = 4$

4.  $y = \sqrt[3]{x}, x = 0, x = 8$

5.  $y = e^x, x = -1, x = 2$

6.  $y = e^{-x}, x = -1, x = 2$

7.  $y = 1 + e^{-x}, x = 0, x = 3$

8.  $y = x^3 + 1, x = 0, x = 2$

9.  $y = 6 - x^2, x = -1, x = 2$

10.  $y = \sqrt{4 - x}, x = 0, x = 4$

11.  $y = 1 - x^2, x = -1, x = 1$

12.  $y = 4 - x^2, x = -2, x = 2$

13.  $y = (16 - x^2)^{\frac{1}{2}}, x = 0, x = 4$

14.  $y = \sqrt{3 - x^2}, x = 0, x = 1$

15.  $y = \sqrt{9 - x^2}, x = 0, x = 3$

16.  $y = \frac{4}{x}, x = 1, x = 3$

17.  $y = \frac{2}{x}, x = 1, x = 2$

18.  $y = \frac{1}{\sqrt{x}}, x = 1, x = 6$

19.  $y = \frac{2}{\sqrt{x}}, x = 1, x = 5$

20.  $y = x + \sqrt{x}, x = 1, x = 4$

21.  $y = \sqrt{x} - x, x = 0, x = 1$

22.  $y = 16(x - x^3), x = 0, x = 1$

23.  $y = 2 + x + x^2, x = 0, x = 1$

24.  $y = (5 - x)e^{0.5x}, x = 0, x = 2$

25. Determine the volume, if finite, of the solid of revolution formed when the region between  $y = 12e^{-3x}$  and the  $x$ -axis on the interval  $[0, +\infty)$  is revolved about the  $x$ -axis.

## 8.1 EXERCISES

 PRACTICE

In Exercises 1–15, find the indicated function values, if possible.

1.  $f(x, y) = 12x - 3y + xy$

a.  $f(1, 3)$

b.  $f(0, 4)$

2.  $f(x, y) = 7xy - 11x + 9y$

a.  $f(-2, 1)$

b.  $f(3, -2)$

3.  $f(x, y) = 4x^2 - 3xy + y^2$

a.  $f(2, 5)$

b.  $f(0, 3)$

4.  $g(x, y) = 2xy + 5x^2y + y^3$

a.  $g(-2, 2)$

b.  $g(-1, -1)$

5.  $g(x, y) = \frac{4x+y}{x-y}$

a.  $g(3, -1)$

b.  $g(2, 2)$

6.  $f(x, y) = \frac{2x-y}{x^2+y}$

a.  $f(6, 2)$

b.  $f(3, -9)$

7.  $g(x, y) = \frac{8x^2y}{\sqrt{2x+y}}$

a.  $g(1, -4)$

b.  $g(-2, 6)$

8.  $f(x, y) = \frac{5x^2+y^3}{\sqrt{4x+y^2}}$

a.  $f(-1, 3)$

b.  $f(3, 2)$

9.  $g(x, y) = 3xe^{x+y}$

a.  $g(2, 1)$

b.  $g(-1, 0)$

10.  $g(x, y) = ye^{4x} + 2xy$

a.  $g(1, 5)$

b.  $g(-1, 3)$

11.  $f(x, y) = x \ln xy + y \ln x$

a.  $f(1, e)$

b.  $f(e^2, 1)$

12.  $f(x, y) = 2x^3y + \ln y$

a.  $f(-2, e)$

b.  $f(3, 1)$

13.  $A(P, r, t) = Pe^{rt}$

a.  $A(1000, 0.08, 4)$

b.  $A(500, 0.06, 5)$

14.  $A(P, r, t) = P\left(1 + \frac{r}{4}\right)^{4t}$

a.  $A(1500, 0.08, 6)$

b.  $A(800, 0.06, 10)$

15.  $S(l, w, h) = 2lw + 2lh + 2wh$

a.  $S(18, 15, 9)$

b.  $S(14, 9, 11)$

In Exercises 16–19, draw a three-dimensional coordinate system, and graph and label the given points.

16.  $A(0, 0, 3)$ ;  $B(2, -1, 0)$ ;  $C(4, 2, 1)$ ;  $D(3, -2, -2)$

17.  $A(0, 1, 0)$ ;  $B(3, 0, -4)$ ;  $C(1, 1, -3)$ ;  $D(-2, 3, 0)$

18.  $A(-3, 0, 2)$ ;  $B(0, 0, 2)$ ;  $C(2, -2, 2)$ ;  $D(0, -2, 2)$

19.  $A(-3, -2, 1)$ ;  $B(4, 0, -1)$ ;  $C(0, 0, 4)$ ;  $D(-1, 4, -1)$

In Exercises 20–25, draw a three-dimensional coordinate system, and graph the given planes.

20.  $x = 0$

21.  $y = 0$

22.  $z = 0$

23.  $x = 3$

24.  $y = 2$

25.  $z = 4$

### APPLICATIONS

- 26. Stock yield:** The yield of a stock is given by the function  $Y(d, p) = \frac{d}{p}$ , where  $d$  is the dividend per share of stock and  $p$  is the price per share. Find the yield of a stock that sells for \$5.88 if the dividend is \$1.00.
- 27. Intelligence quotient:** The intelligence quotient (IQ) of a person is determined by  $f(M, C) = 100 \cdot \frac{M}{C}$ , where  $M$  is the mental age (determined by tests) and  $C$  is the actual or chronological age. Find the IQ of a child who is 13 years old and has a mental age of 15.4 years. (Round to the nearest integer.)
- 28. Cobb-Douglas production:** The number of units of a product that are manufactured by a company is given by  $f(L, K) = 300L^{0.4}K^{0.6}$ , where  $L$  is the units of labor and  $K$  is the units of capital.
- How many units of a product will be manufactured by utilizing 30 units of labor and 24 units of capital? (Round to the nearest unit.)
  - How many units will be produced if the number of units of labor and capital are doubled? (Round to the nearest unit.)
- 29. Cost:** A company manufactures two lawn mower models, standard and self-propelled. The cost of producing each standard mower is \$80, and the cost of producing each self-propelled mower is \$140. If the fixed costs are \$5200, the total cost function is given by  $C(x, y) = 5200 + 80x + 140y$ , where  $x$  is the number of standard and  $y$  is the number of self-propelled mowers.
- Find  $C(30, 20)$ .
  - Find  $C(36, 25)$ .
- 30. Cost:** The cost function for producing two models of a product is found to be  $C(x, y) = 850 + 32x + 20y$ , where  $x$  is the number of model A and  $y$  is the number of model B. The cost for model A is \$32, the cost for model B is \$20, and the fixed costs are \$850 per week.
- Find  $C(40, 24)$ .
  - Find  $C(60, 38)$ .
- 31. Cost:** The cost of producing the standard model of a video camera is \$160. The cost of producing the deluxe model is \$220.
- If a company has weekly fixed costs of \$1360, find the cost function  $C(x, y)$ , where  $x$  is the number of standard models and  $y$  is the number of deluxe models.
  - Find  $C(15, 12)$ .
- 32. Cost:** A company makes two grades of paint, grade I, guaranteed for 5 years, and grade II, guaranteed for 10 years. A gallon of grade I costs \$3.20 to make, while a gallon of grade II costs \$3.90 to make. The weekly fixed costs are \$4500.
- Find the cost function  $C(x, y)$  for making  $x$  gallons of grade I and  $y$  gallons of grade II.
  - What is the cost of making 200 gallons of grade I and 140 gallons of grade II?

- 33. Revenue:** A grocery store sells two brands of a product, the store brand and a name brand. The manager estimates that if she sells the store brand for  $x$  dollars and the name brand for  $y$  dollars, she will be able to sell  $64 - 20x + 18y$  units of the store brand and  $52 + 16x - 22y$  units of the name brand.
- Find the revenue function  $R(x, y)$ .
  - What is the revenue if she sells the store brand for \$4.00 and the name brand for \$4.50?
- 34. Revenue:** A pharmacy sells two cold remedies, one a generic remedy and the other a name brand. The store manager has determined that he can sell  $26 - 6x + 8y$  bottles of the generic remedy and  $22 + 5x - 9y$  bottles of the name brand if the prices are  $x$  dollars per bottle and  $y$  dollars per bottle, respectively.
- Find the revenue function  $R(x, y)$ .
  - What is the revenue if the generic remedy is priced at \$6.20 per bottle and the name brand is priced at \$7.00 per bottle?

- 35. Volume and surface area:** A rectangular box has no top and one partition (see diagram).

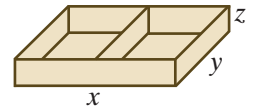

- Write a function of three variables for the number of cubic units in the volume of the box.
- Write a function of three variables for the number of square units of material needed to construct the box.

- 36. Volume and surface area:** A rectangular box has no top and two intersecting partitions (see diagram).

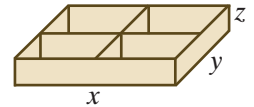

- Write a function of three variables for the number of cubic units in the volume of the box.
- Write a function of three variables for the number of square units of material needed to construct the box.

- 37. Compound interest:** A deposit of \$1000 is made into a savings account earning interest compounded quarterly. The amount  $A(r, t)$  after  $t$  years is given by

$$A(r, t) = 1000 \left( 1 + \frac{r}{4} \right)^{4t}, \text{ where } r \text{ is the interest rate in decimal form. Use this}$$

function of two variables to complete the following table.

		Number of Years ( $t$ )		
		3	5	10
Rate ( $r$ )	0.06			
	0.08			
	0.10			

- 38. Interest compounded continuously:** A deposit of \$1000 is made into a savings account earning interest compounded continuously. The amount  $A(r, t)$  after  $t$  years is given by  $A(r, t) = 1000e^{rt}$ , where  $r$  is the interest rate in decimal form. Use this function of two variables to complete the following table.

		Number of Years ( $t$ )		
		5	8	12
Rate ( $r$ )	0.080			
	0.085			
	0.090			

- c. Treat  $x$  and  $y$  as constants. In this case, the entire expression  $2ye^{xy}$  is treated as a constant.

$$\frac{\partial w}{\partial z} = 0 + 2z = 2z$$

## 8.2 EXERCISES

### PRACTICE

Find  $\frac{\partial f}{\partial x}$  and  $\frac{\partial f}{\partial y}$  for each of the functions in Exercises 1–28.

1.  $f(x, y) = 4x + 7y - 10$
2.  $f(x, y) = 11x - 19y + 2$
3.  $f(x, y) = 2x^2 + 5y^2$
4.  $f(x, y) = 5x^3 - 6y^4$
5.  $f(x, y) = x^2y + 4xy^3 + 6$
6.  $f(x, y) = x^3 - 90x^2y^3 - 9$
7.  $f(x, y) = y\sqrt{25 + x^2}$
8.  $f(x, y) = x^3\sqrt{y^2 + 5}$
9.  $f(x, y) = \sqrt{49 - x^2 - y^2}$
10.  $f(x, y) = \sqrt{16 + 2x^2 + y^2}$
11.  $f(x, y) = 4e^{x-y}$
12.  $f(x, y) = 7e^{xy}$
13.  $f(x, y) = x \ln y$
14.  $f(x, y) = \ln(x^2 + y^2)$
15.  $f(x, y) = \ln(x^2 + 3xy)$
16.  $f(x, y) = \frac{y}{\ln x}$
17.  $f(x, y) = \frac{2x^2}{y^2 + 1}$
18.  $f(x, y) = \frac{x^2 + 3}{5y - 9}$
19.  $f(x, y) = \frac{x^2}{xy + 3}$
20.  $f(x, y) = \frac{x + y}{4x - y}$
21.  $f(x, y) = x^3e^y + ye^{x^2}$
22.  $f(x, y) = xe^{y^3} - y^2e^x$
23.  $f(x, y) = x\sqrt{xy + 2}$
24.  $f(x, y) = y\sqrt{x^2 + y^3}$
25.  $f(x, y) = x^4e^{-xy}$
26.  $f(x, y) = y^3e^{-xy}$
27.  $f(x, y) = y^5 \ln(x^2 - 5y^2)$
28.  $f(x, y) = 3x \ln(xy^4)$

In Exercises 29–32, find  $\frac{\partial S}{\partial m}$  and  $\frac{\partial S}{\partial b}$ .

29.  $S(m, b) = (2m + b - 9)^2 + (4m + b - 13)^2 + (5m + b - 18)^2$
30.  $S(m, b) = (8m + b - 17)^2 + (9m + b - 23)^2 + (10m + b - 28)^2$
31.  $S(m, b) = (6m + b - 40)^2 + (8m + b - 49)^2 + (9m + b - 55)^2 + (10m + b - 62)^2$
32.  $S(m, b) = (12m + b - 81)^2 + (13m + b - 88)^2 + (14m + b - 96)^2 + (15m + b - 101)^2$

In Exercises 33–44, find all second-order partial derivatives  $f_{xx}$ ,  $f_{yy}$ ,  $f_{xy}$ , and  $f_{yx}$ .

33.  $f(x, y) = 3xy + x^2y^3 - 19$

34.  $f(x, y) = 5x^3y - 3x^3y^2 - 13$

35.  $f(x, y) = x^4y^{\frac{2}{3}}$

36.  $f(x, y) = (xy)^{\frac{3}{4}}$

37.  $f(x, y) = xe^{2y}$

38.  $f(x, y) = \frac{e^{x^3}}{y^4}$

39.  $f(x, y) = (4x - 3y)^{\frac{5}{3}}$

40.  $f(x, y) = \sqrt{7x^3 + y^2}$

41.  $f(x, y) = \frac{3x+1}{5y+3}$

42.  $f(x, y) = \frac{6y^2 - 5}{2x + 7}$

43.  $f(x, y) = \frac{2xy}{x - y}$

44.  $f(x, y) = \frac{x - y}{xy}$

In Exercises 45–48, find  $f_x$ ,  $f_y$ , and  $f_z$ .

45.  $f(x, y, z) = xy + 2xz + 9yz$

46.  $f(x, y, z) = 3x^2y + 2xyz + 7xz^2$

47.  $f(x, y, z) = (8x^2 + 5y^2 - 2z^2)^2$

48.  $f(x, y, z) = \sqrt{x^2 + 2y^2 + 4z^2}$

In Exercises 49–52, find  $\frac{\partial F}{\partial x}$ ,  $\frac{\partial F}{\partial y}$ , and  $\frac{\partial F}{\partial \lambda}$ . (Note that  $\lambda$  is the Greek letter lambda.)

49.  $F(x, y, \lambda) = 8x + 15xy - 2y^2 + \lambda(x + y - 60)$

50.  $F(x, y, \lambda) = 3x^2 + 12y^2 + \lambda(x + 2y - 84)$

51.  $F(x, y, \lambda) = 5x^2 + 3xy - 10y^2 + \lambda(14x + 17y - 49)$

52.  $F(x, y, \lambda) = 7x^2 - 2xy + 9y^2 + \lambda(8x + 15y - 120)$

### APPLICATIONS

**53. Marginal productivity:** The number of units of a product that are manufactured by a company is given by  $f(L, K) = 80L^{\frac{2}{3}}K^{\frac{1}{3}}$ , where  $L$  is the units of labor and  $K$  is the units of capital. Find the marginal productivity of labor and the marginal productivity of capital if the company is currently utilizing 27 units of labor and 64 units of capital.

**54. Marginal productivity:** The productivity of a company is approximated by  $f(L, K) = 20L^{\frac{2}{5}}K^{\frac{3}{5}}$ , where  $L$  is the units of labor and  $K$  is the units of capital. Find the marginal productivity of labor and the marginal productivity of capital if the company is currently utilizing 32 units of labor and 32 units of capital.

**55. Marginal cost:** A company manufactures two products, product A and product B. The cost of producing  $x$  units of A and  $y$  units of B is  $C(x, y) = 3000 + 7x + 5.8y + 0.03x^2 - xy + 0.02y^2$ .

- Find the marginal cost with respect to  $x$ .
- Find the marginal cost with respect to  $y$ .

- 56. Marginal profit:** The profit from the sale of two products is given by the function  $P(x, y) = 88x + 54y - 0.02x^2 - 0.015y^2 - 68$ , where  $x$  is the number of units of product A sold, and  $y$  is the number of units of product B sold.
- Find the marginal profit with respect to  $x$ .
  - Find the marginal profit with respect to  $y$ .
- 57. Marginal profit:** A company produces two models of a product. The cost function is given by  $C(x, y) = x^2 - 2xy + 2y^2 + 4x + 3y + 8$  and the revenue function is given by  $R(x, y) = 20x + 15y$ , where  $x$  is the number of units of model A and  $y$  is the number of units of model B produced and sold.
- Find the profit function.
  - Find  $P_x(20, 14)$  and  $P_y(20, 14)$  and interpret the results.
- 58. Marginal profit:** A firm produces and sells  $x$  units of product A and  $y$  units of product B. Its revenue function is given by  $R(x, y) = 80x + 100y$  and its cost function is given by  $C(x, y) = x^2 + 1.5y^2 - xy + 1500$ . Find  $P_x(50, 25)$  and  $P_y(50, 25)$  and interpret the results.
- 59. Marginal profit:** A marketing manager of a department store has determined that revenue is related to the number of units of television advertising  $x$  and the number of units of newspaper advertising  $y$  by the function  $R(x, y) = 500(20x + 5y + 20xy - x^2)$ . Each unit of television advertising costs \$5000 and each unit of newspaper advertising costs \$2500.
- Find the marginal profit with respect to  $x$ .
  - Find the marginal profit with respect to  $y$ .
- 60. Marginal profit:** A firm manufactures and sells two models of electric mowers. The standard model of the mower sells for \$300, and the self-propelled model of the mower sells for \$400. The total cost function is  $C(x, y) = 90,000 + 0.05x^2 + 0.1y^2 + 0.125xy$ , where  $x$  is the number of standard models and  $y$  is the number of self-propelled models.
- Find the marginal profit with respect to  $x$ .
  - Find the marginal profit with respect to  $y$ .

## 8.3 EXERCISES

 PRACTICE

For each of the Exercises 1–24, find all local maxima, local minima, and saddle points.

1.  $f(x, y) = x^2 + y^2 - 6x + 2y - 4$

2.  $f(x, y) = x^2 + 2y^2 + 8x - 4y + 2$

3.  $f(x, y) = x^2 - y^2 - 10x + 2y + 9$

4.  $f(x, y) = 12x + 8y - x^2 - y^2 - 7$

5.  $f(x, y) = 5x + 8y - x^2 - y^2 + 11$

6.  $f(x, y) = y^2 - x^2 + 6x - y - 10$

7.  $f(x, y) = x^2 + xy - y^2 - 5y - 8$

8.  $f(x, y) = x^2 - 2xy + 4y^2 - 6y + 3$

9.  $f(x, y) = 2x^2 - 3xy + 3y^2 + 5x - 13$

10.  $f(x, y) = 10x - 2x^2 + 2xy - 3y^2 + 5$

11.  $f(x, y) = x^2 - xy + y^2 - 2x - 2y + 1$

12.  $f(x, y) = 3x^2 - 2xy + y^2 - 16x + 4y + 14$

13.  $f(x, y) = -x^2 + xy - y^2 + 4x - 5y + 6$

14.  $f(x, y) = x^2 + 3y^2 + 5xy + 4x - 3y + 15$

15.  $f(x, y) = x^3 + y^2 - 3x - 6y + 11$

16.  $f(x, y) = x^3 - 3x^2 - 2y^2 - 9x + 8y + 7$

17.  $f(x, y) = x^2 - y^3 + 9y^2 - 4x - 15y - 14$

18.  $f(x, y) = 2x^2 + y^3 - 3y^2 - 12x - 24y + 21$

19.  $f(x, y) = x^3 - 3x^2y + 12y$

20.  $f(x, y) = 9x - xy^2 + 2y^3$

21.  $f(x, y) = 2x^2 - x^2y + y^2$

22.  $f(x, y) = x^2 - 2xy^2 + 4y^2$

23.  $f(x, y) = xy + \frac{2}{x} + \frac{4}{y}$

24.  $f(x, y) = xy + \frac{9}{x} + \frac{3}{y}$

 APPLICATIONS

25. **Profit:** An automobile agency sells two models of a car. The annual profit is estimated by  $P(x, y) = -0.1x^2 - 0.2y^2 + 6x + 10y - 160$  in thousands of dollars. Find the number of each model that should be sold to maximize profit.

26. **Sales:** The owner of a small business advertises in the newspaper and on radio. He has found that the number of units that he sells is approximated by  $N(x, y) = -0.5x^2 - y^2 + 8x + 12y + 240$ , where  $x$  (in thousands of dollars) is the amount spent on newspaper advertising and  $y$  (in thousands of dollars) is the amount spent on radio advertising. How much should he spend on each to maximize the number of units sold?
27. **Profit:** A firm produces two kinds of magazine racks, one selling for \$50 and the other for \$45. The total cost of producing  $x$  of the \$50 racks and  $y$  of the \$45 racks is given by  $C(x, y) = 0.15x^2 + 0.1y^2 - 10x - 3y + 4760$  dollars. Find the number of each kind that should be produced and sold to maximize the profit.
28. **Profit:** A company makes two types of work gloves, leather and cloth. The leather gloves sell for \$5.80 and the cloth gloves for \$1.60. The total cost function is  $C(x, y) = 0.25x^2 + 0.03y^2 + 1.3x + 0.4y + 14$  in thousands of dollars, where  $x$  (in thousand pairs) is the number of leather gloves and  $y$  (in thousand pairs) is the number of cloth gloves. How many gloves of each type should be produced and sold to maximize profits?
29. **Revenue:** A department store sells two types of T-shirts, adult and youth. The store manager has determined that he can sell  $23 - 6x + 8y$  adult T-shirts and  $26 + 5x - 9y$  youth T-shirts if the price is  $x$  dollars for the adult and  $y$  dollars for the youth. Find the price of each that will yield maximum revenue.
30. **Revenue:** A grocery store sells two brands of a product, a name brand and a store brand. The manager estimates that if she sells the name brand for  $x$  dollars per unit and the store brand for  $y$  dollars per unit, she will be able to sell  $62 - 20x + 18y$  units of the name brand and  $53 + 16x - 22y$  units of the store brand. Find the price of each that will yield maximum revenue.
31. **Construction:** A rectangular box is to be constructed without a top and with one partition. The volume of the box must be  $162 \text{ in.}^3$  Find the dimensions that will minimize the material required to construct the box.

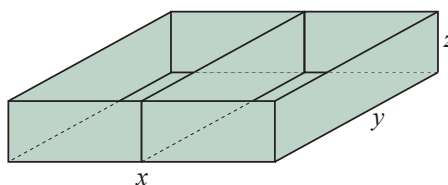

32. **Packaging:** The Postal Service has a limit of 108 inches on the combined length and girth of a rectangular package to be sent by parcel post. Length is the measurement for the longest side and girth is the distance around the package perpendicular to the length. Find the dimensions of the package of maximum volume that can be sent.

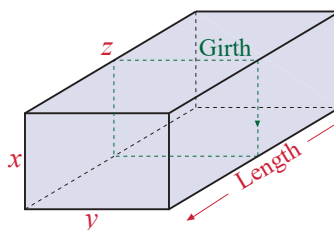

## 8.4 EXERCISES

 PRACTICE

In Exercises 1–8, use the method of Lagrange multipliers to find the minimum value of  $f$  subject to the given constraint.

1.  $f(x, y) = x^2 + y^2$ , subject to  $x + y - 4 = 0$
2.  $f(x, y) = 4x^2 + 3y^2$ , subject to  $x + y - 7 = 0$
3.  $f(x, y) = 5x^2 + 4y^2 - 2x$ , subject to  $x - y - 2 = 0$
4.  $f(x, y) = 2x^2 + y^2 - 18x$ , subject to  $3x - y - 8 = 0$
5.  $f(x, y) = 6x^2 + 5y^2 - xy$ , subject to  $2x + y = 24$
6.  $f(x, y) = 2x^2 + 3y^2 - 3xy$ , subject to  $x + y = 16$
7.  $f(x, y) = x^3 + y^3$ , subject to  $x + y = 8$
8.  $f(x, y) = x^3 - y^3$ , subject to  $x - y = 10$

In Exercises 9–16, use the method of Lagrange multipliers to find the maximum value of  $f$  subject to the given constraint.

9.  $f(x, y) = 2x^2 - 5y^2$ , subject to  $x - y = 3$
10.  $f(x, y) = 5y^2 - 8x^2$ , subject to  $x + y = 6$
11.  $f(x, y) = 8xy - 3x^2$ , subject to  $x + 2y = 14$
12.  $f(x, y) = 6x^2 - 5xy$ , subject to  $2x - y = 8$
13.  $f(x, y) = x^2 + y^2 + 4xy$ , subject to  $3x + 4y = 23$
14.  $f(x, y) = x^2 - 4y^2 + 84xy$ , subject to  $5x + 2y = 18$
15.  $f(x, y) = 15x^{0.4}y^{0.6}$ , subject to  $10x + 8y = 200$
16.  $f(x, y) = 8x^{\frac{1}{2}}y^{\frac{1}{2}}$ , subject to  $6x + 15y = 450$

In Exercises 17–20, use the method of Lagrange multipliers to find the maximum and minimum values of  $f$  subject to the given constraint.

17.  $f(x, y) = 4xy$ , subject to  $x^2 + 4y^2 = 72$
18.  $f(x, y) = 5xy$ , subject to  $9x^2 + y^2 = 162$
19.  $f(x, y) = x^3 + 4y^3$ , subject to  $x + y = 6$
20.  $f(x, y) = 3x^3 + y^3$ , subject to  $3x + y = 8$

 APPLICATIONS

- 21. Cost:** A company has a plant in Los Angeles and a plant in Oklahoma City. The firm is committed to produce a total of 40 units of a product each week. The cost function is given by  $C(x, y) = 0.3x^2 + 0.2y^2 + 20x + 7y + 200$ , where  $x$  is the number of units produced in Los Angeles and  $y$  is the number of units produced in Oklahoma City. How many units should be produced in each plant to minimize the total weekly costs?
- 22. Profit:** A department store sells two styles of a jacket, lined and unlined. During the month of January, the management expects to sell exactly 250 jackets. The profit function is given by  $P(x, y) = -0.3x^2 - 0.4y^2 - 0.3xy + 80x + 65y - 1000$ , where  $x$  is the number of lined jackets sold and  $y$  is the number of unlined jackets sold. How many of each type should be sold to maximize the profit?
- 23. Production:** The production function for a certain product is given by  $f(x, y) = 75x^{0.3}y^{0.7}$ , where  $x$  is the number of units of labor and  $y$  is the number of units of capital. Each unit of labor costs \$300, and each unit of capital costs \$200. If the company's budget allows a total of \$20,000 for labor and capital, find the maximum level of production.
- 24. Production:** The management of a company has determined that  $x$  units of labor and  $y$  units of capital are required to produce  $f(x, y) = 130x^{0.4}y^{0.6}$  units of a product. Each unit of labor costs \$450, and each unit of capital costs \$360. Find the maximum number of units that can be produced if a total of \$90,000 is available for labor and capital.
- 25. Sales:** A sales representative for a textbook publishing company estimates her monthly sales for March to be  $S(x, y) = 30x + 18y - 1.2x^2 - 0.6y^2$  in thousands of dollars, where  $x$  and  $y$  represent the number of days spent in each of the two metropolitan areas that comprise her sales territory. If she plans to work 20 days during the month, how many days should she spend in each area to maximize her sales?
- 26. Revenue:** The marketing manager of a department store has determined that revenue, in dollars, is related to the number of units of television advertising  $x$  and the number of units of newspaper advertising  $y$  by the function  $R(x, y) = 500(20x + 5y + 6xy - x^2)$ . Each unit of television advertising costs \$3000, and each unit of newspaper advertising costs \$1500. If the advertising budget is \$30,000, find the maximum revenue.
- 27. Construction:** A farmer wants to build a rectangular pen and then divide it with two interior fences. The total area enclosed is to be 2484 ft<sup>2</sup>. The exterior fence costs \$18 per foot, and the interior fence costs \$16.50 per foot. Find the dimensions of the pen that will minimize the cost of fencing.

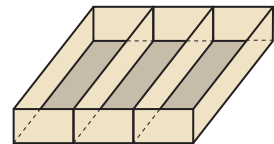

- 28. Shipping:** A container manufacturer is asked to design a closed rectangular shipping crate with a square base. The volume of the crate is 36 ft<sup>3</sup>. The material for the top costs \$1 per square foot, the material for the sides costs \$0.90 per square foot, and the material for the bottom costs \$1.40 per square foot. Find the dimensions that will minimize the total cost of building the crate.

## 8.5 EXERCISES

 PRACTICE

In Exercises 1–4, **a.** find the equation of the regression line for the given points, and **b.** draw the scatter diagram and graph the regression line.

- $(0, 3), (1, 5), (2, 7), (3, 8), (5, 9), (6, 9)$
- $(1, 10), (2, 8), (3, 7), (4, 6), (5, 5), (6, 5), (7, 4)$
- $(1, 9.6), (2, 8.7), (3, 7.7), (4, 6.1), (5, 5.0)$
- $(1, 5.2), (2, 6.4), (3, 8.1), (4, 9.2), (5, 10.6)$

In Exercises 5–10, find the equation of the regression line for the given points.

- $(10, 6.5), (20, 5.8), (30, 5.6), (40, 3.1), (50, 1.8)$
- $(1, 0.2), (2, 0.4), (3, 0.3), (4, 0.6), (5, 0.6)$
- $(1, 236), (2, 248), (3, 270), (4, 285), (5, 291)$
- $(1, 0.45), (3, 0.71), (4, 0.82), (5, 0.94)$
- $(0.6, 4.8), (0.8, 5.0), (1.0, 4.8), (1.2, 5.2), (1.4, 5.8)$
- $(3.2, 0.10), (4.1, 0.15), (4.8, 0.20), (5.1, 0.23), (6.0, 0.29)$

 APPLICATIONS

- 11. Advertising budget:** During the last 5 years, the advertising manager for a corporation has gathered the following data that shows the relationship between the advertising budget (in millions of dollars) and the total sales (in thousands of units).

<b>Advertising Budget (<math>x</math>)</b> (in millions)	\$4.5	\$6.5	\$3.5	\$3.2	\$2.6
<b>Sales (<math>y</math>)</b> (in thousands)	37	46	42	32	29

- Find the regression line for the data.
  - Estimate the sales if \$4 million is budgeted for advertising.
- 12. Price:** Records at a company for the last 5 years show the following relationship between the units sold (in thousands) and the price of a product.

<b>Price (<math>p</math>)</b>	\$8.80	\$8.00	\$7.50	\$6.90	\$6.20
<b>Quantity Sold (<math>x</math>)</b> (in thousands)	3.8	5.2	7.3	8.0	9.6

- Find the regression line for the price in terms of units.
- Estimate the price that should be charged in order to sell 10,000 units.

- 13. Construction:** The following data shows the amount spent on office building construction (in thousands) for a particular county during a six-month period.

Month	Apr	May	June	July	Aug	Sept
Amount (in thousands)	\$24	\$19	\$30	\$49	\$68	\$69

- Find the regression line for the data.
- Estimate the amount spent in October.

- 14. Revenue:** The annual revenue (in millions of dollars) for a corporation is given in the following table.

Year	1999	2000	2001	2002	2003	2004
Revenue (in millions)	\$66	\$82	\$127	\$201	\$310	\$392

- Find the line of regression for the data.
- Estimate the revenue for 2005.

- 15. Livestock futures:** The price of livestock futures is the estimated market price of livestock on the delivery date (end of the indicated month). The cattle futures (in cents per pound) for the months February through July are as follows.

Month	Feb	Mar	Apr	May	June	July
Price (¢ per pound)	79.10	76.02	71.80	71.45	71.45	72.50

- Find the line of regression for the data.
- Estimate the price for August.

- 16. Tourism:** The total number of foreign tourists visiting the United States, as reported by the U.S. Travel and Tourism Administration, is shown in the following table.

Year ( $x$ )	2000	2001	2002	2003	2004
Tourists ( $y$ ) (in millions)	25.7	26.3	29.7	34.2	38.3

- Find the regression line for the data.
- Estimate the number of foreign tourists that visited the United States in 2005.

- 17. Sales:** The foreign sales of an automobile manufacturer are given in the following table.

Year	2000	2001	2002	2003	2004	2005
Units Sold (in millions)	2.01	2.02	2.10	2.05	2.14	2.30

- Find the line of regression for the data.
- Estimate the foreign sales for 2006.

## 8.6 EXERCISES

 PRACTICE

In Exercises 1–10, evaluate the given double integral.

1.  $\int_0^1 \int_1^2 (x+1) dy dx$
2.  $\int_0^2 \int_1^3 (4-x) dy dx$
3.  $\int_{-1}^2 \int_1^4 (3x+2y) dy dx$
4.  $\int_{-2}^2 \int_3^4 (2x-y) dy dx$
5.  $\int_1^2 \int_2^3 \frac{2y}{x} dy dx$
6.  $\int_1^3 \int_{-1}^2 \frac{3y}{2x} dy dx$
7.  $\int_1^3 \int_{-2}^2 (x^2 + 3y^2 - 1) dx dy$
8.  $\int_2^3 \int_{-1}^1 (2x^2 + y^2 - x) dx dy$
9.  $\int_0^2 \int_0^1 e^{x+y} dx dy$
10.  $\int_0^1 \int_{-1}^2 ye^{xy} dx dy$

In Exercises 11–16, evaluate the double integral on the given rectangular region.

11.  $\iint_R (x - y^2) dA$      $R: 0 \leq x \leq 2$  and  $0 \leq y \leq 1$
12.  $\iint_R (xy + x) dA$      $R: 0 \leq x \leq 3$  and  $0 \leq y \leq 3$
13.  $\iint_R y\sqrt{x+1} dA$      $R: 0 \leq x \leq 3$  and  $1 \leq y \leq 5$
14.  $\iint_R x^2\sqrt{3+y} dA$      $R: -1 \leq x \leq 4$  and  $1 \leq y \leq 6$
15.  $\iint_R e^{x+2y} dA$      $R: 0 \leq x \leq 3$  and  $0 \leq y \leq 4$
16.  $\iint_R e^{2x+y} dA$      $R: 0 \leq x \leq 2$  and  $0 \leq y \leq 1$

In Exercises 17–24, evaluate the double integral.

17.  $\int_0^2 \int_0^{3x} xy^2 dy dx$
18.  $\int_0^1 \int_{2x}^{x^2} x^2 y^2 dy dx$
19.  $\int_1^4 \int_0^{x^2} \sqrt{\frac{y}{x}} dy dx$
20.  $\int_1^4 \int_x^{x^2} \sqrt{\frac{x}{y}} dy dx$
21.  $\int_1^3 \int_1^{e^y} \frac{y}{x} dx dy$
22.  $\int_0^2 \int_0^y e^{y^2} dx dy$
23.  $\int_0^4 \int_0^y \sqrt{9+y^2} dx dy$
24.  $\int_0^2 \int_0^{4-y^2} y\sqrt{x} dx dy$

In Exercises 25–34, evaluate the double integral on the given region.

25.  $\iint_R 2xy dA$      $R: 0 \leq x \leq 1$  and  $x^2 \leq y \leq \sqrt{x}$
26.  $\iint_R 3xy^2 dA$      $R: 0 \leq x \leq 1$  and  $x^3 \leq y \leq \sqrt[3]{x}$
27.  $\iint_R (x^2 - y) dA$      $R: 1 \leq x \leq 2$  and  $x \leq y \leq x^2$

$$28. \iint_R (3 - 2x - 2y) dA \quad R: 0 \leq x \leq 1 \text{ and } 0 \leq y \leq (2 - x)$$

$$29. \iint_R e^y dA \quad R: 0 \leq x \leq 2 \text{ and } x \leq y \leq 3x$$

$$30. \iint_R e^y dA \quad R: 0 \leq x \leq 1 \text{ and } 0 \leq y \leq 2x$$

$$31. \iint_R (x + y) dA$$

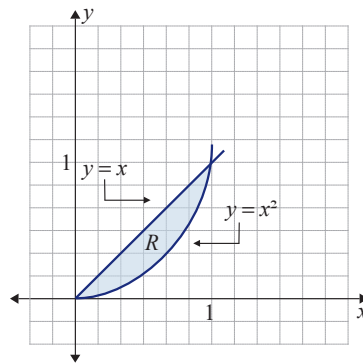

$$32. \iint_R (2xy + x) dA$$

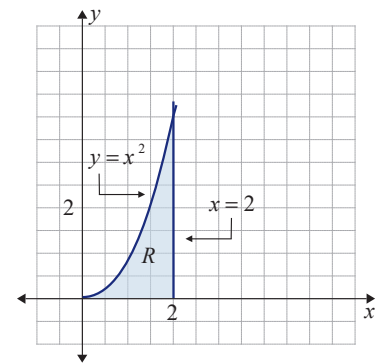

$$33. \iint_R (3 - 2xy) dA$$

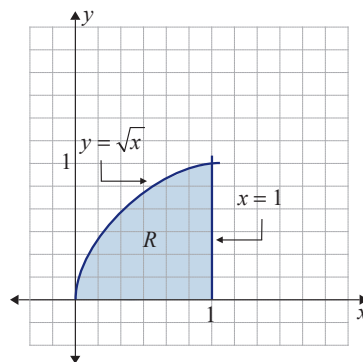

$$34. \iint_R \sqrt{4 - x^2} dA$$

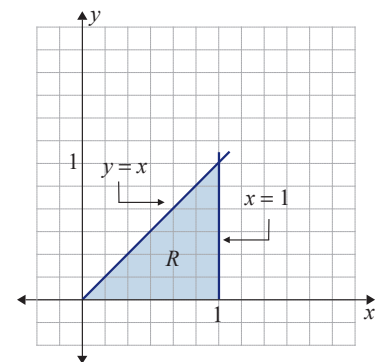

35. Find the volume of the solid bounded above by the graph of  $f(x, y) = 8 - x^2 - y^2$  and below by the rectangle  $R: -1 \leq x \leq 2$  and  $0 \leq y \leq 2$ .

36. Find the volume of the solid bounded above by the graph of  $f(x, y) = 2 + x^2 + y^2$  and below by the rectangle  $R: 0 \leq x \leq 1$  and  $0 \leq y \leq 3$ .

37. Find the volume of the solid bounded above by the graph of  $f(x, y) = 8 - 4x - 2y$  and below by the triangle with vertices  $(0, 0, 0)$ ,  $(2, 0, 0)$ , and  $(0, 4, 0)$ .

38. Find the volume of the solid bounded above by the graph of  $f(x, y) = 3 + x + 2y$  and below by the triangle with vertices  $(0, 0, 0)$ ,  $(0, 2, 0)$ , and  $(2, 0, 0)$ .

39. Find the volume of the solid bounded above by the graph of  $f(x, y) = 2xy$  and below by the region bounded by  $y = \sqrt{x}$ ,  $y = 0$ , and  $x = 1$ .

40. Find the volume of the solid bounded above by the graph of  $f(x, y) = 4x^2y$  and below by the region bounded by  $y = x^2$ ,  $y = 0$ , and  $x = 1$ .

## 9.1 EXERCISES

 PRACTICE

In Exercises 1–12, find the exact value of each of the given trigonometric functions.

1.  $\cos \frac{\pi}{3}$

2.  $\tan \frac{\pi}{4}$

3.  $\sin \frac{3\pi}{4}$

4.  $\cos \frac{5\pi}{6}$

5.  $\tan \frac{13\pi}{6}$

6.  $\sin \frac{8\pi}{3}$

7.  $\cot \frac{\pi}{2}$

8.  $\sec \frac{9\pi}{4}$

9.  $\csc \left( -\frac{\pi}{6} \right)$

10.  $\tan \left( -\frac{2\pi}{3} \right)$

11.  $\cos \left( -\frac{5\pi}{4} \right)$

12.  $\sin \left( -\frac{\pi}{2} \right)$

In Exercises 13–20, use a calculator to find the value of each of the given trigonometric functions. Round your answer to four decimal places.

13.  $\tan(64.3^\circ)$

14.  $\cos(102.6^\circ)$

15.  $\sin(246.1^\circ)$

16.  $\sin(-53.2^\circ)$

17.  $\cos(2.31)$

18.  $\tan(0.891)$

19.  $\cos(-1.32)$

20.  $\sin(-3.69)$

In Exercises 21–24, sketch the graph of each of the given functions over the interval  $[-\pi, 2\pi]$ .

21.  $y = 3 \cos x$

22.  $y = 4 \sin x$

23.  $y = \sin(2x)$

24.  $y = \cos(4x)$

In Exercises 25–28, verify each trigonometric identity.

25.  $\csc^2 \theta - 1 = \cot^2 \theta$

26.  $\sin(2\theta) = 2 \sin \theta \cos \theta$  (**Hint:**  $2\theta = \theta + \theta$ )

27.  $1 - \frac{\cos \theta}{\sec \theta} = \sin^2 \theta$

28.  $\frac{\cos \theta}{\sec \theta} + \frac{\sin \theta}{\csc \theta} = 1$

In Exercises 29 and 30, find the values of the six trigonometric functions of  $\theta$ .

29.

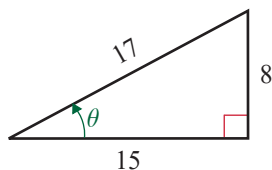

30.

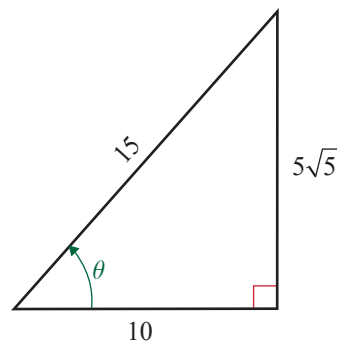

 APPLICATIONS

- 31. Aviation:** An airplane that is approaching an airport is descending at an angle of  $3.2^\circ$ . Find the decrease in altitude if the plane travels a horizontal distance of 40 miles. Round your answer to the nearest thousandth.
- 32. Safety:** In order to use a ladder safely, the angle that the ladder forms with the ground should not exceed  $70^\circ$ . If you have a ladder that is 16 ft long, what is the maximum height on the wall of a building that the ladder will safely reach? Round your answer to the nearest thousandth.
- 33. Height of a tree:** A tree casts a shadow that is 17 ft long. If the sun is at  $42^\circ$  above the horizon, find the height of the tree. Round your answer to the nearest thousandth.
- 34. Sales:** A contractor sells heating and air-conditioning units. The number of units he expects to sell each month is given by  $N(t) = 28 + 12 \cos\left(\frac{\pi}{3}(t-1)\right)$ , where  $t = 1$  represents the month of January.
- Find  $N(1)$ ,  $N(4)$ ,  $N(7)$ ,  $N(10)$ , and  $N(13)$ .
  - How many units does the contractor expect to sell in September?
- 35. Predator-prey model:** A predator-prey model (see Example 4) for the relationship between a population of coyotes and a population of rabbits is given by  $C(t) = 1000 + 500 \sin\left(\frac{\pi}{3}t\right)$  for the number of coyotes and the function  $R(t) = 10,000 + 2000 \cos\left(\frac{2\pi}{9}t\right)$  for the number of rabbits.
- Find the period  $T_1$  of  $C(t)$ .
  - Find the period  $T_2$  of  $R(t)$ .

b. Find the derivative of  $N(t)$ , and evaluate the derivative for  $t = 4$ .

$$\begin{aligned} N'(t) &= 200 \left[ -\sin\left(\frac{\pi}{6}t\right) \right] \cdot \frac{\pi}{6} \\ &= -\frac{100\pi}{3} \sin\left(\frac{\pi}{6}t\right) \\ N'(4) &= -\frac{100\pi}{3} \sin\left(\frac{\pi}{6} \cdot 4\right) \\ &= -\frac{100\pi}{3} \sin\left(\frac{2\pi}{3}\right) \\ &= -\frac{100\pi}{3} \left(\frac{\sqrt{3}}{2}\right) \approx -91 \end{aligned}$$

At the end of August, the population is decreasing by about 91 geese per month.

## 9.2 EXERCISES

### PRACTICE

In Exercises 1–28, find the derivative for each function.

1.  $f(x) = 6 \cos(4x)$

2.  $f(x) = 2 \tan(3x)$

3.  $f(x) = -3 \sin^3 x$

4.  $f(x) = 5 \cos^4 x$

5.  $y = \ln x + \tan(2x)$

6.  $y = e^x - \sin(5x)$

7.  $y = x^2 \cos(8x)$

8.  $y = 2x^3 \tan(6x)$

9.  $f(x) = \sin x \cos x$

10.  $f(x) = e^x \cos x$

11.  $y = \frac{\sin x}{x}$

12.  $y = \frac{\tan(2x)}{x}$

13.  $y = \tan(e^{3x})$

14.  $y = \sin(\ln x)$

15.  $f(x) = \sqrt{\cos(5x)}$

16.  $f(x) = \sqrt{\sin(4x)}$

17.  $y = \sec(4x)$

18.  $y = \cot \frac{1}{x}$

19.  $y = \tan^2 x$

20.  $y = \sec^2 x$

21.  $y = \sin^2 x + \cos^2 x$

22.  $y = \sec^2 x - \tan^2 x$

23.  $y = 3e^{\cos x}$

24.  $y = -6e^{\sin x}$

25.  $f(x) = \ln(\sin x)$

26.  $f(x) = \ln(\tan x)$

27.  $y = \frac{\sin x}{1 + \cos x}$

28.  $y = \frac{1 + \sin x}{\cos x}$

In Exercises 29–34, find  $\frac{\partial f}{\partial x}$  and  $\frac{\partial f}{\partial y}$  for each function.

29.  $f(x, y) = 4x + \sin(xy)$

30.  $f(x, y) = 3 \cos(xy) + x^2 y$

31.  $f(x, y) = e^{xy} + y \sin x$

32.  $f(x, y) = \cos(xy) + x \ln y$

33.  $f(x, y) = 5x^3 \cos(3x + y)$

34.  $f(x, y) = e^{-x} \sin(x + y)$

In Exercises 35–37, verify each of the formulas.

35.  $\frac{d}{dx}[\cot x] = -\csc^2 x$

36.  $\frac{d}{dx}[\sec x] = \sec x \tan x$

37.  $\frac{d}{dx}[\csc x] = -\csc x \cot x$

38. Find the equation for the line tangent to the graph of  $y = 3 \cos\left(\frac{\pi}{2}x\right)$  at the point where  $x = 4$ .

39. Find the equation for the line tangent to the graph of  $y = 2 \sin\left(\frac{\pi}{3}x\right)$  at the point where  $x = 2$ .

### APPLICATIONS

40. **Air quality:** On a typical summer day in southern California, the level of pollutants in the air can be estimated by  $L(t) = 45.5 - 10.5 \cos(0.39t)$  PSI (Pollutant Standards Index), where  $t$  is the number of hours after 6:00 a.m. and  $1 \leq t \leq 12$ . Round your answers to the nearest thousandth.

- Find the level of pollutants at 2:00 p.m.
- Find the rate of change in the level of pollutants at noon.

41. **Marginal revenue:** The Mammoth Firewood Company cuts and sells firewood in a mountain resort. The number of cords of wood sold each month is estimated by  $N(t) = 100 - 60 \sin\left(\frac{\pi}{6}t\right)$ , where  $t$  is the time in months ( $t = 1$  corresponds to January). Firewood sells for \$140 per cord.

- Find the revenue for May.
- Find the marginal revenue for September.
- Interpret the results in part b.

42. **Population:** The fox population in a midwestern state is estimated by

$$P(t) = 2400 + 400 \sin\left(\frac{\pi}{18}t\right), \text{ where } t \text{ is in months.}$$

- Find the number of foxes when  $t = 15$ .
- Find the rate of change in the fox population when  $t = 24$ .
- Interpret the result in part b.

## Solution

The total estimated revenue is the area under the curve as shown in the figure. This area is the value of the following definite integral.

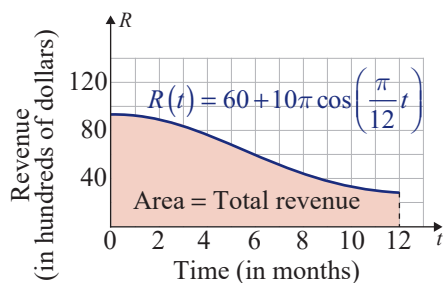

$$\begin{aligned} \int_0^{12} \left[ 60 + 10\pi \cos\left(\frac{\pi}{12}t\right) \right] dt &= 60t + 10\pi \cdot \frac{12}{\pi} \cdot \sin\left(\frac{\pi}{12}t\right) \Bigg|_0^{12} \\ &= [60(12) + 120 \sin(\pi)] - 0 \\ &= 720 \end{aligned}$$

The total estimated revenue from the ski section for one year is \$72,000.

## 9.3 EXERCISES

 PRACTICE

In Exercises 1–30, evaluate the given integral.

1.  $\int \cos(4x) dx$

2.  $\int \sin\left(\frac{1}{3}x\right) dx$

3.  $\int \sec^2(4x) dx$

4.  $\int \tan(\pi x) dx$

5.  $\int \tan(7x+1) dx$

6.  $\int \sec^2(2x+5) dx$

7.  $\int x \sin(x^2) dx$

8.  $\int x^2 \cos(x^3) dx$

9.  $\int_0^{\frac{\pi}{3}} \sin(2x) dx$

10.  $\int_{\frac{\pi}{6}}^{\frac{\pi}{3}} \cos(3x) dx$

11.  $\int_{\frac{\pi}{2}}^{\frac{\pi}{4}} (\cos x + \sin x) dx$

12.  $\int_0^{\frac{\pi}{4}} 2 \sin(\pi - x) dx$

13.  $\int_0^{\frac{\pi}{6}} \cos x \sin x dx$

14.  $\int_0^{\frac{\pi}{4}} \sec^2 x \tan x dx$

15.  $\int e^x \cos(e^x) dx$

16.  $\int e^x \sec^2(e^x) dx$

17.  $\int (\sin x) e^{\cos x} dx$

18.  $\int (\cos x) e^{\sin x} dx$

19.  $\int \frac{\tan \sqrt{x}}{\sqrt{x}} dx$

20.  $\int \frac{\sin \sqrt{x}}{\sqrt{x}} dx$

21.  $\int \frac{\sin(\ln x)}{x} dx$

22.  $\int \frac{\cos(\ln x)}{x} dx$

23.  $\int_0^{\frac{\pi}{6}} \frac{\cos x}{1 + \sin x} dx$

24.  $\int_{\frac{\pi}{4}}^{\frac{\pi}{3}} \frac{\sin(2x)}{1 - \cos(2x)} dx$

$$25. \int_{\frac{\pi}{3}}^{\frac{\pi}{2}} \frac{\sin(3x)}{(1 - \cos(3x))^2} dx \qquad 26. \int_0^{\frac{\pi}{2}} \sqrt{1 + \sin x} \cos x dx$$

$$27. \int \cot x dx \text{ (Hint: } \cot x = \frac{\cos x}{\sin x} \text{)}$$

$$28. \int \tan^2 x dx \text{ (Hint: } \tan^2 x = \sec^2 x - 1 \text{)}$$

$$29. \int \sin^2 x dx \text{ (Hint: } \sin^2 x = \frac{1}{2}(1 - \cos(2x)) \text{)}$$

$$30. \int \cos^2 x dx \text{ (Hint: } \cos^2 x = \frac{1}{2}(1 + \cos(2x)) \text{)}$$

In Exercises 31–34, integrate by parts.

$$31. \int x \cos(2x) dx$$

$$32. \int x \sin(5x) dx$$

$$33. \int x \sec^2 x dx$$

$$34. \int 3x \sec^2(2x) dx$$

35. Find the area of the region bounded by the  $x$ -axis and  $y = 3 \sin \frac{x}{2}$  on the interval  $[0, \pi]$ .

36. Find the area of the region bounded by the  $x$ -axis and  $y = 5 \cos \frac{x}{3}$  on the interval  $\left[0, \frac{\pi}{2}\right]$ .

37. Find the area of the region bounded by  $y = 2 \cos x$  and  $y = \sin(2x)$  on the interval  $\left[0, \frac{\pi}{4}\right]$ .

38. Find the area of the region bounded by  $y = \sin x$  and  $y = \tan x$  on the interval  $\left[\frac{\pi}{4}, \frac{\pi}{3}\right]$ .

39. Find the volume of the solid generated when the region bounded by the graph of  $y = 2 \sin x$ ,  $x = 0$ , and  $x = \pi$  is rotated about the  $x$ -axis. (See Section 7.6.)

### APPLICATIONS

40. **Profit:** Wes operates a boat-rental concession at a fishing resort from mid-April to mid-September. His marginal profit is approximately  $P'(t) = \frac{200\pi}{3} \sin\left(\frac{\pi}{12}(t+4)\right)$  dollars per week, where  $t$  is the number of weeks after mid-April and  $0 \leq t \leq 20$ . Find the weekly profit function  $P$ , if  $P(0) = \$1300$ .

41. **Average population:** The population of a farming community during harvest season is estimated by  $P(t) = 2600 + 180 \sin\left(\frac{\pi}{12}t\right)$ , where  $t$  is the number of weeks after the start of harvest and  $0 \leq t \leq 12$ . Find the average weekly population of the community from  $t = 4$  to  $t = 8$ . (See Section 6.4.)

## 9.4 EXERCISES

 PRACTICE

In Exercises 1–4, find the value in degrees without using a calculator.

1.  $\sin^{-1}\left(\frac{\sqrt{3}}{2}\right)$

2.  $\cos^{-1}\left(-\frac{1}{2}\right)$

3.  $\tan^{-1}(-\sqrt{3})$

4.  $\sin^{-1}\left(\frac{1}{\sqrt{2}}\right)$

In Exercises 5–8, find the value in radians without using a calculator.

5.  $\cos^{-1}\left(-\frac{1}{\sqrt{2}}\right)$

6.  $\tan^{-1} 0$

7.  $\tan^{-1}\left(\frac{1}{\sqrt{3}}\right)$

8.  $\sin^{-1}\left(\frac{1}{2}\right)$

In Exercises 9–14, use a calculator to find the value in radians. Round your answer to two decimal places.

9.  $\sin^{-1}(-0.5913)$

10.  $\tan^{-1}(1.5763)$

11.  $\cos^{-1}(0.8136)$

12.  $\cos^{-1}(-0.3876)$

13.  $\tan^{-1}(-0.8752)$

14.  $\sin^{-1}(0.6971)$

In Exercises 15–24, find the derivative of each function.

15.  $y = \cos^{-1}(x^2)$

16.  $y = \tan^{-1}\left(\frac{1}{x}\right)$

17.  $f(x) = \sin^{-1}(\sqrt{x})$

18.  $f(x) = \cos^{-1}(\ln|x|)$

19.  $f(x) = \tan^{-1}(e^x)$

20.  $f(x) = \sin^{-1}(e^{2x})$

21.  $y = \cos^{-1}(2x+1)$

22.  $y = \tan^{-1}(\sqrt{2x})$

23.  $y = \sin^{-1}(1-3x)$

24.  $y = \cos^{-1}\left(\frac{1}{x^2}\right)$

In Exercises 25–34, evaluate each integral.

25.  $\int \frac{1}{1+4x^2} dx$

26.  $\int \frac{1}{\sqrt{1-16x^2}} dx$

27.  $\int \frac{e^x}{1+e^{2x}} dx$

28.  $\int \frac{x}{\sqrt{1-0.25x^4}} dx$

29.  $\int \frac{1}{\sqrt{x}(\sqrt{1-x})} dx$  (Hint: Let  $u = \sqrt{x}$ .)

$$30. \int \frac{1}{x \left[ 1 + (\ln(2x))^2 \right]} dx \quad (\text{Hint: Let } u = \ln(2x).)$$

$$31. \int_0^{\frac{1}{4}} \frac{1}{\sqrt{1-4x^2}} dx$$

$$32. \int_0^{\frac{\sqrt{2}}{2}} \frac{x}{\sqrt{1-x^4}} dx$$

$$33. \int_{\frac{\pi}{2}}^{\pi} \frac{\cos x}{1 + \sin^2 x} dx \quad (\text{Hint: Let } u = \sin x.)$$

$$34. \int_1^3 \frac{4}{\sqrt{x}(1+x)} dx \quad (\text{Hint: Let } u = \sqrt{x}.)$$

35. Find the volume of the solid of revolution generated when the region bounded by  $y = \frac{1}{\sqrt{1+x^2}}$ ,  $x = 0$ , and  $x = 1$  is rotated about the  $x$ -axis.

### APPLICATIONS

36. **Worker efficiency:** A manufacturer estimates the time it takes for a new employee to produce the  $x^{\text{th}}$  item is given by  $T(x) = 90 - 25 \tan^{-1}(0.2x)$  minutes.
- Find  $T'(6)$ .
  - Interpret the result in part a.
37. **Election campaign:** A candidate for the board of trustees for a college plans to do an intensive door-to-door campaign. She predicts that the number of votes gained from this activity will be  $N(x) = 900 \sin^{-1}(0.007x)$ , where  $x$  is the percent of the homes in the district visited by her workers and  $0 < x \leq 100$ .
- Find  $N'(60)$ .
  - Interpret the result in part a.
38. **Drug acceptance:** The percent of doctors who are prescribing a new drug is changing at a rate given by  $P'(t) = \frac{16.5}{1 + 0.09t^2}$  percent per month, where  $t$  is the number of months after the drug is made available. What percent of the doctors are prescribing the drug at the end of 6 months?

Oresme used sums of areas of rectangles to represent the series in two different ways, as shown in Figures 2 and 3.

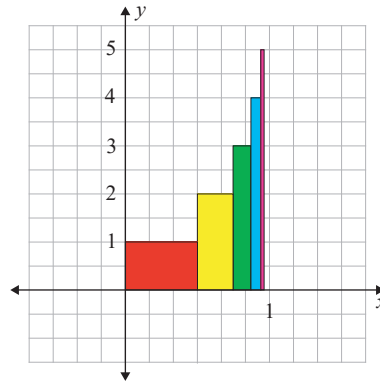

FIGURE 2

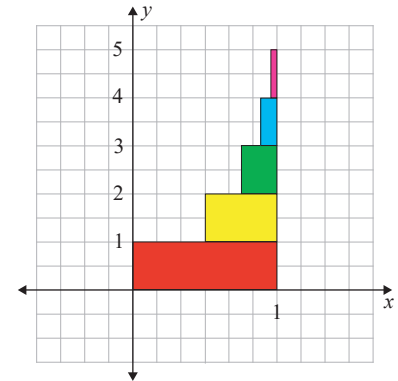

FIGURE 3

In Figure 2, the bases of the rectangles are the following decreasing powers of 2:  $2^{-1}, 2^{-2}, 2^{-3}, \dots$ . The heights of the rectangles are the integers 1, 2, 3, .... Thus, the total area of all the rectangles is the sum  $1 \cdot \frac{1}{2} + 2 \cdot \frac{1}{4} + 3 \cdot \frac{1}{8} + \dots$ . Notice that the area of each rectangle corresponds to a term in the original series whose sum we need to find.

In Figure 3, the same total area is decomposed into rectangles of height 1 with bases that are the following decreasing powers of 2:  $2^0, 2^{-1}, 2^{-2}, 2^{-3}, \dots$ . Thus, the total area of all these rectangles is the sum  $1 + \frac{1}{2} + \frac{1}{4} + \frac{1}{8} + \dots$ . We recognize this sum as a geometric series with  $a = 1$  and  $r = \frac{1}{2}$ . Therefore, the total area is  $\frac{a}{1-r} = \frac{1}{1-\frac{1}{2}} = \frac{1}{\frac{1}{2}} = 2$ .

## 10.1 EXERCISES

### 💡 PRACTICE

In Exercises 1–6, write the first five terms of the sequence.

1.  $a_n = \frac{(-1)^n}{n}$

2.  $a_n = \frac{3}{e^n}$

3.  $a_n = \sqrt{2n+1}$

4.  $a_n = \frac{\ln n}{\ln(n+1)}$

5.  $a_n = \frac{n^2-1}{n+1}$

6.  $a_n = \frac{n^3+1}{n+1}$

In Exercises 7–12, find a formula for the  $n^{\text{th}}$  term of the sequence, if one exists, assuming a domain starting with  $n = 1$ .

7.  $\{3, -5, 7, -9, \dots\}$

8.  $\{11, 14, 17, 20, \dots\}$

9.  $\{5, 10, 15, 20, 25, \dots\}$

10.  $\{3, -2, 1, 0, 1, -2, \dots\}$

11.  $\{2, 5, 10, 17, 26, 37, 50, \dots\}$

12.  $\{3, 8, 15, 24, 35, 48, \dots\}$

In Exercises 13–16, determine the limit  $\lim_{n \rightarrow \infty} f(n)$ .

13.  $f(n) = 1 + \frac{3}{n}$

14.  $f(n) = \frac{(-1)^n}{2}$

15.  $f(n) = \frac{17n}{18n+1}$

16.  $f(n) = \sum_{i=0}^n \frac{1}{2^i}$

In Exercises 17–22, compute the sums.

17.  $\sum_{n=1}^5 (2n-1)^2$

18.  $\sum_{n=1}^5 n(-1)^n$

19.  $\sum_{n=4}^8 (n-1)$

20.  $\sum_{i=1}^4 (3^i - 2^i)$

21.  $\sum_{i=1}^3 \frac{i^3 - 1}{i^2 + i + 1}$

22.  $\sum_{i=1}^5 \frac{i+1}{i^2 + i}$

In Exercises 23–30, find the sum if the series converges.

23.  $\sum_{j=0}^{\infty} \left(\frac{\sqrt{2}}{2}\right)^j$

24.  $\sum_{n=0}^{\infty} \frac{2n}{n+2}$

25.  $\sum_{n=0}^{\infty} (-1)^{n+1} \left(\frac{1}{2}\right)^n$

26.  $\sum_{n=0}^{\infty} \left(\frac{e}{\pi}\right)^n$

27.  $\sum_{j=0}^{\infty} \frac{2j+1}{10j+1}$

28.  $1 + e^{-1} + e^{-2} + e^{-3} + \dots$

29.  $4 - 0.4 + 0.04 - 0.004 + \dots$

30.  $1 - 2 + 3 - 4 + 5 - 6 + \dots$

### APPLICATIONS

31. A tennis ball drops from a height of one foot above the ground. It falls and bounces back to  $\frac{1}{4}$  of its previous position. It continues to fall and bounce back in the same proportion until it comes to rest. (Take downward as a negative direction.)
- What is the net distance traveled by the ball?
  - What is the total (absolute value) of the distance traveled by the ball?
32. The XYZ Corporation, a small business, generates \$300,000 in annual operating cash, which it spends on equipment, supplies, and services. Assume half of this amount is then spent by the recipients of XYZ's business in the general economy on similar items with similar results. Assuming this pattern of economic growth continues, how much total revenue is spent in the economy from the original \$300,000?

33. A patient takes a 10-milligram tablet of a blood pressure drug every day, and 30% of each day's dose is still in the patient's system after 24 hours. After a few weeks, how much of the medicine is in the patient's body at any one time (to the nearest milligram)?
34. A patient in a VA hospital takes a 5-milligram tablet of an experimental antidepressant drug daily. After 24 hours, a certain percentage of the previous day's dose is retained in the patient's system. After several weeks of taking the new medicine, the patient has 7.5 milligrams of the antidepressant in his body. What percentage of a daily dose is retained for the next day (to the nearest percent)?
35. Suppose 50 million taxpayers received a \$1000 one-time tax cut, of which each person spent 90% and saved 10%. The proportion that each person spent is called the marginal propensity to consume and the proportion saved is the marginal propensity to save. Assume the money spent was then spent by others in the same proportion, and so on. How much total spending was generated by the tax cut?

 **WRITING & THINKING**

36. a. Write out the first 10 partial sums to evaluate the expression  $\sum_{n=1}^{10} (2n-1)$ .
- b. Use the results of part a. to determine a shortcut to evaluate  $\sum_{n=1}^{100} (2n-1)$ .
37. Determine a rational number equal to the number (repeating decimal) given.
- a.  $\frac{4}{10} + \frac{3}{100} + \frac{4}{1000} + \frac{3}{10,000} + \dots = 0.4343\dots$
- b.  $\sum_{j=0}^{\infty} \frac{5}{10^{2j}}$
38. Define a function  $f(x) = 1 + x + x^2 + x^3 + \dots = \sum_{j=0}^{\infty} x^j$ . For each  $x$  in the interval  $(-1, 1)$ , the function is defined since the series converges for each  $x$ .
- a. Determine a series for  $f'(x)$ . **Hint:** Differentiate term by term.
- b. Define  $G(x)$  by  $G(x) = \frac{1}{1-x}$ . Determine  $G'(x)$ .
- c. Determine  $f'(a)$  and  $G'(a)$  for  $a = 0.25, -0.25, -0.5$ , and  $0.5$ . Discuss or explain your answers in a short essay or paragraph.
39. Use long division of polynomials to confirm that

$$\frac{1}{1-r} = 1 + r + r^2 + r^3 + \dots + r^n + \dots$$

40. Multiply  $(1-r)(1+r+r^2+r^3+\dots+r^n+\dots)$  to confirm the result of Exercise 39.

## 10.2 EXERCISES

 PRACTICE

1. Find the linear approximation to  $y = e^x + \ln x$  near  $x = 1$ .

In Exercises 2–9, find the Taylor polynomial of degree  $k$  approximating the given function near  $x = 0$ . Using a graphing calculator, graph the given function and the Taylor approximation in the same window.

2.  $y = \frac{1}{\sqrt{1+x}}$ ,  $k = 3$

3.  $y = \cos x$ ,  $k = 6$

4.  $y = \sqrt[3]{x+2}$ ,  $k = 2$

5.  $y = \sqrt{x+4}$ ,  $k = 3$

6.  $y = x \ln(x+1)$ ,  $k = 3$

7.  $y = \ln(x+1)$ ,  $k = 3$

8.  $y = xe^x$ ,  $k = 3$

9.  $y = e^{x+1}$ ,  $k = 3$

In Exercises 10–17, find the Taylor polynomial of degree  $k$  near  $x = a$ .

10.  $y = \sin x$ ,  $a = \pi$ ,  $k = 5$

11.  $y = e^x$ ,  $a = 1$ ,  $k = 4$

12.  $y = e^{3x}$ ,  $a = 1$ ,  $k = 4$

13.  $y = \cos x$ ,  $a = \pi$ ,  $k = 6$

14.  $y = x^{\frac{1}{3}}$ ,  $a = 1$ ,  $k = 4$

15.  $y = \sqrt{x}$ ,  $a = 1$ ,  $k = 4$

16.  $y = \frac{x}{1+x}$ ,  $a = 0$ ,  $k = 5$

17.  $y = \frac{1}{1-x}$ ,  $a = 0.5$ ,  $k = 4$

18. Use the Taylor polynomial of degree 6 for  $y = \cos x$ , centered at  $x = 0$ , to estimate the area under the graph of  $y = \cos x$  from  $x = 0$  to  $x = 1.5708$ .

19. Use the Taylor polynomial of degree 5 for  $y = \sin x$ , centered at  $x = 0$ , to estimate the area under the graph of  $y = \sin x$  from  $x = 0$  to  $x = 3.14159$ .

20. Construct the Taylor polynomial of degree 3, centered at  $x = 2$ , for the function  $f(x) = \sqrt{x+1}$ . Use this polynomial to estimate a value for  $\sqrt{2}$ . Compare this to the value given by a calculator.

21. Use the Taylor polynomial of degree 3 for  $f(x) = \sqrt{x+1}$ , centered at  $x = 0$ , to estimate a value for  $\sqrt{2}$ . Compare this to the value given by a calculator.

22. Use the Taylor polynomial of degree 3, centered at  $x = 1$ , for  $f(x) = \sqrt[4]{x}$  to estimate the value of  $\sqrt[4]{0.5}$ . Compare your value with the value given by a calculator.

23. Use the Taylor polynomial of degree 3, centered at  $x = 0$ , for  $f(x) = \sqrt[4]{x+1}$  to estimate the value of  $\sqrt[4]{0.5}$  (that is, calculate  $P_3(-0.5)$ ). Compare this with your answer to Exercise 22.

24. Choose an appropriate function  $y = f(x)$ , a suitable value of  $x = a$ , and a corresponding Taylor polynomial of degree 4 in order to estimate  $\sqrt{37}$ .

25. Use a quadratic Taylor polynomial for an appropriate function  $f(x)$  and an appropriate value of  $x = a$  in order to estimate  $\sqrt[3]{27.5}$ .
26. a. Multiply the Taylor polynomial of degree 3 for  $y = \sin x$  (centered at  $x = 0$ ) by itself.  
b. Is the result equal to the Taylor polynomial of degree 6 (centered at  $x = 0$ ) for  $y = \sin^2 x$ ?
27. Use the identity  $\cos^2 x + \sin^2 x = 1$  and the Taylor polynomial of degree 6, centered at  $x = 0$ , for  $y = \sin^2 x$  (see Exercise 26b) in order to get a polynomial representation of degree 6 for  $y = \cos^2 x$ .

**WRITING & THINKING**

28. Look up Brook Taylor and write a one-page report on his major accomplishments.
29. Determine the Taylor polynomial of degree 4, centered at  $x = 0$ , for the function  $f(x) = 3 - 2x + 4x^2 - 2x^3$ . Use your solution as a basis for a conjecture about the Taylor polynomial of a given polynomial function.
30. Differentiate the Taylor polynomial of degree 7 for  $y = \sin t$  in order to get a polynomial approximation for  $y = \cos t$  near  $t = 0$ . Compare your result with your answer to Exercise 3. Make a conjecture about derivatives of Taylor polynomial approximations to given functions.

## 10.3 EXERCISES

 PRACTICE

- Use the Taylor series for  $e^x$ , centered at  $x = 0$ , and substitution to obtain a power series for  $y = x^2e^x$ .
- Use the Taylor series for  $e^x$ , centered at  $x = 0$ , and substitution to obtain a power series for  $y = \frac{e^x - 1}{x}$ .
- Use the geometric series  $\frac{1}{1-r} = 1 + r + r^2 + r^3 + \dots + r^n + \dots$  to obtain a power series for each of the following functions.
  - $\frac{1}{1+t}$
  - $\frac{1}{1+t^2}$
  - $\frac{t}{1+t}$
  - $\frac{t}{1+t^2}$
- Find a Taylor series centered at  $x = 0$  for each of the following functions.
  - $y = e^{-x}$
  - $y = e^{-x^2}$
  - $y = e^{7x}$
  - $y = \frac{x}{e^x}$
- Find the first four derivatives of  $g(x) = \frac{1}{1-x^2}$ .
  - Use your answer to part a. to construct the Taylor polynomial of degree 4 for  $g(x)$  centered at  $x = 0$ .
  - Use the geometric series for  $g(x)$  with  $a = 1$  and  $r = x^2$  and compare results.
- In engineering, the hyperbolic sine function, abbreviated  $\sinh$ , is defined by  $\sinh t = \frac{e^t - e^{-t}}{2}$ .
  - Use the first four derivatives of  $\sinh t$  to determine the Taylor polynomial of degree 4, centered at  $t = 0$ , for  $y = \sinh t$ .
  - Combine the known Taylor series for  $e^t$  and  $e^{-t}$  and get a Taylor series centered at  $t = 0$  for  $\sinh t$ . Compare your results with your answer to part a.
- In engineering, the hyperbolic cosine function, abbreviated  $\cosh$ , is defined by  $\cosh t = \frac{e^t + e^{-t}}{2}$ .
  - Use the first four derivatives of  $\cosh t$  to determine the Taylor polynomial of degree 4, centered at  $t = 0$ , for  $y = \cosh t$ .
  - Combine the known Taylor series for  $e^t$  and  $e^{-t}$  and get a Taylor series centered at  $t = 0$  for  $\cosh t$ . Compare your results with your answer to part a.
- Find a power series representation for the function  $y = \frac{1}{\sqrt{1-t}}$  by using the binomial series. Let  $p = -\frac{1}{2}$  and replace  $x$  with  $-t$ .

9. Suppose  $f(x) = \frac{1}{1-x}$ .
- Find  $f'(x)$ .
  - Replace  $\frac{1}{1-x}$  with a power series centered at  $x=0$ , and differentiate term by term.
  - Equate your answers to parts a. and b. Express your result in the following form.

$$f'(x) = ? = \sum_{n=?}^{\infty} a_n x^n$$

10. a. Get a power series representation for  $y = \frac{1}{\sqrt{1-u^2}}$ , centered at  $u=0$ . **Hint:** In Exercise 8, replace  $t$  with  $u^2$ .
- b. Since  $\frac{d}{du} \arcsin u = \frac{1}{\sqrt{1-u^2}}$ , we can say  $\arcsin x = \int_0^x \frac{1}{\sqrt{1-u^2}} du$ . In this equation for  $\arcsin x$ , substitute the series from part a. for the integrand, integrate term by term, and get a power series representation for  $\arcsin x$ .
11. Calculate the limit  $\lim_{t \rightarrow 0} \left( \frac{\sin t}{t} \right)$  as follows: replace  $\sin t$  with its Taylor series centered at  $t=0$ , simplify the quotient, and then evaluate the limit as  $t$  approaches 0.

12. Evaluate  $\int_0^1 \frac{\sin t}{t} dt$  in two ways.
- Use a graphing calculator. (Remember to set your calculator to radian mode.)
  - Replace  $\frac{\sin t}{t}$  with a Taylor polynomial of degree 6, centered at  $t=0$ , and then integrate term by term. Compare the answers.
13. Find the functions whose Taylor series coefficients, for the series centered at  $x=0$ , are specified by the given sequences.
- $\{0, 0, 0, 1, 1, 1, 1, \dots, 1, \dots\}$
  - $\{1, 2, 3, 4, 5, \dots\}$
  - $\{1, 1, 1, 0, 1, 1, \dots, 1, \dots\}$
  - $\{1, 6, 15, 20, 15, 6, 1, 0, 0, 0, \dots\}$

14. Find the functions whose Taylor series coefficients, for the series centered at  $x=0$ , are specified by the given sequences.
- $\left\{ 0, 1, 0, \frac{-1}{3!}, 0, \frac{1}{7!}, 0, \frac{-1}{9!}, 0, \frac{1}{11!}, 0, \frac{-1}{13!}, 0, \dots \right\}$
  - $\{2, 2, 2, 2, \dots\}$
  - $\left\{ 0, 1, \frac{1}{2}, \frac{1}{3}, \frac{1}{4}, \dots \right\}$
  - $\{1, 5, 10, 10, 5, 1, 0, 0, 0, \dots\}$

15. Find all seven complex number solutions of the equation  $x^7 = 1$ .

In Exercises 16–19, find  $y = f(x)$ , a polynomial of degree 4 that is an approximate solution of the boundary value problem with the given conditions.

16.  $f'(x) = y - x + 1, \quad f(0) = 1$

17.  $f'(x) = y + 1, \quad f(0) = 1$

18.  $f'(x) = (1 + x)y, \quad f(0) = 1$

19.  $f''(x) = -f(x) + 1, \quad f(0) = 1, \quad f'(0) = 1$

### WRITING & THINKING

20. Determine a calculus relationship between the hyperbolic functions  $\sinh t$  and  $\cosh t$  and their derivatives. (See Exercises 6 and 7.)

21. A function is called *odd* if it satisfies  $f(x) = -f(-x)$  for all  $x$  in its domain. For example  $y = x^3 - x$  is odd. Make a conjecture about the Taylor series of odd functions.

22. A function is called *even* if  $f(x) = f(-x)$  for all values of  $x$  in its domain. For example  $y = x^2 + 3$  is even. Make a conjecture about the Taylor series of even functions.

23. a. Integrate  $\int_0^{\frac{1}{2}} \frac{1}{1-t} dt$  using a graphing calculator.

b. Integrate  $\int_0^{\frac{1}{2}} \frac{1}{1-t} dt$  exactly.

c. Integrate  $\int_0^{\frac{1}{2}} \frac{1}{1-t} dt$  by replacing the integrand with a Taylor series centered at  $t = 0$  and integrate term by term.

d. Rewrite your answer to part c. using summation notation and equate it to your answer to part b.

24. Replace the integral in Exercise 23 with  $\int_0^1 \frac{1}{1+t} dt$  and repeat the four steps.

25. Since  $\frac{d}{dt} \arctan t = \frac{1}{1+t^2}$ , we have  $\arctan x = \int_0^x \frac{1}{1+t^2} dt$ .

a. Substitute your answer to Exercise 3b into the integral and integrate term by term to get a power series expansion for the arctangent function (first discovered in the 14<sup>th</sup> century by the Indian mathematician Madhava of Sangamagrama).

b. The interval of convergence for a geometric series is  $(-1, 1)$ . This means the interval of convergence for the answer to part a. is also expected to be  $(-1, 1)$ . However, in this case, the interval includes the endpoint  $x = 1$ . Since the angle whose tangent is 1 is the angle  $\frac{\pi}{4}$ ,  $\arctan 1 = \frac{\pi}{4}$ . Thus  $\pi = 4 \arctan 1$ . Substitute  $x = 1$  into your power series from part a. and get a numerical representation for  $\pi$  as an infinite series (originally published by Leibniz around 1676).