

$$\text{Area of the figure} = 100 \text{ in.}^2 - 39.25 \text{ in.}^2 = 60.75 \text{ in.}^2$$

The perimeter of the figure is 45.7 in. and the area of the figure is 60.75 in.²

Now work margin exercise 6.

CALCULATOR

Entering π on a Calculator

Many calculators will have a π key (may also be accessed using SHIFT EXP or SHIFT 10^x) which can be used in calculating circumferences and areas involving π . Be aware, though, that the value of π inserted by a calculator will be rounded to a minimum of 10 decimal places. As the problems in this section were calculated using $\pi = 3.14$, you may see slight differences in the answers due to rounding. For example, a circle with radius 6 has a circumference of 37.68 ft when calculated using $\pi = 3.14$. Alternatively, to find the circumference using a calculator, press the keys

$\boxed{2}$ $\boxed{\times}$ $\boxed{\pi}$ $\boxed{\times}$ $\boxed{6}$. Then press $\boxed{=}$.

The display will read 37.699111843... (your calculator may display more or fewer digits depending on its settings). Rounding this value to two decimal places gives us 37.70 ft. Even though the two circumferences differ by 0.02, both answers are considered correct.

Margin Exercise Answers

1. a. 69.08 m b. 379.94 m² 2. a. 47.1 ft b. 176.625 ft² 3. 46.26 in. 4. 417.62 yd²
5. a. 24.28 ft b. 34.28 ft² 6. a. 27.42 cm b. 21.87 cm²

6.4 Exercises

Concept Check

Fill-in-the-Blank. Complete each sentence using information found in this section.

- The line segment from one point on a circle through the center to the point directly opposite this point is a/an _____.
- The set of all points in a plane that are equidistant from a fixed point is a/an _____.
- The line segment from the center of a circle to any point on the circle is a/an _____.
- The perimeter of a circle is called the _____.
- 3.14151926535... represents pi, which is represented by the Greek letter _____.
- $C = \pi d$ is the formula to find the _____ of a circle.

True/False. Determine whether each statement is true or false. If a statement is false, explain how it can be changed so the statement will be true. (**Note:** There may be more than one acceptable change.)

- Every radius on a circle has the same length.
- Exact answers can be achieved when substituting 3.14 in place of π .

9. The length of the diameter of a circle is half of the length of the radius.
10. The area of a circle is found by using the formula $A = \pi d$.

Practice

Calculate **a.** the circumference and **b.** the area of each circle described. Use $\pi \approx 3.14$. See Examples 1 and 2.

- | | |
|-----------------------------------|---|
| 1. A circle with radius 5 ft | 6. A circle with radius 1.5 ft |
| 2. A circle with radius 1 ft | 7. A circle with diameter 60 cm |
| 3. A circle with diameter 6.2 yd | 8. A circle with diameter 14 m |
| 4. A circle with diameter 2.4 in. | 9. A circle with radius $\frac{3}{4}$ ft |
| 5. A circle with radius 0.5 m | 10. A circle with radius $12\frac{1}{5}$ mi |

Calculate **a.** the perimeter and **b.** the area of each figure. Use $\pi \approx 3.14$. See Examples 1 through 3, 5, and 6.

11.

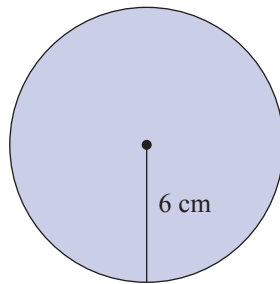

15.

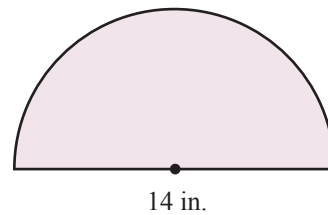

12.

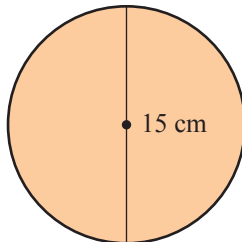

16.

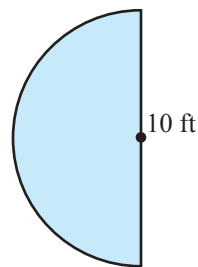

13.

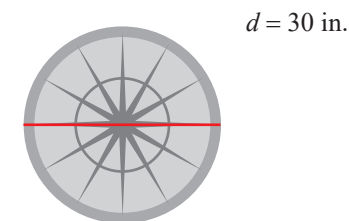

17.

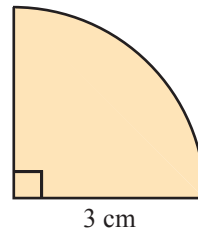

14.



18.

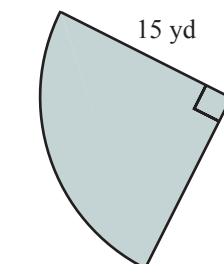

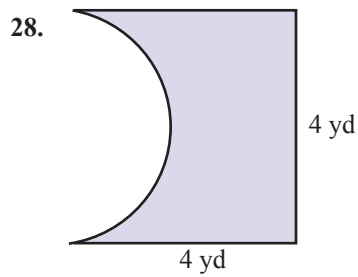
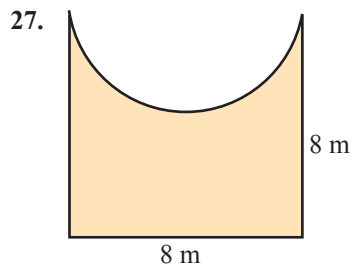
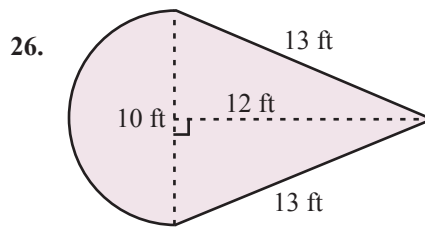
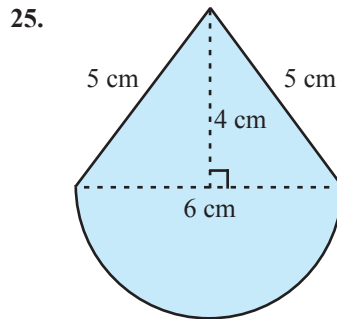
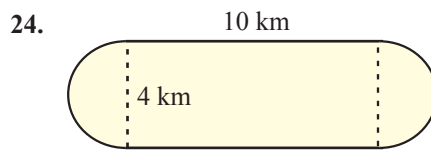
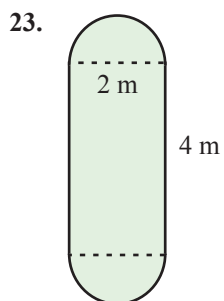
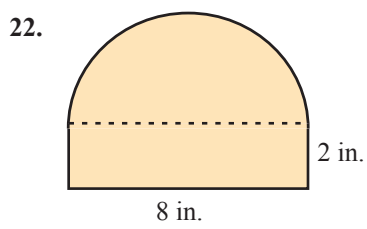
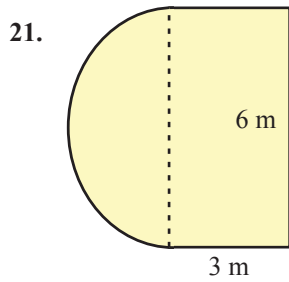
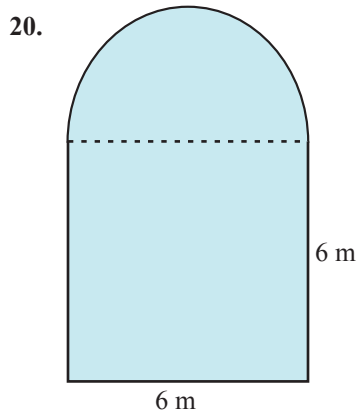
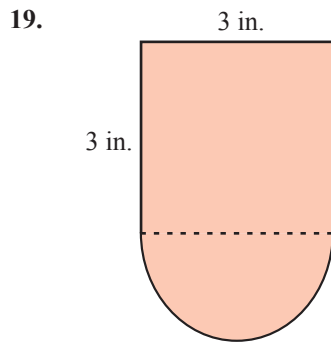

Calculate the area of the shaded portion of each figure. Use $\pi \approx 3.14$. See Example 4.

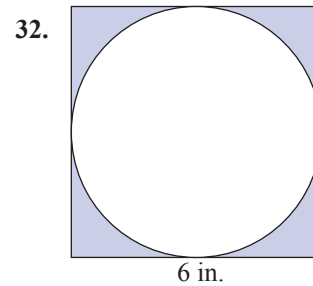
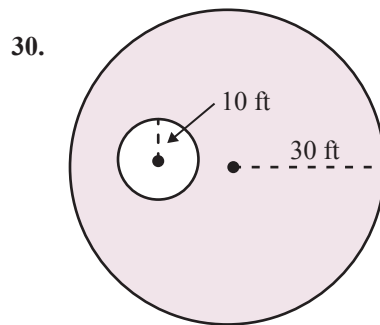
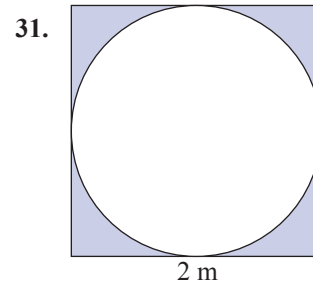
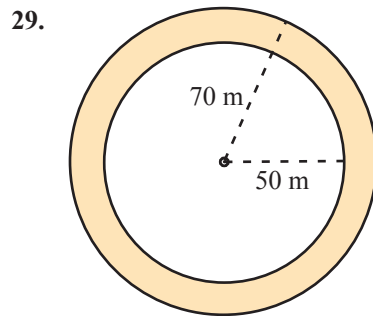

Applications

Solve. Use $\pi \approx 3.14$.

33. Papa Luigi's sells a 9-inch diameter pizza for \$8.
- Determine the area of the pizza to the nearest tenth.
 - Determine the price per square inch to the nearest cent per square inch.
34. The Numero Uno Pizza Restaurant listed the following prices for Hawaiian style pizza: 7" for \$4.75, 12" for \$11.45, and 14" for \$13.95 where the number of inches indicates the diameter of each pizza. Find the price per square inch of each size of Hawaiian pizza.

35. A door has a semicircle window above the door frame that measures 24 in. across the bottom.
- Find the perimeter of the window.
 - Find the area of the window.

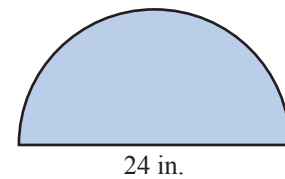

36. A large 16 in. pizza is cut into eight pieces.
- What is the perimeter of a single piece?
 - What is the area of this piece of pizza?

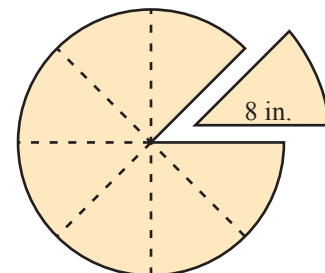

37.  Some cities use traffic circles rather than traffic lights at major intersections. A traffic circle is a circular road at the intersection, where the driver will enter, drive counterclockwise, and then leave on the desired road. If the outer diameter of the circle is 220 feet, and the road is 25 feet wide, what is the surface area of the traffic circle?

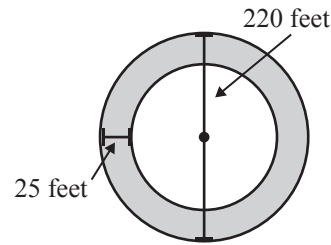

38.  An entry door is in the shape of a rectangle with the top part being a semicircle, as shown. Compute its area. (**Hint:** To find the height of the rectangular portion of the door, subtract the height (radius) of the semicircle from the total height of the door.)

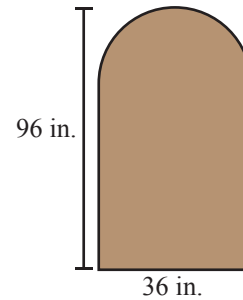

39. One common design for speaker cabinets in high quality stereo systems is the bass reflex cabinet, where there is a port (either rectangular or circular) in the front of the cabinet in addition to the speaker itself. If the front panel is 26 inches high and 18 inches wide, what will the area of the panel be if a 12-inch hole is cut out for the speaker, and a 10 inch by 4 inch rectangular port is cutout as shown?

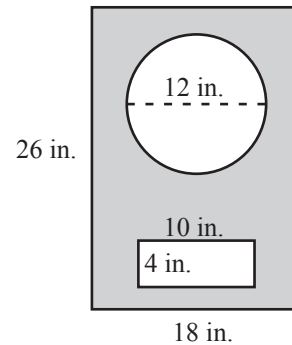

40. A 10-inch flywheel has a square opening in the center to connect it to the driving shaft. Assuming that this square hole is 1 inch on the side, what is the area of the flywheel?

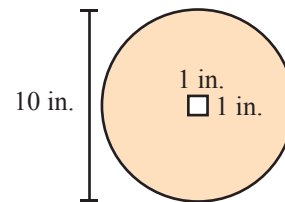

41. Brain Freeze Ice Cream is creating a new wooden sign in the shape of an ice cream cone to display their flavors of the day. The outline of the cone is shown.

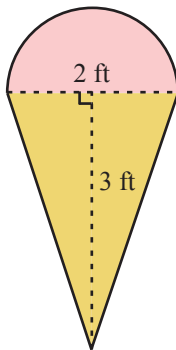

- The sign will be painted to look like an ice cream cone. What is the area of the sign to be painted? Round to the nearest hundredth.
- The sign will have a metal border to protect it from damage. How much metal border will be needed? Round to the nearest hundredth.

Solve the following word problems by finding either the circumference or the area specified. You may want to draw figures to help solve the problems. (Use $\pi \approx 3.14$.)

42. A 12-foot by 10-foot rectangular flower garden has a circular fish pond in the center. The diameter of the fish pond is 6 feet. The gardener plans to place new top soil in the garden before planting flowers. What is the area that will be covered by top soil?
43. A bicycle has tires with radius of 10 in. If John pedals this bike so that the tires rotate 1000 times fully around, how far does John ride his bike?
44. A string wraps around the center of a coffee can 6 times. If the can is 8 cm in diameter, how long is the string, to the nearest whole number?
45. A regulation Frisbee measures 10.75 inches in diameter. How much room for logos and other wording is available on the top of the Frisbee, rounded to the nearest tenth?
46. Jesse cuts three disks out of cardboard to make a snowman. If the disks are of 2-, 3-, and 4-inch radii, respectively, determine how much total cardboard was used to make the snowman.
47. Rebekah follows a nature trail once around a circular pond. If the distance across the pond (through the center) is 1500 ft, how far did Rebekah walk?
48. A Blu-ray disc has a radius of 6 cm, with a hole measuring 0.5 cm in radius cut out of the center. Determine the total amount of physical space available for recording on a Blu-ray disc, to the nearest whole number. (Assume the space available for recording extends all the way to the edges.)

Writing and Thinking

49. Explain why $2\pi r$ is equivalent to d .
50. Propose a method for calculating the area of a semicircle and justify your method.
51. Explain why answers that are calculated using π (approximately 3.14) are not precise, but are close approximations.
52. With a piece of string and a ruler, carefully measure the circumference and the diameter of several circular figures in your home. Divide each circumference by the length of the corresponding diameter. What result do you observe? Explain this result in terms of a formula.

Collaborative Learning

53. First, draw a circle with a diameter of 10 cm (radius 5 cm). Next, draw a square outside the circle so that each side of the square just touches the circle. (The square is said to be circumscribed about the circle, and the circle is said to be inscribed in the square.)
 - a. Divide the perimeter of the square by the diameter of the circle. What number did you get?
Next, on the same figure, draw an octagon (8-sided figure) that is circumscribed about the circle. Measure the perimeter of the octagon as accurately as you can.
 - b. Divide the perimeter of the octagon by the diameter of the circle. What number did you get?
 - c. Now try drawing circumscribed polygons with more sides (such as a 16-sided figure, a 32-sided figure, and so on) about the circle. Describe the numbers you think you would get by dividing the perimeters of these figures by the diameter of the circle.