

NOTE

A pair of lines cannot be both parallel and perpendicular.

Are the lines parallel? No, the slopes are not equal.
 Are the lines perpendicular? Yes, the slopes are negative reciprocals of each other.
 Thus, the lines are perpendicular.

- b. One line is in point-slope form, so we can see its slope is 9. We calculate the slope of the other line using the two points given.

$$m = \frac{22-4}{2-0} = \frac{18}{2} = 9$$

Are the lines parallel? Yes, the slopes are equal.
 Thus, the lines are parallel. (Note that we didn't need to find the equation of the second line.)

- c. Both lines are in slope-intercept form, so we can read off the slopes: $\frac{3}{4}$ and $\frac{4}{3}$.

Are the lines parallel? No, the slopes are not equal.
 Are the lines perpendicular? No, the slopes are reciprocals, not *negative* reciprocals.
 Thus, the lines are neither parallel nor perpendicular.

3.5 EXERCISES**PRACTICE**

Find the equation, in slope-intercept form, for the line parallel to the given line and passing through the indicated point. See Examples 1 and 2.

- | | |
|---|--|
| 1. $y - 4x = 7$; $(-1, 5)$ | 2. $6x + 2y = 19$; $(-6, -13)$ |
| 3. $3x + 2y = 3y - 7$; $(3, -2)$ | 4. $2 - \frac{y-3x}{3} = 5$; $(0, -2)$ |
| 5. $y - 4x = 7 - 4x$; $(23, -9)$ | 6. $2(y-1) + \frac{x+3}{5} = -7$; $(-5, 0)$ |
| 7. $6y - 4 = -3(1 - 2x)$; $(-2, -2)$ | 8. $5 - \frac{7y+5x}{2} = 1$; $(4, 1)$ |
| 9. $2(y-1) - \frac{7x+1}{3} = -3$; $(1, 10)$ | 10. $8y - 6 = -3(4 - x)$; $(11, -5)$ |

Each set of four ordered pairs defines the vertices, in counterclockwise order, of a quadrilateral. Determine if the quadrilateral is a parallelogram. See Example 3.

- | | |
|---|---|
| 11. $\{(-2, 2), (-5, -2), (2, -3), (5, 1)\}$ | 12. $\{(-1, 6), (-4, 7), (-2, 3), (1, 1)\}$ |
| 13. $\{(-3, 3), (-2, -2), (3, -1), (2, 4)\}$ | 14. $\{(-2, -3), (-3, -6), (1, -2), (2, 1)\}$ |
| 15. $\{(-6, -2), (-1, 0), (-3, 4), (-8, 2)\}$ | 16. $\{(-3, -2), (3, -3), (5, 2), (-1, 3)\}$ |
| 17. $\{(-1, -1), (5, 1), (3, 5), (-2, 3)\}$ | 18. $\{(0, 1), (6, 0), (7, 4), (1, 6)\}$ |

Determine if the two lines are parallel. See Example 6.

19. $y = 8x + 7$ and $y = -8x + 7$

20. $x - 5y = 2$ and $5x - y = 2$

21. $2x - 3y = (x - 1) - (y - x)$ and $-2y - x = 9$

22. $3 - (2y + x) = 7(x - y)$ and $\frac{5y + 1}{4} = 3 + 2x$

23. $6 = -12(x - y) + y$ and $13y = -12x + 3$

24. $\frac{2x - 3y}{3} = \frac{x - 1}{6}$ and $2y - x = 3$

25. $\frac{x - y}{2} = \frac{x + y}{3}$ and $\frac{2x + 3}{5} - 4y = 1 + 2y$

26. $5 - (4y + 3x) = 5(x - y)$ and $y + 4 = 5 + 8x$

27. $7x - 2(x + 3) = 5y - x$ and $-6x = 1 - 5y$

28. $\frac{2y + 11x}{3} = x + 1$ and $7x - 8y = 9x + 7$

29. $\frac{x - y}{5} = \frac{x + y}{3} - 1$ and $7 = -2(x - y) + 6y$

30. $2x + 5y = 14$ and the line passing through the points $(8, -5)$ and $(3, -3)$

Find the equation, in slope-intercept form, for the line perpendicular to the given line and passing through the indicated point. See Examples 4 and 5.

31. $3x + 2y = 3y - 7$; $(3, -2)$

32. $6y + 2x = 1$; $(-4, -12)$

33. $-y + 3x = 5 - y$; $(-2, 7)$

34. $x + y = 5$; origin

35. $x = \frac{1}{4}y - 3$; $(1, -1)$

36. $2(y + x) - 3(x - y) = -9$; $(2, 5)$

37. $4x + 8y = 4y - 3$; $(-2, 1)$

38. $\frac{3x - y}{4} = \frac{4x - 5}{2}$; $(8, 5)$

39. $4(y + x) - 8(x - y) = -1$; $(6, 10)$

40. $\frac{3x + 4}{3} - 3y = 1 - 4y$; $(2, -8)$

Determine if the two lines are perpendicular. See Example 6.

41. $x - 5y = 2$ and $5x - y = 2$

42. $y = 5x + 4$ and $y = -\frac{1}{5}x - 9$

43. $3x + y = 2$ and $x + 3y = 2$

44. $\frac{3x - y}{3} = x + 2$ and $x = 9$

45. $5x - 6(x + 1) = 2y - x$ and $2y - (x + y) = 4y + x$

46. $-6y + 3x = 7$ and $8x - 3(x+1) = 3y - x$
47. $-x = -\frac{2}{5}y + 2$ and $5y = 2x$
48. $\frac{7x-5y}{4} = x+2$ and $-3y-3x = 2x+4$
49. $3(4-x) = 6y+3$ and $-3y-2x = 3-8x$
50. $\frac{x-1}{2} + \frac{3y+2}{3} = -9$ and $3y-5x = x+5$
51. $1 - \frac{2y-5x}{2} = 7x+4$ and $9x-2y = 11$
52. $y - \frac{2}{3} = 4\left(x + \frac{7}{11}\right)$ and the line passing through the points $(-2, 4)$ and $(7, -14)$

Each set of four ordered pairs defines the vertices, in counterclockwise order, of a quadrilateral. Use the ideas in this section to determine if the quadrilateral is a rectangle.

53. $\{(-2, 2), (-5, -2), (2, -3), (5, 1)\}$ 54. $\{(2, -1), (-2, 1), (-3, -1), (1, -3)\}$
55. $\{(1, 2), (3, -3), (9, -1), (7, 4)\}$ 56. $\{(5, -7), (1, -13), (28, -31), (32, -25)\}$
57. $\{(-5, -1), (0, -6), (5, -1), (0, 4)\}$ 58. $\{(-3, -3), (3, -2), (1, 2), (-5, 1)\}$

 APPLICATIONS

59. A construction company is building a new suspension bridge that has support cables attached to a center tower at various heights. One cable is attached at a height of 30 feet and connects to the roadbed 50 feet from the base of the tower. If the support cables should run parallel to each other, how far from the base should the company attach a cable whose other end is connected to the tower at a height of 25 feet?

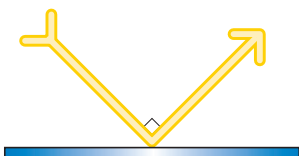
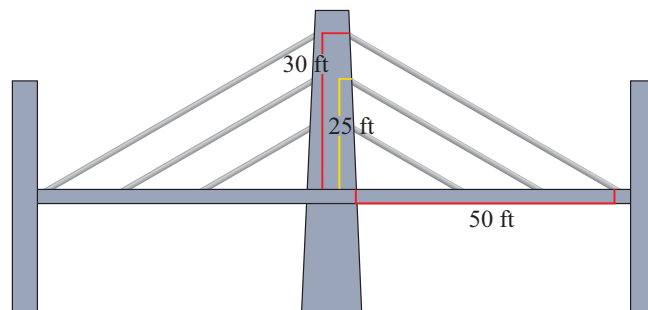

60. A light beam hits a mirror and is reflected off the mirror at a right angle. If the line formed by the original beam of light can be described by an equation of the form $y = -3.2x + b$ (for some constant b), write the form of an equation that describes the line of the reflected beam (use an arbitrary constant c in your answer).